



**OPERATION, MAINTENANCE
AND PARTS MANUAL
PNEUMATIC SPRAYING MACHINE
MODEL: **LOHE™** SERIES VI**



REED, provides this manual for the guidance of all owners, operators and servicing personnel in order to obtain the longest possible trouble-free service. It contains data, specifications, warranty, schematics, operating instructions, lubrication procedures, maintenance procedures, illustrated parts breakdown, vendor information, service bulletins, and safety rules.

Serial No.: _____

Date Delivered: _____

Customer: _____

NOTE: Additional copies of this manual (**P/N:13366A**) may be obtained through the **REED** Parts Department.

FIRST EDITION: JUNE 25,2007

STARTING SERIAL NUMBER: 4338



PNEUMATIC SPRAYING MACHINES WARRANTY

REED warrants each of its new pneumatic spraying machines to be free of defects in material and workmanship under normal use and service for a period of twelve (12) months from date of delivery to initial user or 1000 pumping hours, whichever comes first.

The **WARRANTY** is issued **ONLY** to the **INITIAL USER**. The warranty period begins when the product is delivered to the initial user or when first put into service, whichever occurs first. Said warranty is void if the machine is subject to misuse, neglect, accident or abuse.

REED'S obligation under this warranty is limited to correcting without charge, at its factory, any parts or parts thereof which shall be returned to its factory, transportation prepaid and upon **REED'S** examination proves to have been originally defective. Correction of such defects by repair or replacement shall constitute fulfillment of all obligations to the initial user. This warranty does not include labor or transportation charges unless specifically identified and authorized in writing by **REED**. Nor does the warranty apply to any unit upon which repairs or unauthorized alterations have been made.

This warranty does not apply to normal maintenance service or to normal replacement of certain machine parts which are subject to normal wear (such as feed bowls, wear plates, wear pads, liners, delivery systems, etc.). **REED** makes no warranty in respect to trade accessories or outside vendor components, such being subject to the warranties of their respective manufacturers.

THIS IS A LIMITED WARRANTY AND IS IN LIEU OF ANY OTHER WARRANTIES, EXPRESSED OR IMPLIED, INCLUDING ANY WARRANTY OF MERCHANTABILITY OR FITNESS FOR A PARTICULAR PURPOSE. In no event shall **REED** be liable for incidental, general or consequential damages, loss or any expense directly or indirectly related and resulting from use or lack of use caused by delay in delivery, parts failure, or any other causes associated with the product use. No person, firm or corporation is authorized to assume for **REED** any other liability in connection with the sale of **REED** products.



NOTICE

THIS REED LOHE MANUAL IS IMPORTANT!

This is the Operation & Maintenance Manual for your *REED* equipment. It contains information necessary for the SAFE and PROPER operation of the ***REED LOHE GUNITE MACHINE***. **ALL PERSONNEL WHO OPERATE REED EQUIPMENT MUST READ AND UNDERSTAND THIS MANUAL.** Call *REED* if you have any questions 909-287-2100 (or toll free, 888-779-7333).

This manual should be kept near the equipment at all times.

This Operators Manual also contains *REED's* written Warranty for the equipment. **PLEASE READ YOUR WARRANTY. THIS IS THE SOLE WARRANTY BY REED FOR YOUR EQUIPMENT.**

SAFETY DECALS

IT IS IMPORTANT THAT ALL SAFETY DECALS REMAIN LEGIBLE AND PROMINENTLY DISPLAYED AT ALL TIMES.

IF THE SAFETY DECALS BECOME UNREADABLE AT ANY TIME, THE MACHINE SHOULD NOT BE OPERATED UNTIL DECALS ARE CLEANED OR REPLACED. WORKER SAFETY REQUIRES PROPERLY AND PROMINENTLY DISPLAYED SAFETY DECALS.

ADDITIONAL SAFETY DECAL ARE AVAILABLE FROM REED



MODEL: LOVA PNEUMATIC SPRAYING MACHINE

GEN'L

PAGE 00

TABLE OF CONTENTS

GENERAL	GEN'L
TABLE OF CONTENTS	00
INTRODUCTION	01
PRODUCT DESCRIPTION	02
TECHNICAL SPECIFICATIONS	03
SAFETY AWARENESS AND PRECAUTIONS	04
SAFETY ALERT DECALS	06
OPERATOR QUALIFICATION	09
 OPERATION	 OPER.
PRE-OPERATION INSPECTION	00
GETTING ACQUAINTED	02
CONTROL FAMILIARIZATION	03
OPERATION INSTRUCTIONS	12
OPERATIONAL TROUBLESHOOTING TIP	15
OPERATION FOR SPRAYING OR CONVEYING WET MATERIALS	19
 MAINTENANCE	 MAINT
PREVENTATIVE MAINTENANCE	00
SCHEDULED INSPECTION	01
GENERAL MAINTENANCE AND SERVICE	02
FILTER – AIR MOTOR	02
AIR MOTOR LUBRICATOR	03
GEAR CASE	04
ADJUSTMENT	05
RISER PLATE INSTALLATION	05
FELT SEAL	07
ROCK SHEAR	07
RUBBER SEALING PAD	08
PAD ADJUSTMENT	09
 SCHEMATICS	
 PARTS	
GROUP 00 HOW TO USE PARTS MANUAL	
GROUP 10 SMALL AIR MOTOR DRIVE (8 AM) INSTALLATION	
GROUP 20 LARGE AIR MOTOR DRIVE (16 AM) INSTALLATION	
GROUP 30 BASE GEAR INSTALLATION	
GROUP 40 HOPPER AND PAD INSTALLATION	
GROUP 50 AIR INLET INSTALLATION	
GROUP 60 ACCESSORY INSTALLATION	
GROUP 70 OPTIONAL INSTALLATION	
GUNITE ACCESSORY CATALOG – TOOLS, SUPPLIES, AND PARTS	
 GUNITE ACCESSORY CATALOG – TOOLS, SUPPLIES, AND PARTS	
 VENDORS	
FIGURE 01 GAST AIR MOTOR	
FIGURE 02 WATTS AIR FILTER AND LUBRICATOR	
 SERVICE BULLETINS	
SB 001 WARRANTY PROGRAM	



MODEL: LOVA PNEUMATIC SPRAYING MACHINE

GEN'L

PAGE 01

INTRODUCTION

A major factor in the minds of the operators and maintenance personnel should be use of the machine in a **SAFE** and **PROFICIENT** manner. This can only be accomplished by having a better understanding of the operation and maintenance of the **REED GUNCRETE LOVA™ SERIES 4 DRY PROCESS PNEUMATIC SPRAYING MACHINE**.

This manual (Part Number 13365) is provided to assist in accomplishing this goal. It is considered to be a **VALUABLE** tool to our **CUSTOMERS**. It includes an Operation Section, General Maintenance Procedures, and Illustrated Parts Section. Everyone involved with the operation, maintenance and repair of the machine should be given and should take this opportunity to **READ** and thoroughly **UNDERSTAND** all sections of this manual. It is in their **BEST INTEREST** to do so.

This manual covers and is applicable to a **STANDARD EQUIPPED MACHINE** having either a **5HP-8AM** or **9HP-16AM** air motor. Depending on customer requirements and circumstances, it is possible your machine may be equipped with various options and specialized equipment. If you are aware of these items, we suggest you make a note of these which will assist you and **REED** when the need arises for ordering of parts and service. If by chance, service information is not found, it is suggested you contact the **REED SERVICE DEPARTMENT** which will forward the proper information if available.

All product descriptions, illustrations and specifications found throughout this manual were in effect at the time the manual was released for printing. It should be noted **REED RESERVES THE RIGHT TO MAKE CHANGES IN DESIGN OR TO MAKE ADDITIONS TO OR IMPROVEMENTS IN THE PRODUCT WITHOUT IMPOSING ANY OBLIGATIONS UPON ITSELF TO INSTALL THEM ON PRODUCTS PREVIOUSLY MANUFACTURED**.

NOTE

If you have not yet done so, please record the SERIAL NUMBER of your LOVA™ SERIES 4 on the cover page of this manual. Throughout this manual, reference may be made to the serial number. When talking to our SERVICE DEPARTMENT or ORDERING PARTS, use of the serial number will assist us in giving prompt and accurate response and service.



MODEL: LOVA PNEUMATIC SPRAYING MACHINE

GEN'L

PAGE 02

PRODUCT DESCRIPTION

The **REED GUNCRETE LOVA™ SERIES 4** is a dry mix pneumatic spraying machine designed specifically for the purpose of inducing granular materials into a compressed air stream. The material is then conveyed by the air through a hose line delivery system to a nozzle, where water is introduced which then mixes with the dry material and air and then is sprayed from the nozzle for the specific application. The machine is of a simple design, compact, lightweight, and is of a rugged construction to withstand the work environment surrounding the many applications of dry mix spraying.

The **LOVA™ SERIES 4** utilizes as its main power source either 5HP or 9HP air powered motor. The air supply for operations of the motor is provided by an external compressed air source. The air motor through an oil bath spur gear arrangement, is used to rotate the feed wheel or bowl. A means is provided to vary the rotating speed for the feed wheel, which in turn varies the output feed rate.

In operation, dry or damp material is placed into the hopper where it is allowed to freely fall through the wear plate openings and down into the "U" shaped pockets of the feed wheel. As the wear plate-feed wheel rotate, the pockets which are now loaded with material, pass under a molded rubber sealing pad which is set tight against the top portion of the wear plate. The rubber pad and back-up plate each contain two (2) specifically designed openings. One is used as an inlet for the compressed air and the other is used as an outlet for the air material mixture. These openings are designed to align with the "U"-shaped pockets of the wear plate. As the loaded pockets pass under the pad and line up with the openings, the compressed air which is directed to the inlet opening of the pad pushes the material from the pockets of the feed bowl and up through the pad's outlet opening where it travels through the gooseneck and on into the delivery hose and on to the nozzle. With the constant even rotation of the feed bowl, the material can be exhausted into the hose in an extremely steady flow.

Dependent on the application and material being sprayed, the **REED LOVA™ SERIES 4** can be easily field modified to interchange the feed bowl, wear plate, and hopper if so desired. The feed bowl is selected for the number of "u" shaped pockets and the size of aggregate used in the mix. Additionally, an urethane coated feed wheel can be used in place of the steel to lessen the sticking and build up of material when damp conditions are encountered. Optional hoppers, rock cones, and rock shears may also be installed.

The **LOVA™** can be equipped with a 5HP or 9HP rotary vane motor. Protection of the air motor and other related components against premature wear, the system is equipped with an air filter and lubricator. The filter is used to remove any liquids and solids from the incoming compressed air. The lubricator is used to induce a controlled oil flow into the air stream where it is atomized into an airborne oil fog which is carried to the air motor.

Controls for operation of the unit are at the machine. They include the ability to turn on and regulate the air power to the motor and feed bowl, to monitor the pressure of the systems and adjust the pad clamps.

SPECIFICATIONS

TECHNICAL DATA

	U.S.	METRIC
• Output Maximum	15 yds ³ /hr	11.5m ³ /hr
• Aggregate Size – Maximum	¾"	19mm
• Air Motor	5HP or 9 HP	3.7 or 6.6 KW
• Conveying Distance – Horizontal Max	1000 ft.	305m
• Conveying Distance – Vertical Max	300 ft.	91m
• Hose Size – I.D.	¾" to 2½"	19mm to 63mm
• Refractory Hopper Capacity	25.90 ft ³	0.734m ³

Material conveying distances shown are to be used only as a guide. Maximum attainable distances and maximum aggregate size are all dependent on mix design and material hose diameters. Maximum output and distances cannot be reached simultaneously.

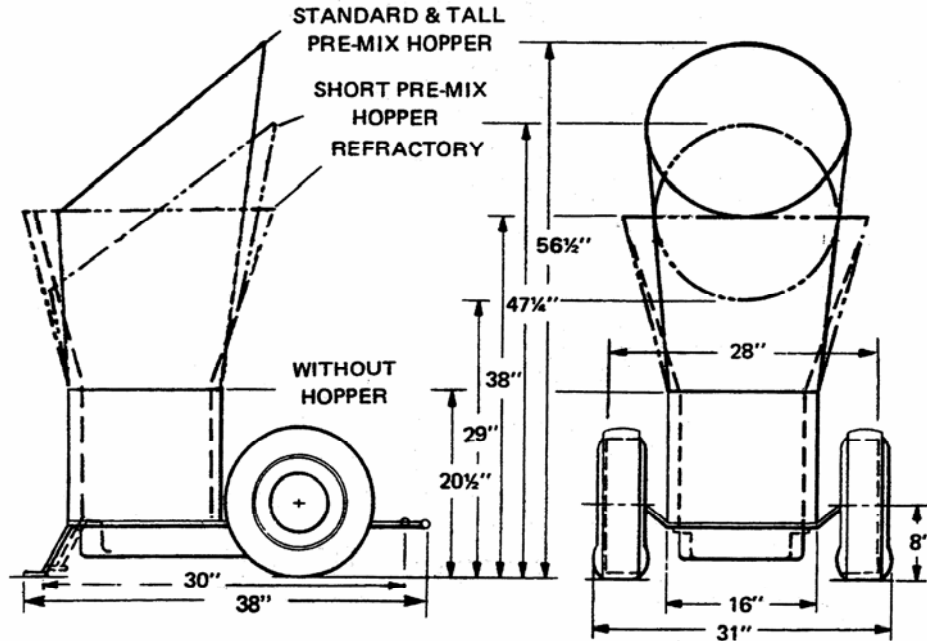

REED Production Estimates With 100 Ft (30.5m) Hose for 8 AM Air Motor. Please add 90 CFM for 16 AM Air Motor.

Hose Size	Output/hr	Max Air Required		
		@ 100 PSI (7kg/cm ²)	Aggregate	Feed Wheel
¾" (1.9cm)	2 yd ³ (1.5m ³)	150cfm (3.5m ³ /min)	1/8" (3.5mm)	30 PKT
1" (2.5cm)	4 yd ³ (3.1m ³)	250cfm (6.0m ³ /min)	¼" (7mm)	30-20 PKT
1¼" (3.2cm)	6 yd ³ (4.6m ³)	315cfm (9.0m ³ /min)	3/8" (10mm)	20-15 PKT
1½" (3.8cm)	9 yd ³ (6.9m ³)	365cfm (10.5m ³ /min)	3/8" (10mm)	15 PKT
2" (5.1cm)	12 yd ³ (9.2m ³)	600cfm (17.0m ³ /min)	½" (13mm)	STD15 PKT
2" (5.1cm)	12 yd ³ (9.2m ³)	750cfm (17.0m ³ /min)	¾" (19mm)	LA 12 or15 PKT
2½" (6.4 cm)	15 yd ³ (11.5m ³)	900cfm (25.5 ³ /min)	¾" (19mm)	LA 12 or15 PKT



MODEL: LOVA PNEUMATIC SPRAYING MACHINE

GEN'L

PAGE 04

SAFETY AWARENESS AND PRECAUTIONS

The **REED GUNCRETE LOVA™ SERIES 4** dry mix pneumatic spraying machine is only to be used for the purpose of inducing granular materials into a compressed air stream which is then conveyed through a hose line to a spraying nozzle.

All personnel assigned to operate, repair or troubleshoot the **LOVA™**, must be thoroughly familiar with this Technical Manual (P/N 13365). For the protection of yourself and others around you, it is of utmost importance that the **WORK** be done **SAFELY**. One of the best ways to accomplish this is to fully **UNDERSTAND** and **KNOW** the job you do. If there is any doubt that what you are doing is **UNSAFE**, even marginally, obtain assistance from other trained/qualified personnel.

During operation, troubleshooting, or repair, problems may arise or be encountered that seem singular, but may in fact be due to several causes. These need to be sorted out and identified before proceeding with the task at hand. The information contained in this technical manual can be used to assist in the safest and best manner of operating and repairing the **LOVA™ SERIES 4** machine.

ADVISORY LABEL LOCATION

Cautionary signal word (Warning-Caution) may appear in various locations throughout this manual. Information accented by one of these signal words must be observed to minimize the risk of personal injury to service personnel, or the possibility of improper service methods which may damage the pump or render it unsafe. Additional Notes are utilized to emphasize areas of procedural importance and provide suggestions for ease of repair. The following definitions indicate the uses of these use of these advisory labels as they appear throughout the manual:

⚠ CAUTION

Directs attention to unsafe practices, which could result in damage to equipment and possible subsequent personnel injury or death if proper precautions are not taken.

⚠ WARNING

Direct Attention to unsafe practices, which could result in personnel injury or death if proper precautions are not taken.

NOTE

An operating procedure, practice, condition, etc., which is essential to emphasize.

REVISION:

----- THINK SAFETY -----

The following points out some pretty **COMMON** conditions and situations that you might encounter at one time or another. **BE ALERTED** to these and try to **PREVENT** the inevitable. They may seem simple, but are often the **MOST OVERLOOKED**.

- Get enough sleep to be ready for the day's work. Accidents can happen when the body is on the job, but the mind is not.
- Arrive to work on time. Accidents can be caused by hurrying through procedures.
- Don't bring your personal problems to work with you. In an office setting this may be annoying to co-workers, but on a construction site it can be deadly. The workers around you depend on you for their safety.
- Use only qualified operators and nozzle men who know the machine.
- Use only qualified maintenance personnel who understand the systems.
- Dress in appropriate apparel (See Figure 1. Personal protective equipment). You should always wear these items when using Model **LOVA**™:
 - Hard hat
 - Safety glasses or goggles
 - No loose clothing
 - Gloves
 - Appropriate boots
 - Hearing protection
 - Breathing mask (Respirator)
 - Check the specific **OSHA** requirement for your jobsite
- Jewelry, athletic shoes, sandals, and shorts are examples of clothing that should **NOT** be worn when operating.

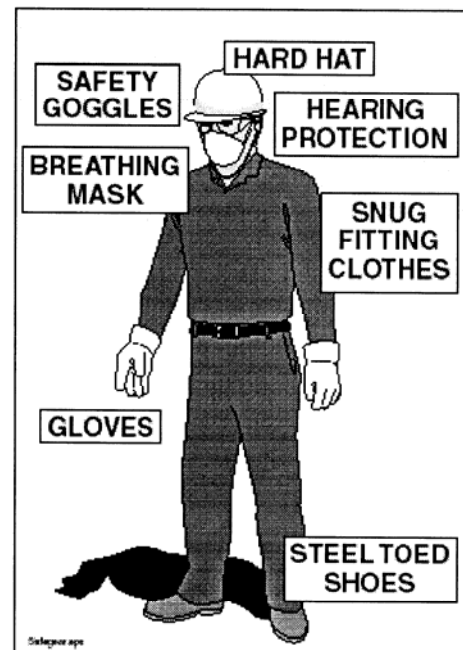

Figure 1
Personal protective equipment

----- THINK SAFETY -----

⚠ WARNING

BE SURE THAT ANY CLOTHING YOU WEAR DOES NOT HAVE STRINGS, FRINGES, OR OTHER EXTERNAL TIGHTENING MEANS THAT COULD BE CAUGHT IN MOVING PARTS (FIGURE 2. NO STRINGS ATTACHED).

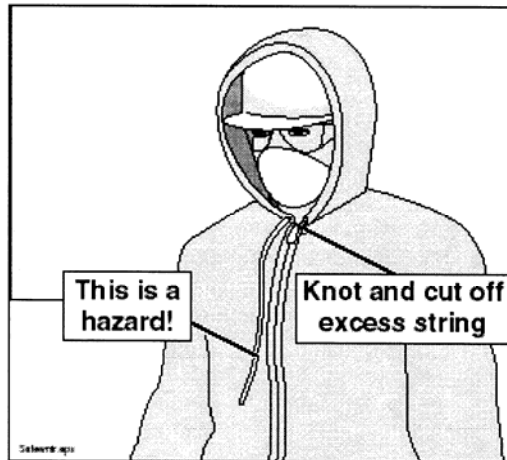

Figure 2
No strings attached

- **NEVER** go to work on a construction site or work on, around or near a piece of machinery when under the influence of drugs or alcohol. Beware of “over the counter” drugs, many of which have specific warnings about operating machinery after taking the medication (See Figure 3. Your co-workers depend upon you for their safety).



Figure 3
Your co-workers depend upon you for their safety



MODEL: LOVA PNEUMATIC SPRAYING MACHINE

GEN'L

PAGE 07

----- THINK SAFETY -----

- Keep work area clear of unauthorized personnel
- Level machine on when uneven sitting terrain and slopes.
- Do not operate machine in traffic lanes. Always place cones and barricades around the unit.
- Don't clean, lubricate, or make maintenance adjustments while unit is in operation.
- Keep safety decals and operation instructions legible.
- Do not alter or disconnect safety devices.
- Use whipcheck cables or chain safety couplings on air supply hoses.
- Use only sturdy and safe lifting devices, platforms and scaffolding for those spraying operations that are performed off the ground. All platforms should be equipped with safety rails.
- Never remove the hopper screen and put your hands into the hopper.
- Report items that need attention or require service.

⚠ WARNING

***BETTER SAFE THAN SORRY – DON'T TAKE CHANGES
THAT COULD CAUSE INJURY TO YOU AND/OR OTHERS.***

**YOUR SAFETY IS OUR UTMOST CONCERN AND YOUR
RESPONSIBILITY**



**MODEL: LOVA
PNEUMATIC SPRAYING MACHINE**

GEN'L

PAGE 08

SAFETY ALERT DECALS

D A N G E R - - - - - C A U T I O N - - - - - W A R N I N G
decals are designed for your protection. They are placed at appropriate areas on the machine to be constant reminders of the ever-present dangers. Know and adhere to the information they provide.

WARNING
ALWAYS WEAR SAFETY GLASSES
WHEN OPERATING THIS MACHINE

WARNING!

The wear pad area of this machine is extremely dangerous when the wear pad and Pad back-up assembly are removed.

It is essential that strict safety procedures be followed before performing any work in the wear pad area.

If maintenance must be performed in this area then proceed as follows:

- (1) Shut off power.
air / electric
- (2) Disconnect air feed line or electric cord.

Work in the wear pad area can now be performed safely.

Upon completion of this work, reconnect air feed line or electric cord, and restore power.



MODEL: LOVA
PNEUMATIC SPRAYING MACHINE

GEN'L

PAGE 09

SAFETY ALERT DECALS

WARNING!

The inside of the hopper of this machine has moving parts which are extremely dangerous.

It is essential that strict safety procedures be followed before any work is done in-side the hopper.

The screen on the hopper is bolted in a closed position to restrict access. If maintenance must be performed inside the hopper, proceed as follows:

- (1) Shut off power.
air / electric
- (2) Disconnect air feed line or electrical cord.
- (3) Remove bolts securing the hopper screen

Work inside the hopper may now be performed safely.

Upon completion of this work, replace the bolts and secure the hopper screen in a closed position. Reconnect air feed line or electrical cord and restore power.

CAUTION DO NOT LIFT
THIS MACHINE BY HOPPER HANDLES.
USE SLINGS UNDER MACHINE.



MODEL: LOVA
PNEUMATIC SPRAYING MACHINE

SAFETY ALERT DECALS





MODEL: LOVA PNEUMATIC SPRAYING MACHINE

GEN'L

PAGE 11

OPERATOR QUALIFICATIONS

Making the choice for an operator is a vital decision as it affects safety and productivity. The **REED MODEL CONCRETE LOVA SERIES 4** has been thoroughly inspected and tested by the **REED** Quality Control Department prior to shipment. The design of the unit incorporates several built-in safety features and also allows for an average skilled person to readily become proficient in the safe operation of the **LOVA SERIES 4**. The unit is a pressurized material pump and can be potentially **DANGEROUS** in the hands of **UNTRAINED OR CARELESS OPERATORS**.

Knowing the characteristics of the machine and function of the controls are important to **SAFE, PROPER OPERATION** and **USE**.

It is the responsibility of all users to read and comply with the following rules and information designed to promote **SAFETY** and **UNDERSTANDING** of the **LOVA SERIES 4** spraying machine.

- The first requirement for any user/operator is to obtain a thorough understanding of the operating characteristics and limitations of the machine. This should not be overlooked regardless of their prior experience with similar type equipment.
- Only **QUALIFIED TRAINED** personnel who have been authorized must be allowed to operate the **REED GUNITE LOVA SERIES 4**. A Qualified Trained Operator is one who has **READ** and **UNDERSTOOD** the instructions in this manual and is thoroughly familiar with the operating characteristics and limitations of the machine.
- Individuals who cannot **READ** and **UNDERSTAND** the signs, warnings, notices and operating instructions that are part of the job, in the language in which it is printed **MUST NOT BE ALLOWED** to operate the **LOVA SERIES 4**.
- Know and follow all cautions, warnings and operating instructions on the machine.
- Repair and adjustments must only be made by **QUALIFIED TRAINED** personnel.
- No modification is to be made to the machine without prior written consent of the **REED** Customer Service Department.
- Attach a **SIGN-OFF** sheet on the unit to enable the operator to report any damage, defects, problems or accidents to his work supervisor.
- Understand and **OBEDY** all applicable Local and Government statutes and regulations applying to safe operation and use of material pumping machines.

**AN UNKNOWING OPERATOR IS AN UNSAFE OPERATOR
AND A SORRY OPERATOR**



MODEL: LOVA PNEUMATIC SPRAYING MACHINE

OPER.

PAGE 00

PRE-OPERATION INSPECTION

The **CONDITION** of the unit prior to start-up is a very **IMPORTANT** factor as it directly affects the operator's safety as well as those around him. It should be a common practice that the operator performs a general inspection of the **REED GUNCRETE LOVA SERIES 4** before each day's operation.

The purpose of the operator's inspection is to keep the equipment in **PROPER** working condition and to **DETECT** any sign of malfunction during normal operations between scheduled maintenance checks.

DOWNTIME is **COSTLY** and can possibly be prevented by taking a few minutes prior to start-up to do a thorough walk-around inspection. This inspection must be performed each day before the unit is operated. Report any damage or faulty operation immediately. Attach a sign, if need be, at the control panel which states ----- **DO NOT OPERATE** ----- . Repair any discrepancies before use.

Some major items to be considered for your inspection include the following:

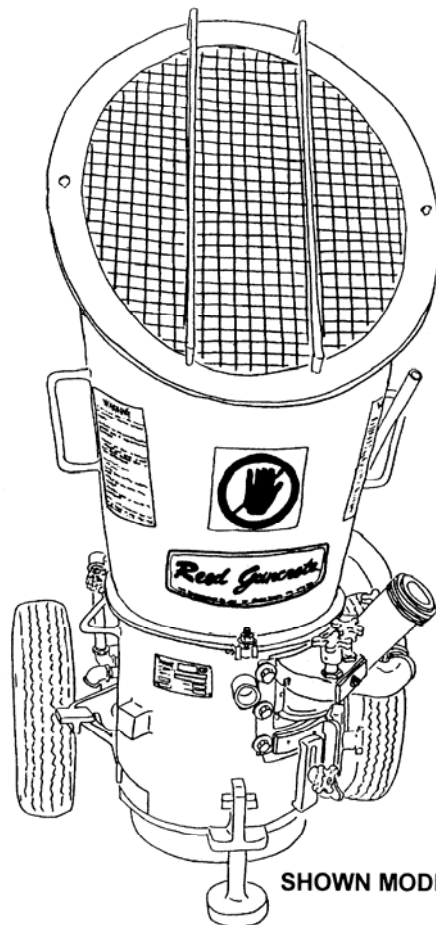

SHOWN MODEL: LOVA™ SERIES IV
8 AM STANDARD HOPPER

REVISION:



MODEL: LOVA PNEUMATIC SPRAYING MACHINE

OPER.

PAGE 01

1. OVERALL MACHINE CONDITION

- External structural damage
- Hopper screen in place
- Lock pins, chains, and retainers in place
- Wheel nuts tight
- Decals, placards, warning signs legible
- Unit is clean and free of concrete build-up
- Feed wheel wear surface is clean and flat
- Wear pad in good condition
- Gooseneck liner is in good condition
- Agitator secure, in good condition

2. AIR SYSTEM

- Loose or damaged hoses, tubing, fittings
- Air leaks
- Air valves and control levers

3. DRIVE SYSTEM

- Air motor secure
- Gear box oil at proper level
- Condition of feed wheel, seals, and wear pad
- Pad adjustment secure
- Outlet nozzle secure
- Adjustment knobs tight

⚠ CAUTION

Defective components, structural damage, missing parts or equipment malfunctions, jeopardize the SAFETY of the operator and other personnel and can cause extensive damage to the machine. A poorly MAINTAINED machine can become the greatest OPERATIONAL HAZARD you may encounter.



MODEL: LOVA PNEUMATIC SPRAYING MACHINE

OPER.

PAGE 02

GETTING ACQUAINTED (UNIT FAMILIARIZATION)

As previously indicated, it is important from a **SAFE** operational standpoint that you, the **OPERATOR**, know your machine. This means the function of each control as to what happens when it is activated, how it might interact with other functions and any limitations which might exist. A **GOOD UNDERSTANDING** of the controls and capabilities will enhance operation and assure maximum operating efficiency and **SAFETY**.

These next few pages will assist you in **GETTING ACQUAINTED** with the **MODEL LOVA™ SERIES 4**. Carefully study them.

AIR INLET AND VALVE INSTALLATION
(SEE PART SECTION GROUP 50)

HOPPER AND PAD INSTALLATION
(SEE PART SECTION GROUP 40)

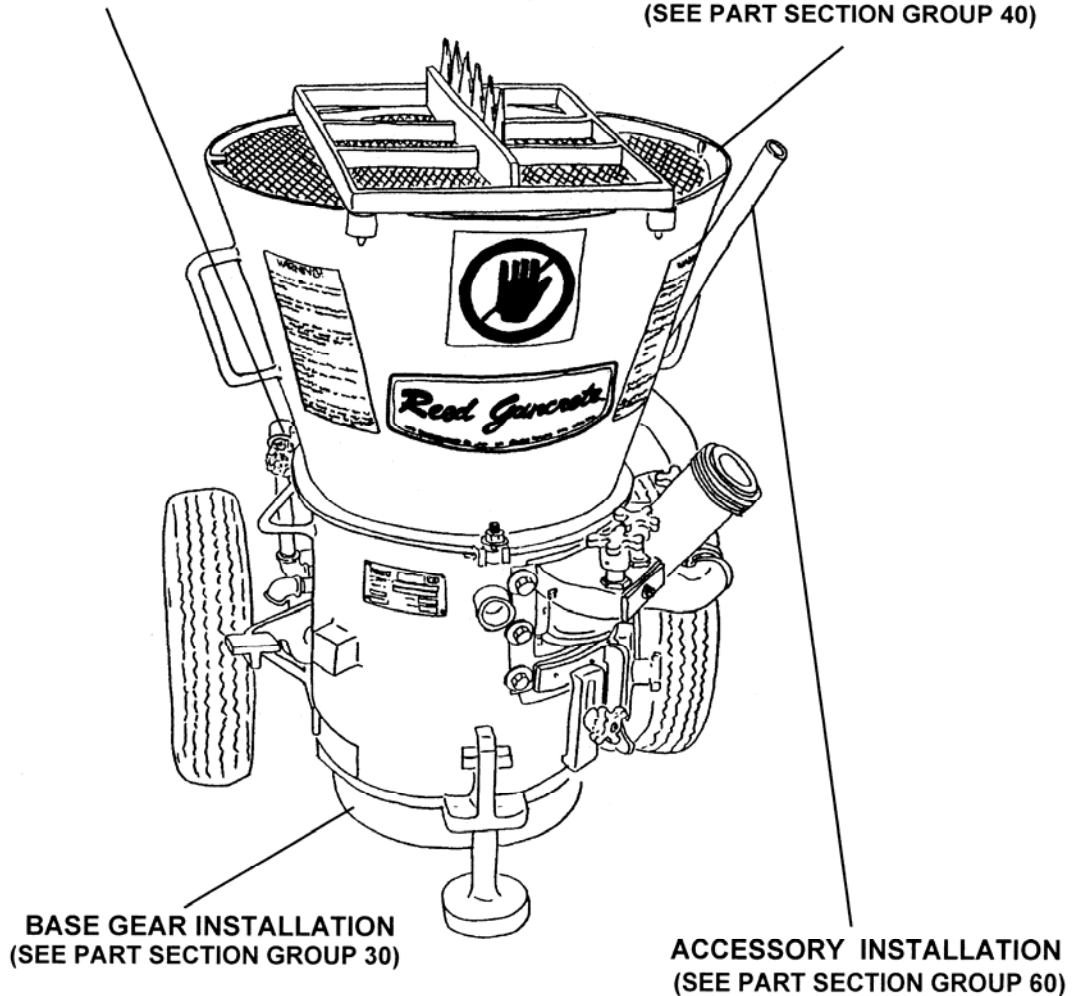

**SHOWN MODEL: LOVA™ SERIES 4
8 AM REFRACTORY HOPPER**

CONTROL AND COMPONENT FAMILIARIZATION

The **LOVA™ SERIES 4 GUN** is equipped with various controls and adjustment knobs. The controls are located at easily accessible points on the machine and each is dedicated to a specific function for the operation of the unit. These are noted below.

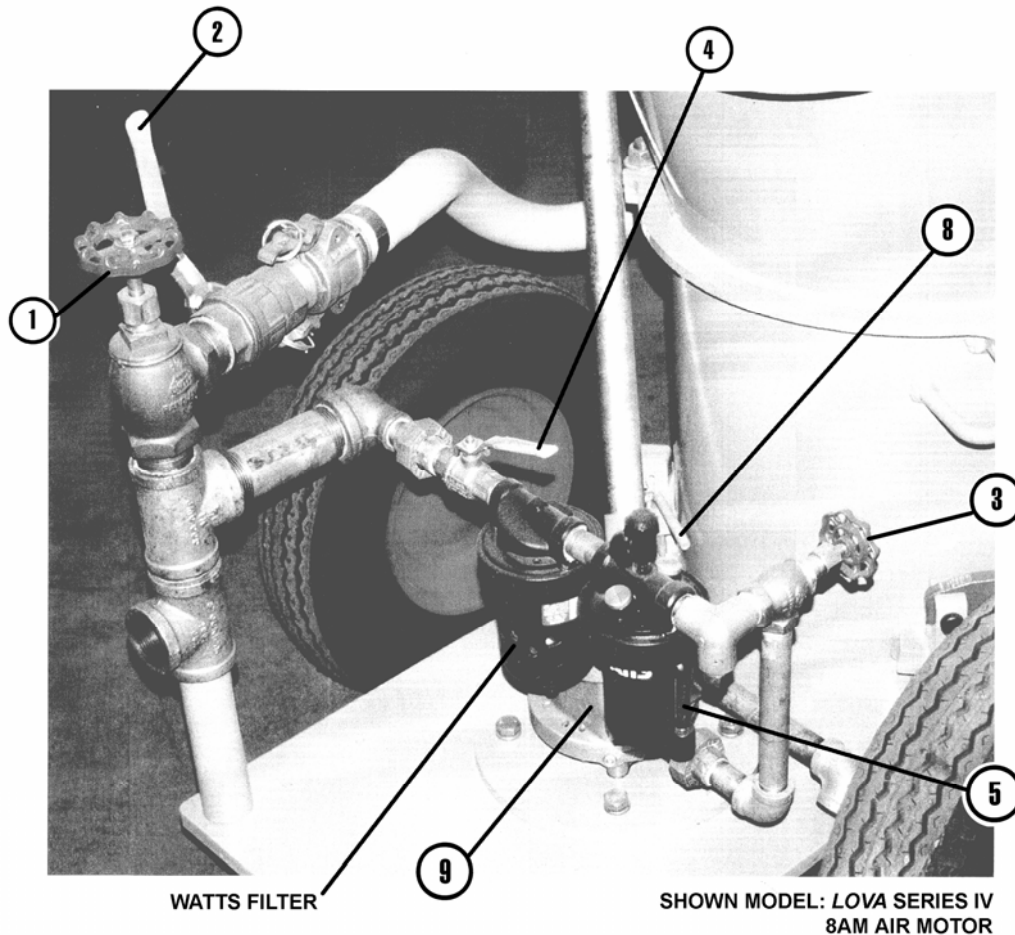

1. THROTTLE VALVE – FEED BOWL

This is a globe type valve and is used to throttle (adjust) the air flow through the feed bowl for exhausting of the material. The throttle valve can be adjusted for a minimum to maximum air flow. Turn knob counterclockwise to **INCREASE** air flow and clockwise to **DECREASE** air flow.

2. MATERIAL FEED VALVE

This is a quarter turn valve used to control the air flow (**ON-OFF**) through the feed bowl. This permits the operator to turn the air on-off without disturbing the setting of the throttle valve. Valve is closed (**OFF**) with handle turned perpendicular to the pressure line and open (**ON**) with the handle turned in a parallel position to the pressure line.

3. THROTTLE VALVE – AIR MOTOR

This is a globe type valve and is used to throttle (adjust) the air flow to the air motor for its operation. The throttle valve can be adjusted for a minimum to maximum air flow. Turn knob counterclockwise to **INCREASE** air flow which in turn increases the RPM of the motor and feed bowl and clockwise to **DECREASE** the air flow or speed.

4. AIR MOTOR VALVE

This is a quarter turn valve used to control the air flow (**ON-OFF**) to the feed bowl. This allows the air to be turned on-off, starting-stopping of motor, without disturbing the setting of the air motor throttle valve. Valve is closed (**OFF**) with handle turned perpendicular to the pressure line and open (**ON**) with handle turned in a parallel position to the pressure line.

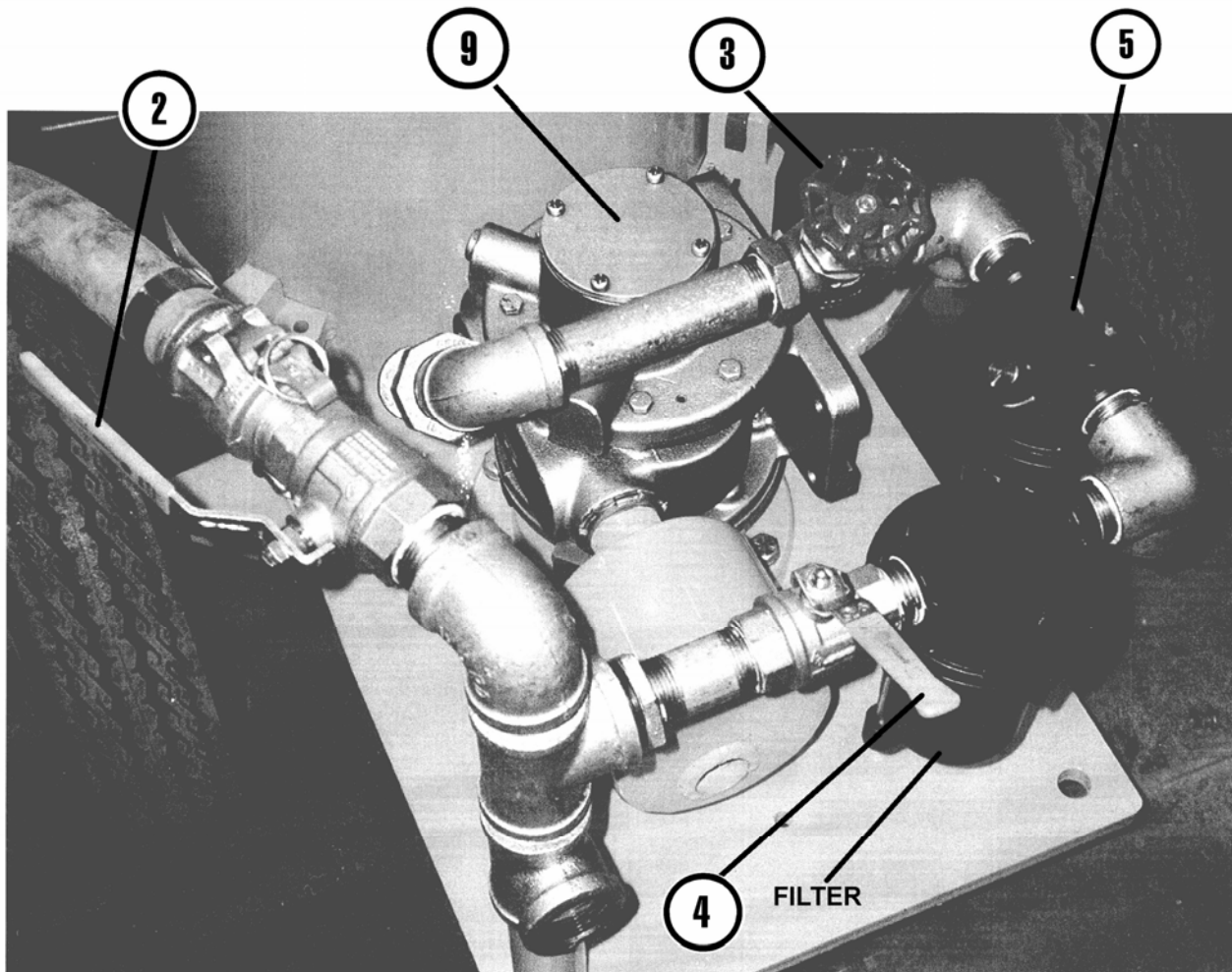

SHOWN MODEL: LOVA SERIES IV
16AM AIR MOTOR

5. LUBRICATOR

Located on the air supply line to the air motor is an air filter and lubricator. These components are installed as protection for the air motor. The lubricator is equipped with a means to adjust the drip rate of oil into the air system. The top of the lubricator is equipped with the adjustment knob. Turn knob counterclockwise to **INCREASE** feed rate, clockwise to **DECREASE** feed rate. Adjust oil drip to two (2) drops per minute as a start. Drops are visible through the sight glass.

6. PAD ADJUSTMENT KNOBS

Three (3) knobs are located on top of the pad housing at the gooseneck. These knobs are used to adjust the sealing wear pad. The left knob adjusts the exhaust side of the sealing pad; the center knob adjusts the rear of the pad and the right knob adjusts the right side of the pad. Turn knob clockwise to increase pressure on pad and counterclockwise to decrease pressure on pad.

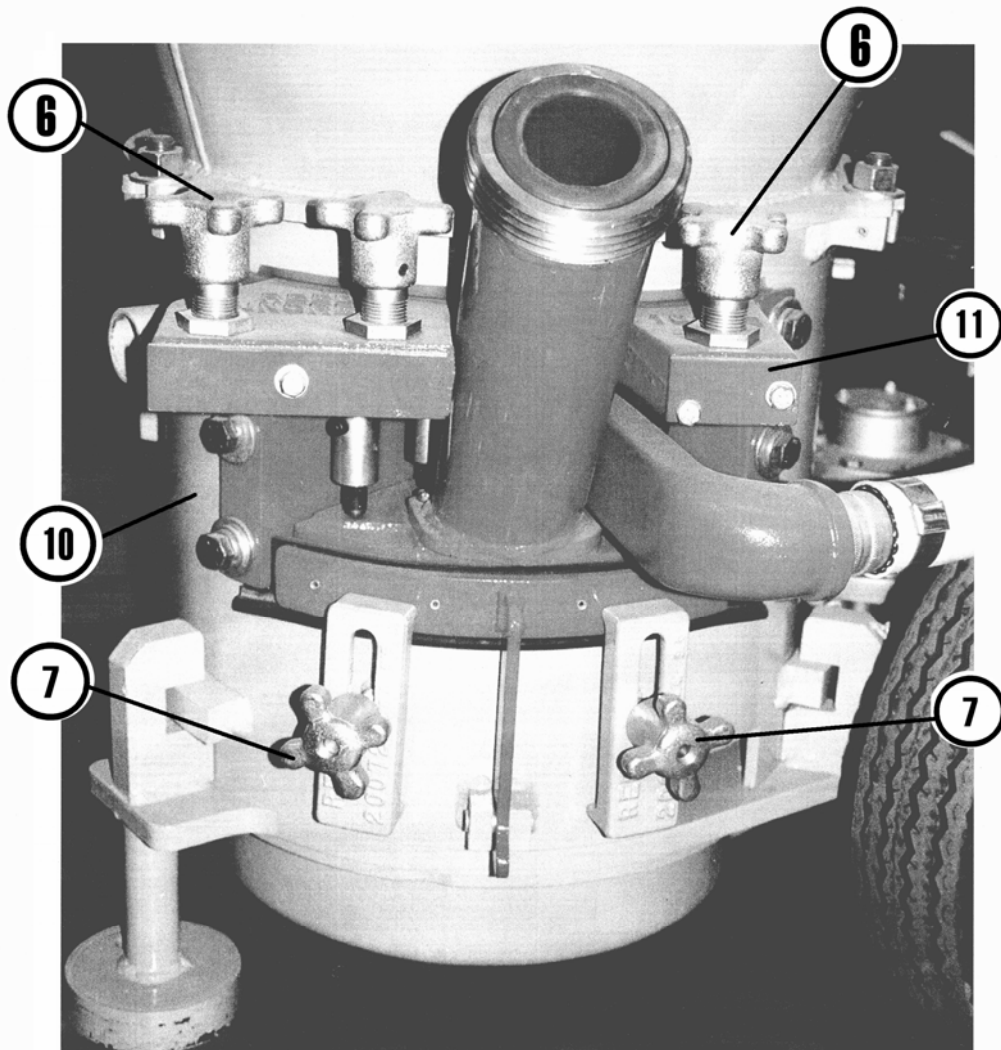

7. PAD HOUSING SEAL KNOBS

Located just beneath the gooseneck are two (2) clamping knobs. These knobs are used to apply the necessary pressure to the curved outside surface of the rubber pad housing.

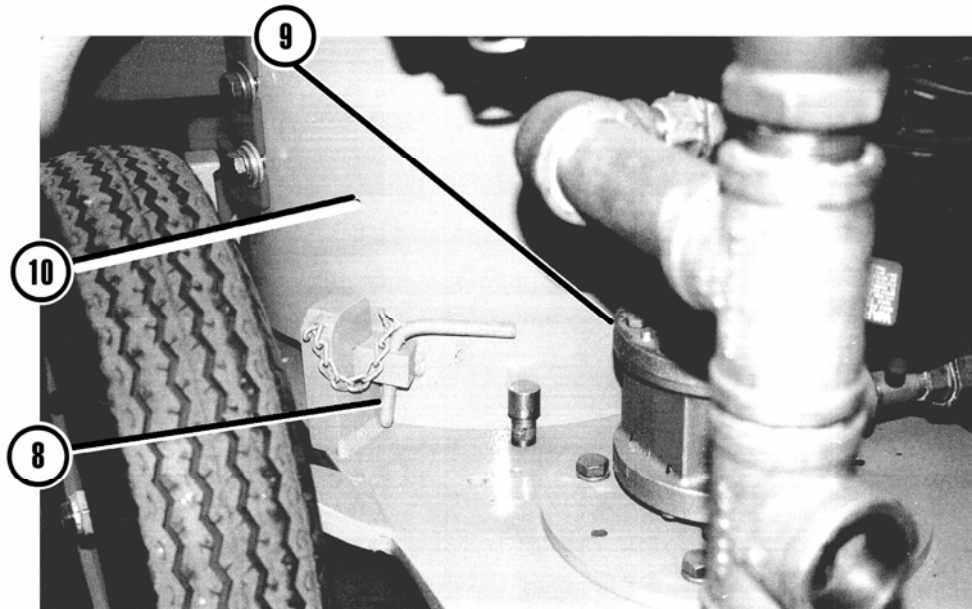

SHOWN MODEL: *LOVA™ SERIES IV*
8 AM AIR MOTOR VALVE

8. FEED WHEEL HOUSING LOCK

The feed wheel housing is secured to the base by use of heavy duty lugs. To remove the feed wheel housing, it is necessary to rotate the housing to free the locking lugs. To facilitate the breaking loose and rotation, a kick bar or foot pedal is provided. Pushing down on lever will apply pressure to locking lug, rotating housing.

9. AIR MOTOR

The *LOVA™ SERIES 4* can be equipped with a 5HP designated 8AM or a 9HP designated 16AM air motor. The motors are designed and manufactured to **REED** specifications and offer precise speed control for operational power of the feed wheel which is highly important in that it permits an even flow of material through the delivery hose as required for the application.

The 8AM motor is of the four (4) vane type and is suitable for most general gunning applications. The 16AM larger motor is of the six (6) vane type and develops greater torque for use on applications where metering of high volumes of large aggregates or



MODEL: LOVA PNEUMATIC SPRAYING MACHINE

OPER.

PAGE 07

high density of material is required. It should also be realized that the 16AM motor will consume and require a much larger compressed air source. (90 CFM)

10. FEED WHEEL HOUSING

The feed wheel housing is the circular tube like component that locks to the base plate assembly and is used to enclose the feed bowl and wear plate, if used. It is also used as the support or mounting structure for the hopper.

In an effort to prevent the leakage of material and dust to areas under the feed bowl, a felt seal is used. The feed wheel housing contains, on it's inside, a retainer ring. The retainer ring is used to hold the felt seal in place. The felt seal which is saturated in oil is installed in the ring and is used to close the gap between the outer surface of the feed bowl or wear plate and feed wheel housing.

11. PAD HOUSING

The pad housing is the pie wedge like component that is mounted to the feed wheel housing and seals off a portion of housing preventing a direct entrance of falling material into the area.

The pad housing assembly consists of the pad clamping mechanism, which applies pressure for a positive pad seal, a pad back-up plate to which the inlet manifold and gooseneck are installed and a pad seal clamping system.

12. FEED BOWL

The feed bowl is that component which resembles a bowl on the outside and contains a number of pockets on the inside. The bowls normally used on the **LOVA™ SERIES 4** are the 12, 15, 15LA, 20, 21, and 30 pocket and usually the application, type of material and size of aggregate will determine which feed bowl will be best suited. In addition to the steel feed bowls, which, except for the 30 pocket, requires a steel wear plate. The feed bowls are also available in urethane except for the 30 pocket bowl.

The urethane feed wheels, when used with damp material applications, reduce the material build up and sticking during operation. The urethane feed wheels do not require a separate steel wear plate as this is an integral part of the urethane feed wheel.

INTERCHANGEABLE FEED OPTIONS FOR REED LOVA GUNCRETE MACHINES

Large Aggregate 12 Pocket Feed System with 10336 or 10337 Rubber Wear Pad; wire fiber mixes, up to $\frac{3}{4}$ inch aggregates, 2 inch and 2½ inch material hoses.

10796 Wear Plate – 10797 Feed Bowl
10922 Rock Cone – 10014 Rock Shear

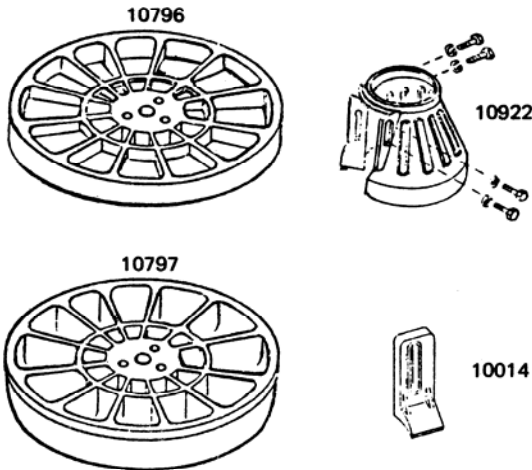

Large Aggregate 12 Pocket Feed System with 10336 or 10337 Rubber Wear Pad; Wear Plate and Feed Bowl are "dividerless" for gunning wire fiber mixes, up to $\frac{3}{4}$ inch aggregates, 2 inch and 2½ inch material hoses.

10798 Wear Plate – 10799 Feed Bowl
10922 Rock Cone – 10014 Rock Shear

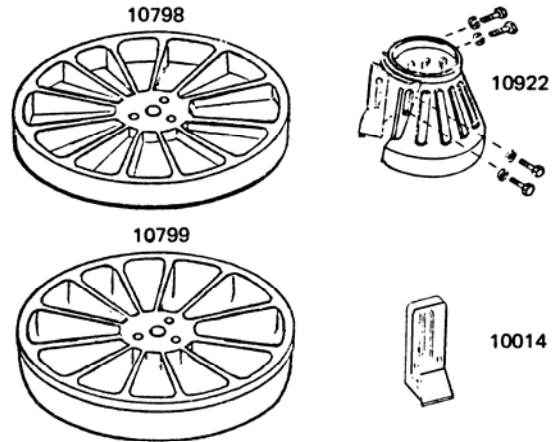

Large Aggregate 15 Pocket Feed System with 10336 or 10337 Rubber Wear Pad; 1¼ inch wire fiber mixes, up to $\frac{3}{4}$ inch aggregates, 2 inch and 2½ inch material hoses; smooth high volume, extreme applications.

10802 Wear Plate – 10803 Feed Bowl
10922 Rock Cone – 10014 Rock Shear

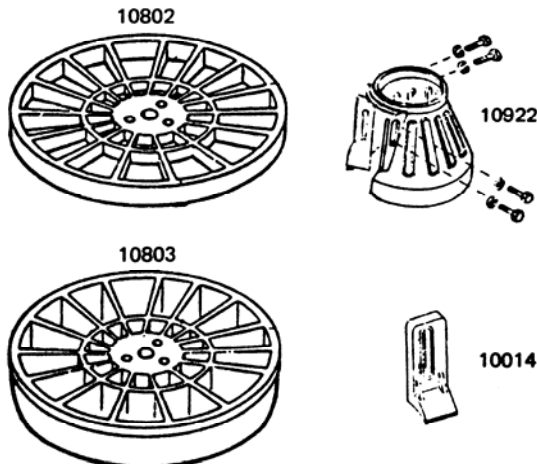

Large Aggregate 15 Pocket Feed System with 10337 Rubber Wear Pad; Feed Bowl is "dividerless", for gunning high proportions of large aggregate; 2 inch and 2½ inch material hoses.

10802 Wear Plate – 10804 Feed Bowl
10922 Rock Cone – 10014 Rock Shear

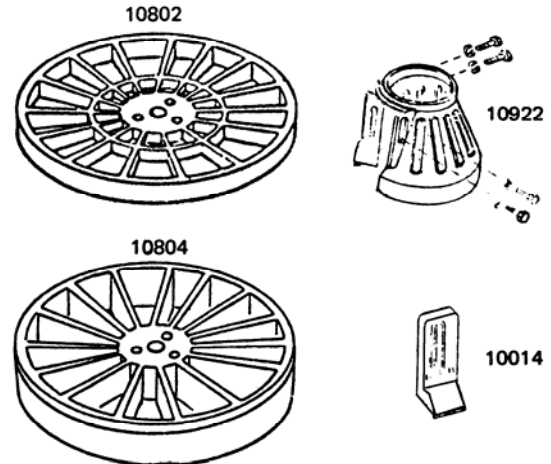



MODEL: LOVA PNEUMATIC SPRAYING MACHINE

INTERCHANGEABLE FEED OPTIONS FOR REED LOVA GUNCRETE MACHINES

Standard 15 Pocket Feed System with 10338 Rubber Wear Pad; 1 inch wire fiber mixes, up to 1/2 inch aggregates, 1 1/2 inch and 2 inch material hoses; smooth high volume, general gunning.

10800 Wear Plate – 10801 Feed Bowl
10013 Rock Shear

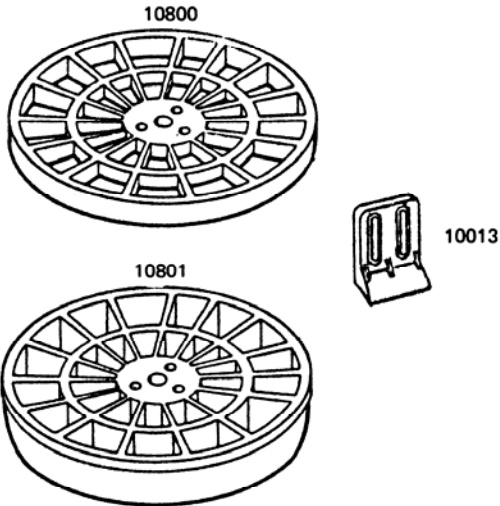

Standard 20 Pocket Feed System with 10338 Rubber Wear Pad; 3/4 inch wire fiber mixes, aggregates up to 1/2 inch, 1 1/2 inch material hose; smooth flow at high or low volume; general gunning.

10805 Wear Plate – 10806 Feed Bowl
10013 Rock Shear

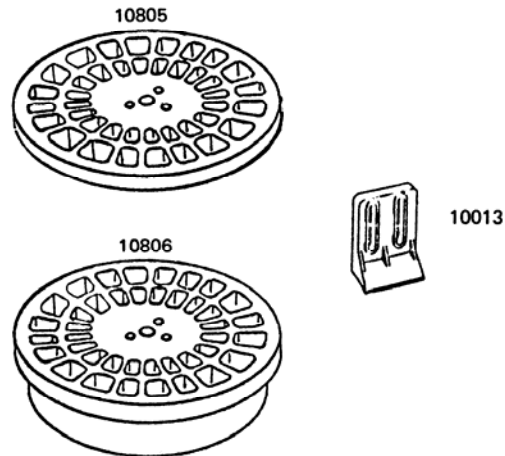

Shallow 21 Pocket Feed System with 10339 Rubber Wear Pad; 1/2 inch wire fiber mixes, up to 1/4 inch aggregates, 1 inch and 1 1/4 inch material hoses; smooth low volume gunning.

10807 Wear Plate – 10808 Feed Bowl
10013 Rock Shear

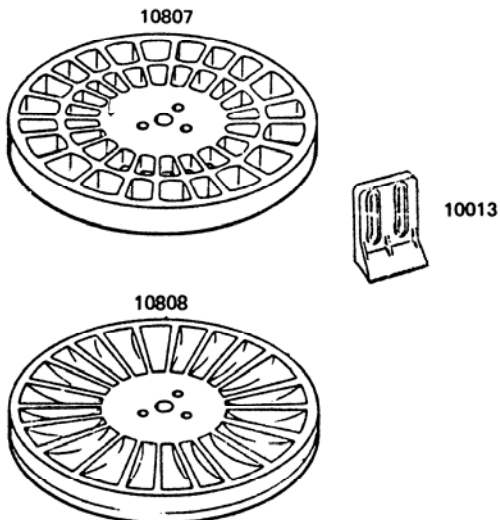

Shallow 30 Pocket Feed System with 10339 Rubber Wear Pad; fine grained materials, 3/4 inch and 1 inch material hoses; very low output, for patching or filling small areas. No Wear Plate used.

10809 Feed Bowl only
10013 Rock Shear

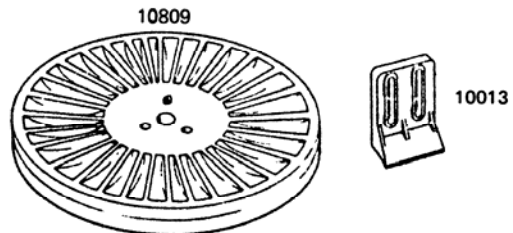

NOTE: WHEN 30 POCKET FEED BOWL IS USED NO WEAR PLATE IS REQUIRED. THIS FEED BOWL IS MOUNTED DIRECTLY ON TOP OF ANY OTHER FEED BOWL.



MODEL: LOVA PNEUMATIC SPRAYING MACHINE

OPER.

PAGE 10

REED GUNCRETE ACCESSORIES

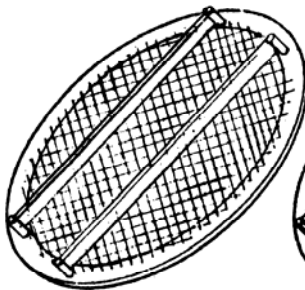
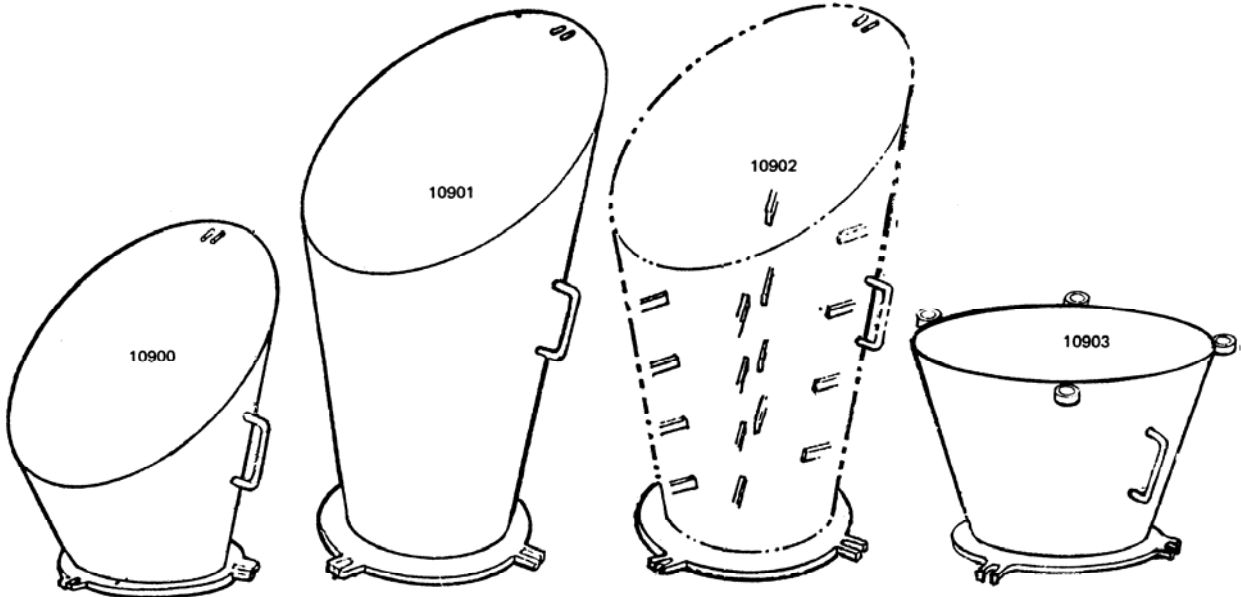

10905
OR
10906

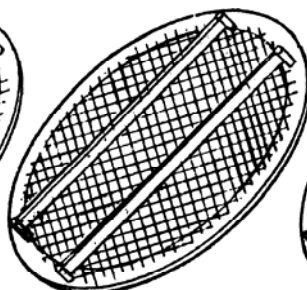

10905
OR
10906

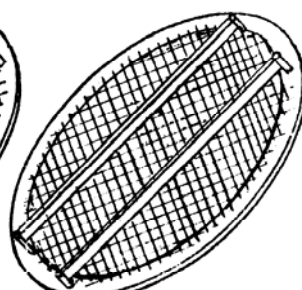

10905
OR
10906

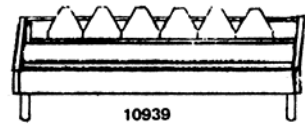

10939

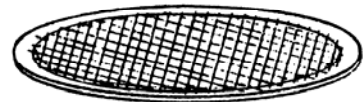

10907

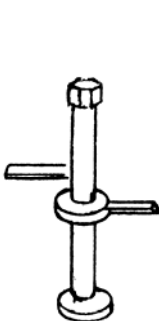

10810

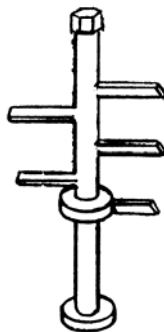

10811



10812

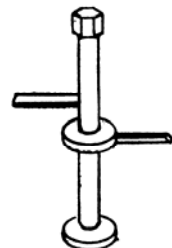

10810

REVISION:

13. HOPPER

The hopper is installed on top of the feed wheel housing and is used to contain the material as it works its way into the feed bowl. The refractory hopper is a continuous feed type with a screen and a bag breaker. The machine can also be equipped with optional hoppers in place of the refractory hopper, such as tall pre-mix; short pre-mix; standard mixer hopper.

In addition to the hopper options, the unit can be equipped with different agitators. The refractory and short pre-mix agitator is the 2-blade agitator. In addition the 2-blade agitator can be used with the tall pre mix hopper as well as a 5-blade. A 30-blade agitator is used with the standard hopper.

14. ROCK SHEAR – ROCK CONE

The rock shear and rock cone, if used, is installed in the pad housing assembly. The rock shear is used to strike off material/rocks to an even level of the feed wheel or wear plate before entering the pad area. The rock cone offered as an option is used to divert oversized material/rocks to the larger outer pockets of the feed wheel or wear plate. When rock cone is used it will be necessary to use the narrow rock shear.

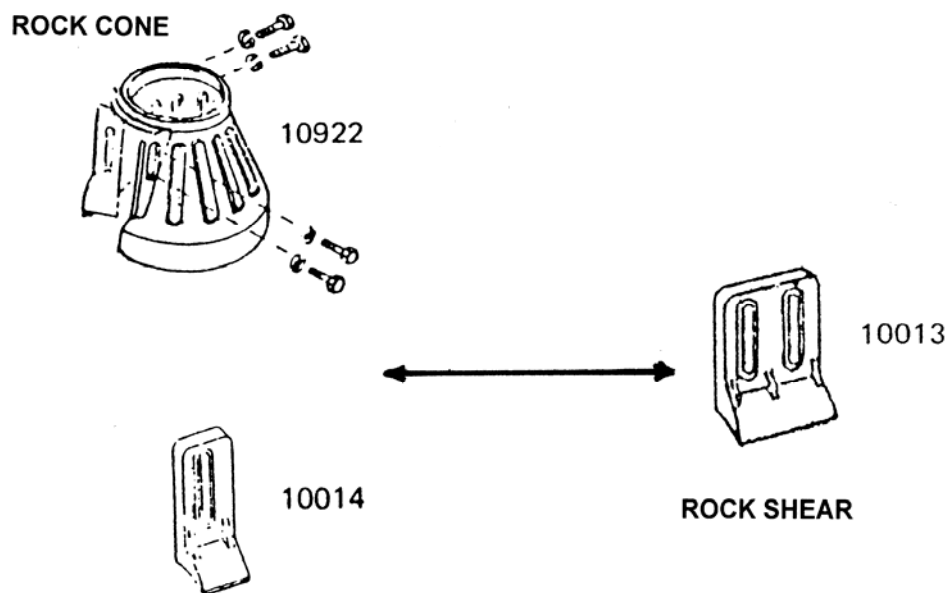



MODEL: LOVA PNEUMATIC SPRAYING MACHINE

OPER.

PAGE 12

OPERATION INSTRUCTIONS

Having **READ** and **UNDERSTOOD** the previous pages on **SAFETY** and **CONTROL FAMILIARIZATION**, you are now in a position to learn how to operate the **REED GUNCRETE LOVA™ SERIES 4**. If you have not read the previous pages, we suggest you do so before proceeding.

⚠ CAUTION

*For your own **SAFETY** and others around you, it is your **RESPONSIBILITY** to insure the unit is in proper working condition. Check out the unit by using the **PRE-OPERATION INSPECTION** notes previously identified.*

⚠ WARNING

OBSERVE ALL SAFETY PRECAUTIONS WHILE OPERATING THIS MACHINE.

SET UP AT JOB SITE

Your first and primary concern when arriving at the job site is to insure the machine can be safely operated and it will afford the maximum production efficiency without jeopardizing safety.

- The machine should be located on as level ground as is possible.
- Keep a sufficient distance away from slopes, pits, trenches, and excavations that could breakaway.
- Remove handle bar from front of machine and store. If necessary, place blocks under front leg to provide a firm footing on ground.



MODEL: LOVA PNEUMATIC SPRAYING MACHINE

OPER.

PAGE 13

NOTE

The LOVA™ utilizes compressed air to drive the motor and to convey the material through the hose. As a result, the production and efficiency of the machine is highly dependent on the amount of available compressed air. This needs to be taken into consideration before starting a job. Refer to specifications "GENERAL SECTION" of this manual for suggested requirements.

START-UP OF THE UNIT

- Check that all valves are in the "OFF" position.
- Connect the main source air line from compressor to inlet on manifold. The diameter of the air supply line should be at least equal to the diameter of the conveying line. Make sure connection is tight and secure with safety chain or cable if required.
- Attach material hose to gooseneck and tighten.
- The nozzleman should install on the material hose the nozzle complete with water hook-up to its source.
- Add material to the hopper and alert nozzleman that system is ready.
- On the signal from the nozzleman, fully open material feed valve and **SLOWLY** turn on the feed bowl throttle air valve to the material hose to desired air flow.
- The nozzleman will then slowly turn on the water at the nozzle.
- Fully open the main shut-off valve for the motor, then slowly open the air motor throttle valve.
- Material should now be flowing and nozzleman will then give the necessary signals for the desired air flow and material feed rate.
- Check the oil feed rate from the lubricator to the air motor. Adjust if necessary.
- As spraying continues, maintain a steady flow of material to the nozzle.

REVISION:

SHUT-DOWN OF MACHINE

It is important that the machine be shut down in the proper manner to eliminate the possibility of complications on restart.

- Stop the feed wheel rotation first. This is accomplished by shutting off the **AIR MOTOR VALVE** (to air motor) without disturbing the throttle valve.
- Permit the air from the main line to continue to flow to the gooseneck and material hose until all material has been blown out. Shut off **MATERIAL FEED VALVE** to system.
- Following this, the nozzleman may now shut-off the water at the nozzle.
- As water is being turned off, hold nozzle and point down toward ground to prevent any water leakage from running back into the material hose.
- Shut down main source of air.



LOVA SERIES IV WITH REFRACTORY HOPPER



MODEL: LOVA PNEUMATIC SPRAYING MACHINE

OPER.

PAGE 15

OPERATIONAL TROUBLESHOOTING TIPS

This Operational Troubleshooting Tips section is designed to assist you in recognizing the symptom, providing a probable cause and suggested corrective action. The items listed are based on logical symptoms from our experience as well as that of our users.

A) Symptom – Excessive Air Blowing Up and Out of Hopper

Corrective Action

- Adjust rubber pad pressure by tightening the three (3) adjustment knobs to provide a positive seal.
- Inspect rubber sealing pad. It may need to be replaced.
- Check installation of rubber wear pad. Make sure rubber portion is down against top of urethane feed wheel or steel wear plate, if used.
- Top of urethane feed wheel, if used, or top of steel feed bowl and/or wear plate may be worn and needs to be resurfaced or replaced.
- Foreign material may be clamped or lodged between steel feed bowl and wear plate. This would permit air to blow between the two (2) parts and escape into hopper.
- No sealant installed between worn side of wear plate and feed bowl.
- Agitator not securely tightened.

NOTE

If the above condition is allowed to continue without remedy, premature failure of the rubber pad, feed bowl, or wear plate will occur and as a result will create even more noticeable discharge of air back into the hopper or atmosphere. Do not confuse pocket exhaust with seal failure. Pocket exhaust is rhythmic puffing which should not cause material to be blown out of the hopper.



MODEL: LOVA PNEUMATIC SPRAYING MACHINE

OPER.

PAGE 16

B) Symptom – Insufficient Volume to the Nozzle

Corrective Action

- Pad not completely seated in the pad housing. Pad must be inserted far enough into pad housing to allow the inlet and outlet ports of the pad to align with the feed wheel pockets. When pads are removed, wear patterns should be regularly checked to assure the sealing portions of the rubber face are in alignment with the outer rim, the center divider and the inside hub portion of the feed bowl or wear plate
- Inadequate air supply or pressure

C) Symptom – Excess Material Leaking to the Ground from Around Feed Bowl on Lower Edge of Feed Wheel Housing

Corrective Action

- Felt ring inside wheel housing is not pushed down close enough to the top of the feed wheel.
- Check condition of felt seal. It may be hard and dry from the lack of regular cleaning and oiling. Adjust felt pressure. See **ADJUSTMENT SECTION**.

D) Symptom – Surging Material through the Hose and Nozzle.

Corrective Action

- Feed wheel spinning too fast resulting in too much material being discharged into material hose for the amount of air being used. Adjust RPM of feed wheel or increase air.
- Some pockets in the feed wheel may be plugged.
- The pockets in the feed wheel may be too large for the small diameter hoses.
- Material may have a high moisture content causing the material to bridge above feed wheel causing material to feed sporadically.
- Insufficient air supply
- Uneven feed rate maintained into the hopper by material loading system.

E) Symptom – Feed Wheel Running Too Slow or Stops

Corrective Action

- Insufficient air supply to motor. Check air motor valve that it is fully opened. Check motor throttle valve that it is set properly.



MODEL: LOVA PNEUMATIC SPRAYING MACHINE

OPER.

PAGE 17

- Check that compressor is of sufficient size for the intended operation.
- Check air filter at motor that it is not plugged.
- Check for possible obstruction in feed wheel.
- The air muffler is iced, restricting the air flow through the motor. If it is necessary to remove the muffler, make sure a plug or cap is installed during service in its place to prevent the entrance of foreign material into the motor.
- Check the pressure on the pad clamp that it is not too tight.
- Vanes in air motor may be worn out. Never operate motor without the air filter or lubricator in proper working condition.

F) Symptom – Excess Rebound When Spraying

Corrective Action

- Using a poor nozzle spraying technique. Water to cement ratio is out of balance. Improper angle or distance to work face.
- Plugged water ring or water chamber in the nozzle assembly.
- Imbalance of sand, water, and cement ratio.
- Mixture too dry or wet
- Contamination of the mix and/or water.
- Excessive large aggregate, fiber, or wire mesh.

G) Symptom – Hose Blockage

Cause – Often the cause of hose blockage is the result of:

- Using oversize material
- Operating with an insufficient supply of air
- Feeding the hose too much material
- A prehydration of the material inside the hose
- Not clearing the hose after turning off material feed
- Sharp bends or kinks in the hose
- Improper coupling of hose ends
- Faulty hose (Liner separation from outer hose jacket.)

Corrective Action – Clearing a Hose Blockage

When a line blockage occurs, turn off air and start searching for the point of blockage beginning at the nozzle and working back toward the machine. The hose will continue to be soft from the nozzle to the point of blockage. When blockage has been found bend or pound on the hose carefull not to damage hose at that point to free the blockage. Slowly turn on the air.



MODEL: LOVA PNEUMATIC SPRAYING MACHINE

OPER.

PAGE 18

▲ WARNING

Exercise EXTREME CARE when attempting to blow the material clear using air. ALWAYS have the nozzle end securely held and have a person at the machine who will be ready to cut back on the air if and when required.

H) Symptom – Insufficient compressed air

Corrective Action – How Much Air is Enough?

Most problems occurring on the average gunning jobs are the result of improper application of air or insufficient amount of air.

- Make sure the compressor is of adequate size, is properly adjusted and capable of producing maximum capacity.
- Multiple compressors may be used to gain the required volume of air. In this situation, the compressors should be arranged so that they discharge into a certified central air receiver. From this a single air line of proper size can then be run from receiver to machine.
- Always supply the machine with the same size air supply hose as the material hose being used for gunning. Multiple small hoses often do not have the carrying capacity of a single larger hose.
- Make sure all valves are open between the air source and machine. Check that supply line is free of kinks or blockages.
- Run material hoses from the machine to the nozzle in as straight a line as is possible. This will improve the flow characteristics and reduce wear.
- Exercise caution when coupling hoses that no foreign objects are present or restrictions at point of connection.
- Always use good premium hose specially manufactured for gunning applications.
- The amount of air flow being received can be tested for proper volume as follows when flow meter or orifice testers are not available:
 - With hopper empty of material and having the pad loosely clamped, open main air valve to full open position.
 - Open the air motor main valve and the throttle valve to full open.
 - The air motor should reach full RPM without hesitation. If air motor does not come to full RPM, the air supply to the machine is marginal. This condition could result in a marked decrease in the volume of material introduced into the air stream within the machine and out of the material hose.



MODEL: LOVA PNEUMATIC SPRAYING MACHINE

OPER.

PAGE 19

CLEAN UP OF THE MACHINE

This sometimes may seem tedious, tiresome, and a distasteful task, however, the clean up is a **VERY IMPORTANT** operation. We pointed out previously the importance of the pre-operation inspection. The clean up is no different because it sets the stage as to how well the machine will perform the next time it is used. The machine should be thoroughly cleaned after each day's use. The following is a suggested procedure:

- Disconnect the material delivery line.
- Using a water hose, wash down the inside of the hopper removing any residue of material, Turn off water.
- Turn on main material feed air valve.
- Turn on air motor valve and throttle down the air so that feed bowl slowly rotates and allows the air to blow out the water and material.
- Turn off air to feed bowl and air motor and disconnect air hose at gooseneck.
- Loosen the two (2) knobs used to adjust the pad housing seal until vertical clamps slide down enabling seal to be swung free.
- Remove gooseneck with pad back up assembly.
- It is suggested that the rest of the machine be disassembled for final cleanup.
 - Remove screen, agitator, feed wheel housing, steel wear plate, if used, feed bowl and riser plates.
- Clean and lubricate as necessary and reassemble.

After thoroughly cleaning machine, reassemble parts and tilt hopper back in place.



MODEL: LOVA PNEUMATIC SPRAYING MACHINE

PREVENTATIVE MAINTENANCE

How good is any of the equipment you own? It is only as good as it is **MAINTAINED**. Even the finest equipment manufactured requires attention and care. The **REED GUNCRETE LOVA™ SERIES 4 Machine** is no different. A good well planned and carried out preventative maintenance program will enhance a properly operating unit as well as the safety of those operating and using the equipment.

It is very important to establish a good maintenance program. Costly repairs and loss of revenue can often be avoided by planning ahead, setting a regular schedule and exercising good preventative maintenance techniques.

NOTE

All points noted herein regarding the maintenance and checks are not intended to replace any local or regional regulations which may pertain to this type of equipment. It should also be noted that the list and schedule is not considered to be inclusive.

⚠ CAUTION

It is your responsibility to always insure that the applicable safety precautions are strictly observed when performing the inspections and maintenance checks. Make certain any components that are found to be defective are replaced or those in need of adjustment or repair are correct before operating the machine.



MODEL: LOVA PNEUMATIC SPRAYING MACHINE

MAINT

PAGE 01

SCHEDULED INSPECTION

The main purpose of accomplishing scheduled inspections is to identify and detect any potential malfunction before it can expand into a major problem. In so doing, it will help ensure a good safe unit performance.

1. FRAME AND RELATED COMPONENTS

- Frame integrity, visually check welds for cracks
- Rear wheel mounting, spindle nut tight
- Front support stand in good condition

2. HOPPER

- Visually check for structural damage, cracked welds
- Check condition of screen, attaching hardware
- Check condition of mounting hardware
- Check condition of agitator, structural damage

3. MAIN OPERATING PARTS

- Inspect feed wheel or wear plate for damage
- Check feed wheel top or wear plate for excessive wear
- Wear pad fits properly, installed properly, good seal
- Visually check gooseneck, mounting, connection
- Check pad clamping system
- Inspect felt seal and replace if necessary.

4. AIR MOTOR AND GEAR CASE

- Check oil level in gear case
- Air motor mounting secure
- Connections to motor are tight
- Check condition of air filter
- Check condition of air motor lubricator

5. CONTROLS AND INSTRUMENTS

- All valves open or close easily
- All piping and hose connections are secure and tight

REVISION:

GENERAL MAINTENANCE AND SERVICE

The **REED LOVA™ SERIES 4** is equipped with several components that because of the application require frequent attention. Rapid wear and probable component breakdown will result if the unit is operated with inadequate service.

FILTER – AIR MOTOR

Located under the housing at forward end of the unit is an air filter. The purpose of this component is to remove any liquid and solid particles from the air stream that could damage the air motor.

In operation, the air entering the filter is guided into a swirling pattern by the louvers. The liquid and coarse particles are thrown against the wall of the bowl by centrifugal force and run down to the bottom of the bowl. A baffle creates a quiet zone at the bottom of the bowl to prevent air turbulence from re-entraining separated liquids into the air stream. Air leaving the bowl passes through the element where finer solid particles are removed and retained.

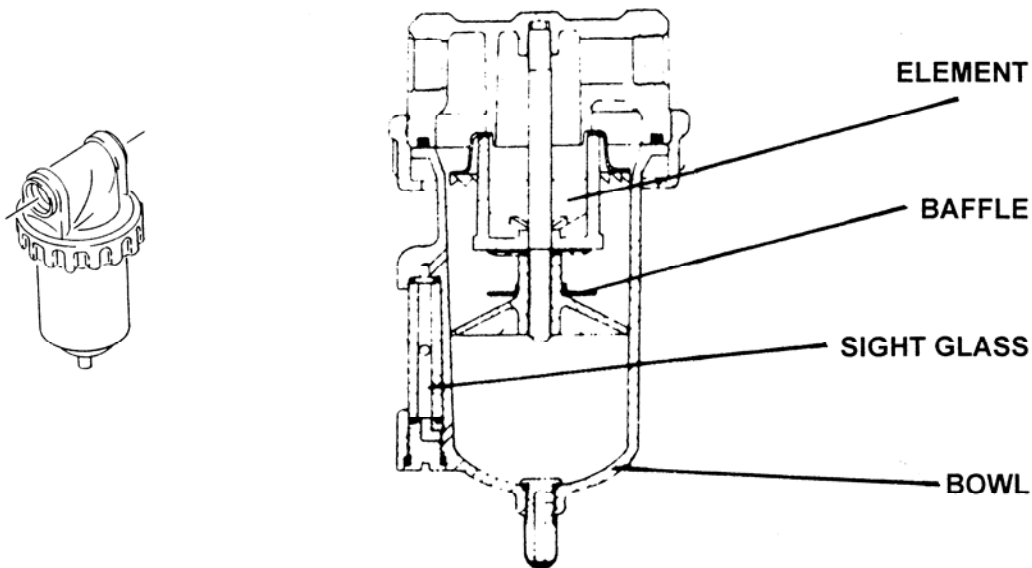

SECTION VIEW

Filter should be cleaned and serviced when sufficient solids and liquids are present inside the bowl. To service the filter, shut off the air pressure going to the motor. To disassemble filter, remove the clamp ring holding the bowl to the body. Exercise extreme care when removing bowl that o-ring is not damaged. Unscrew the baffle which enables the filter element to be removed.



MODEL: LOVA PNEUMATIC SPRAYING MACHINE

Inspect and carefully clean each part using only clear warm water or alcohol. Blow compressed air through filter element from the inside of the element towards the outside to dislodge any surface contaminants.

Reassemble filter, however, **DO NOT OVERTIGHTEN BAFFLE** when replacing element or stud will be stripped from top casting.

AIR MOTOR LUBRICATOR

Located adjacent to the air motor filter is the air motor lubricator. The purpose of this component is to inject in the air stream a type of lubricant that will keep the air motor moving parts lubricated for prolonged service life. The amount of lubricant entering the air stream is adjustable.

The lubricator is equipped with a means to adjust the lubricant drip rate. This drip rate is controlled by an adjusting screw which applies pressure to a felt disc which permits the oil to drip at a desired rate from the drip gland through the sight feed chamber and into the drip line.

Lubricant – Use SAE# 10 Detergent

Drip Rate – Three-Four drops per minute for average condition. A heavy film at or near motor exhaust indicates over lubrication. Lower drip rate.

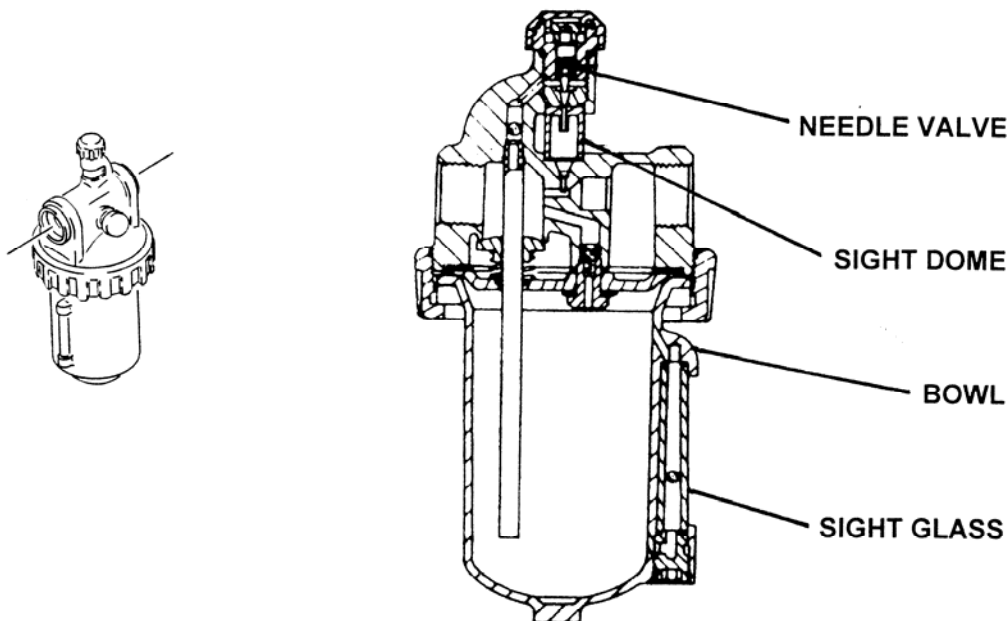

SECTION VIEW

It may be necessary to periodically clean the lubricator. A good indication is when the oil stops dripping through the sight glass even when the knob is on. It is not necessary to remove lubricator from the line for cleaning. To accomplish this, shut off the air pressure

to the lubricator. Disassemble unit by removing clamp ring, thus separating bowl from head casting. Remove bowl and proceed to unscrew siphon tube assembly and check valve assembly. Each of these contains a small ball. Be carefully these are not lost.

Remove the needle valve assembly and unscrew the drip gland using an allen wrench. Push out the venturi tube. Carefully inspect each part and clean in warm water or alcohol. Replace any worn or damaged parts before assembly. **NOTE-** When re-assembling, be certain the arrows on the venturi point in the direction of the air flow.

GEAR CASE

Under and part of the baseplate is a transmission or gear case used to transmit the power from the air motor to the feed wheel for its rotation. The gears are lubricated by running continuously in oil. Based on this, it is important that the level in the gear case be maintained to its proper level. The gear case should be kept at least one-half (1/2) full.

Interval – Check level once a week, sooner if above average usage occurs.
Lubricant – Shell 90 weight gear oil or equal

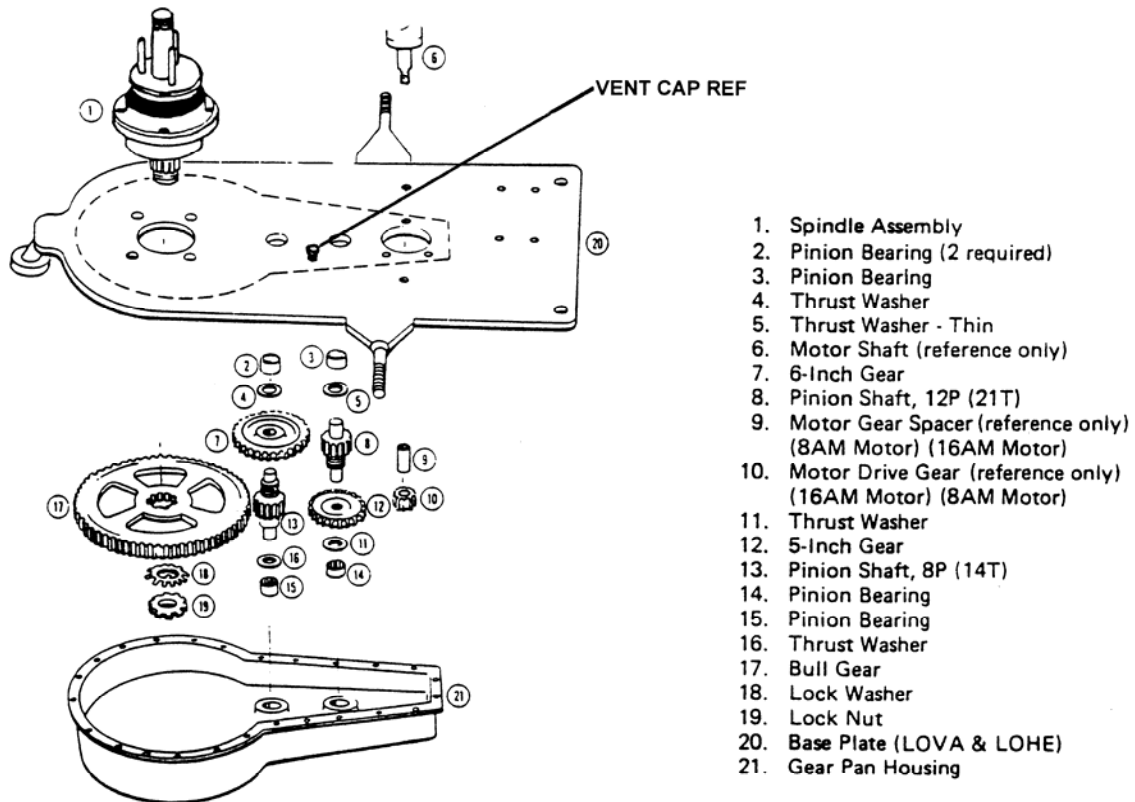

Remove motor cover housing making gear case vent cap accessible. Remove vent cap and check level. Add oil if required. Replace vent cap.



MODEL: LOVA PNEUMATIC SPRAYING MACHINE

ADJUSTMENTS

In the course of using the machine as well as in cleaning, operation, and maintaining, periodic adjustments may be required to continue the factory type performance. The following is offered to assist in accomplished these functions.

RISER PLATE INSTALLATION

The top surface of the urethane feed wheel or steel wear plate is a wear surface which will need to eventually be reground for continued use or replaced totally. As the top surface wears or is resurfaced, the feed wheel needs to be raised to now minimize the space caused by grinding and once again provide a good seal.

To raise the bowl, riser plates can be installed underneath the bowl. At the delivery of each machine, a set of three (3) plates, each of different thickness, thick, medium, and thin are furnished. The plates are double dish blanchard ground parts and may be used in any combination required to elevate the feed wheel to the proper position. Do no substitute with anything less than those furnished by **REED**.

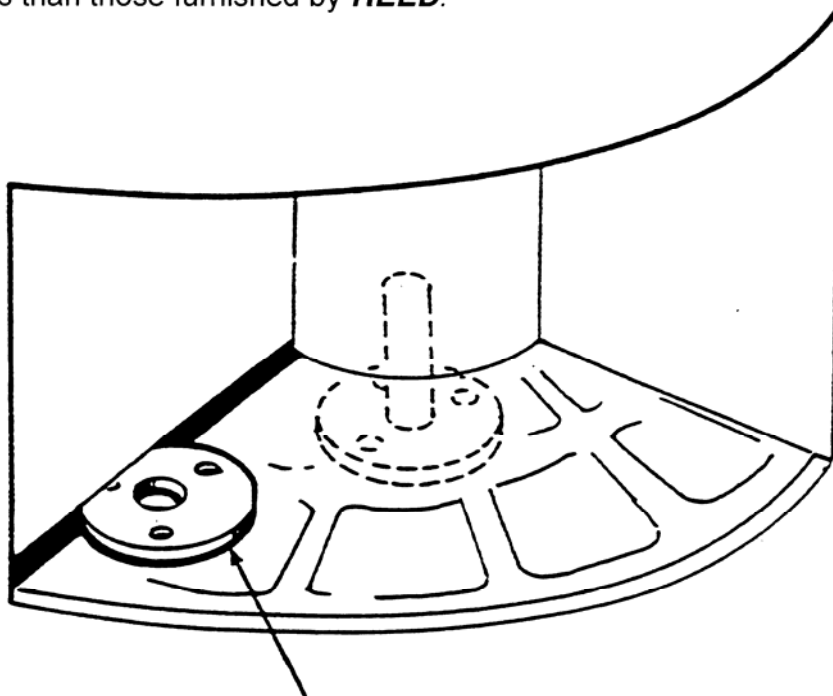

**FOR CHECKING ONLY,
IF THIN RISER PLATE SLIDE IN HERE,
RISER PLATE SHOULD BE PLACED
UNDER FEED BOWL.**

To determine the required riser, insert one of the plates, thick or thin, between the pad housing and the top surface of the feed wheel. After making this check, proceed to install the same thickness of riser under the feed wheel.

NOTE

When a machine has been in use for a period of time, riser plates may have already been installed. These are often difficult to see on the spindle shaft. To dislodge the existing riser plate from the spindle hub, tap lightly around the outer diameter of the hub with a soft faced hammer or mallet until separation of the plates occurs.

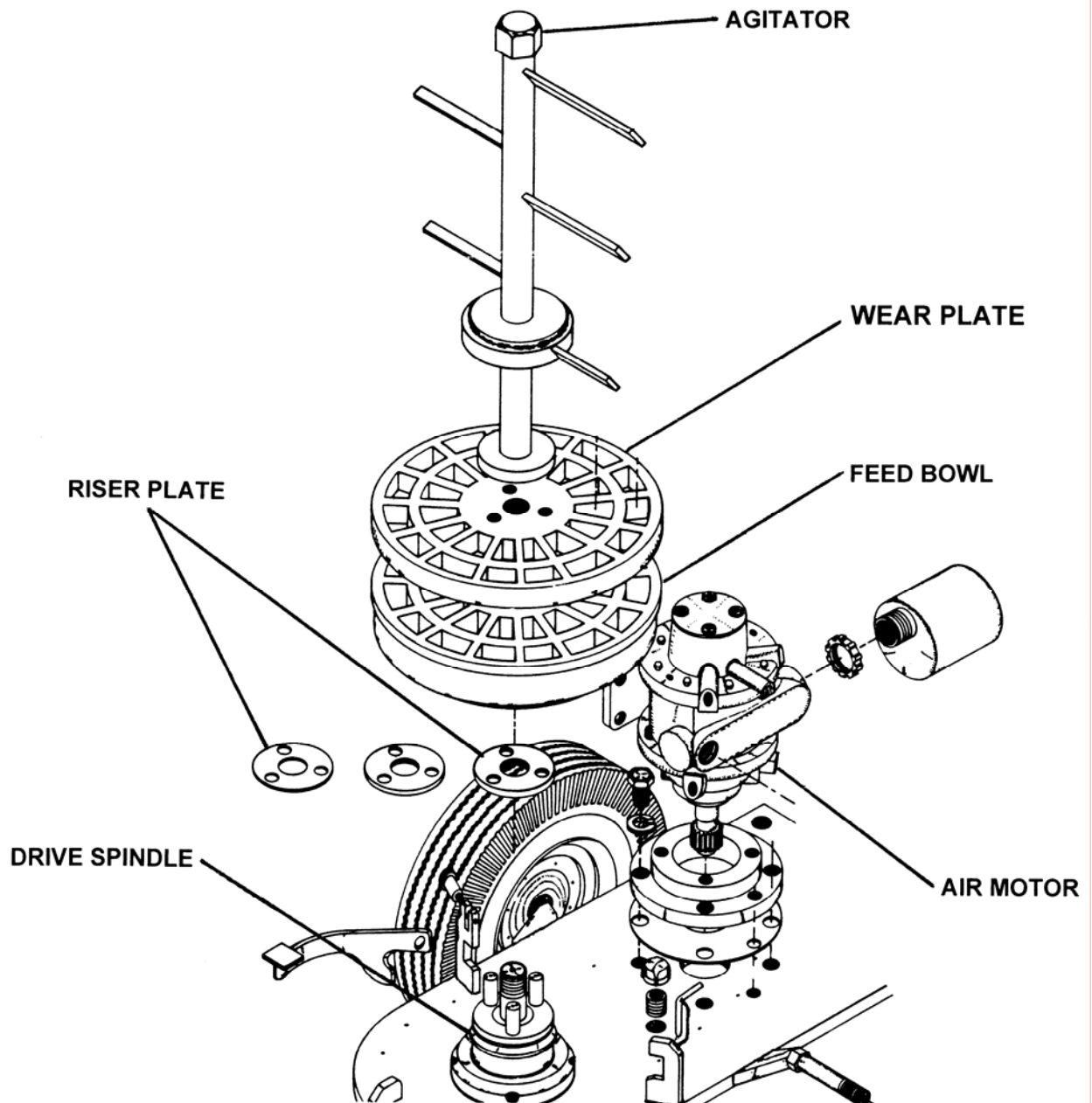

FELT SEAL

Inside the feed wheel housing is a felt seal ring that is used to retain the felt seal in position. The purpose of this felt seal is to prevent material from escaping out of the bottom of the housing assembly. Before installing felt seal, lubricate the seal with oil then install in ring and pack felt seal down from inside hopper.

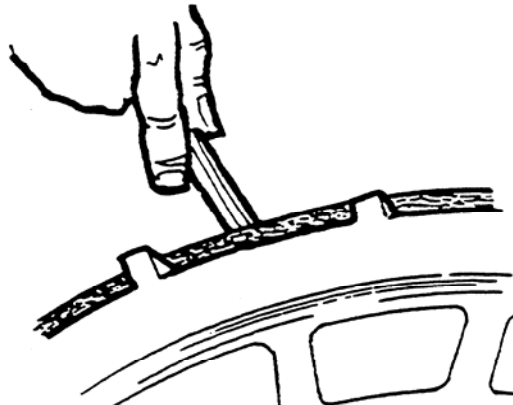

FELT SEAL BEING ADJUSTD TO WEAR PLATE

ROCK SHEAR

Installed on the top side of the feed wheel is a rock shear. The purpose of the rock shear is to act as a wiper in keeping large aggregate from being lodged between the wheel and the rubber pad thus providing increased life of the pad.

The rock shear is adjustable and should be positioned as close as possible to the top of the wheel without allowing to scrape directly on the bowl or wear plate. A common practice is to use a business card as a gauge, placing it between the rock shear and the feed wheel/wear plate. Then tighten bolts starting with the lower bolts first.

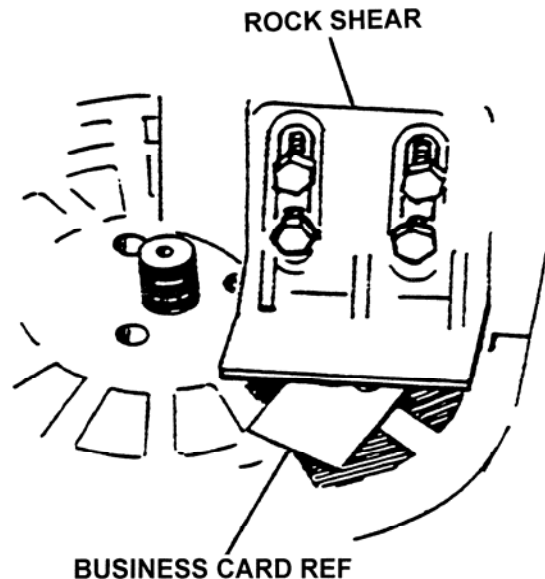

RUBBER SEALING PAD

This component is a major ingredient in the operation of the machine. It is used to seal off all the pockets loaded with material, except for one, allowing the air to be directed to the intake opening of the feed wheel/wear plate and exhausting the material air mixture through the outlet and into the gooseneck. It is a seal, thus the match up of the rubber pad to the back up plate is crucial.

- Make sure the inlet and outlet openings of the rubber pad match the openings of the feed wheel/wear plate.
- The rubber flange ring on top of the pad must fit snugly into the corresponding round hole in the back up plate.
- Make sure that the inlet pipe or nipple attached to the threaded hole in the back up plate is not protruding beyond the underside of the plate (threaded in too far). If nipple protrudes beyond the under surface, it will prevent the sealing pad from mating flat with the back up plate.
- Install wear pad with grease for ease of installation.

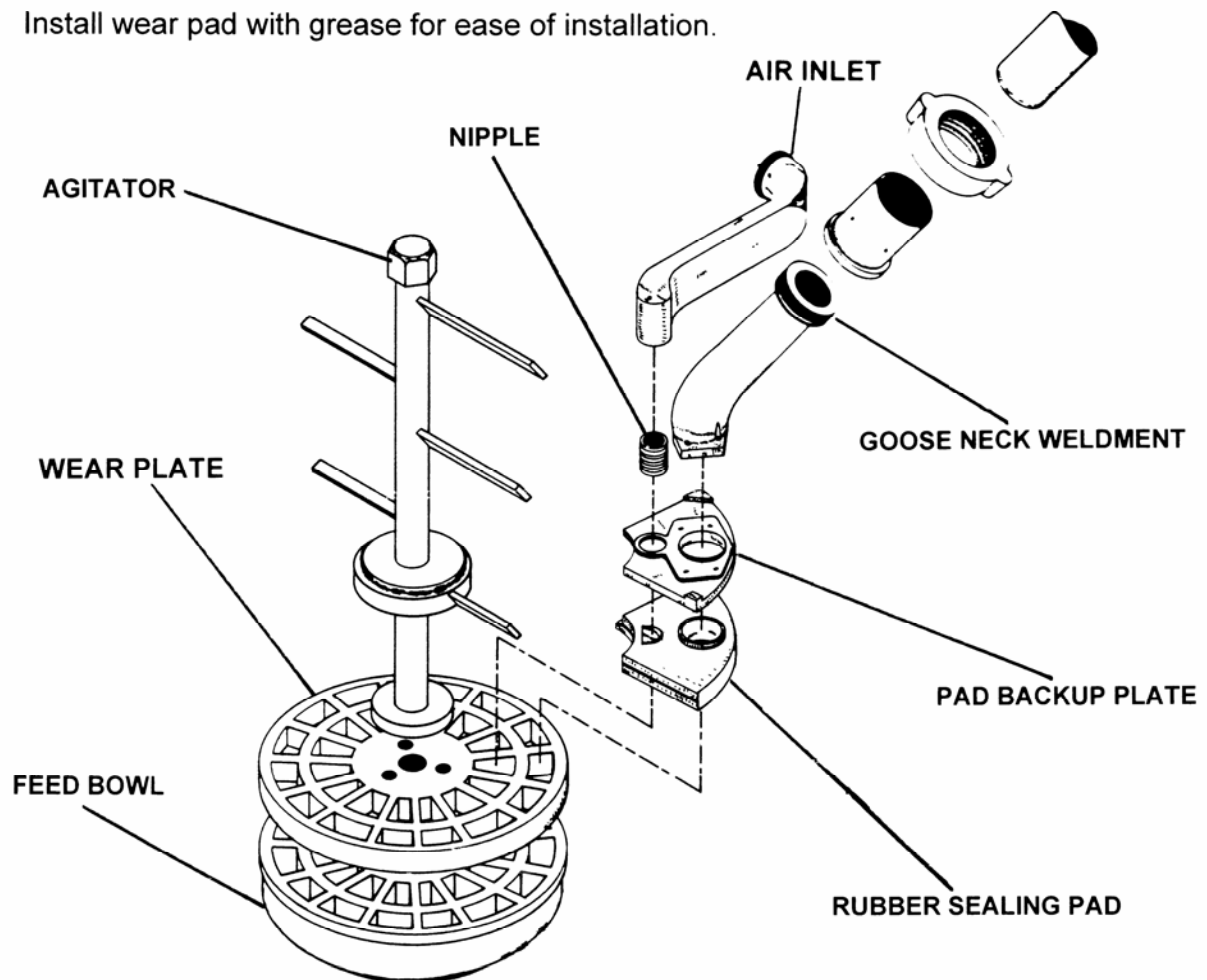



MODEL: LOVA PNEUMATIC SPRAYING MACHINE

MAINT

PAGE 09

PAD ADJUSTMENT

As noted previously, the rubber pad acts as a seal between the back-up assembly and top surface of the feed wheel or wear plate. As a result, the control of excessive dusting during operation and the efficiency for successful gunning is very dependent on the adjustment of the pad.

The adjustment of the pad is accomplished by the use of the adjustment mechanism located on top of the pad housing. This mechanism consists of three (3) knobs each containing a chain and sprocket arrangement for control of the pad adjusting stud. In directly facing the gooseneck-pad housing, the left hand knob is used to adjust the left or exhaust side of the sealing pad. The center knob is used to adjust the rear of the pad and the right hand knob is used to adjust the right side of the pad. Turn knob **CLOCKWISE** to apply pressure moving studs **DOWNWARD**. Turn knob **COUNTERCLOCKWISE** to **RAISE** adjusting studs, to relieve pressure.

NOTE

The initial pad adjustment should be done before the material hose is connected to the outlet or gooseneck and with vertical pad clamps loose.

To adjust the new wear pads:

- Adjust all three (3) adjusting studs **DOWNWARD** turning knobs **CLOCKWISE** until each stud contacts the top surface of the pad.
- Proceed then to turn **CENTER** knob **CLOCKWISE** 1¼ turns to move stud downward.
- Adjust **LEFT** knob 1¼ turns **CLOCKWISE**.
- Adjust **RIGHT** knob 1¼ turns **CLOCKWISE**.
- Make final adjustment and tighten the vertical pad clamps.
- The sealing rubber pad is now secure and the pad housing is ready for start-up.

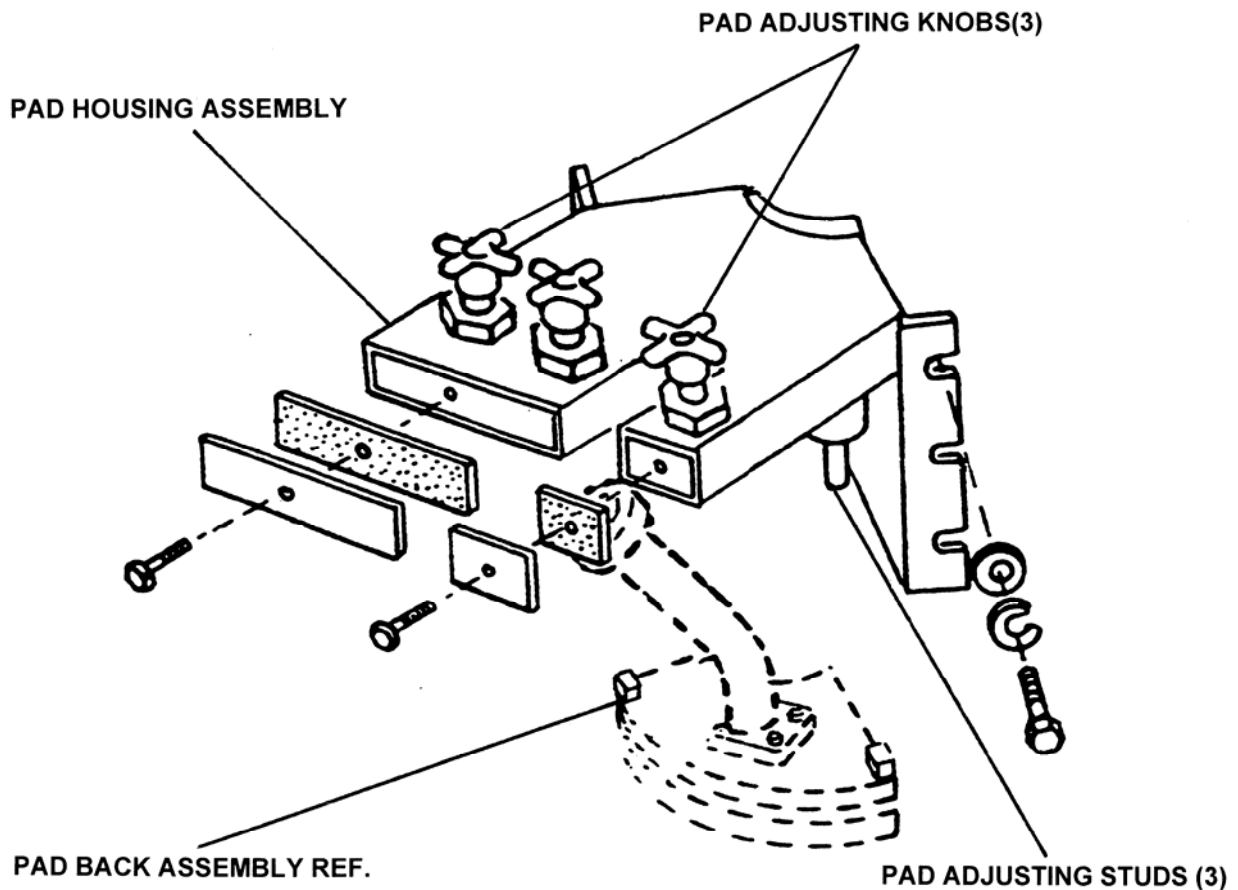

NOTE

*Final adjustment to each adjusting stud may be necessary after machine is in operation. Every effort should be made to keep **DOWNWARD PRESSURE** adjustments on the sealing pad **EQUAL** on the three (3) studs.*

Keep in mind that improper adjustments of downward pressure to one side of the pad over the opposite side, causes excessive wear to the rubber sealing surface and thus results in increased wear. This condition can also allow the pressurized air to escape free from under the sealing pad in the area of least downward pressure. This air blasting, coupled with particles of material or sand can quickly eat into the metal surface and destroy it.

THE FEED BOWL

The top surface is originally ground with a slight concave dish radiating from the center to the outside edge, measuring 0.002 inches (0.05 mm) to 0.005 inches (0.13 mm). The bottom surface of the feed bowl must be maintained free of any disfiguration. This bottom surface is used to locate the part in the grinder when it becomes necessary to resurface the top face. If there are severe knicks on the bottom surface of the feed bowl that cannot be removed evenly with a file, then we recommend lightly filing the top surface free of burrs and knicks and place the top surface down in the grinder and Blanchard grind the bottom surface first. Then turn the feed bowl over and dish the top surface.

THE STEEL WEAR PLATE

After a certain amount of use the hardened steel wear plate will show signs of wear. We recommend Blanchard grinding the worn surface after 1/32 inches (0.8 mm) of wear.

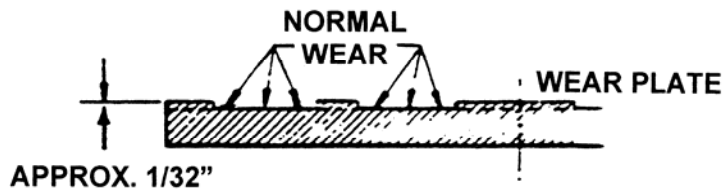

When sending the wear plate out for grinding instruct the grinder to Blanchard grind to 100% dean up. Both surfaces are to be ground flat and parallel within 0.002 inches (0.05 mm). It is not uncommon to resurface two thin wear plates and tack weld them together using nickel welding rod. The combined thickness of the two used plates should not exceed the thickness of one new wear plate, and they should be resurfaced in the above manner after they are welded together. Exercise extreme caution to property index both plates perfectly before welding together, as it is impossible to re-drill any holes for re-alignment

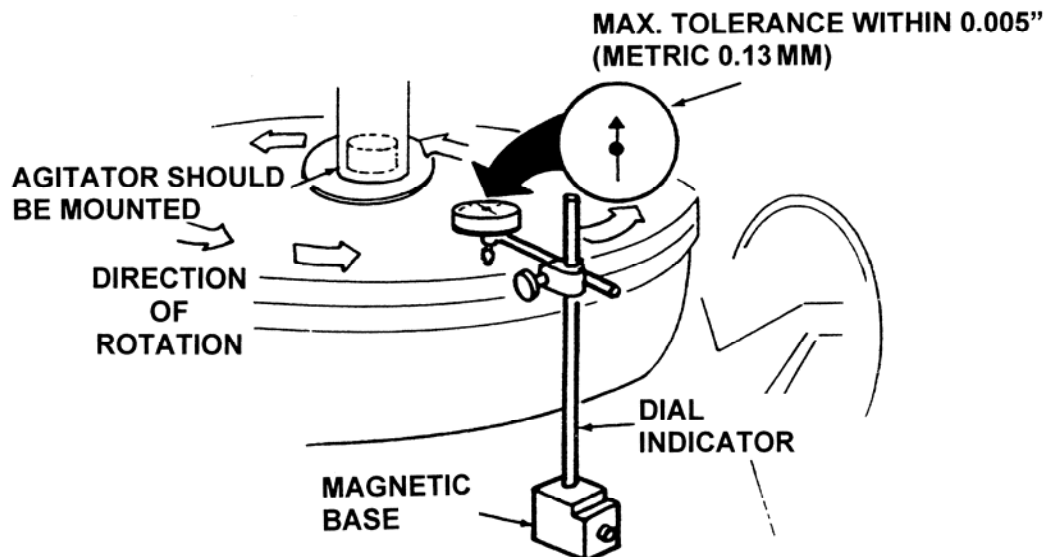

THE RUBBER SEALING PADS

The best method of reconditioning rubber pads is also done on a Blanked grinder. Some **REED** owners report that they get an acceptable reconditioning job by freezing the pad and refacing the frozen rubber on motorized wood plane. Others report they do acceptable refacing with an extremely sharp knife blade that is kept well lubricated with oil during the trimming of the high ridges of rubber. **REED** pads with imbedded bosses must be resurfaced by grinding. Mill or grind the bosses down 1/16 inches (1.5 mm) after removing the rubber required to make the face flat and smooth. The rubber face of the pad must be kept parallel to the steel back side of the pad.

RISER PLATES

Riser plates are specially manufactured and precision ground parts. No substitute should be used to raise the feed wheel assembly to its proper position. These parts are not subject to wear and consequently need not be reconditioned but they must be thoroughly cleaned prior to installing. Knicks or burrs should be removed with a file. Riser plates are only used to position the feed wheel assembly to its proper operating height.

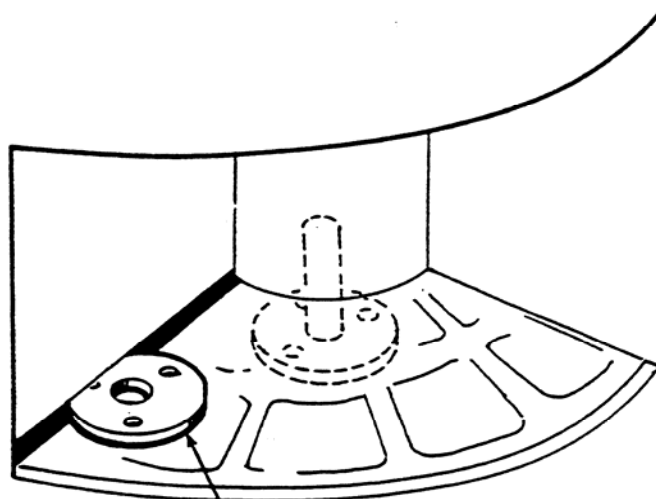

**FOR CHECKING ONLY,
IF THIN RISER PLATE SLIDE IN HERE,
RISER PLATE SHOULD BE PLACED
UNDER FEED BOWL.**

THE FEED WHEEL ASSEMBLY

After riser plates, feed bowls and wear plates are manufactured they are checked at the factory for proper tolerances. Riser plates, feed bowls and wear plates are mounted on a spindle. They are secured in place with an agitator. The assembly is rotated and checked with dial indicator as in the adjacent drawing. After reconditioning these parts it is advisable to check the final assembly in the same manner.



MODEL: LOVA
SCHEMATIC SECTION

SCHMT

PAGE 01

DIMENSIONS

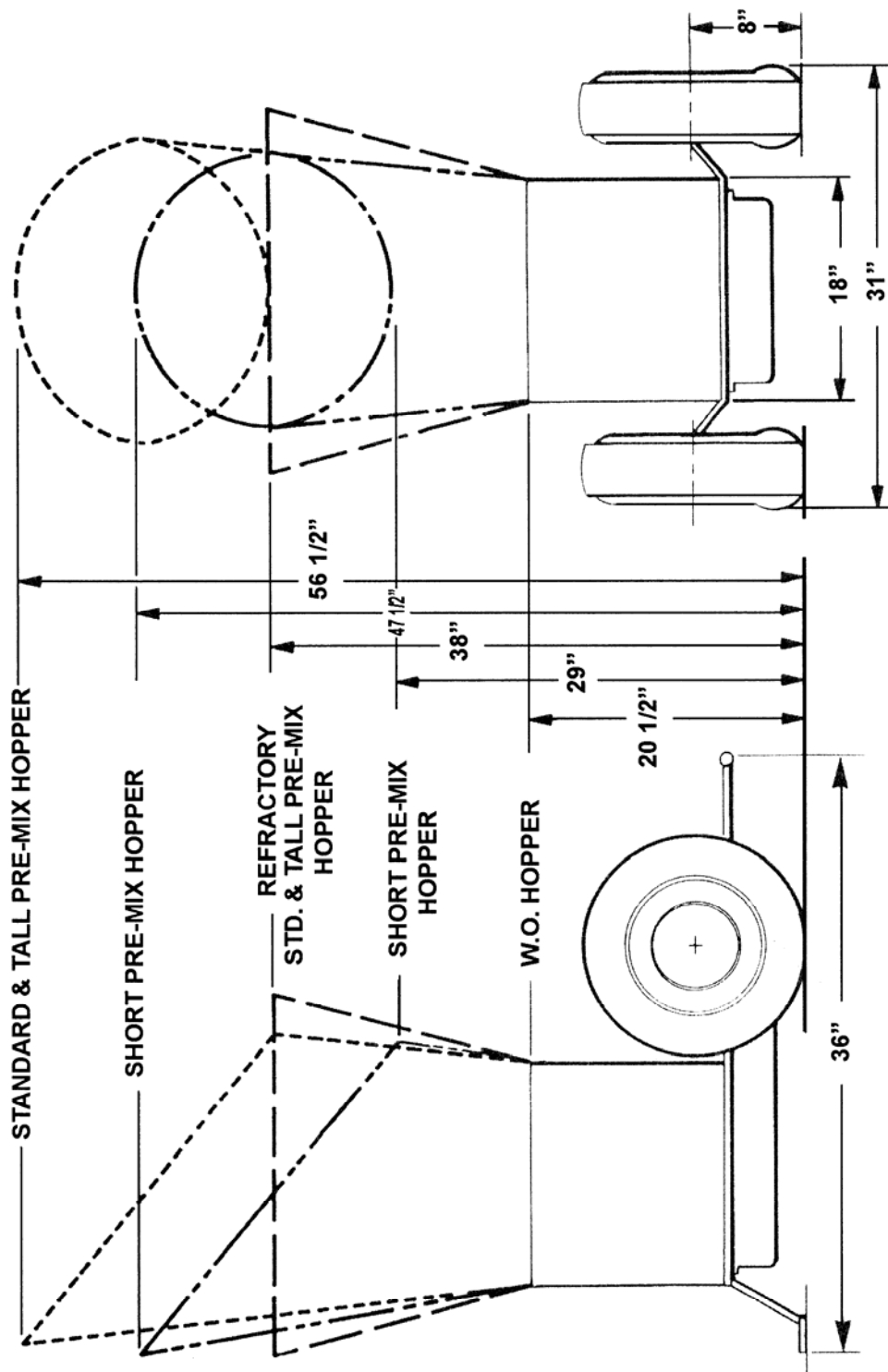

REVISION:

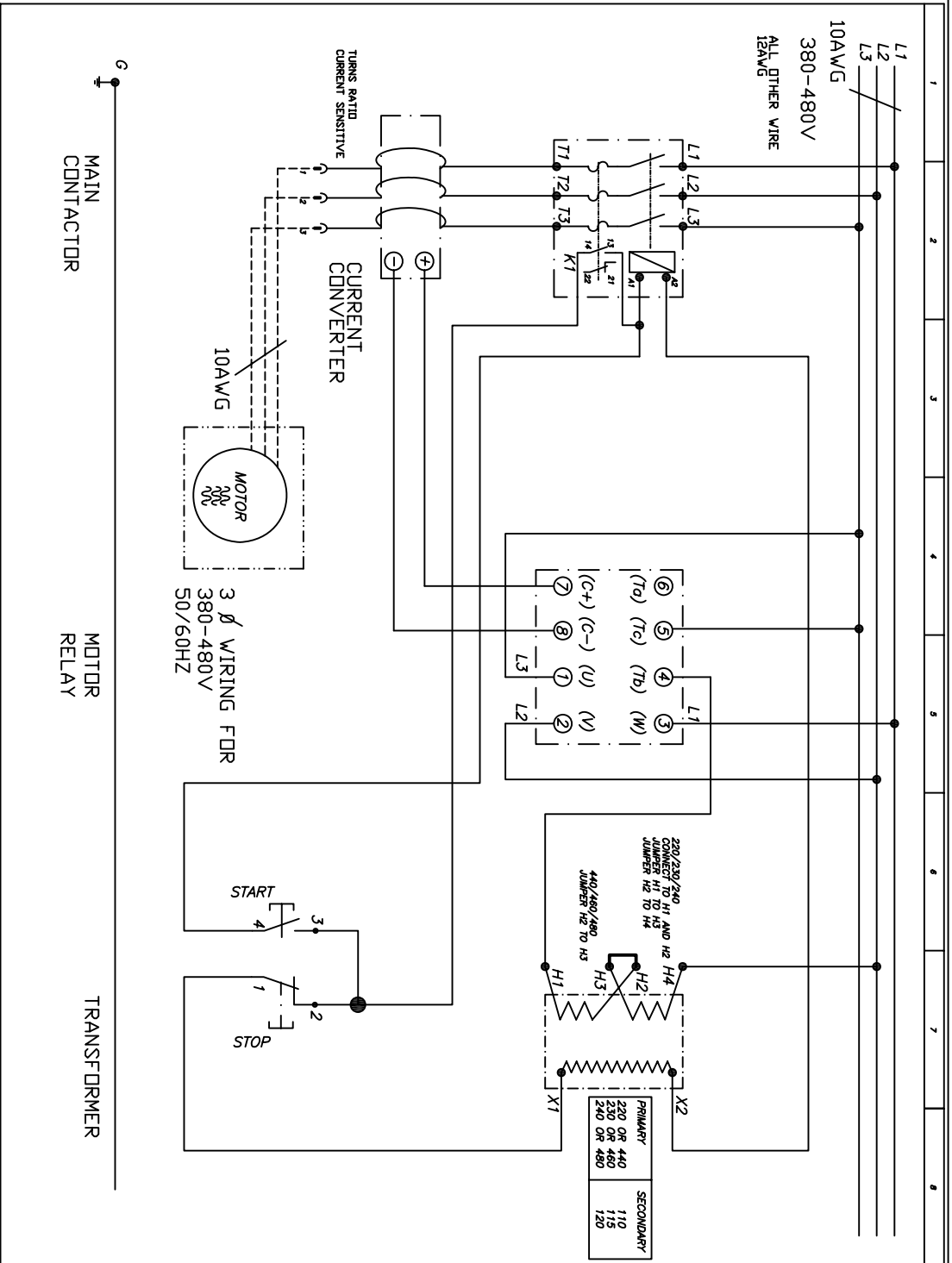

REV	DATE	DESCRIPTION OF CHANGE	BY	APPVD
A	9/27/07	ECN #1224	EY	
REVISIONS				

DD NOT SCALE DRAWING UNLESS OTHERWISE SPECIFIED, DIMENSIONS ARE IN INCHES.		TITLE WIRING DIAGRAM-380V-480V	
TOLERANCES: .XX .030 .XXX .010 FRACTION 1/32 ANGLE 1/2°		CONCRETE PLACING EQUIPMENT CHIND, CA 91710	
BREAK ALL SHARP EDGES .010 MAX. x 45		MATERIAL	
ALL MACHINED SURFACES 1/8" UNLESS OTHERWISE SPECIFIED		PART NUMBER 10174	
DRAWN DR/EY 6/25/07		REV A	
THIS DRAWING IS THE PROPERTY OF REED MANUFACTURING AND IS LOANED WITHOUT CONSIDERATION OTHER THAN THE BORROWER'S AGREEMENT THAT IT SHALL NOT BE REPRODUCED, COPIED, LOANED, OR DISPOSED OF, DIRECTLY OR INDIRECTLY, NOR USED FOR ANY PURPOSE OTHER THAN THAT FOR WHICH IT IS SPECIFICALLY FURNISHED.		SHEET 1 OF 2	

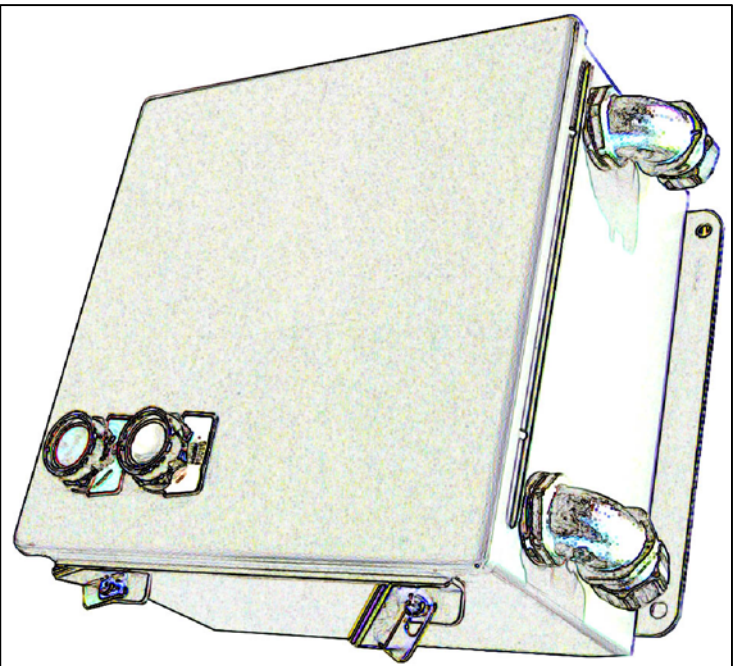

PN 10174 ELECTRICAL CONTROL BOX

REV	DATE	DESCRIPTION OF CHANGE	BY
A	9/27/07	ECN #1224	EY
REVISIONS			

DD NOT SCALE DRAWING UNLESS OTHERWISE SPECIFIED, DIMENSIONS ARE IN INCHES.	UNLESS OTHERWISE SPECIFIED, DIMENSIONS ARE IN INCHES.
TOLERANCES: .XX .030 .XXX .010 FRACTION 1/32 ANGLE 1/2°	BREAK ALL SHARP EDGES .010 MAX. x 45
ALL MACHINED SURFACES 1/64 UNLESS OTHERWISE SPECIFIED	DRAWN DR/EY 6/25/07
APPVD	

TITLE	CONCRETE PLACING EQUIPMENT
CHIND, CA 91710	
MATERIAL	CONCRETE
THIS DRAWING IS THE PROPERTY OF REED MANUFACTURING AND IS LOANED WITHOUT CONSIDERATION OTHER THAN THE BORROWER'S AGREEMENT THAT IT SHALL NOT BE REPRODUCED, COPIED, LOANED, OR DISPOSED OF, DIRECTLY OR INDIRECTLY, NOR USED FOR ANY PURPOSE OTHER THAN THAT FOR WHICH IT IS SPECIFICALLY FURNISHED.	
PART NUMBER	10174
REV	A
SHEET 2 OF 2	

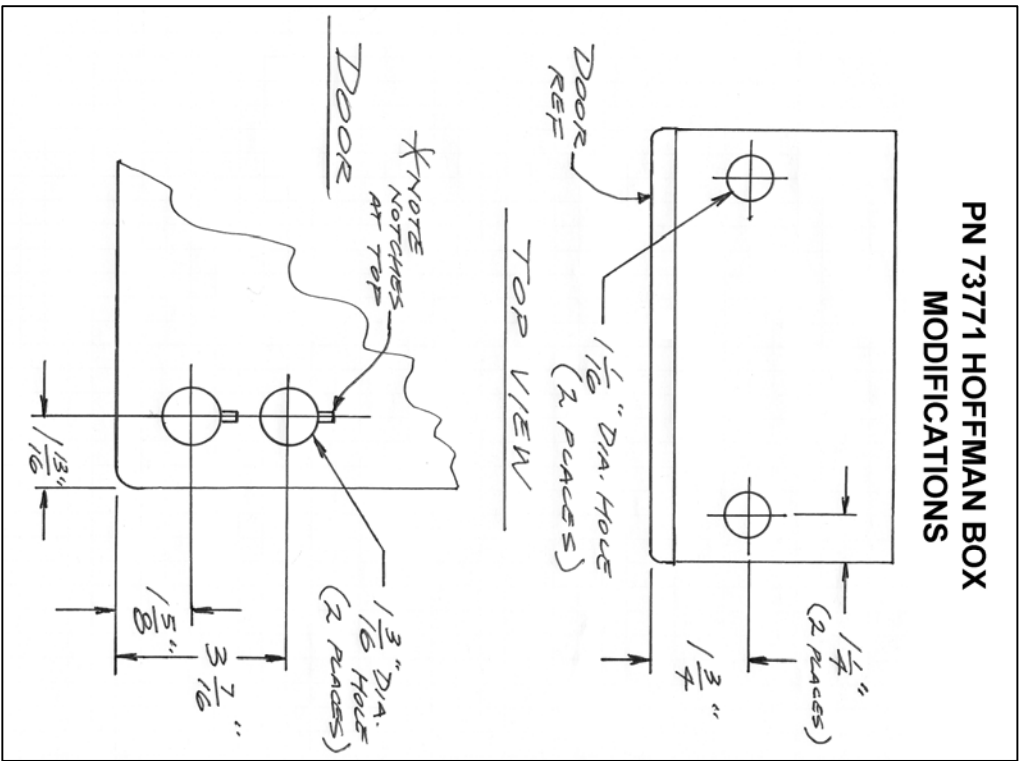

PN 73771 HOFFMAN BOX
MODIFICATIONS

NORD GEAR-ELECTRIC MOTOR CONNECTION DIAGRAMS

3-PHASE MOTOR (NEMA)

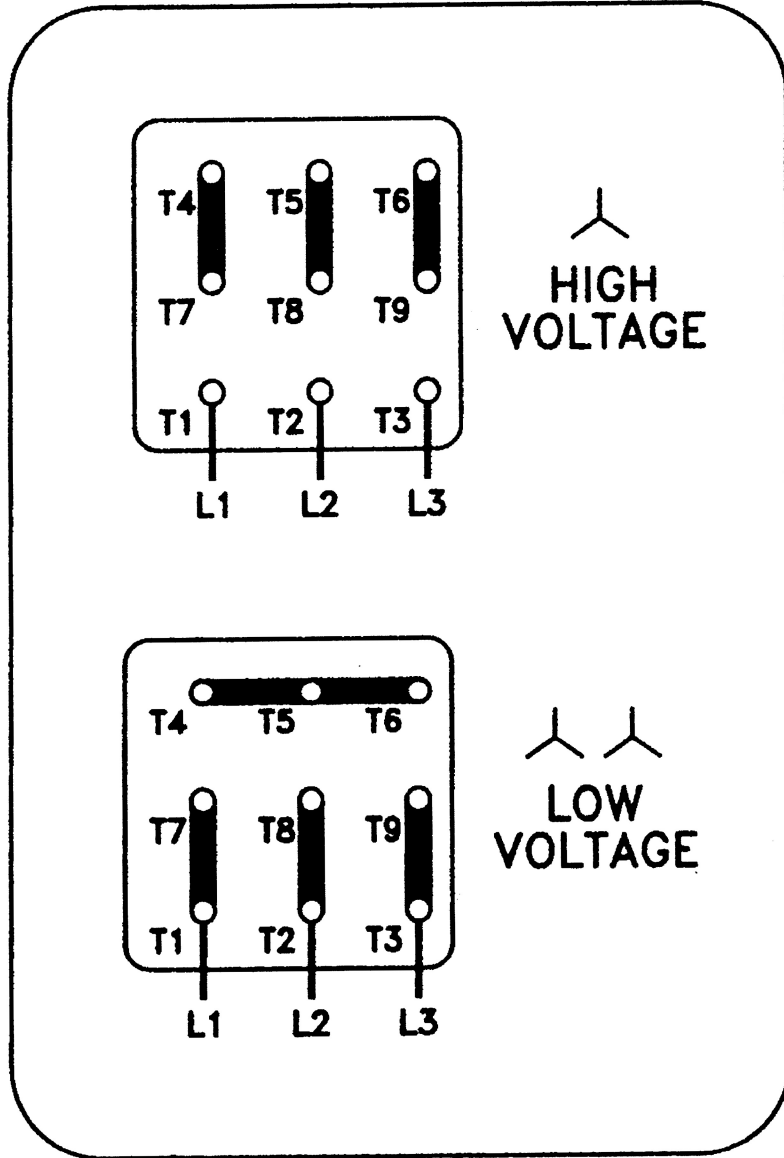

230/460V - 60 Hz

Frame 63 - 132

332/575V - 60 Hz
230/400V - 50 Hz
400/690V - 50 Hz

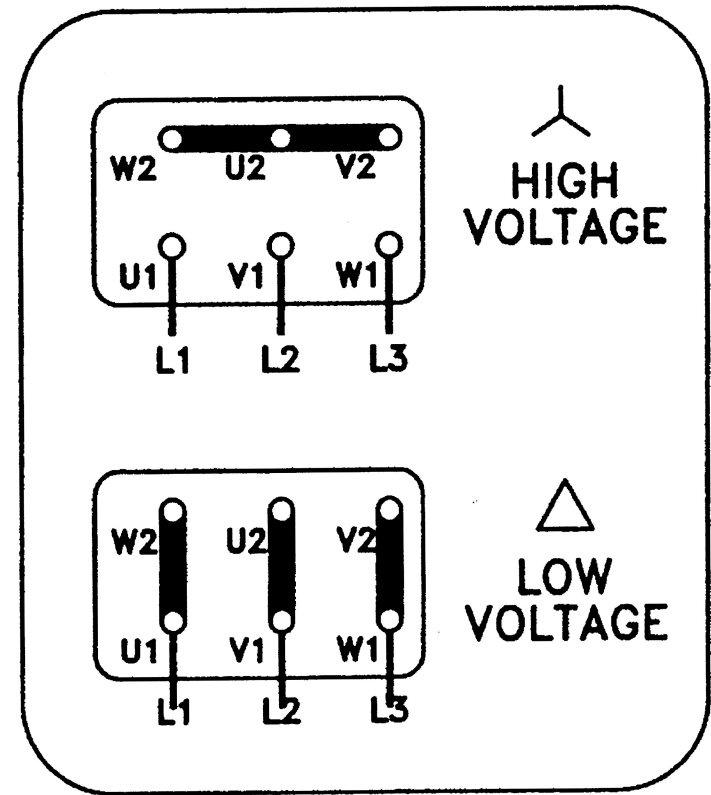

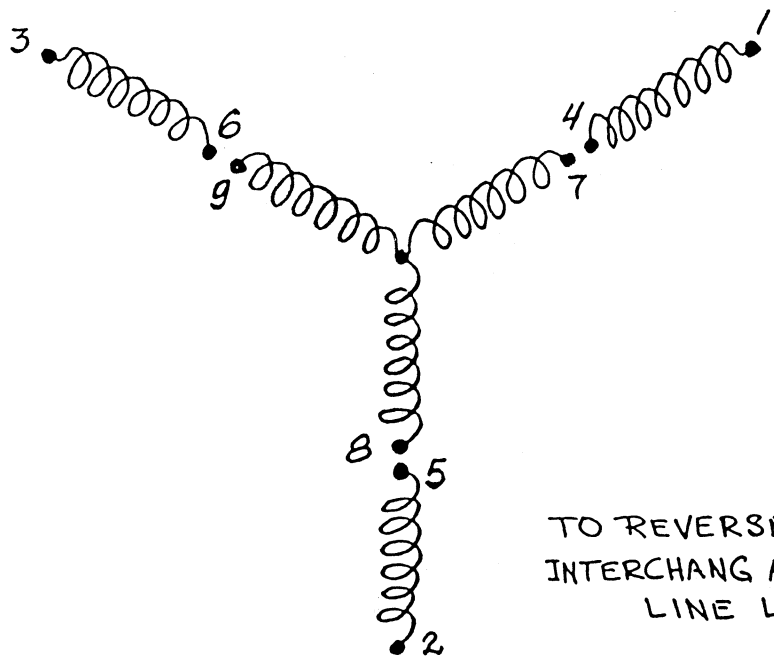

TO REVERSE ROTATION
INTERCHANG ANY TWO
LINE LEAD

9 LEADS Std. 60 CPS MOTOR

FOR	LINE			TIE LEADS	TIE LEADS	TIE LEADS
	'T ₁ ' TO	'T ₂ ' TO	'T ₃ ' TO			
LOW VOLTAGE	3 & 9	2 & 8	1 & 7	6, 5, 4	—	—
HIGH VOLTAGE	3	2	1	6, 9	5, 8	4, 7

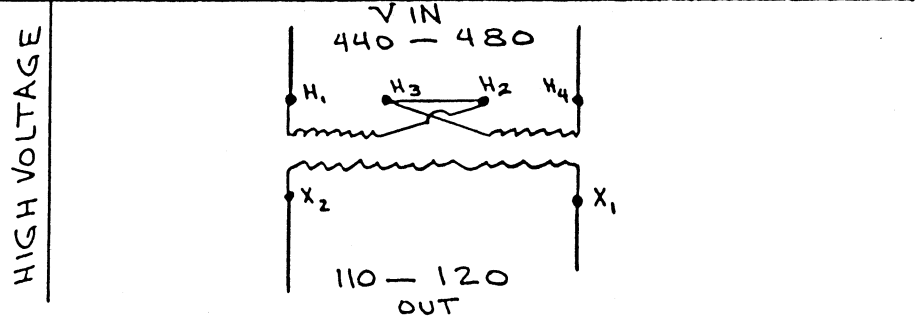
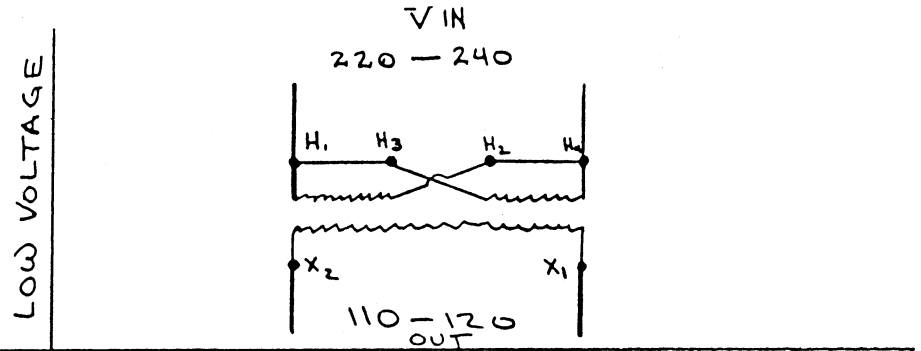
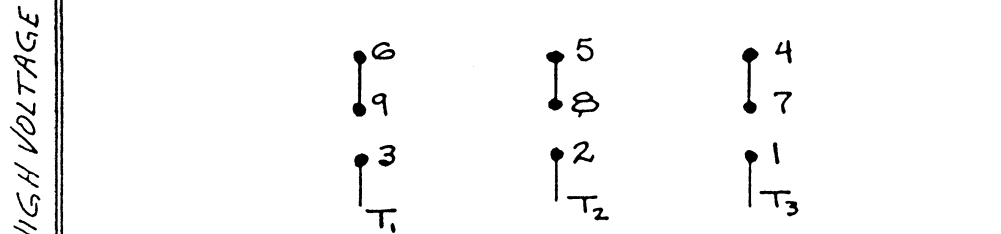
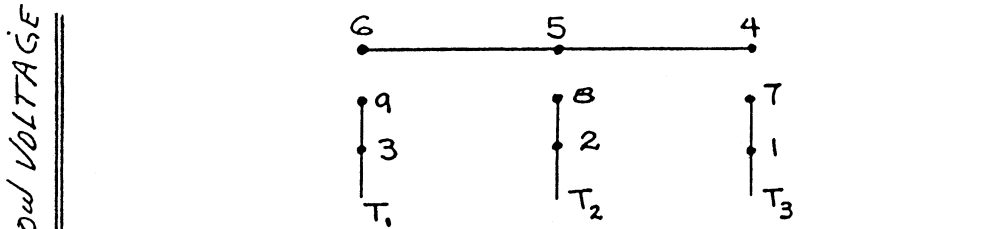

3 Φ MOTOR (1-575A) TRIPLE VOLTAGE
12 LEADS 50 CPS.

220 VOLT CONN.

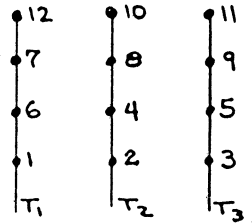

380VOLT CONN.

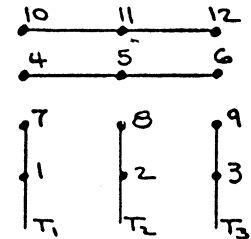

440 VOLT CONN.

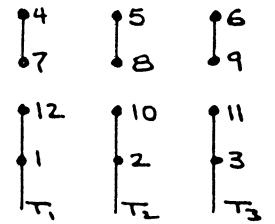

TO REVERSE ROTATION: INTERCHANGE ANY TWO LINE LEADS

**REED PNEUMATIC SPRAYING MACHINE MODEL LOVA SERIES 4
ILLUSTRATED PARTS MANUAL CONTAINS THE FOLLOWING GROUPS
AND FIGURES:**



**SHOWN MODEL: LOVA™ SERIES IV
16 AM REFRACTORY HOPPER**

**REED PNEUMATIC SPRAYING MACHINE MODEL LOVA™ SERIES 4 ILLUSTRATED
PARTS MANUAL CONTAINS THE FOLLOWING GROUPS AND FIGURES:**

GROUP 00 HOW TO USE PARTS MANUAL

- FIGURE 00** TABLE OF CONTENTS
- FIGURE 01** HOW TO USE **LOVA™** PARTS MANUAL
- FIGURE 02** HOW TO ORDER PARTS

GROUP 10 SMALL AIR MOTOR DRIVE (8 AM) INSTALLATION

- FIGURE 00** TABLE OF CONTENTS
- FIGURE 01** 8 AM STANDARD HOPPER FINAL INSTALLATION
- FIGURE 02** 8 AM TALL PREMIX HOPPER FINAL INSTALLATION
- FIGURE 03** 8 AM SHORT PREMIX HOPPER FINAL INSTALLATION
- FIGURE 04** 8 AM REFRACTORY HOPPER FINAL INSTALLATION
- FIGURE 05** SMALL AIR MOTOR DRIVE UNIT DECAL ASSEMBLY

GROUP 20 LARGE AIR MOTOR DRIVE (16 AM) INSTALLATION

- FIGURE 00** TABLE OF CONTENTS
- FIGURE 01** 16 AM STANDARD HOPPER FINAL INSTALLATION
- FIGURE 02** 16 AM TALL PREMIX HOPPER FINAL INSTALLATION
- FIGURE 03** 16 AM SHORT PREMIX HOPPER FINAL INSTALLATION
- FIGURE 04** 16 AM REFRACTORY HOPPER FINAL INSTALLATION
- FIGURE 05** LARGE AIR MOTOR DRIVE UNIT DECAL ASSEMBLY

GROUP 30 BASE GEAR INSTALLATION

- FIGURE 00** TABLE OF CONTENTS
- FIGURE 01** BASE GEAR INSTALLATION
- FIGURE 02** BASE GEAR ASSEMBLY
- FIGURE 03** DRIVE SPINDLE ASSEMBLY

GROUP 40 HOPPER AND PAD INSTALLATION

- FIGURE 00** TABLE OF CONTENTS
- FIGURE 01** STANDARD HOPPER AND PAD INSTALLATION
- FIGURE 02** TALL PREMIX HOPPER AND PAD INSTALLATION
- FIGURE 03** SHORT PREMIX HOPPER AND PAD INSTALLATION
- FIGURE 04** REFRACTORY HOPPER AND PAD INSTALLATION
- FIGURE 05** FEED WHEEL PAD HOUSING INSTALLATION
- FIGURE 06** PAD HOUSING ASSEMBLY
- FIGURE 07** KNOB GUIDE ASSEMBLY
- FIGURE 08** PAD ADJUSTING STUD ASSEMBLY
- FIGURE 09** 12 POCKET WITH DIVIDER FEED WHEEL
AND PAD BACKUP INSTALLATION
- FIGURE 10** 2 INCH SOLID LARGE AGGREGATE
PAD BACKUP ASSEMBLY

GROUP 50 AIR INLET INSTALLATION

- FIGURE 00** TABLE OF CONTENTS
- FIGURE 01** 8 AM AIR INLET INSTALLATION
- FIGURE 02** 8 AM AIR INLET INSTALLATION
FOR REFRACTORY HOPPER
- FIGURE 03** 16 AM AIR INLET INSTALLATION
- FIGURE 04** 16 AM AIR INLET INSTALLATION
FOR REFRACTORY HOPPER
- FIGURE 05** 8 AM AIR MOTOR ASSEMBLY
- FIGURE 06** 16 AM AIR MOTOR ASSEMBLY
- FIGURE 07** 8 AM AIR INLET ASSEMBLY
- FIGURE 08** 8 AM AIR INLET ASSEMBLY
FOR REFRACTORY HOPPER
- FIGURE 09** 16 AM AIR INLET ASSEMBLY
- FIGURE 10** 16 AM AIR INLET ASSEMBLY
FOR REFRACTORY HOPPER

GROUP 60 ACCESSORIES INSTALLATION

- FIGURE 00** TABLE OF CONTENTS
- FIGURE 01** ACCESSORIES INSTALLATION

GROUP 70 OPTIONAL INSTALLATION

- FIGURE 00** TABLE OF CONTENTS
FIGURE 01 OPTIONAL INSTALLATION
FIGURE 02 BULK BAG ADAPTER ASSEMBLY
FIGURE 03 12 POCKET DIVIDERLESS FEED WHEEL
AND PAD BACKUP INSTALLATION
FIGURE 04 STANDARD 15 POCKET FEED WHEEL
AND PAD BACKUP INSTALLATION
FIGURE 05 15 POCKET LARGE AGGREGATE WITH DIVIDER
FEED WHEEL AND PAD BACKUP INSTALLATION
FIGURE 06 15 POCKET LARGE AGGREGATE DIVIDERLESS
FEED WHEEL AND PAD BACKUP INSTALLATION
FIGURE 07 20 POCKET FEED WHEEL
AND PAD BACKUP INSTALLATION
FIGURE 08 21 POCKET FEED WHEEL
AND PAD BACKUP INSTALLATION
FIGURE 09 30 POCKET FEED WHEEL
AND PAD BACKUP INSTALLATION
FIGURE 10 1-1/4 INCH SOLID PAD BACKUP ASSEMBLY
FIGURE 11 1-1/2 INCH SOLID PAD BACKUP ASSEMBLY
FIGURE 12 2 INCH LINER TYPE STANDARD
PAD BACKUP ASSEMBLY
FIGURE 13 2 INCH SOLID PAD BACKUP ASSEMBLY
FIGURE 14 2 INCH LINER TYPE LARGE AGGREGATE
PAD BACKUP ASSEMBLY
FIGURE 15 1-1/2 INCH SOLID LARGE AGGREGATE
PAD BACKUP ASSEMBLY
FIGURE 16 1-1/2 INCH LINER TYPE STANDARD
PAD BACKUP ASSEMBLY
FIGURE 17 1-1/2 INCH LINER TYPE LARGE AGGREGATE
PAD BACKUP ASSEMBLY
FIGURE 18 2 INCH LINER TYPE LARGE AGGREGATE,
1-1/4 AIR INLET PAD BACKUP ASSEMBLY



**MODEL LOVA PNEUMATIC SPRAYING MACHINE
HOW TO USE PART MANUAL**

**LOVA
PARTS
GROUP 00
FIGURE 01
PAGE 01**

I. PURPOSE

This parts manual is prepared, issued and / or revised by **REED**, for the exclusive use of its customers and is intended for use in provisioning, requisitioning, storing and issuing replaceable **REED PNEUMATIC SPRAYING MACHINE MODEL LOVA™ SERIES 4**.

The contents are proprietary to **REED** and are subject to change without notice. The use of any part of this document by any other person or persons or for any other purpose without the written consent of **REED** is expressly prohibited. In addition, **REED** expressly disclaims any and all responsibility arising in or any way related to such **REED'S** prior written consent thereto.

The parts number content of this document, arrangement and breakdown sequence of items is compatible with Military Standard (**MS**) and Air Transport Association Specification (**ATA**).

II. GENERAL SYSTEM OF ASSEMBLY ORDER - Detailed Parts List (Refer to Next Page)

1. This area refers to the corresponding illustration

MODEL - GROUP - FIGURE - PAGE

A. **MODEL** shows which is **REED'S** model number.

B. **GROUP** should be divided with:

00	MODEL LOVA™ ILLUSTRATED PARTS MANUAL
10	SMALL AIR MOTOR DRIVE (8 AM) INSTALLATION
20	LARGE AIR MOTOR DRIVE (16 AM) INSTALLATION
30	BASE GEAR INSTALLATION
40	HOPPER AND PAD INSTALLATION
50	AIR INLET AND VALVE INSTALLATION
60	ACCESSORIES INSTALLATION
70	OPTIONAL INSTALLATION

C. **FIGURE** belongs to the group. Please see page of contents and each group.

D. **PAGE** numbers follow to the right of each figure number.

2. The **ITEM NUMBER** corresponds to the item number shown for the part in illustration. Parts with item number proceeded by a dash (such as: -1, -5, -12 etc.) are not illustrated.
3. **PARTS NUMBERS** that carry a **REED** part number.



MODEL LOVA PNEUMATIC SPRAYING MACHINE HOW TO USE PART MANUAL

LOVA
PARTS
GROUP 00
FIGURE 01
PAGE 03

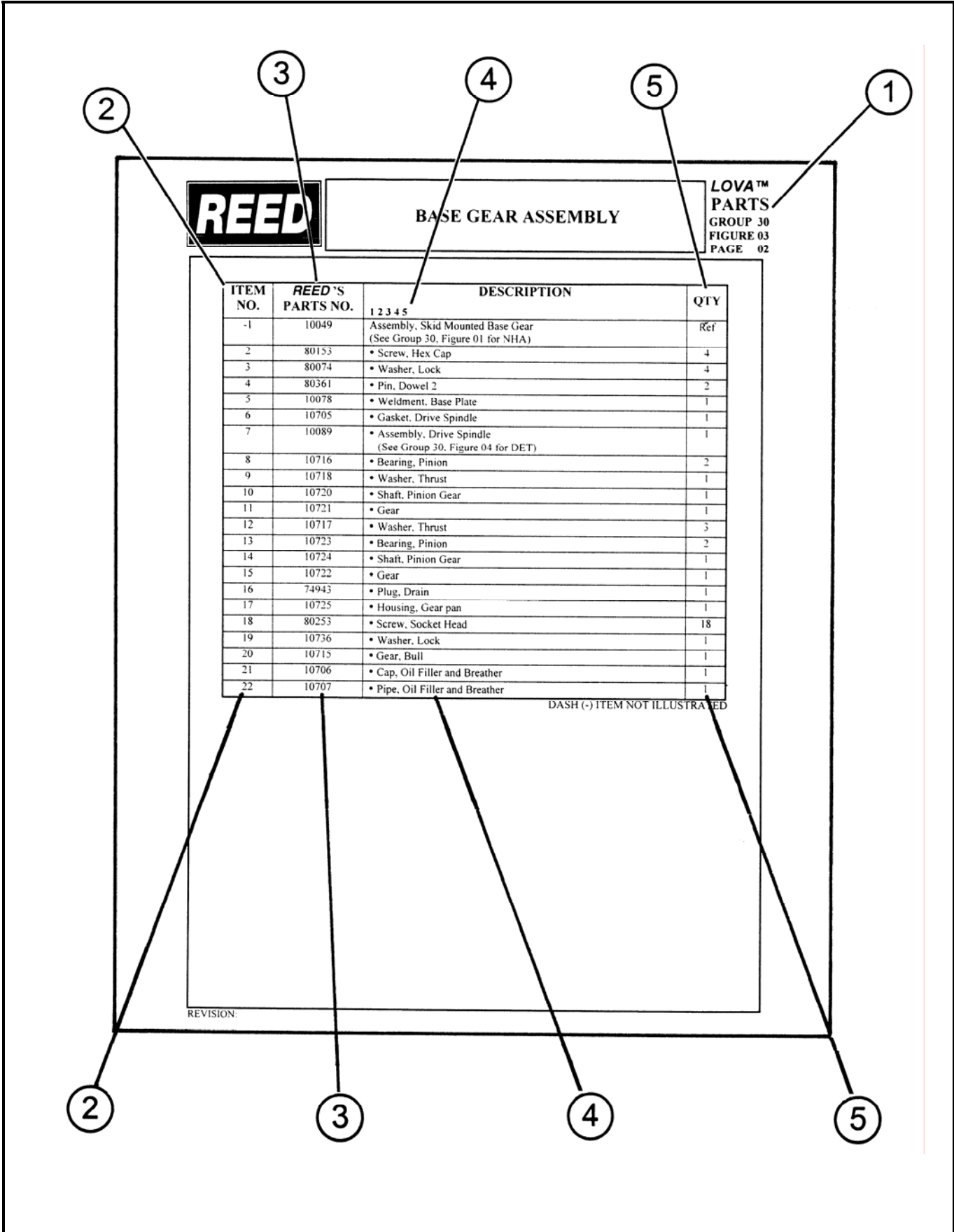

REVISION:



**MODEL LOVA PNEUMATIC SPRAYING MACHINE
HOW TO ORDER PARTS**

**LOVA
PARTS**
GROUP 00
FIGURE 01
PAGE 03



BASE GEAR ASSEMBLY

**LOVA™
PARTS**
GROUP 30
FIGURE 03
PAGE 02

ITEM NO.	REED'S PARTS NO.	DESCRIPTION	QTY
		1 2 3 4 5	
-1	10049	Assembly, Skid Mounted Base Gear (See Group 30, Figure 01 for NHA)	Ref
2	80153	* Screw, Hex Cap	4
3	80074	* Washer, Lock	4
4	80361	* Pin, Dowel 2	2
5	10078	* Weldment, Base Plate	1
6	10705	* Gasket, Drive Spindle	1
7	10089	* Assembly, Drive Spindle (See Group 30, Figure 04 for DET)	1
8	10716	* Bearing, Pinion	2
9	10718	* Washer, Thrust	1
10	10720	* Shaft, Pinion Gear	1
11	10721	* Gear	1
12	10717	* Washer, Thrust	3
13	10723	* Bearing, Pinion	2
14	10724	* Shaft, Pinion Gear	1
15	10722	* Gear	1
16	74943	* Plug, Drain	1
17	10725	* Housing, Gear pan	1
18	80253	* Screw, Socket Head	18
19	10736	* Washer, Lock	1
20	10715	* Gear, Bull	1
21	10706	* Cap, Oil Filler and Breather	1
22	10707	* Pipe, Oil Filler and Breather	1

DASH (-) ITEM NOT ILLUSTRATED

REVISION:

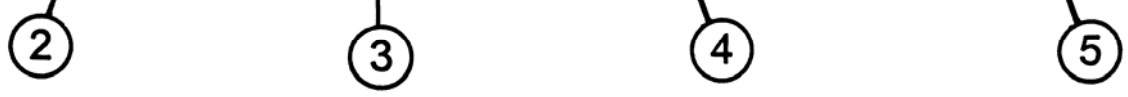

REVISION:



MODEL LOVA PNEUMATIC SPRAYING MACHINE
HOW TO ORDER PARTS

LOVA
PARTS
GROUP 00
FIGURE 01
PAGE 04

4. DESCRIPTION

A. The **INDENTURE SYSTEM** used in the parts list shows the relationship of one part to another. For a given item, the number of indentures depicts the relationship of the item to the components of the item as follows:

- 1 2 3 4 5**
Assembly (or Installation)
- **Detail part of assembly**
 - **Sub-assembly**
 - **Attaching parts for sub-assembly**
 - ● **Detail part of sub-assembly**
 - ● **Sub-sub-assembly**
 - ● **Attaching parts for sub-sub-assembly**
 - ● ● **Detail part of sub-sub-assembly**
 - ● ● **Sub-sub-sub-assembly**
 - ● ● **Attaching parts of sub-sub-sub-assembly**
 - ● ● ● **Detail part of sub-sub-sub-assembly**

- B. “See Group 20, Figure 01 For **NHA**”
Identifies the illustrated parts chapter location; indicates where the Next Higher Assembly (**NHA**) of the item shown.
- C. “See Group 60, Figure 07 For **DET**”
Identifies the illustrated parts chapter location; indicates where the item and its Detailed Breakdown (**DET**) is shown.
- D. “See Group 30, Figure 05 for **REF**” or “See Vendor Chapter for **REF**”
Identifies the illustrated parts chapter where the part is, and if listed and illustrated in Vendor Chapter. It is used as a cross-reference (**REF**).

5. QUANTITY

- A. Reference (**REF**) indicates the items that is listed previously in the Next Higher Assembly (**NHA**) and then again in this figure.
- B. As Required (**A/R**) indicates the parts that is used in a quantity as required.
- C. A number entry indicates the quantity of the part used in its next higher application.
6. Functionally related assemblies are illustrated in phantom(_____) but not listed on the detail parts list page.

REVISION:



**MODEL LOVA PNEUMATIC SPRAYING MACHINE
HOW TO ORDER PARTS**

1. Always give serial number of *PNEUMATIC SPRAYING MACHINE MODEL LOVA™ SERIES 4* (Refer to each unit nameplate shown below). NOTE: This manual is being released to cover unit starting with serial number **98-3787-8-4R** to current production. Some components used on earlier units differ from current productions. Where this occurs, the part is identified by a serial number.

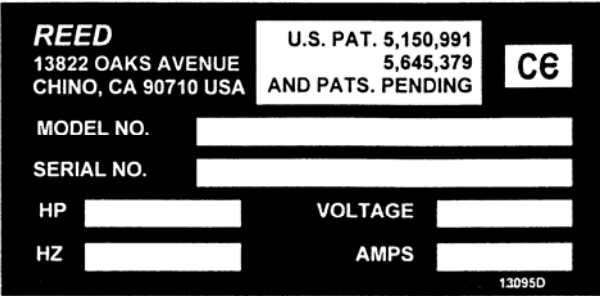

2. Always specify part number and complete name of parts ordered.

A. Turn to table of content in the desired Installation.
Refer to main group in which part should be listed.

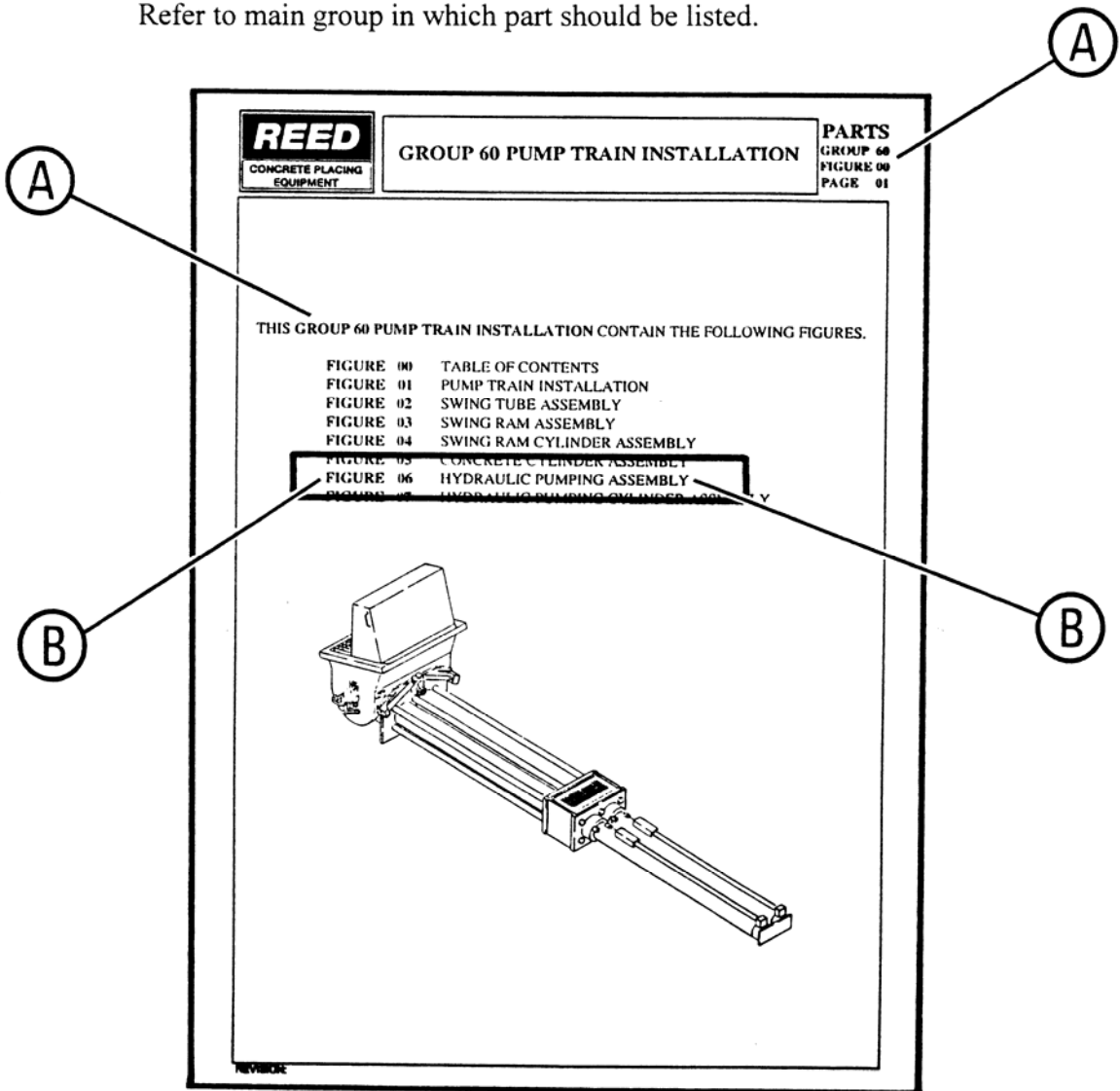



MODEL LOVA PNEUMATIC SPRAYING MACHINE HOW TO USE PART MANUAL

LOVA
PARTS
GROUP 00
FIGURE 02
PAGE 02

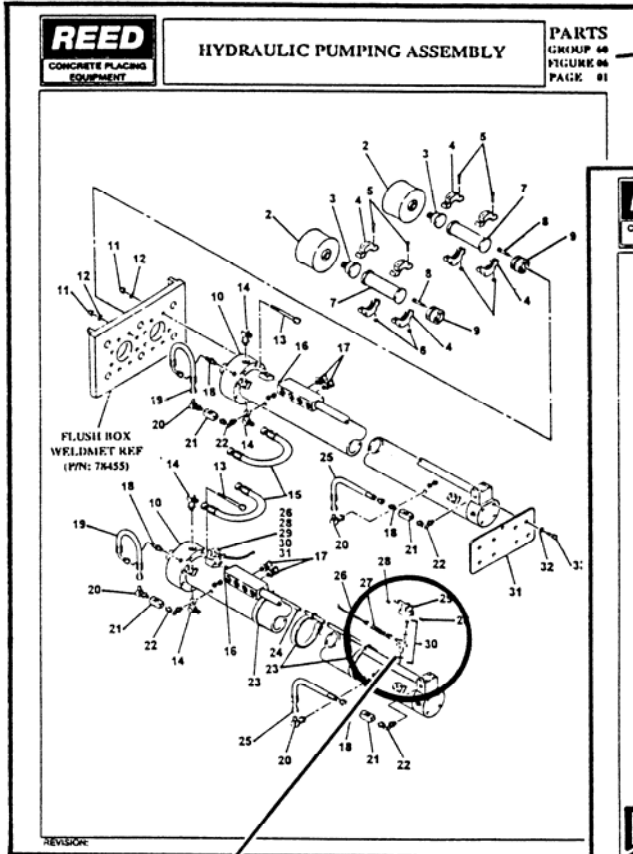

REED
CONCRETE PLACING EQUIPMENT

HYDRAULIC PUMPING ASSEMBLY

PARTS GROUP 00
FIGURE 02
PAGE 01

ITEM NO.	REED'S PARTS NO.	DESCRIPTION	QTY
1	78436	Assembly, Hydraulic Pumping (See Group 20, Figure 1 for NHA)	1
2	78354	* Cup, Piston	2
3	78444	* Coupler	2
4	78352	* Coupling, Drive	4
5		* Bolt 1/2 x 4 (attaching parts)	8
6		* Nut, 1/2 (attaching parts)	8
7	78441	* Hose, 1/2"	2
8		* Bolt 5/8 x 2	6
9	78442	* Coupler	2
10	78438	Assembly, Hydraulic Cylinder (See Group 20, Figure 07 for DET)	1
11		* Nut (attaching parts)	16
12		* Washer (attaching parts)	16
13	77617	* Bolt (attaching parts)	16
14		* Elbow, 90° F56802-16-16	4
15	79343	* Assy, Hose	2
16	78591	* Filter, Alarm Check (P/N)	2
17		* Elbow, 90° F56802-06-06	4
18		* Filter, STD F56803-06-06	4
19	79344	* Assy, Hose	2
20		* Elbow, 90° F56803-06-06	4
21		* Elbow, Check	4
22		* Elbow, 90° M18M19K16-16	4
23		* Clamp	3
24	79326	* Tube, Wire	1
25	79345	* Assembly, Tube	2
26	78417	* Cable	2
27	72010	* Locks, 1/2 Flx	A/R
28		* Pin, 1/4 x 20	4
29	78453	* Control, Proximity Switch	2
30	78416	* Switch, Proximity	2
31	78455	* Flush Box	1
32		* Washer, 1 Lock (attaching parts)	8
33		* Bolt, 1 x 2 Course (attaching parts)	8

REVISION:

- B. Find title of figure in which the part should be shown. Note figure number.
- C. Turn to corresponding page, find the group and figure.
- D. Check your required part and its attaching parts and matches with illustration page.
- E. Refer to corresponding item number in the part list page.
Part numbers are located in the part number column.
- F. When ordering variable or optional miscellaneous parts which are not found this in parts chapter, follow the above outlined procedure of how to order parts.
 - 1). When applicable, give model and serial number of the component for which parts are desired.
 - 2). In a specific, difficult to describe situation, a marked-up photograph or detailed sketch would be helpful.



MODEL *LOVA* PNEUMATIC SPRAYING MACHINE
HOW TO USE PART MANUAL

LOVA
PARTS
GROUP 00
FIGURE 03
PAGE 01

3. Do not designate quantity by "set". State specifically how many parts are wanted.
4. Always give complete address and full shipping instructions. Specify shipping instructions, truck freight, air freight. United Parcel Service (UPS), or FedEx and DHL are available in designated areas.

5. TO ORDER

A. BY MAIL

Attention: Parts Department
REED
13822 Oaks Avenue
Chino, CA. 91710

B. BY FAX

(909) 287 - 2141

C. BY PHONE

(909) 287 - 2100

6. Parts return without authorization will not be accepted. If it is necessary to return parts for any reason, written authorization may be obtained from **REED** Parts Department, Chino, CA. 91710. A Parts Return Authorization form is provided when **REED** deems its necessary to have the part returned for evaluation. The form is issued by the Warranty of Parts Department of **REED**.
 - A. The form will be filled by **REED** unless requesting necessary information and you will receive a copy as well as shipping tag.
 - B. Attach shipping tag to part insert return original invoice.
 - C. Ship part to **REED PREPAID**.
 - D. Part must be returned to **REED** within 30 days from date of authorization.

REED PNEUMATIC SPRAYING MACHINE MODEL LOVA™ SERIES 4 ILLUSTRATED PARTS MANUAL GROUP 10 SMALL AIR MOTOR DRIVE (8 AM) INSTALLATION CONTAINS THE FOLLOWING FIGURES:

- FIGURE 00** TABLE OF CONTENTS
- FIGURE 01** 8 AM STANDARD HOPPER FINAL INSTALLATION
- FIGURE 02** 8 AM TALL PREMIX HOPPER FINAL INSTALLATION
- FIGURE 03** 8 AM SHORT PREMIX HOPPER FINAL INSTALLATION
- FIGURE 04** 8 AM REFRACTORY HOPPER FINAL INSTALLATION
- FIGURE 05** SMALL AIR MOTOR DRIVE UNIT DECAL ASSEMBLY

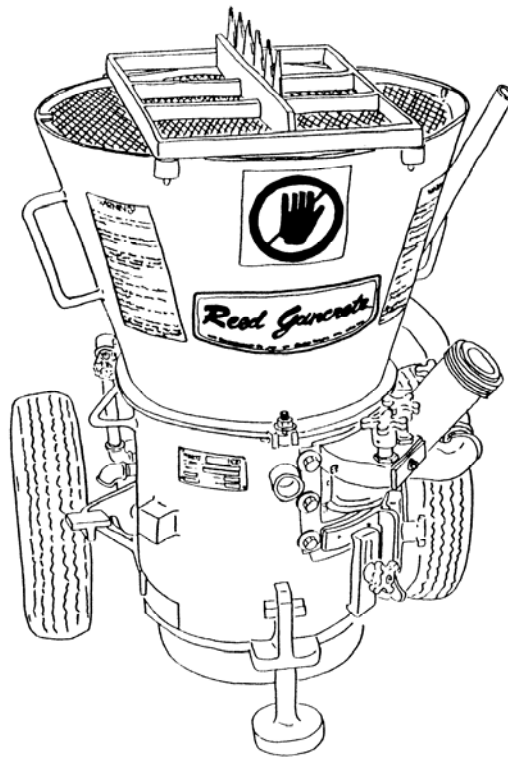

**SHOWN MODEL: LOVA™ SERIES 4
8 AM SHORT PREMIX HOPPER**



SMALL AIR MOTOR DRIVE (8AM)
STANDARD HOPPER
FINAL INSTALLATION

LOVA
PARTS
GROUP 10
FIGURE 01
PAGE 01

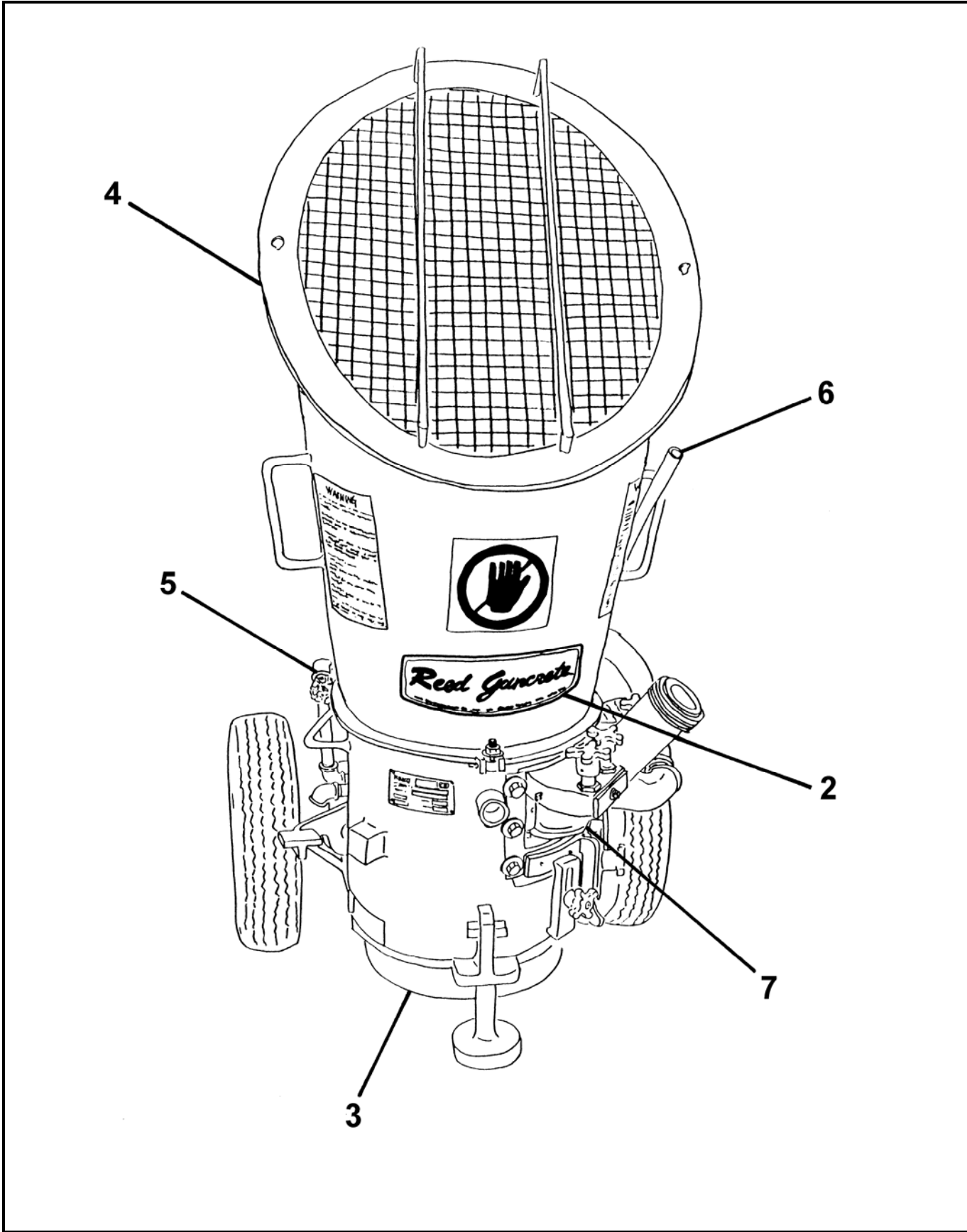

REVISION:



SMALL AIR MOTOR DRIVE (8AM)
STANDARD HOPPER
FINAL INSTALLATION

LOVA
PARTS
GROUP 10
FIGURE 01
PAGE 02

ITEM NO.	REED'S PARTS NO.	DESCRIPTION	QTY
		1 2 3 4 5	
-1	1001	Installation, Small Air Motor Drive (8 Am) Standard Hopper Final	Ref
2	10-05	• Assembly, Small Air Motor Drive (8 Am) Unit Decal (See Group 10, Figure 05 for DET)	1
3	30-01	• Installation, Base (See Group 30, Figure 01 for DET)	1
4	40-01	• Installation, Standard Hopper and Pad (See Group 40, Figure 01 for DET)	1
5	50-01	• Installation, 8 Am Air Inlet (See Group 50, Figure 01 for DET)	1
6	60-01	• Installation, Accessories (See Group 60, Figure 01 for DET)	1
7	70-01	• Installation, Optional (See Group 70, Figure 01 for DET)	1

DASH (-) ITEM NOT ILLUSTRATED

REVISION:



SMALL AIR MOTOR DRIVE (8AM)
TALL PREMIX HOPPER
FINAL INSTALLATION

LOVA
PARTS
GROUP 10
FIGURE 02
PAGE 01

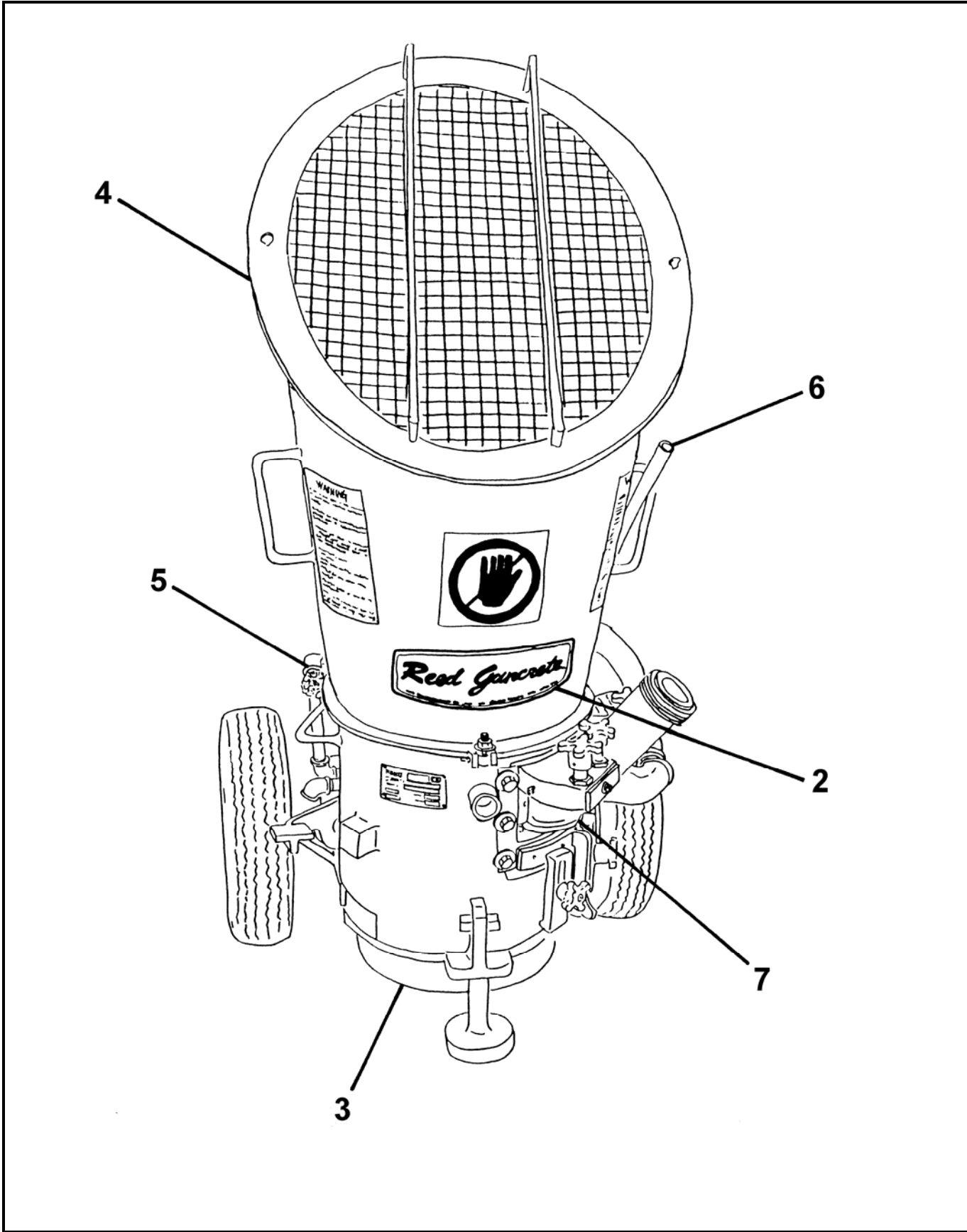

REVISION:



SMALL AIR MOTOR DRIVE (8AM)
TALL PREMIX HOPPER
FINAL INSTALLATION

LOVA
PARTS
GROUP 10
FIGURE 02
PAGE 02

ITEM NO.	REED'S PARTS NO.	DESCRIPTION	QTY
		1 2 3 4 5	
-1	1015	Installation, Small Air Motor Drive (8 Am) Tall Premix Hopper Final	Ref
2	10-05	• Assembly, Small Air Motor Drive (8 Am) Unit Decal (See Group 10, Figure 05 for DET)	1
3	30-01	• Installation, Base (See Group 30, Figure 01 for DET)	1
4	40-02	• Installation, Premix Hopper and Pad (See Group 40, Figure 02 for DET)	1
5	50-01	• Installation, 8 Am Air Inlet (See Group 50, Figure 01 for DET)	1
6	60-01	• Installation, Accessories (See Group 60, Figure 01 for DET)	1
7	70-01	• Installation, Optional (See Group 70, Figure 01 for DET)	1

DASH (-) ITEM NOT ILLUSTRATED

REVISION:



SMALL AIR MOTOR DRIVE (8AM)
SHORT PREMIX HOPPER
FINAL INSTALLATION

LOVA
PARTS
GROUP 10
FIGURE 03
PAGE 01

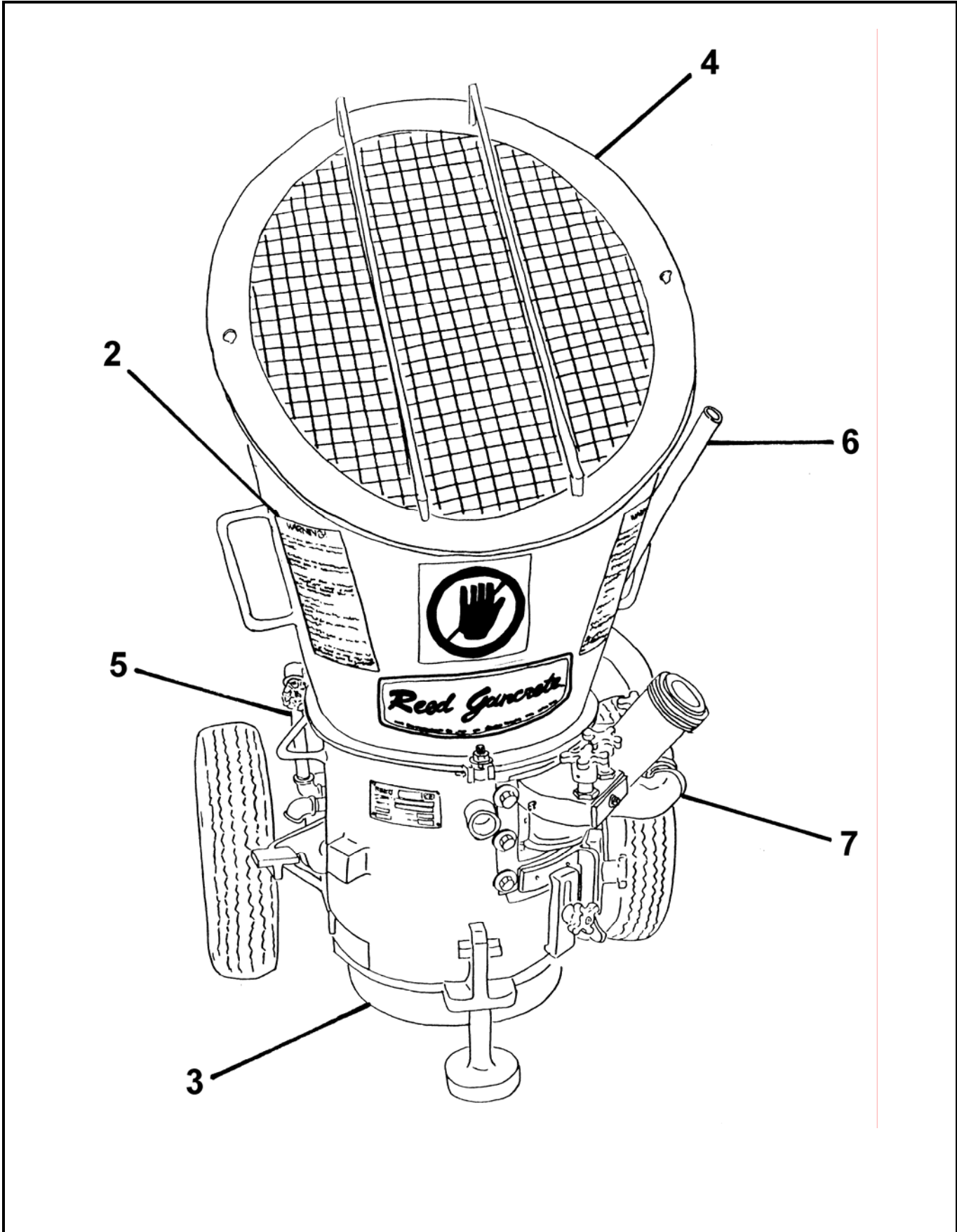

REVISION:



**SMALL AIR MOTOR DRIVE (8AM)
SHORT PREMIX HOPPER
FINAL INSTALLATION**

**LOVA
PARTS
GROUP 10
FIGURE 03
PAGE 02**

ITEM NO.	REED'S PARTS NO.	DESCRIPTION	QTY
		1 2 3 4 5	
-1	1025	Installation, Small Air Motor Drive (8 Am) Short Premix Hopper Final	Ref
2	10-05	• Assembly, Small Air Motor Drive (8 Am) Unit Decal (See Group 10, Figure 05 for DET)	1
3	30-01	• Installation, Base (See Group 30, Figure 01 for DET)	1
4	40-03	• Installation, Shor Hopper and Pad (See Group 40, Figure 03 for DET)	1
5	50-01	• Installation, 8 AM Air Inlet (See Group 50, Figure 01 for DET)	1
6	60-01	• Installation, Accessories (See Group 60, Figure 01 for DET)	1
7	70-01	• Installation, Optional (See Group 70, Figure 01 for DET)	1

DASH (-) ITEM NOT ILLUSTRATED

REVISION:



SMALL AIR MOTOR DRIVE (8AM)
REFRACTORY HOPPER
FINAL INSTALLATION

LOVA
PARTS
GROUP 10
FIGURE 04
PAGE 01

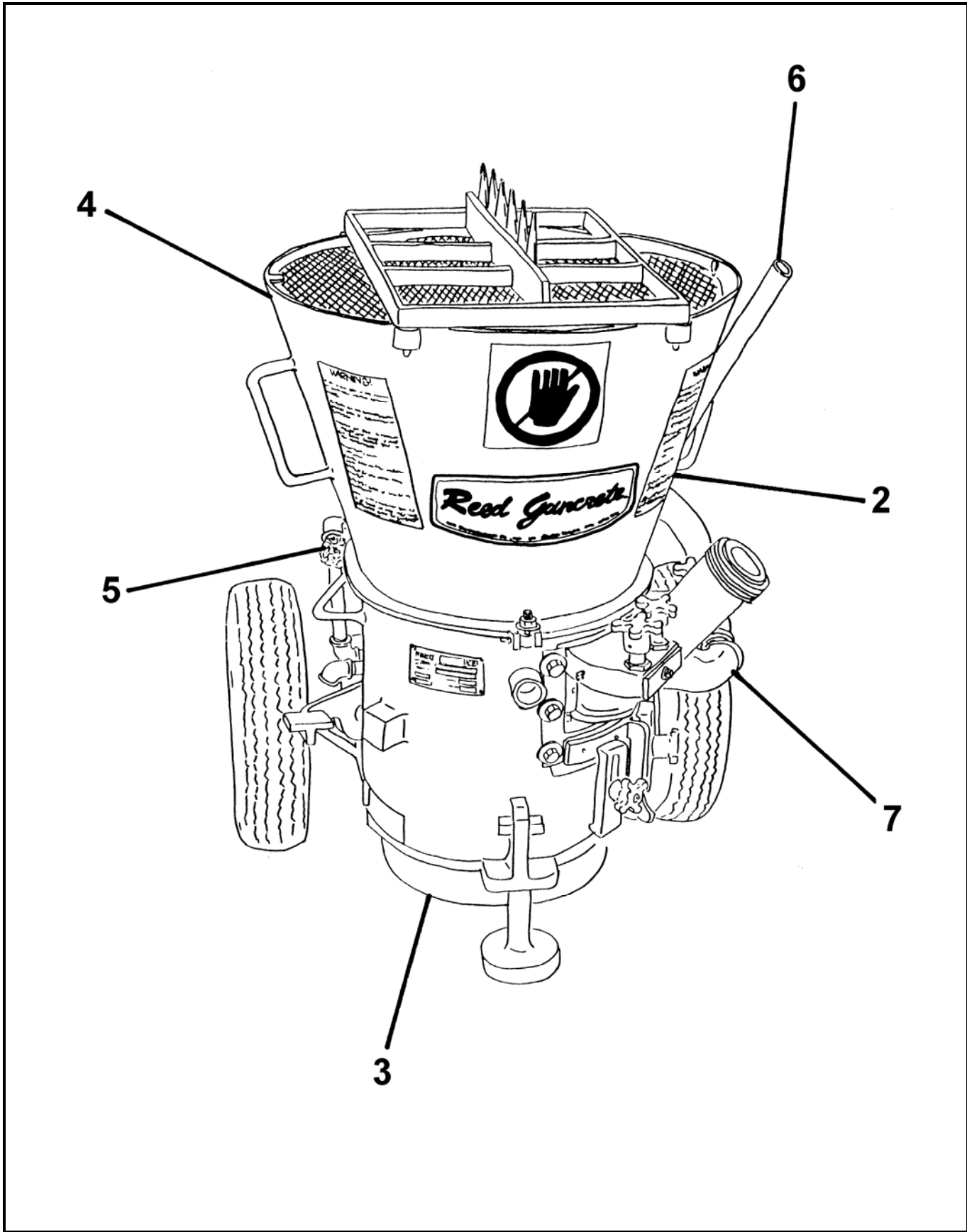

REVISION:



SMALL AIR MOTOR (8AM)
REFRACTORY HOPPER
FINAL INSTALLATION

LOVA
PARTS
GROUP 10
FIGURE 04
PAGE 02

ITEM NO.	REED'S PARTS NO.	DESCRIPTION	QTY
		1 2 3 4 5	
-1	1050	Installation, Small Air Motor Drive (8 Am) Refractory Hopper Final	Ref
2	10-05	• Assembly, Small Air Motor Drive (8 Am) Unit Decal (See Group 10, Figure 05 for DET)	1
3	30-01	• Installation, Base (See Group 30, Figure 01 for DET)	1
4	40-04	• Installation, Refractory Hopper and Pad (See Group 40, Figure 04 for DET)	1
5	50-02	• Installation, 8 Am Air Inlet for Refractory Hopper (See Group 50, Figure 02 for DET)	1
6	60-01	• Installation, Accessories (See Group 60, Figure 01 for DET)	1
7	70-01	• Installation, Optional (See Group 70, Figure 01 for DET)	1

DASH (-) ITEM NOT ILLUSTRATED

REVISION:



SMALL AIR MOTOR (8AM)
DECAL ASSEMBLY

LOVA
PARTS
GROUP 10
FIGURE 05
PAGE 01

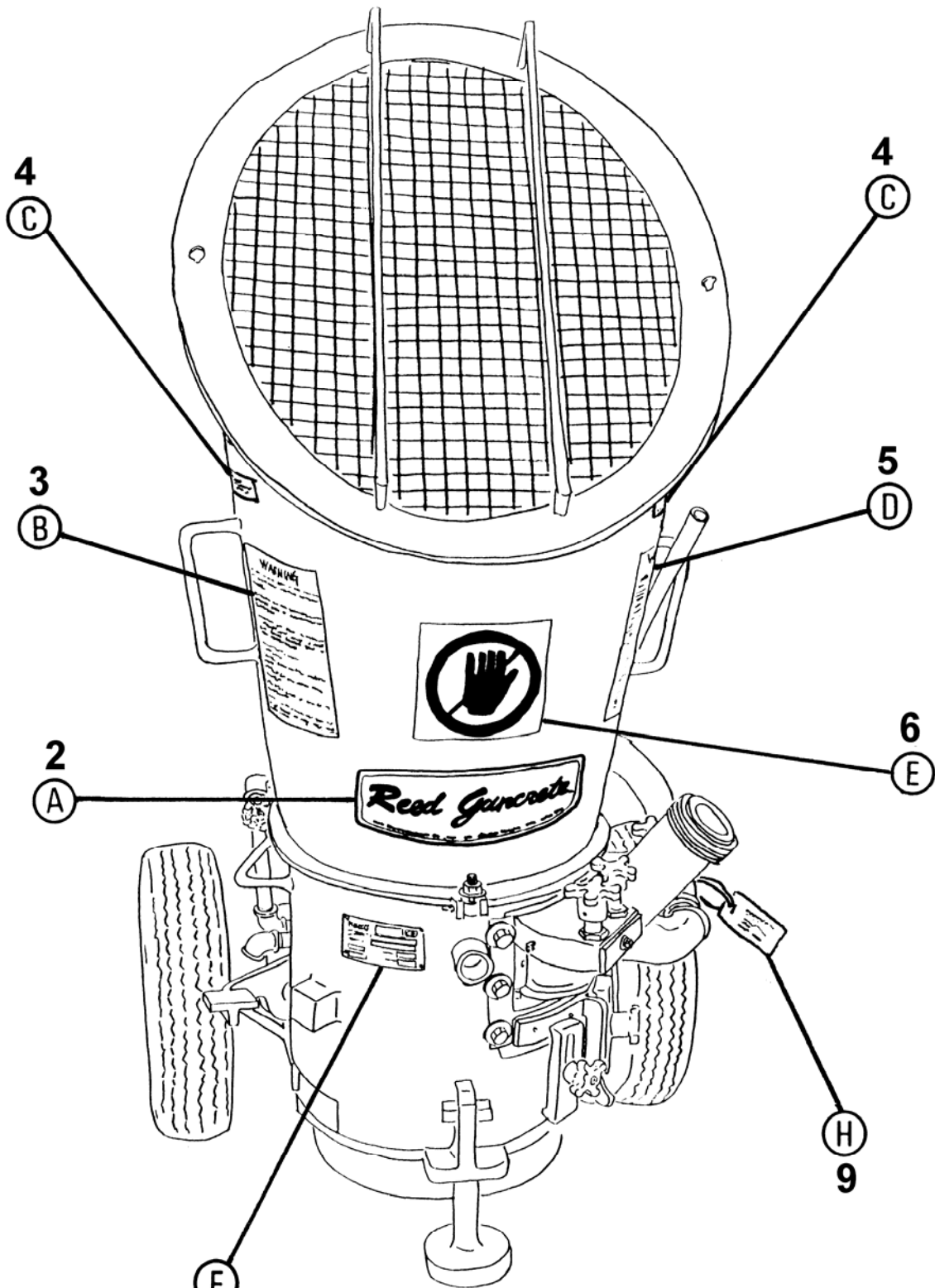

SHOWN MODEL: LOVA™ SERIES IV
8 AM STANDARD HOPPER



SMALL AIR MOTOR DRIVE (8AM)
DECAL ASSEMBLY

LOVA
PARTS
GROUP 10
FIGURE 05
PAGE 02

ITEM NO.	REED'S PARTS NO.	DESCRIPTION	QTY
		1 2 3 4 5	
-1	10-05	Assembly, Small Air Motor Drive (8 Am) Unit Decal (See Group 10, Figure 01, 02, 03 and 04 for NHA)	Ref
2	10833	• Decal, REED Guncrete	2
3	10840	• Decal, WARNING , The Inside Hopper of this Machine has	1
4	10842	• Decal, CAUTION , Do Not Lift this Machine by Hopper Handle	2
5	10839	• Decal, WARNING , The Wear Pad Area of this Machine is	1
6	75005	• Decal, DANGER , Do not Put Your Hands	2
7	13095	• Nameplate, Guns Serial Number	1
-8	10838	• Decal, WARNING , Safety Glasses	1
9	13274	• Tag, Excessive Bowl RPM May Create Premature Pad Wear and	1
-10	13273	• Tag, Machine Operator Must Set Oil Lubricator Flow,	1
-11		• Ty-Rap	2

DASH (-) ITEM NOT ILLUSTRATED



(A)

2

WARNING!

The inside of the hopper of this machine has moving parts which are extremely dangerous.

It is essential that strict safety procedures be followed before any work is done inside the hopper.

The screen on the hopper is bolted in a closed position to restrict access. If maintenance must be performed inside the hopper, proceed as follows:

- (1) Shut off power source.
air / electric
- (2) Disconnect air feed line or electrical cord.
- (3) Remove bolts securing the hopper screen.

Work inside the hopper may now be performed safely.

Upon completion of the work, replace the bolts and secure the hopper screen in a closed position. Reconnect air feed line or electrical cord and restore power.

(B)

3



SMALL AIR MOTOR (8AM)
DECAL ASSEMBLY

LOVA
PARTS
GROUP 10
FIGURE 05
PAGE 04

CAUTION DO NOT LIFT
THIS MACHINE BY HOPPER HANDLES.
USE SLINGS UNDER MACHINE.

4



WARNING!

The wear pad area of this machine is extremely dangerous when the wear pad and pad back-up assembly are removed.

It is essential that strict safety procedures be followed before performing any work in the wear pad area.

If maintenance must be performed in this area then proceed as follows:

- (1) Shut off power.
air / electric
- (2) Disconnect air feed line or electric cord.

5



Work in the wear pad area can now be performed safely.

Upon completion of this work, reconnect air feed line or electrical cord, and restore power.



SMALL AIR MOTOR (8AM)
DECAL ASSEMBLY

LOVA
PARTS
GROUP 10
FIGURE 05
PAGE 05



6

(E)

REED 13822 OAKS AVENUE CHINO, CA 90710 USA		U.S. PAT. 5,150,991 5,645,379 AND PATS. PENDING	CE
MODEL NO.	<input type="text"/>		
SERIAL NO.	<input type="text"/>		
HP <input type="text"/>	VOLTAGE <input type="text"/>		
HZ <input type="text"/>	AMPS <input type="text"/>		
<small>13095D</small>			

7

(F)

WARNING
ALWAYS WEAR SAFETY GLASSES
WHEN OPERATING THIS MACHINE

8

(G)

**EXCESSIVE BOWL RPM MAY
CREATE PREMATURE PAD
WEAR AND EXCESSIVE DUST
COLLECTION (TO INCREASE
OUTPUT, FIRST INCREASE
CONVEYANCE AIR THEN BOWL
RPM).**

9

(H)



**SMALL AIR MOTOR (8AM)
DECAL ASSEMBLY**

**MACHINE OPERATOR MUST
SET OIL LUBRICATOR FLOW,
VALVES AND PAD ADJUSTING
STUDS, AT START UP AND AS
NEEDED DURING USE.**

10

J

ITEM NO.	REED'S PARTS NO.	DESCRIPTION	QTY
		1 2 3 4 5	
-1	10-05	Assembly, Small Air Motor Drive (8 Am) Unit Decal (See Group 10, Figure 01, 02, 03 and 04 for NHA)	Ref
2	10833	• Decal, REED Guncrete	2
3	10840	• Decal, WARNING , The Inside Hopper of this Machine has	1
4	10842	• Decal, CAUTION , Do Not Lift this Machine by Hopper Handle	2
5	10839	• Decal, WARNING , The Wear Pad Area of this Machine is	1
6	75005	• Decal, DANGER , Do not Put Your Hands	2
7	13095	• Nameplate, Guns Serial Number	1
-8	10838	• Decal, WARNING , Safety Glasses	1
9	13274	• Tag, Excessive Bowl RPM May Create Premature Pad Wear and	1
-10	13273	• Tag, Machine Operator Must Set Oil Lubricator Flow,	1
-11		• Ty-Rap	2

DASH (-) ITEM NOT ILLUSTRATED



MODEL LOVA PNEUMATIC SPRAYING MACHINE
ILLUSTRATED PARTS MANUAL

LOVA
PARTS
GROUP 10
FIGURE 06
PAGE 01

THIS PAGE INTENTIONALLY LEFT BLANK.

REVISION:

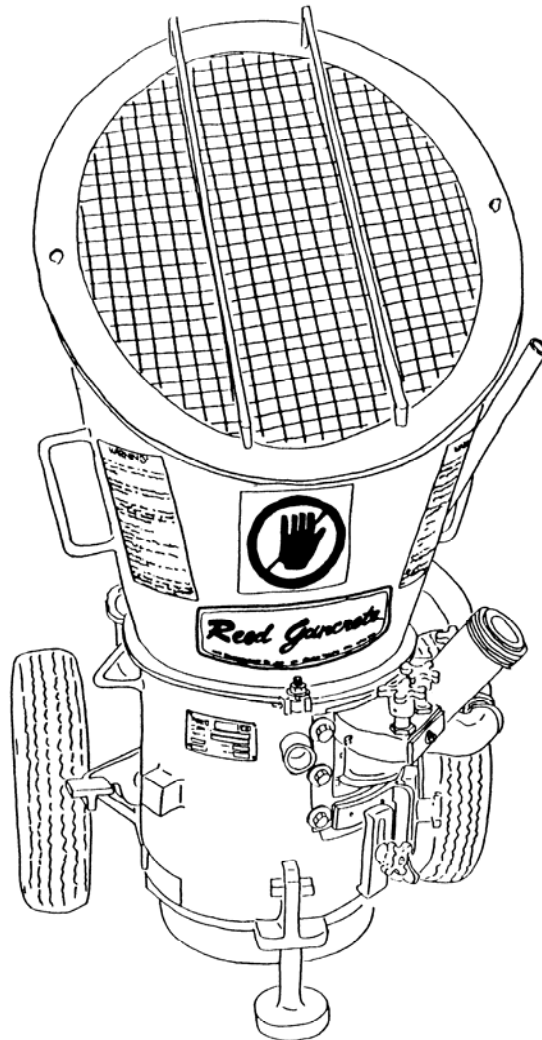

**SHOWN MODEL: LOVA™ SERIES 4
16 AM SHORT PREMIX HOPPER**

REED PNEUMATIC SPRAYING MACHINE MODEL LOVA™ SERIES 4 ILLUSTRATED PARTS MANUAL GROUP 20 LARGE AIR MOTOR DRIVE (16 AM) INSTALLATION CONTAINS THE FOLLOWING FIGURES:

FIGURE 00	TABLE OF CONTENTS
FIGURE 01	16 AM STANDARD HOPPER FINAL INSTALLATION
FIGURE 02	16 AM TALL PREMIX HOPPER FINAL INSTALLATION
FIGURE 03	16 AM SHORT PREMIX HOPPER FINAL INSTALLATION
FIGURE 04	16 AM REFRACTORY HOPPER FINAL INSTALLATION
FIGURE 05	LARGE AIR MOTOR DRIVE UNIT DECAL ASSEMBLY



LARGE AIR MOTOR DRIVE (16AM)
STANDARD HOPPER
FINAL INSTALLATION

LOVA
PARTS
GROUP 20
FIGURE 01
PAGE 01

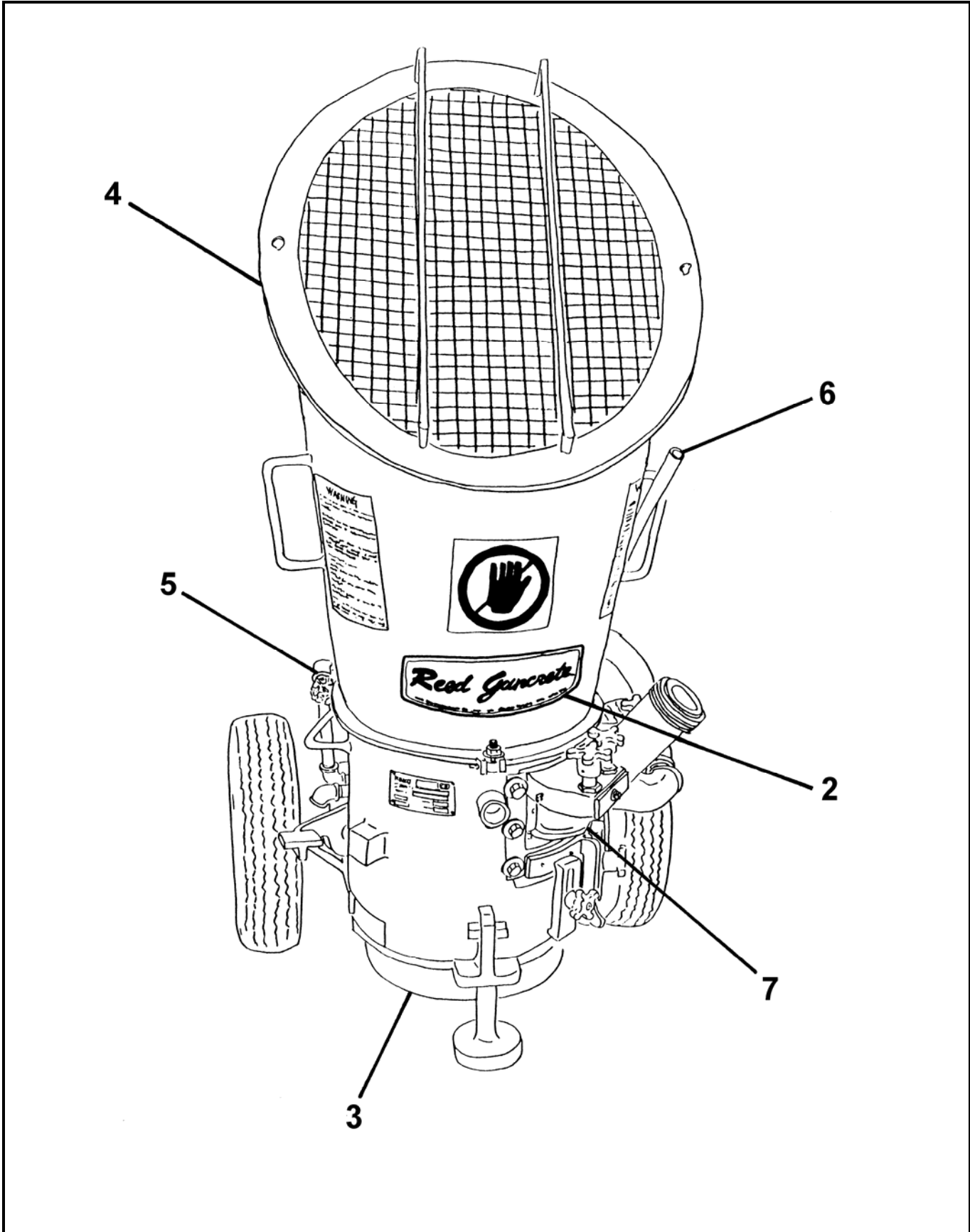

REVISION:



LARGE AIR MOTOR DRIVE (16AM)
STANDARD HOPPER
FINAL INSTALLATION

LOVA
PARTS
GROUP 20
FIGURE 01
PAGE 02

ITEM NO.	REED'S PARTS NO.	DESCRIPTION	QTY
		1 2 3 4 5	
-1	1200	Installation, Large Air Motor Drive (16 Am) Standard Hopper Final	Ref
2	20-05	• Assembly, Large Air Motor Drive (16 Am) Unit Decal (See Group 20, Figure 05 for DET)	1
3	30-01	• Installation, Base (See Group 30, Figure 01 for DET)	1
4	40-01	• Installation, Standard Hopper and Pad (See Group 40, Figure 01 for DET)	1
5	50-03	• Installation, 16 Am Air Inlet (See Group 50, Figure 03 for DET)	1
6	60-01	• Installation, Accessories (See Group 60, Figure 01 for DET)	1
7	70-01	• Installation, Optional (See Group 70, Figure 01 for DET)	1

DASH (-) ITEM NOT ILLUSTRATED

REVISION:



LARGE AIR MOTOR DRIVE (16AM)
TALL PREMIX HOPPER
FINAL INSTALLATION

LOVA
PARTS
GROUP 20
FIGURE 02
PAGE 01

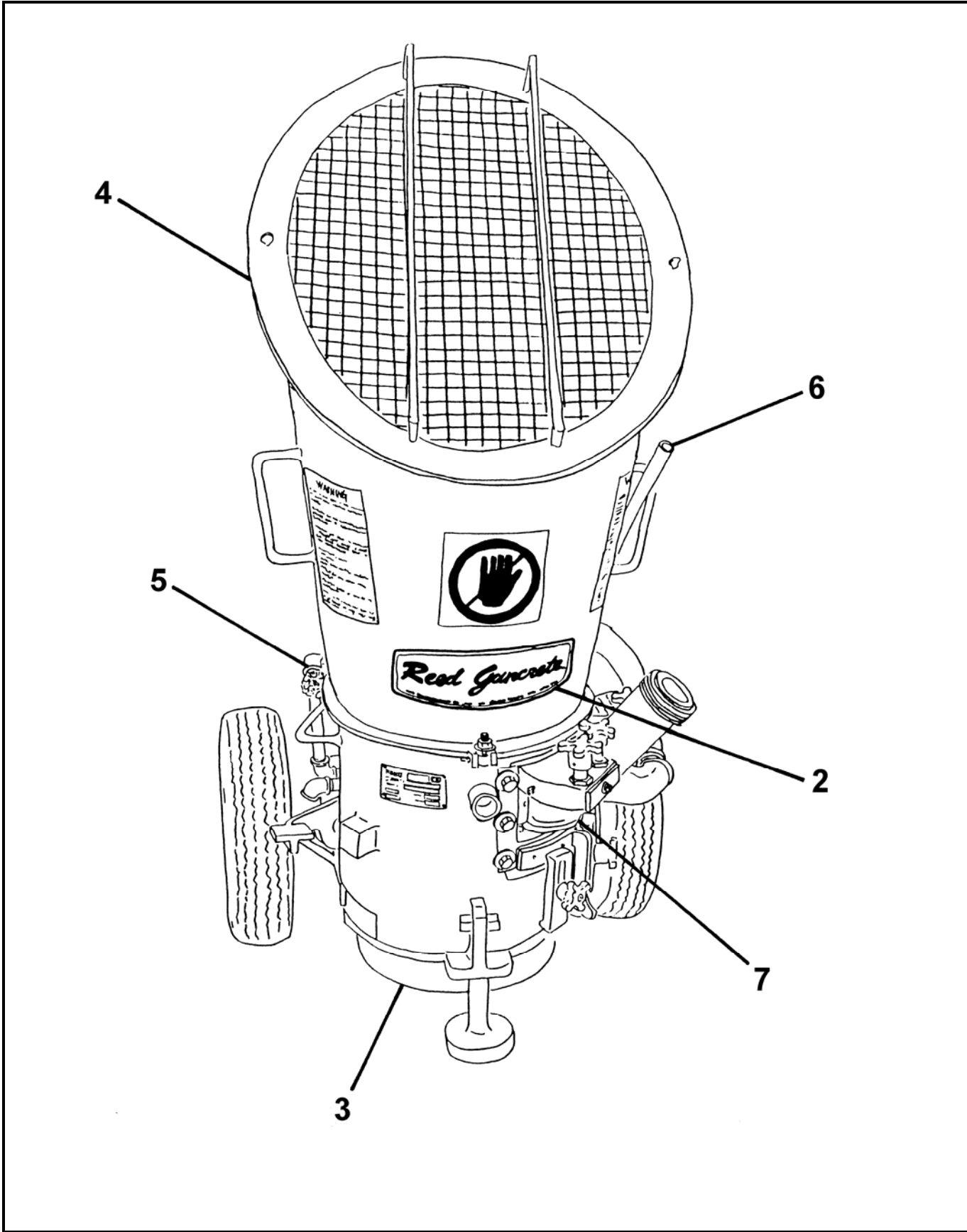

REVISION:



LARGE AIR MOTOR DRIVE (16AM)
TALL PREMIX HOPPER
FINAL INSTALLATION

LOVA
PARTS
GROUP 20
FIGURE 02
PAGE 02

ITEM NO.	REED'S PARTS NO.	DESCRIPTION	QTY
		1 2 3 4 5	
-1	1206	Installation, Large Air Motor Drive (16 Am) Tall Premix Hopper Final	Ref
2	20-05	• Assembly, Large Air Motor Drive (16 Am) Unit Decal (See Group 20, Figure 05 for DET)	1
3	30-01	• Installation, Base (See Group 30, Figure 01 for DET)	1
4	40-02	• Installation, Premix Hopper and Pad (See Group 40, Figure 02 for DET)	1
5	50-03	• Installation, 16 Am Air Inlet (See Group 50, Figure 03 for DET)	1
6	60-01	• Installation, Accessories (See Group 60, Figure 01 for DET)	1
7	70-01	• Installation, Optional (See Group 70, Figure 01 for DET)	1

DASH (-) ITEM NOT ILLUSTRATED

REVISION:



LARGE AIR MOTOR DRIVE (16AM)
SHORT PREMIX HOPPER
FINAL INSTALLATION

LOVA
PARTS
GROUP 20
FIGURE 03
PAGE 01

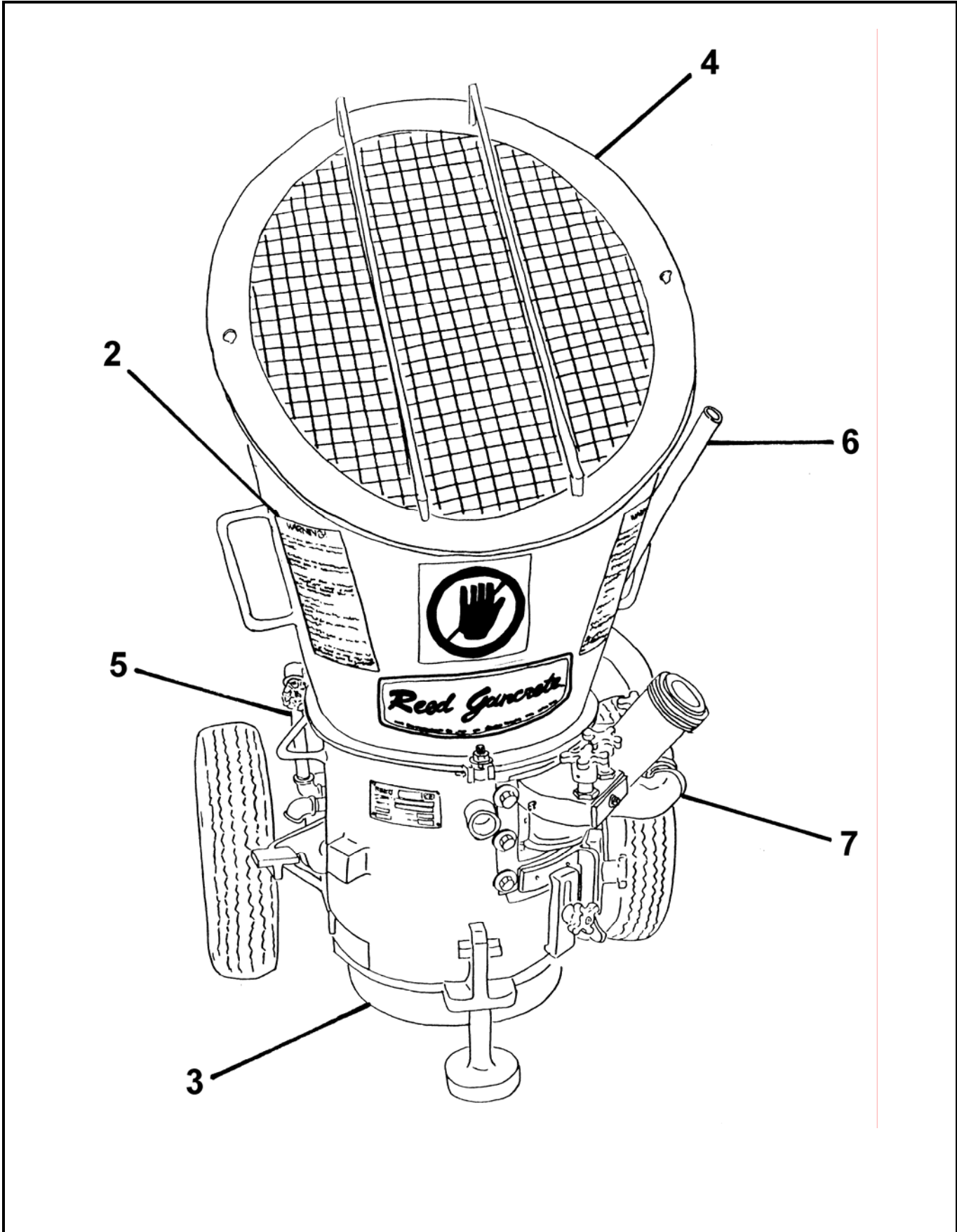

REVISION:



LARGE AIR MOTOR DRIVE (16AM)
SHORT PREMIX HOPPER
FINAL INSTALLATION

LOVA
PARTS
GROUP 20
FIGURE 03
PAGE 02

ITEM NO.	REED'S PARTS NO.	DESCRIPTION	QTY
		1 2 3 4 5	
-1	1212	Installation, Large Air Motor Drive (16 Am) Short Premix Hopper Final	Ref
2	20-05	• Assembly, Large Air Motor Drive (16 Am) Unit Decal (See Group 20, Figure 05 for DET)	1
3	30-01	• Installation, Base (See Group 30, Figure 01 for DET)	1
4	40-03	• Installation, Short Hopper and Pad (See Group 40, Figure 03 for DET)	1
5	50-03	• Installation, 16 Am Air Inlet (See Group 50, Figure 03 for DET)	1
6	60-01	• Installation, Accessories (See Group 60, Figure 01 for DET)	1
7	70-01	• Installation, Optional (See Group 70, Figure 01 for DET)	1

DASH (-) ITEM NOT ILLUSTRATED

REVISION:



LARGE AIR MOTOR DRIVE (16AM)
REFRACTORY HOPPER
FINAL INSTALLATION

LOVA
PARTS
GROUP 20
FIGURE 04
PAGE 01

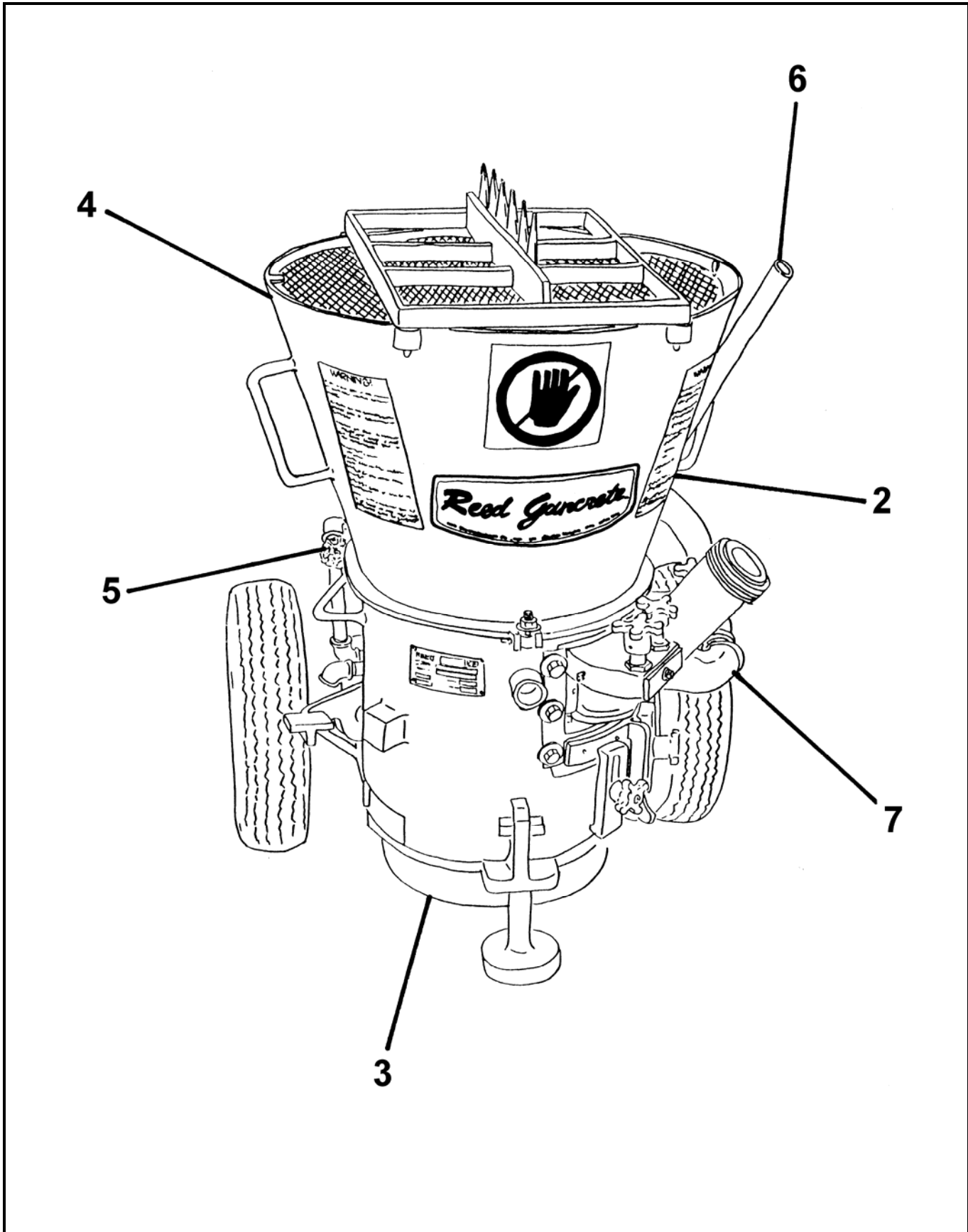

REVISION:



LARGE AIR MOTOR (16AM)
REFRACTORY HOPPER
FINAL INSTALLATION

LOVA
PARTS
GROUP 20
FIGURE 04
PAGE 02

ITEM NO.	REED'S PARTS NO.	DESCRIPTION	QTY
		1 2 3 4 5	
-1	1260	Installation, Large Air Motor Drive (16 Am) Refractory Hopper Final	Ref
2	20-05	• Assembly, Large Air Motor Drive (16 Am) Unit Decal (See Group 20, Figure 05 for DET)	1
3	30-01	• Installation, Base (See Group 30, Figure 01 for DET)	1
4	40-04	• Installation, Refractory Hopper and Pad (See Group 40, Figure 04 for DET)	1
5	50-04	• Installation, 16 Am Air Inlet for Refractory Hopper (See Group 50, Figure 04 for DET)	1
6	60-01	• Installation, Accessories (See Group 60, Figure 01 for DET)	1
7	70-01	• Installation, Optional (See Group 70, Figure 01 for DET)	1

DASH (-) ITEM NOT ILLUSTRATED

REVISION:



LARGE AIR MOTOR (16AM)
DECAL ASSEMBLY

LOVA
PARTS
GROUP 20
FIGURE 05
PAGE 01

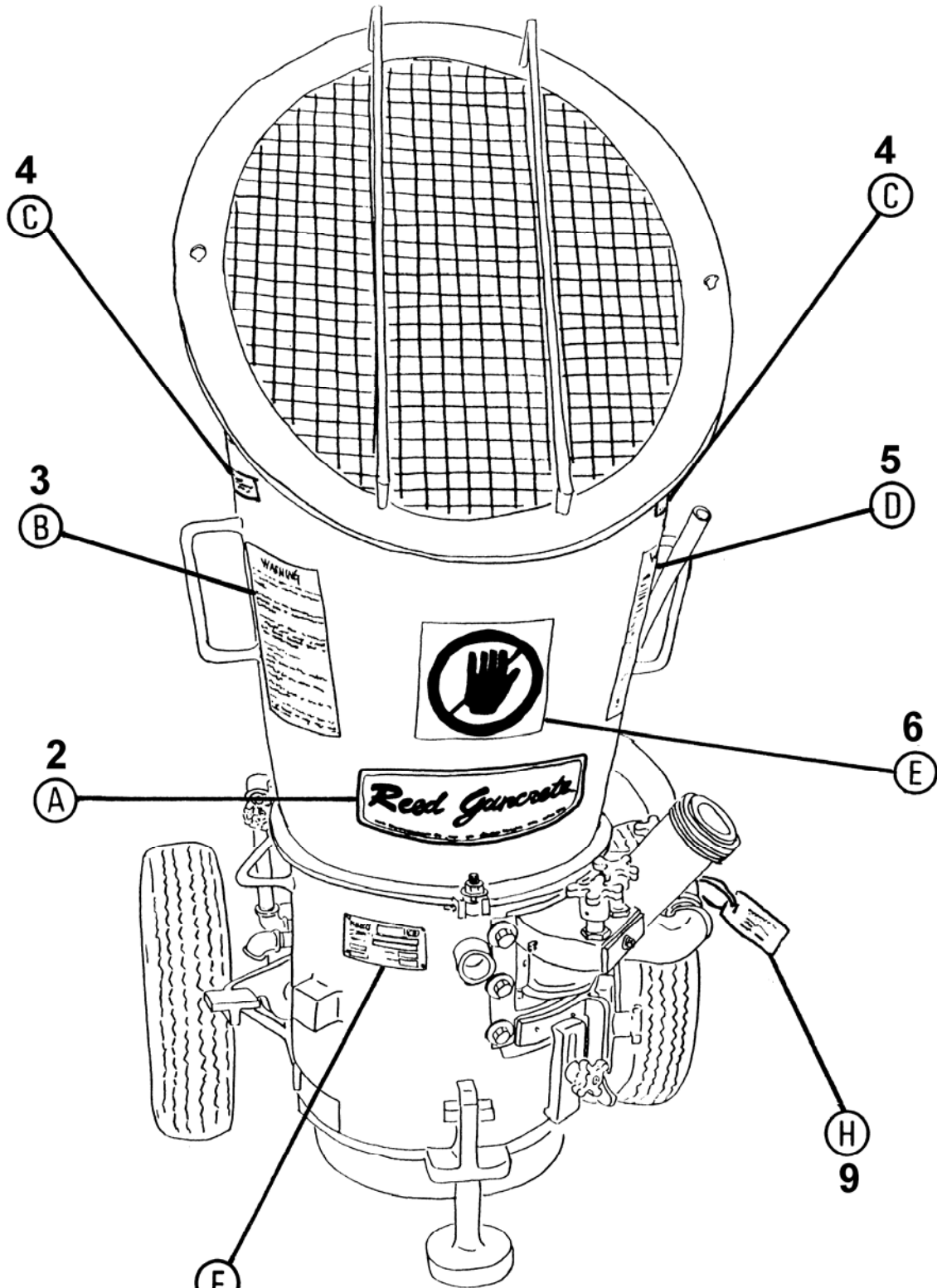

SHOWN MODEL: LOVA™ SERIES IV
8 AM STANDARD HOPPER

REVISION:



LARGE AIR MOTOR DRIVE (16AM)
DECAL ASSEMBLY

LOVA
PARTS
GROUP 20
FIGURE 05
PAGE 02

ITEM NO.	REED'S PARTS NO.	DESCRIPTION	QTY
		1 2 3 4 5	
-1	20-05	Assembly, Large Air Motor Drive (16 Am) Unit Decal (See Group 20, Figure 01, 02, 03 and 04 for NHA)	Ref
2	10833	• Decal, REED Guncrete	2
3	10840	• Decal, WARNING , The Inside Hopper of this Machine has	1
4	10842	• Decal, CAUTION , Do Not Lift this Machine by Hopper Handle	2
5	10839	• Decal, WARNING , The Wear Pad Area of this Machine is	1
6	75005	• Decal, DANGER , Do not Put Your Hands	2
7	13095	• Nameplate, Guns Serial Number	1
-8	10838	• Decal, WARNING , Safety Glasses	1
9	13274	• Tag, Excessive Bowl RPM May Create Premature Pad Wear and	1
-10	13273	• Tag, Machine Operator Must Set Oil Lubricator Flow,	1
-11		• Ty-Rap	2

DASH (-) ITEM NOT ILLUSTRATED



(A)

2



WARNING!

The inside of the hopper of this machine has moving parts which are extremely dangerous.

It is essential that strict safety procedures be followed before any work is done inside the hopper.

The screen on the hopper is bolted in a closed position to restrict access. If maintenance must be performed inside the hopper, proceed as follows:

- (1) Shut off power source.
air / electric
- (2) Disconnect air feed line or electrical cord.
- (3) Remove bolts securing the hopper screen.

Work inside the hopper may now be performed safely.

Upon completion of the work, replace the bolts and secure the hopper screen in a closed position. Reconnect air feed line or electrical cord and restore power.

(B)

3



LARGE AIR MOTOR (16AM)
DECAL ASSEMBLY

LOVA
PARTS
GROUP 20
FIGURE 05
PAGE 04

CAUTION DO NOT LIFT
THIS MACHINE BY HOPPER HANDLES.
USE SLINGS UNDER MACHINE.

4



WARNING!

The wear pad area of this machine is extremely dangerous when the wear pad and pad back-up assembly are removed.

It is essential that strict safety procedures be followed before performing any work in the wear pad area.

If maintenance must be performed in this area then proceed as follows:

- (1) Shut off power.
air / electric
- (2) Disconnect air feed line or electric cord.

5



Work in the wear pad area can now be performed safely.

Upon completion of this work, reconnect air feed line or electrical cord, and restore power.



LARGE AIR MOTOR (16AM)
DECAL ASSEMBLY

LOVA
PARTS
GROUP 20
FIGURE 05
PAGE 05



6

(E)

REED 13822 OAKS AVENUE CHINO, CA 90710 USA	U.S. PAT. 5,150,991 5,645,379 AND PATS. PENDING	CE
MODEL NO.	_____	
SERIAL NO.	_____	
HP _____	VOLTAGE _____	
HZ _____	AMPS _____	
<small>13095D</small>		

7

(F)

WARNING
ALWAYS WEAR SAFETY GLASSES
WHEN OPERATING THIS MACHINE

8

(G)

**EXCESSIVE BOWL RPM MAY
CREATE PREMATURE PAD
WEAR AND EXCESSIVE DUST
COLLECTION (TO INCREASE
OUTPUT, FIRST INCREASE
CONVEYANCE AIR THEN BOWL
RPM).**

9

(H)



**LARGE AIR MOTOR (16AM)
DECAL ASSEMBLY**

**LOVA
PARTS
GROUP 20
FIGURE 05
PAGE 06**

**MACHINE OPERATOR MUST
SET OIL LUBRICATOR FLOW,
VALVES AND PAD ADJUSTING
STUDS, AT START UP AND AS
NEEDED DURING USE.**

10



ITEM NO.	REED'S PARTS NO.	DESCRIPTION	QTY
		1 2 3 4 5	
-1	20-05	Assembly, Large Air Motor Drive (16 Am) Unit Decal (See Group 20, Figure 01, 02, 03 and 04 for NHA)	Ref
2	10833	• Decal, REED Gconcrete	2
3	10840	• Decal, WARNING , The Inside Hopper of this Machine has	1
4	10842	• Decal, CAUTION , Do Not Lift this Machine by Hopper Handle	2
5	10839	• Decal, WARNING , The Wear Pad Area of this Machine is	1
6	75005	• Decal, DANGER , Do not Put Your Hands	2
7	13095	• Nameplate, Guns Serial Number	1
-8	10838	• Decal, WARNING , Safety Glasses	1
9	13274	• Tag, Excessive Bowl RPM May Create Premature Pad Wear and	1
-10	13273	• Tag, Machine Operator Must Set Oil Lubricator Flow,	1
-11		• Ty-Rap	2

DASH (-) ITEM NOT ILLUSTRATED



MODEL LOVA PNEUMATIC SPRAYING MACHINE
ILLUSTRATED PARTS MANUAL

LOVA
PARTS
GROUP 20
FIGURE 06
PAGE 01

THIS PAGE INTENTIONALLY LEFT BLANK.

REVISION:

REED PNEUMATIC SPRAYING MACHINE MODEL LOVA™ SERIES 4 ILLUSTRATED PARTS MANUAL GROUP 30 BASE GEAR INSTALLATION CONTAINS THE FOLLOWING FIGURES:

- FIGURE 00** TABLE OF CONTENTS
- FIGURE 01** BASE GEAR INSTALLATION
- FIGURE 02** BASE GEAR ASSEMBLY
- FIGURE 03** DRIVE SPINDLE ASSEMBLY

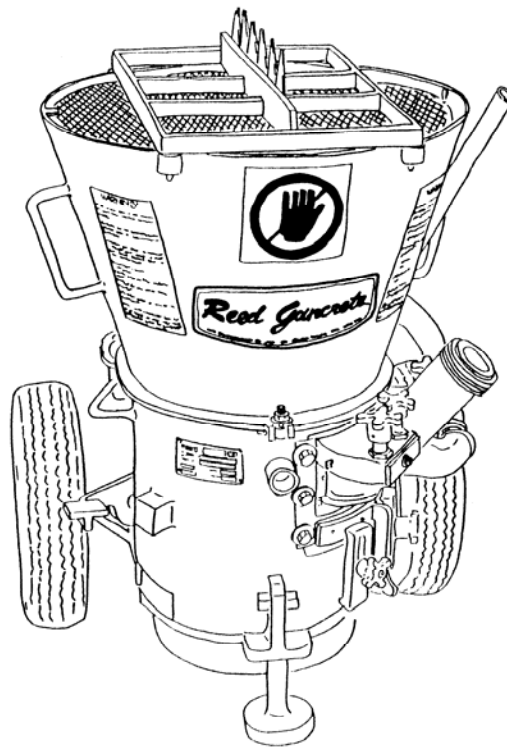

**SHOWN MODEL: LOVA™ SERIES IV
16 AM REFRACTORY HOPPER**



BASE GEAR INSTALLATION

LOVA
PARTS
GROUP 30
FIGURE 01
PAGE 01

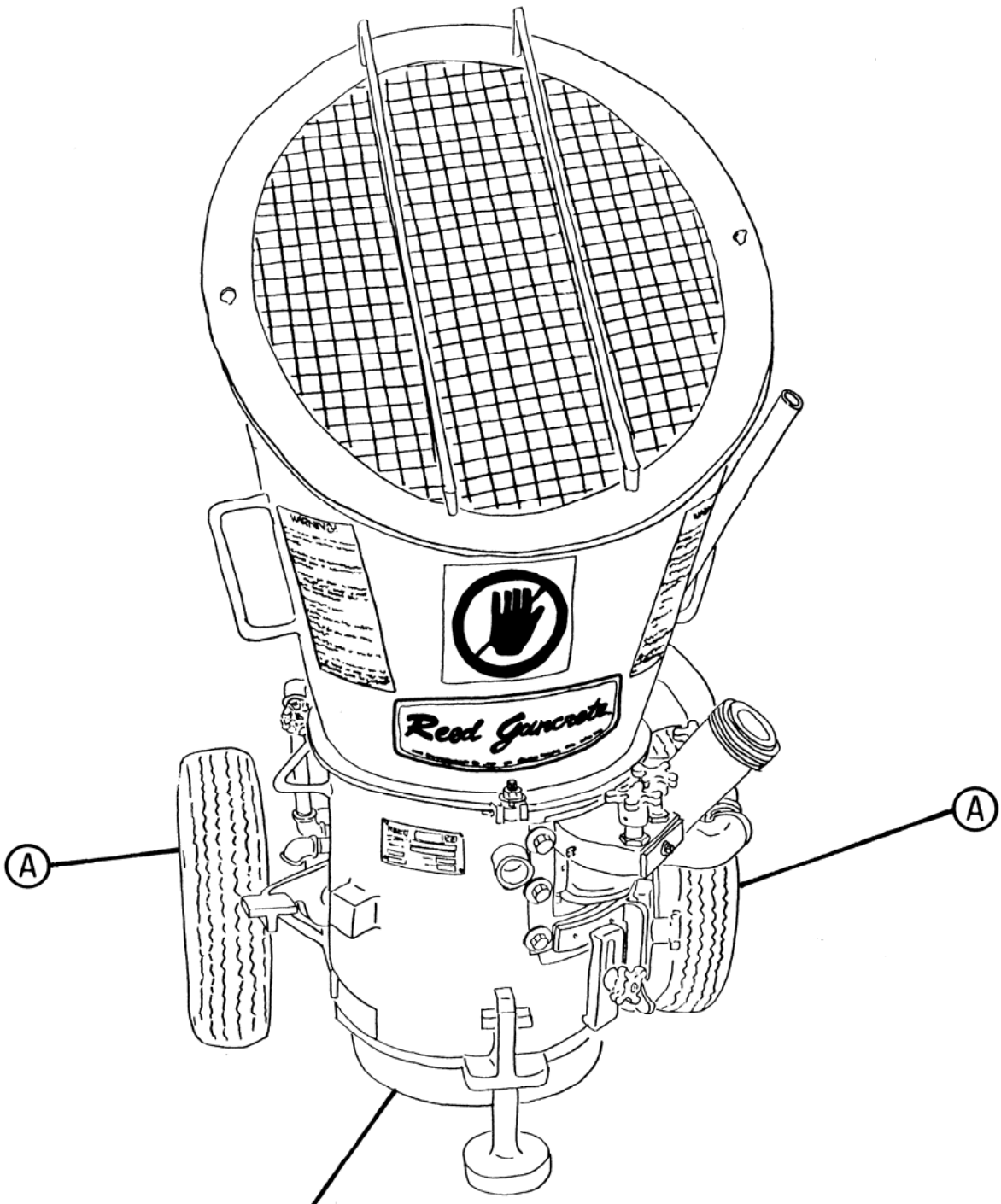

2 SHOWN MODEL: LOVA™ SERIES 4
8 AM SHORT PREMIX HOPPER

REVISION:

BASE GEAR INSTALLATION

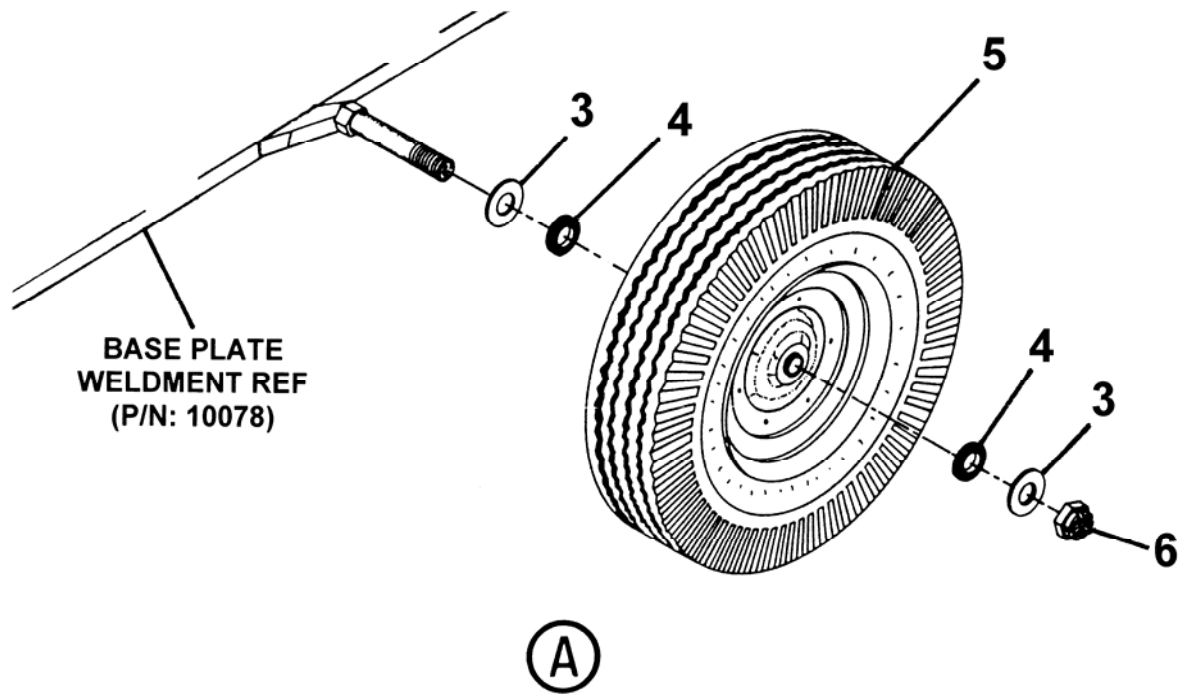

ITEM NO.	REED'S PARTS NO.	DESCRIPTION	QTY
-1	30-01	1 2 3 4 5 Installation, Base Gear (See Group 10, Figure 01, 02, 03, 04, Group 20, Figure 01, 02, 03, and 04 for NHA)	Ref
2	10049	• Assembly, Base Gear (See Group 30, Figure 02 for DET)	1
3		• Washer, Flat	8
4	10714	• Washer, Felt	8
5	10713	• Assembly, Wheel and Tire	2
-5A	13321	• • Beating, Wheel	1
6	10738	• Nut, Flex Lock	4

DASH (-) ITEM NOT ILLUSTRATED



BASE GEAR ASSEMBLY

LOVA
PARTS
GROUP 30
FIGURE 02
PAGE 01

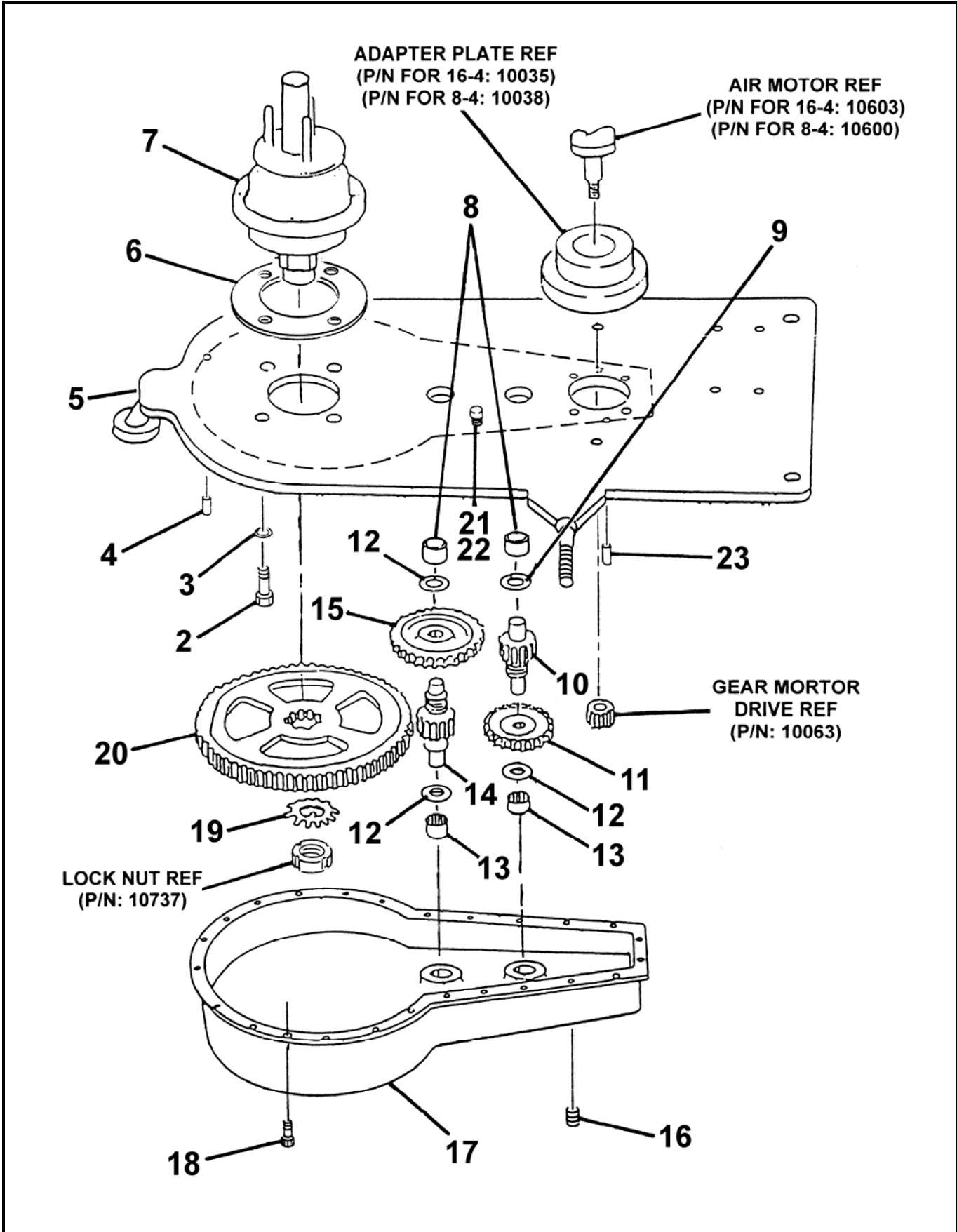

REVISION:



BASE GEAR ASSEMBLY

LOVA
PARTS
GROUP 30
FIGURE 02
PAGE 02

ITEM NO.	REED'S PARTS NO.	DESCRIPTION	QTY
		1 2 3 4 5	
-1	10049	Assembly, Base Gear (See Group 30, Figure 01 for NHA)	Ref
2	80153	• Screw, Hex Cap	4
3	80074	• Washer, Lock	4
4	80361	• Pin, Dowel 2	2
5	10078	• Weldment, Base Plate	1
6	10705	• Gasket, Drive Spindle	1
7	10089	• Assembly, Drive Spindle (See Group 30, Figure 03 for DET)	1
8	10716	• Bearing, Pinion	2
9	10718	• Washer, Thrust	1
10	10720	• Shaft, Pinion Gear	1
11	10721	• Gear	1
12	10717	• Washer, Thrust	3
13	10723	• Bearing, Pinion	2
14	10724	• Shaft, Pinion Gear	1
15	10722	• Gear	1
16	74943	• Plug, Drain	1
17	10725	• Housing, Gear pan	1
18	80253	• Screw, Socket Head	18
19	10736	• Washer, Lock	1
20	10715	• Gear, Bull	1
21	10706	• Cap, Oil Filler and Breather	1
22	10707	• Pipe, Oil Filler and Breather	1

DASH (-) ITEM NOT ILLUSTRATED

REVISION:



DRIVE SPINDLE ASSEMBLY

LOVA
PARTS
GROUP 30
FIGURE 03
PAGE 01

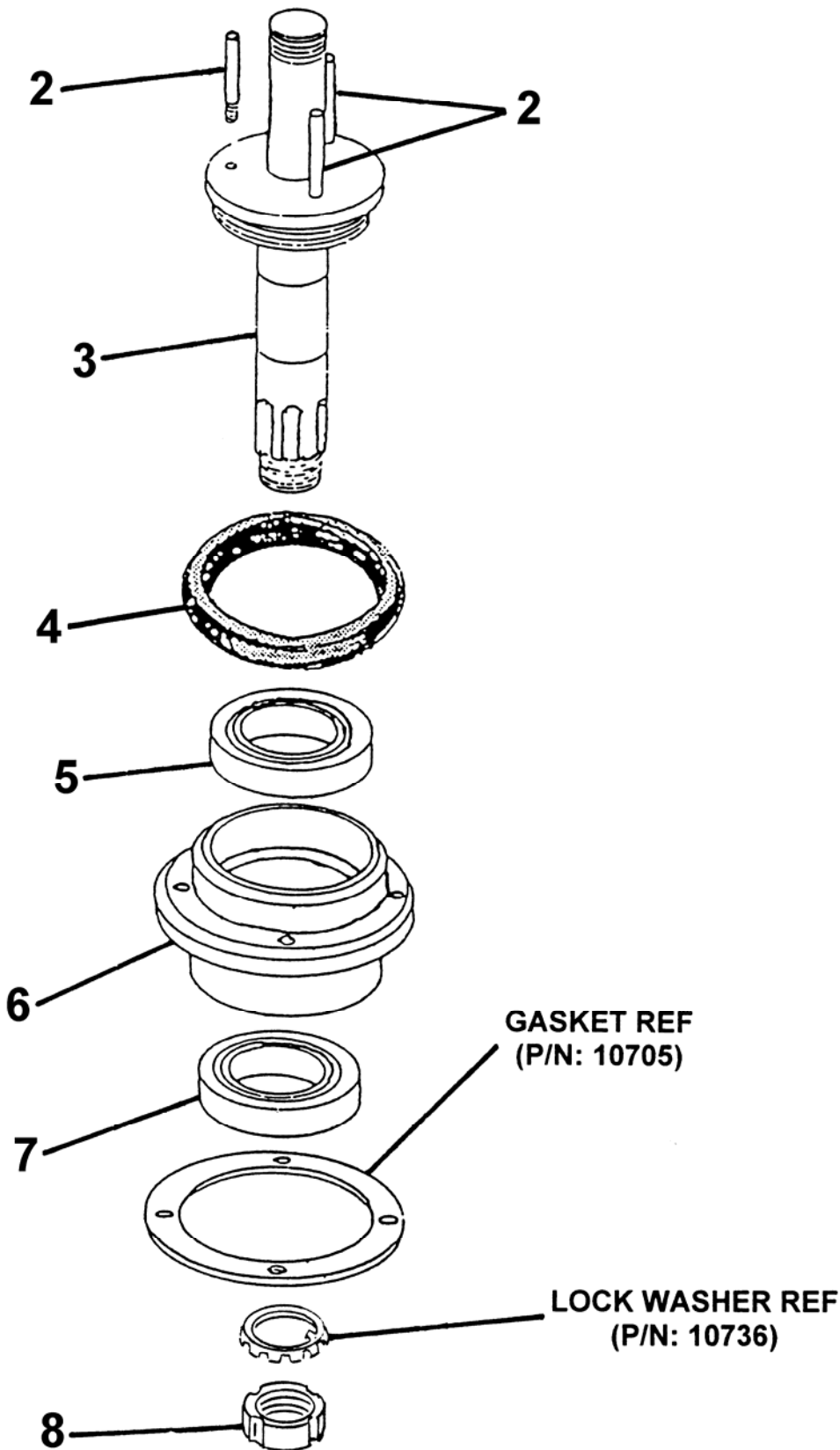

REVISION:



DRIVE SPINDLE ASSEMBLY

LOVA
PARTS
GROUP 30
FIGURE 03
PAGE 02

ITEM NO.	REED'S PARTS NO.	DESCRIPTION	QTY
		1 2 3 4 5	
-1	10089	Assembly, Drive Spindle (See Group 30, Figure 02 for NHA)	Ref
2	10728	• Stud, Spindle	3
3	10729	• Hub, Splined Spindle	1
4	10701	• Seal, Spindle	1
5	10702	• Bearing, Upper Spindle	1
6	10703	• Housing, Grey Iron	1
7	10704	• Bearing, Lower Spindle	1
8	10737	• Nut, Lock	1

DASH (-) ITEM NOT ILLUSTRATED

REVISION:



MODEL LOVA PNEUMATIC SPRAYING MACHINE
ILLUSTRATED PARTS MANUAL

LOVA
PARTS
GROUP 30
FIGURE 04
PAGE 01

THIS PAGE INTENTIONALLY LEFT BLANK.

REVISION:

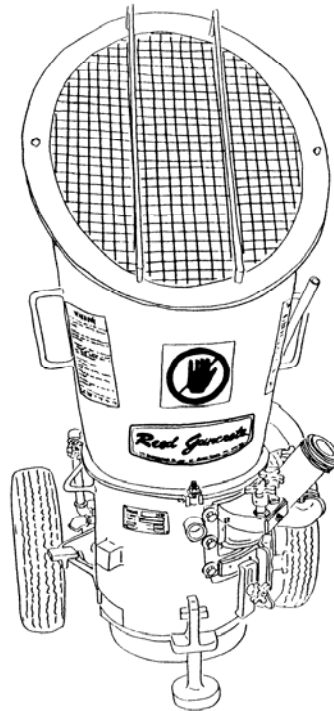

**SHOWN MODEL: LOVA™ SERIES 4
8 AM TALL PREMIX HOPPER**

REED PNEUMATIC SPRAYING MACHINE MODEL LOVA™ SERIES 4 ILLUSTRATED PARTS MANUAL GROUP 40 HOPPER AND PAD INSTALLATION CONTAINS THE FOLLOWING FIGURES:

- | | |
|------------------|--|
| FIGURE 00 | TABLE OF CONTENTS |
| FIGURE 01 | STANDARD HOPPER AND PAD INSTALLATION |
| FIGURE 02 | TALL PREMIX HOPPER AND PAD INSTALLATION |
| FIGURE 03 | SHORT PREMIX HOPPER AND PAD INSTALLATION |
| FIGURE 04 | REFRACTORY HOPPER AND PAD INSTALLATION |
| FIGURE 05 | FEED WHEEL PAD HOUSING INSTALLATION |
| FIGURE 06 | PAD HOUSING ASSEMBLY |
| FIGURE 07 | KNOB GUIDE ASSEMBLY |
| FIGURE 08 | PAD ADJUSTING STUD ASSEMBLY |
| FIGURE 09 | 12 POCKET WITH DIVIDER FEED WHEEL
AND PAD BACKUP INSTALLATION |
| FIGURE 10 | 2 INCH SOLID LARGE AGGREGATE PAD BACKUP ASSEMBLY |



STANDARD HOPPER AND PAD INSTALLATION

LOVA
PARTS
GROUP 40
FIGURE 01
PAGE 01

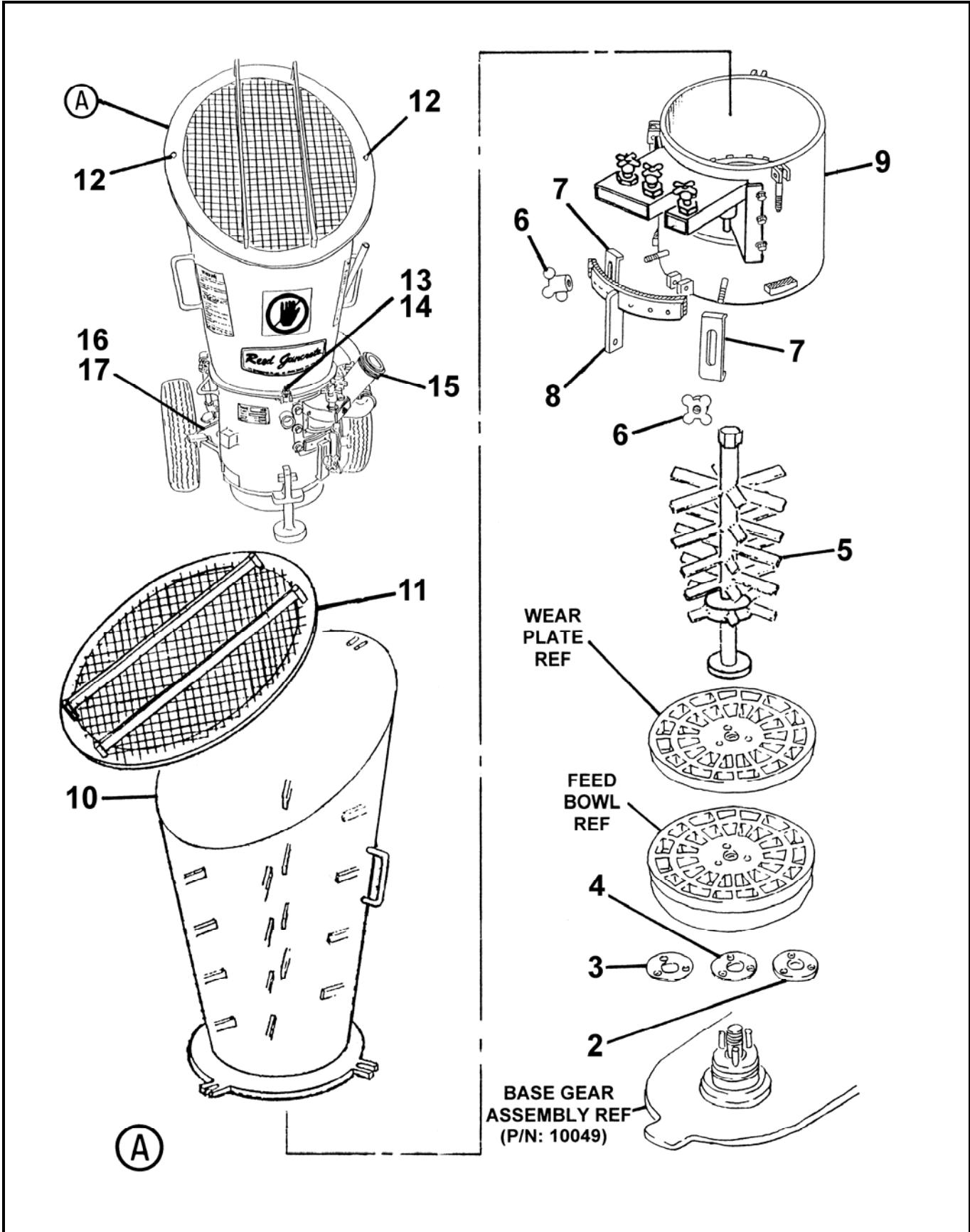

REVISION:



STANDARD HOPPER
AND PAD INSTALLATION

LOVA
PARTS
GROUP 40
FIGURE 01
PAGE 02

ITEM NO.	REED'S PARTS NO.	DESCRIPTION	QTY
		1 2 3 4 5	
-1	40-01	Assembly, Standard Hopper and Pad (See Group 10, Figure 01 and Group 20, Figure 01 for NHA)	Ref
2	10826	• Plate, Thick Riser	A/R
3	10827	• Plate, Thin Riser	A/R
4	10825	• Plate, Medium Riser	A/R
5	10812	• Weldment, 30 Blade Agitator	1
6	20075	• Knob, Pad Clamp	2
7	20072	• Clamp, Block Pad	2
8	10039	• Weldment, Pad Clamp	1
9	10071	• Installation, Pad Housing (See Group 40, Figure 05 for DET)	1
10	10902	• Weldment, Standard Mixer Hopper	2
11	10906	• Weldment, 8 AM 1" Mesh Screen	1
	10905	• Weldment, 16 AM 1" Mesh Screen	1
12		• Screw, Thumb	2
13		• Bolt, Hex	3
14		• Washer, Flat	3
15	40-09	• Installation, 12 Pocket with Divider Feed Wheel and Pad Backup (See Group 40, Figure 09 for DET)	1
16	10731	• Weldment, Kicker Bar and Foot Pedal	1
17	10735	• Bolt, Shoulder	1

DASH (-) ITEM NOT ILLUSTRATED

REVISION:



TALL PREMIX HOPPER
AND PAD INSTALLATION

LOVA
PARTS
GROUP 40
FIGURE 02
PAGE 01

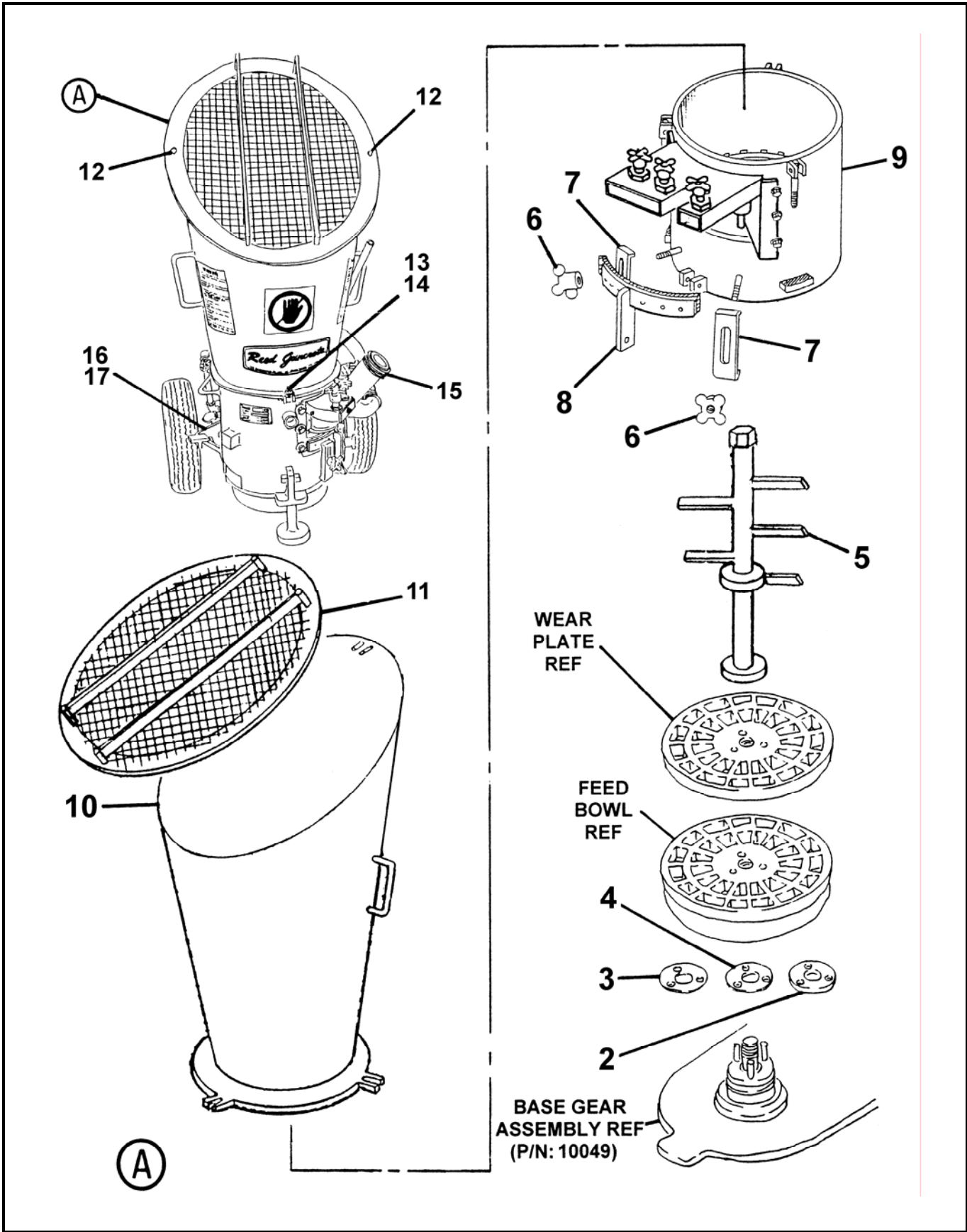

REVISION:



TALL PREMIX HOPPER
FINAL INSTALLATION

LOVA
PARTS
GROUP 40
FIGURE 02
PAGE 02

ITEM NO.	REED'S PARTS NO.	DESCRIPTION					QTY
		1	2	3	4	5	
-1	40-02	Assembly, Tall Premix Hopper and Pad (See Group 10, Figure 02 and Group 20, Figure 02 for NHA)					Ref
2	10826	• Plate, Thick Riser					A/R
3	10827	• Plate, Thin Riser					A/R
4	10825	• Plate, Medium Riser					A/R
5	10810	• Weldment, 2 Blade Agitator					1
6	20075	• Knob, Pad Clamp					2
7	20072	• Clamp, Block Pad					2
8	10039	• Weldment, Pad Clamp					1
9	10071	• Installation, Pad Housing (See Group 40, Figure 05 for DET)					1
10	10901	• Weldment, Tall Premix Hopper					2
11	10906	• Weldment, 8 AM 1" Mesh Screen					1
	10905	• Weldment, 16 AM 1" Mesh Screen					1
12		• Screw, Thumb					2
13		• Bolt, Hex					3
14		• Washer, Flat					3
15	40-09	• Installation, 12 Pocket with Divider Feed Wheel and Pad Backup (See Group 40, Figure 09 for DET)					1
16	10731	• Weldment, Kicker Bar and Foot Pedal					1
17	10735	• Bolt, Shoulder					1

DASH (-) ITEM NOT ILLUSTRATED

REVISION:



SHORT PREMIX HOPPER
AND PAD INSTALLATION

LOVA
PARTS
GROUP 40
FIGURE 03
PAGE 02

ITEM NO.	REED'S PARTS NO.	DESCRIPTION	QTY
		1 2 3 4 5	
-1	40-03	Assembly, Short Premix Hopper and Pad (See Group 10, Figure 03 and Group 20, Figure 03 for NHA)	Ref
2	10826	• Plate, Thick Riser	A/R
3	10827	• Plate, Thin Riser	A/R
4	10825	• Plate, Medium Riser	A/R
5	10810	• Weldment, 2 Blade Agitator	1
6	20075	• Knob, Pad Clamp	2
7	20072	• Clamp, Block Pad	2
8	10039	• Weldment, Pad Clamp	1
9	10071	• Installation, Pad Housing (See Group 40, Figure 05 for DET)	1
10	10900	• Weldment, Short Premix Hopper	2
11	10906	• Weldment, 8 AM 1" Mesh Screen	1
	10905	• Weldment, 16 AM 1" Mesh Screen	1
12		• Screw, Thumb	2
13		• Bolt, Hex	3
14		• Washer, Flat	3
15	40-09	• Installation, 12 Pocket with Divider Feed Wheel and Pad Backup (See Group 40, Figure 09 for DET)	1
16	10731	• Weldment, Kicker Bar and Foot Pedal	1
17	10735	• Bolt, Shoulder	1

DASH (-) ITEM NOT ILLUSTRATED

REVISION:



REFRACTORY HOPPER
AND PAD INSTALLATION

LOVA
PARTS
GROUP 40
FIGURE 04
PAGE 02

ITEM NO.	REED'S PARTS NO.	DESCRIPTION	QTY
		1 2 3 4 5	
-1	40-04	Assembly, Refractory Hopper and Pad (See Group 10, Figure 01 for NHA)	Ref
2	10826	• Plate, Thick Riser	A/R
3	10827	• Plate, Thin Riser	A/R
4	10825	• Plate, Medium Riser	A/R
5	10810	• Weldment, 2 Blade Agitator	1
6	20075	• Knob, Pad Clamp	2
7	20072	• Clamp, Block Pad	2
8	10039	• Weldment, Pad Clamp	1
9	10071	• Installation, Pad Housing (See Group 40, Figure 05 for DET)	1
10	10903	• Weldment, Refractory Hopper	2
11	10907	• Weldment, 3/4" Mesh Screen	1
12	10939	• Weldment, Bag Breaker	2
13		• Bolt, Hex	3
14		• Washer, Flat	3
15	40-09	• Installation, 12 Pocket with Divider Feed Wheel and Pad Backup (See Group 40, Figure 09 for DET)	1
16	10731	• Weldment, Kicker Bar and Foot Pedal	1
17	10735	• Bolt, Shoulder	1
18		• Screw, Thumb	1

DASH (-) ITEM NOT ILLUSTRATED

REVISION:

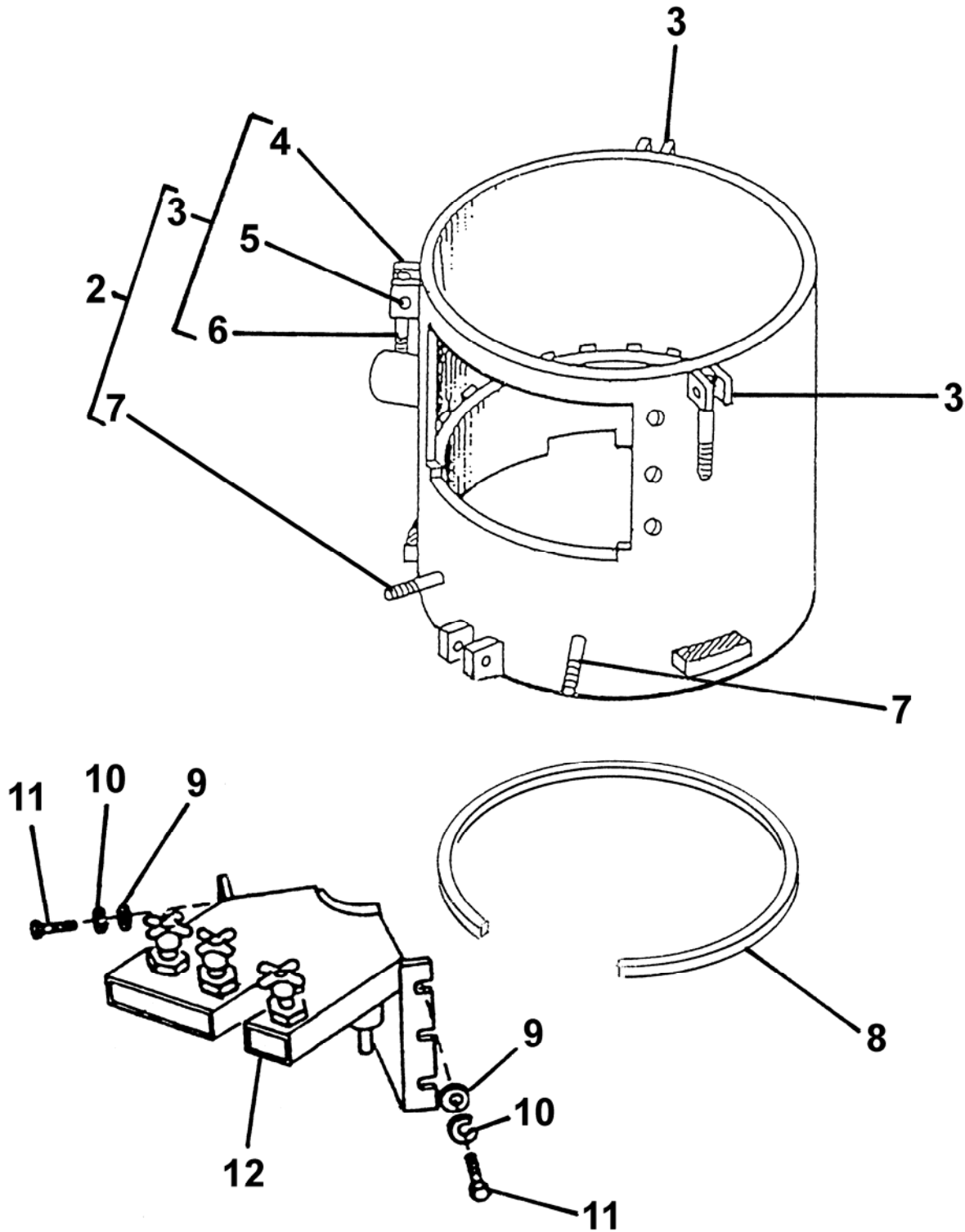



**FEED WHEEL
PAD HOUSING INSTALLATION**

**LOVA
PARTS
GROUP 40
FIGURE 05
PAGE 02**

ITEM NO.	REED'S PARTS NO.	DESCRIPTION	QTY
		1 2 3 4 5	
-1	10071	Installation, Feed Wheel Pad Housing (See Group 40, Figure 01, 02, 03 and 04 for NHA)	Ref
2	10020	• Assembly, Feed Wheel Housing	1
3	20066	•• Assembly, Swing Bolt	3
4	10927	••• Bracket, Swing Bolt	1
5	80297	••• Pin, Spring	1
6	20154	••• Bolt, Swing	1
7	10928	•• Stud, Clamp	2
8	10005	• Seal, Felt	1
9	80074	• Washer, Flat	6
10	80044	• Washer, SPL Lock	6
11	80151	• Bolt, Hex	6
12	10040	• Assembly, Pad Housing (See Group 40, Figure 06 for DET)	1

DASH (-) ITEM NOT ILLUSTRATED

REVISION:

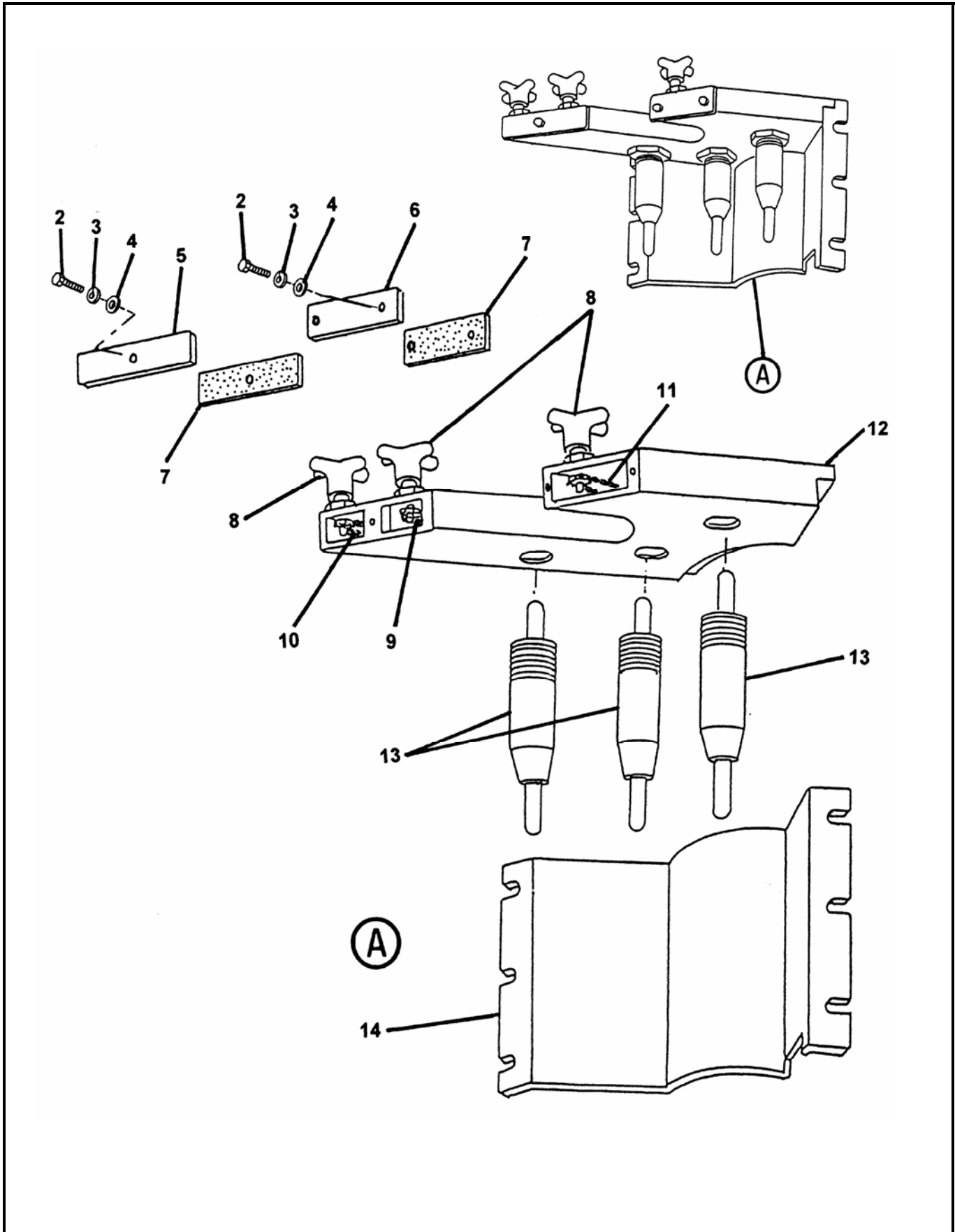



PAD HOUSING ASSEMBLY

LOVA
PARTS
GROUP 40
FIGURE 06
PAGE 02

ITEM NO.	REED'S PARTS NO.	DESCRIPTION	QTY
		1 2 3 4 5	
-1	10040	Assembly, Pad Housing (See Group 40, Figure 05 for NHA)	Ref
2	80091	• Screw, Hex Cap	3
3		• Washer, SPL Lock	3
4		• Washer, Flat	3
5	10074	• Weldment, Pad Housing Chain Cover	1
6	10096	• Weldment, Pad Housing Chain Cover	1
7	20182	• Gasket, Pad Housing	A/R
8	20187	• Assembly, Knob Guide (See Group 40, Figure 07 for DET)	3
9	10094	• Chain, Pad Adjusting Long	1
10	10093	• Chain, Pad Adjusting Medium	1
11	10092	• Chain, Pad Adjusting Short	1
12	10076	• Top, Pad Housing	1
13	10047	• Assembly, Pad Adjusting Stud (See Group 40, Figure 08 for DET)	3
14	10077	• Side, Pad Housing	1

DASH (-) ITEM NOT ILLUSTRATED

REVISION:

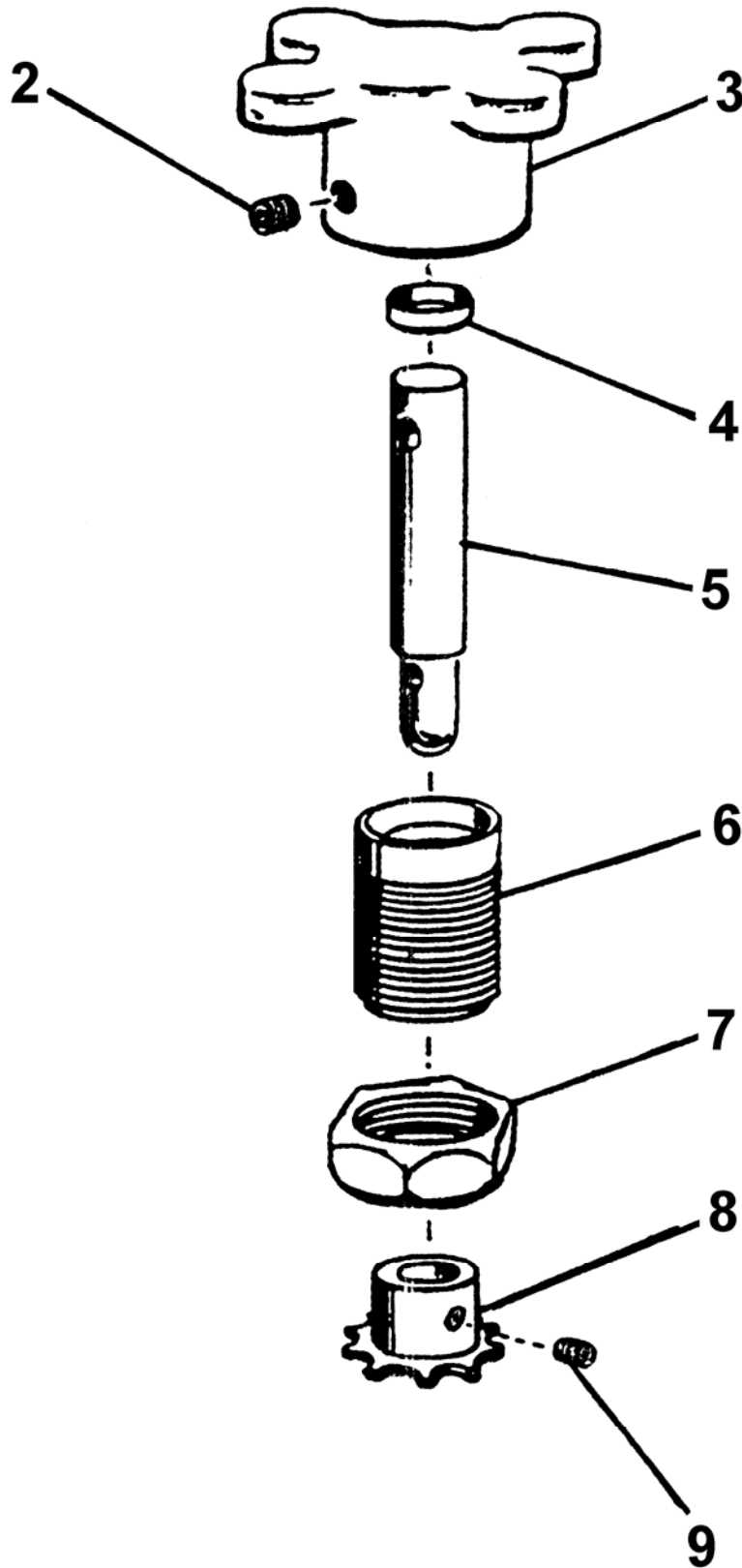



KNOB GUIDE ASSEMBLY

LOVA
PARTS
GROUP 40
FIGURE 07
PAGE 02

ITEM NO.	REED'S PARTS NO.	DESCRIPTION	QTY
		1 2 3 4 5	
-1	20187	Assembly, Knob Guide (See Group 40, Figure 06 for NHA)	Ref
2	80370	• Screw, Socket Set	1
3	20003	• Knob, Pad Adjusting	1
4	20002	• Seal, Pad Adjusting Stud	1
5	20021	• Stud, Pad Adjusting Knob	1
6	20020	• Guide, Pad Adjusting Knob	1
7	20005	• Nut, Pad Adjusting Jam	1
8	20004	• Sprocket, Pad Adjusting Chain	1
9	80369	• • Screw, Socket Set	1

DASH (-) ITEM NOT ILLUSTRATED

REVISION:



PAD ADJUSTING STUD ASSEMBLY

LOVA
PARTS
GROUP 40
FIGURE 08
PAGE 01

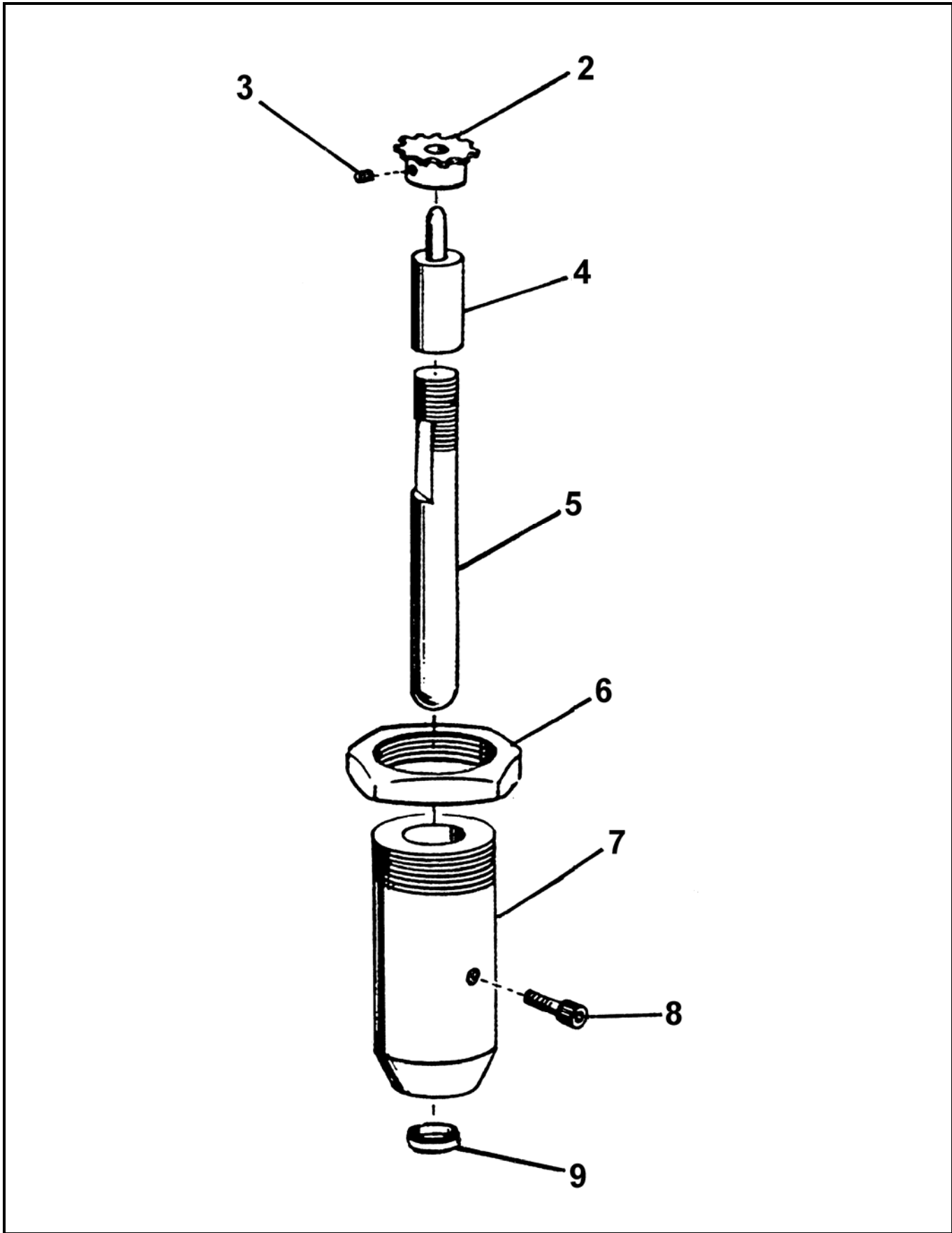

REVISION:



PAD ADJUSTING STUD ASSEMBLY

LOVA
PARTS
GROUP 40
FIGURE 08
PAGE 02

ITEM NO.	REED'S PARTS NO.	DESCRIPTION	QTY
		1 2 3 4 5	
-1	10047	Assembly, Pad Adjusting Stud (See Group 40, Figure 06 for NHA)	Ref
2	20004	• Sprocket, Pad Adjusting Chain with Set Screw	1
3	80369	• • Screw, Socket Set	1
4	20018	• Stud, Pad Adjusting Pusher	1
5	10018	• Stud, Pad Adjusting	1
6	20001	• Nut, Pad Adjusting Jam	1
7	20017	• guide, Pad Adjusting Stud	1
8	80252	• Screw, Socket Head Cap	1
9	20002	• Seal, Pad Adjusting Stud	1

DASH (-) ITEM NOT ILLUSTRATED

REVISION:

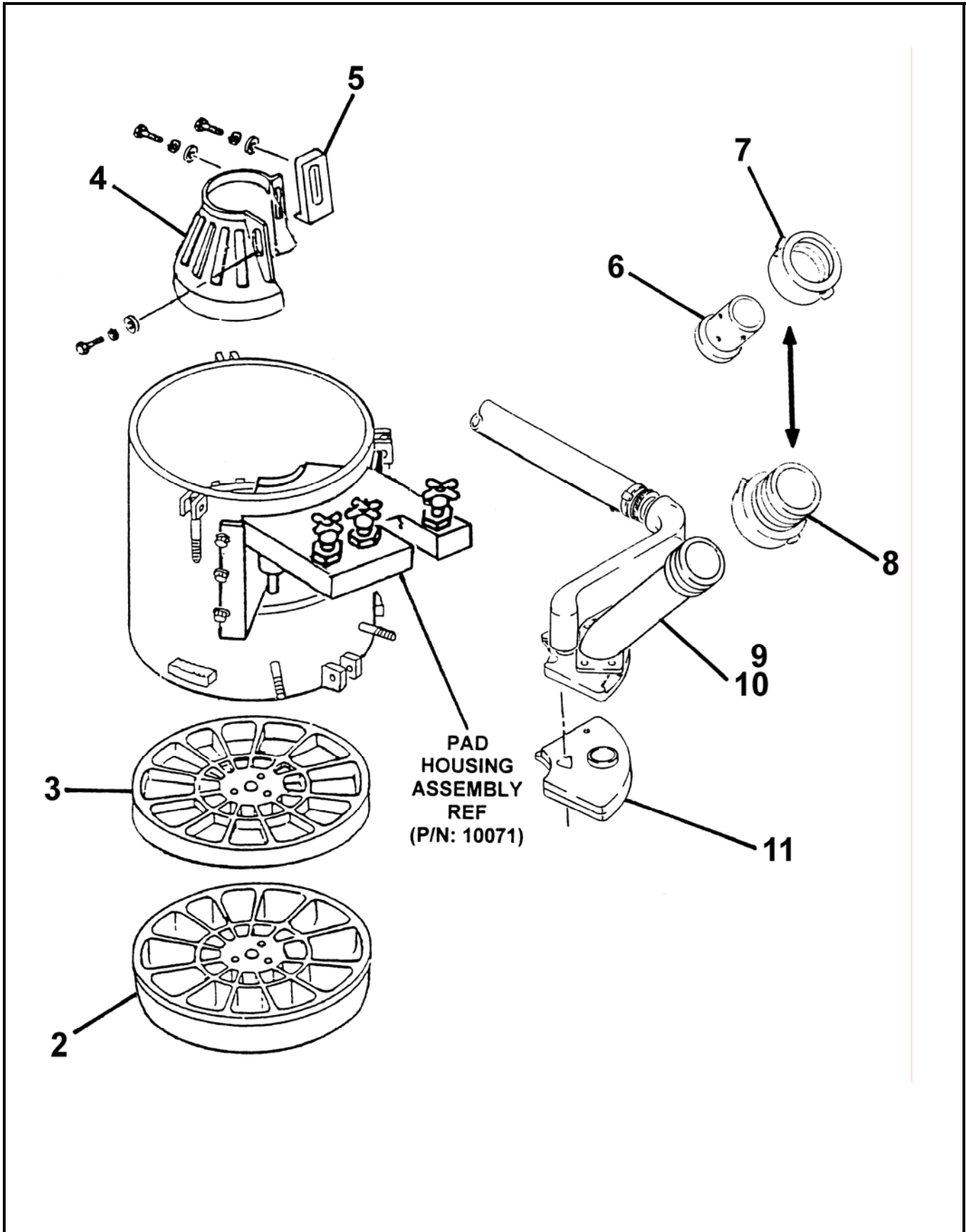



12 POCKET WITH DIVIDER FEED WHEEL
AND PAD BACKUP INSTALLATION

LOVA
PARTS
GROUP 40
FIGURE 09
PAGE 02

ITEM NO.	REED'S PARTS NO.	DESCRIPTION	QTY
		1 2 3 4 5	
-1	40-09	Installation, 12 Pocket with Divider Feed Wheel and Pad Backup (See Group 40, Figure 01, 02, 03 and 04 for NHA)	Ref
2	10797	• Feed Bowl, 12 Pocket with Divider	1
3	10796	• Plate, 12 Pocket with Divider	1
4	10922	• Cone, Rock	1
5	10014	• Shear, Narrow Rock	1
6	11021	• End, Coarse 2 Inch Female Hose (Optional Item)	1
7	11033	• Nut, Coarse 2 Inch Coupling (Optional Item)	1
8	12087	• Adapter, 2 Inch to 2-1/2 Inch Goose Neck (Optional Item)	1
9	10665	• Assembly, 2 Inch Solid Large Aggregate Pad Backup (Optional Item) (See Group 40, Figure 14 for DET)	1
10	10666	• Assembly, 2 Inch Liner Type Large Aggregate Pad Backup (Optional Item) (See Group 70, Figure 01 for DET)	1
11	10336	• Wearpad, Rubber	1

DASH (-) ITEM NOT ILLUSTRATED

REVISION:



2 INCH SOLID LARGE AGGREGATE
PAD BACKUP ASSEMBLY

LOVA
PARTS
GROUP 40
FIGURE 10
PAGE 01

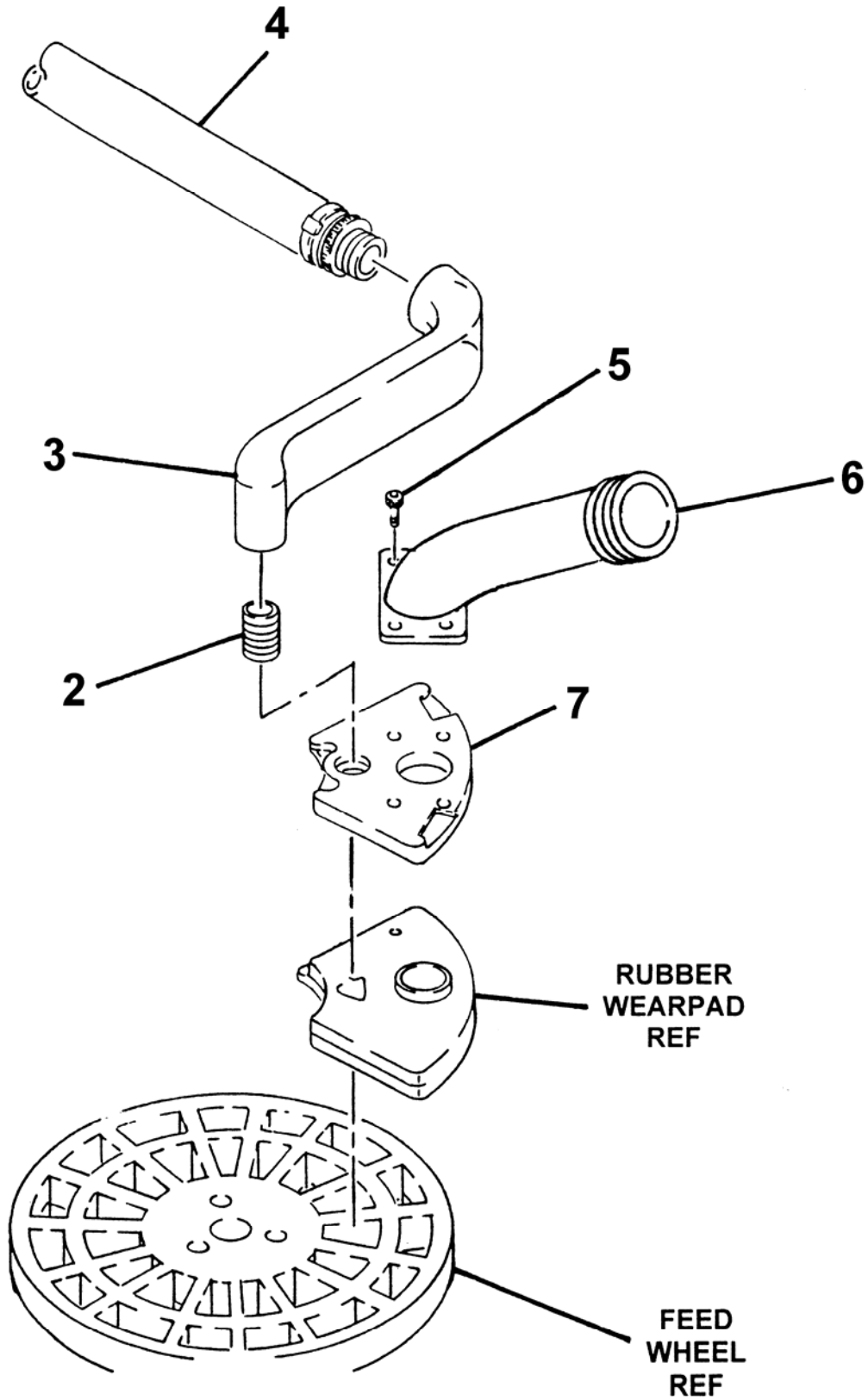

REVISION:



2 INCH SOLID LARGE AGGREGATE
PAD BACKUPASSEMBLY

LOVA
PARTS
GROUP 40
FIGURE 10
PAGE 02

ITEM NO.	REED'S PARTS NO.	DESCRIPTION	QTY
		1 2 3 4 5	
-1	10665	Assembly, 2 Inch Solid Large Aggregate Pad Backup (See Group 40, Figure 09and Group 70, Figure 03, 05 and 06 and for NHA)	Ref
2	10232	• Nipple	1
3	10219	• Inlet, Air	1
4	10260	• Assembly, Crossover Hose	1
5	80270	• Screw, Phillister Head Long	4
6	10045	• Weldment, 2 Inch Solid Goose Neck	1
7	60010	• Plate, Pad Backup	1

DASH (-) ITEM NOT ILLUSTRATED

REVISION:



1-1/2 INCH SOLID STANDARD
PAD BACKUP ASSEMBLY

LOVA
PARTS
GROUP 40
FIGURE 11
PAGE 01

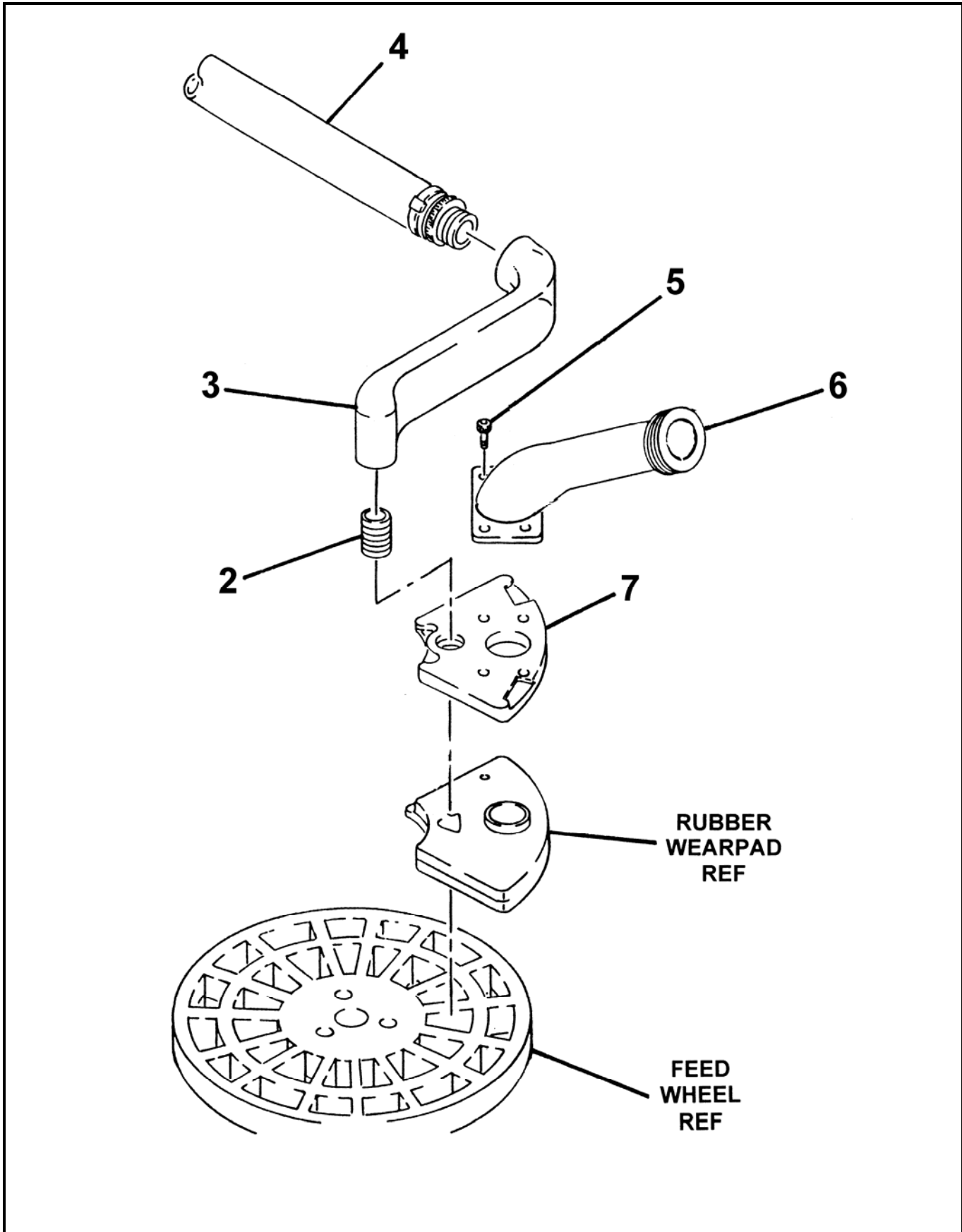

REVISION:



1-1/2 INCH SOLID STANDARD
PAD BACKUP ASSEMBLY

LOVA
PARTS
GROUP 40
FIGURE 11
PAGE 02

ITEM NO.	REED'S PARTS NO.	DESCRIPTION	QTY
		1 2 3 4 5	
-1	10662	Assembly, 1-1/2 Inch Solid Standard Pad Backup (See Group 70, Figure 07 for NHA)	Ref
2	10232	• Nipple	1
3	10219	• Inlet, Air	1
4	10260	• Assembly, Crossover Hose	1
5	80270	• Screw, Phillister Head Long	4
6	10044	• Weldment, 1-1/2 Inch Solid Goose Neck	1
7	60012	• Plate, Pad Backup	1

DASH (-) ITEM NOT ILLUSTRATED

REVISION:



MODEL LOVA PNEUMATIC SPRAYING MACHINE
ILLUSTRATED PARTS MANUAL

LOVA
PARTS
GROUP 40
FIGURE 12
PAGE 01

THIS PAGE INTENTIONALLY LEFT BLANK.

REVISION:

REED PNEUMATIC SPRAYING MACHINE MODEL LOVA™ SERIES 4 ILLUSTRATED PARTS MANUAL GROUP 50 AIR INLET INSTALLATION CONTAINS THE FOLLOWING FIGURES:

FIGURE 00	TABLE OF CONTENTS
FIGURE 01	8 AM AIR INLET INSTALLATION
FIGURE 02	8 AM AIR INLET INSTALLATION FOR REFRACTORY HOPPER
FIGURE 03	16 AM AIR INLET INSTALLATION
FIGURE 04	16 AM AIR INLET INSTALLATION FOR REFRACTORY HOPPER
FIGURE 05	8 AM AIR MOTOR ASSEMBLY
FIGURE 06	16 AM AIR MOTOR ASSEMBLY
FIGURE 07	8 AM AIR INLET ASSEMBLY
FIGURE 08	8 AM AIR INLET ASSEMBLY FOR REFRACTORY HOPPER
FIGURE 09	16 AM AIR INLET ASSEMBLY
FIGURE 10	16 AM AIR INLET ASSEMBLY FOR REFRACTORY HOPPER

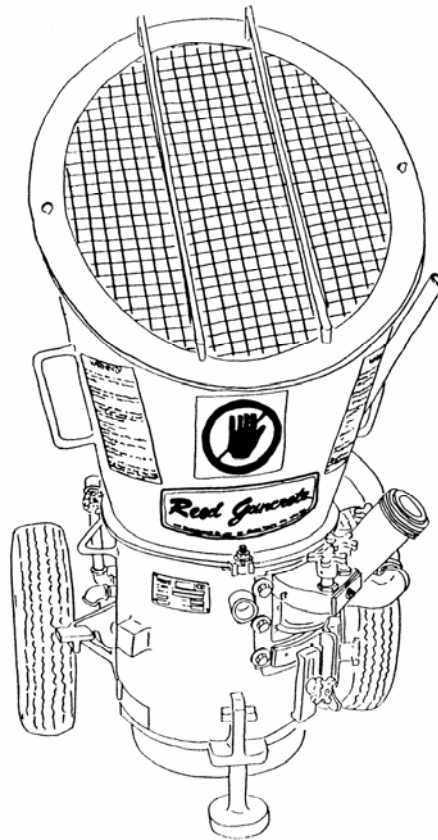

**SHOWN MODEL: LOVA™ SERIES 4
8 AM SHORT PREMIX HOPPER**



8 AM AIR INLET INSTALLATION

LOVA
PARTS
GROUP 50
FIGURE 01
PAGE 01

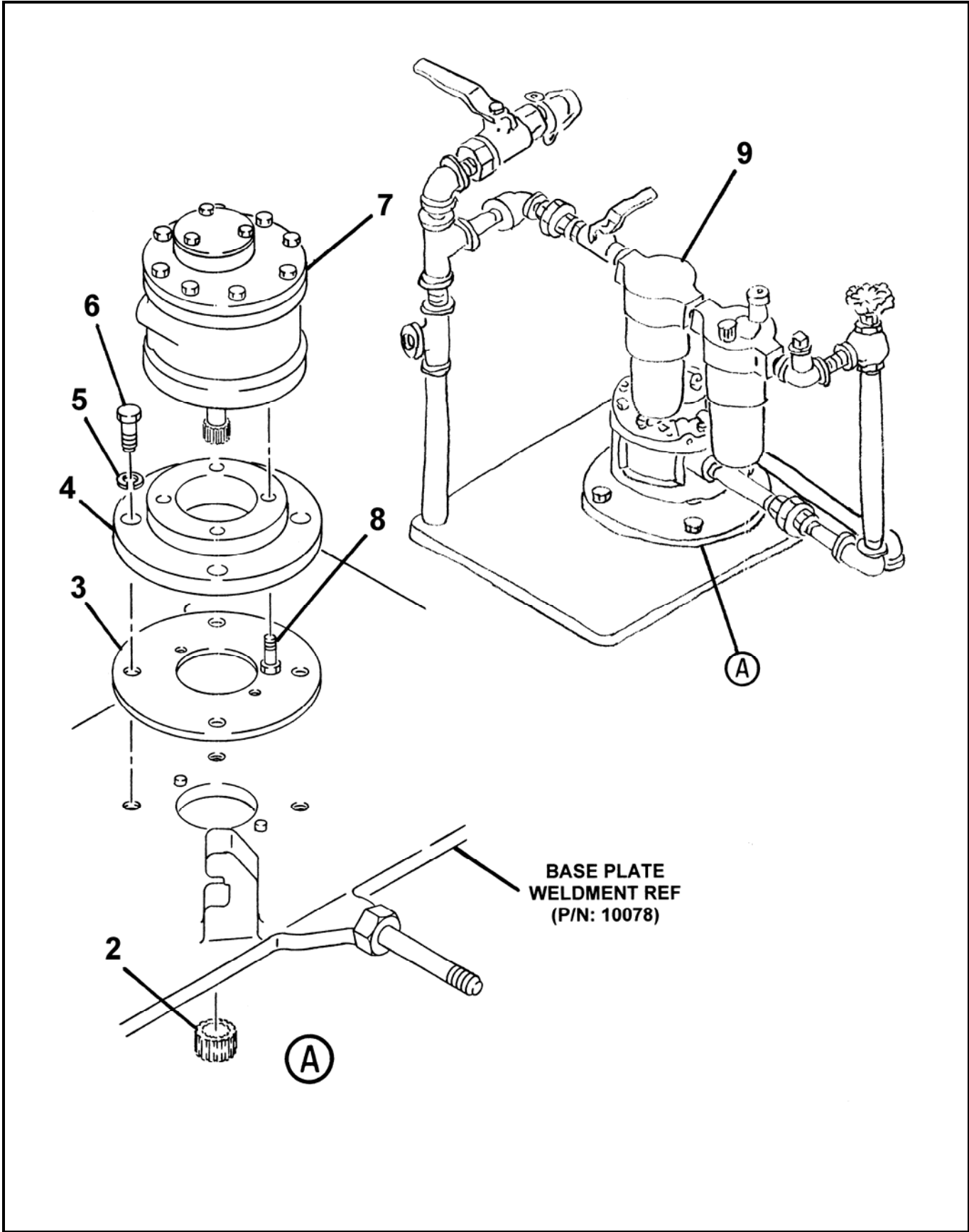

REVISION:



8 AM AIR INLET INSTALLATION

LOVA
PARTS
GROUP 50
FIGURE 01
PAGE 02

ITEM NO.	REED'S PARTS NO.	DESCRIPTION	QTY
		1 2 3 4 5	
-1	50-01	Installation, 8 AM Air Inlet (See Group 10, Figure 01, 02 and 03 for NHA)	Ref
2	10063	• Gear, Drive Motor	1
3	10037	• Gasket, Adapter Ring	1
4	10038	• Plate, Air Motor Adapter	1
5	80074	• Washer, Lock	4
6	80151	• Bolt, Hex	4
7	10600	• Assembly, 8 AM Air Motor (See Group 50, Figure 05 for DET)	1
8	80250	• Screw, Socket	4
9	10081	• Assembly, 8 AM Air Inlet (See Group 50, Figure 07 for DET)	1

DASH (-) ITEM NOT ILLUSTRATED

REVISION:



8 AM AIR INLET INSTALLATION FOR REFRACTORY HOPPER

LOVA
PARTS
GROUP 50
FIGURE 02
PAGE 01

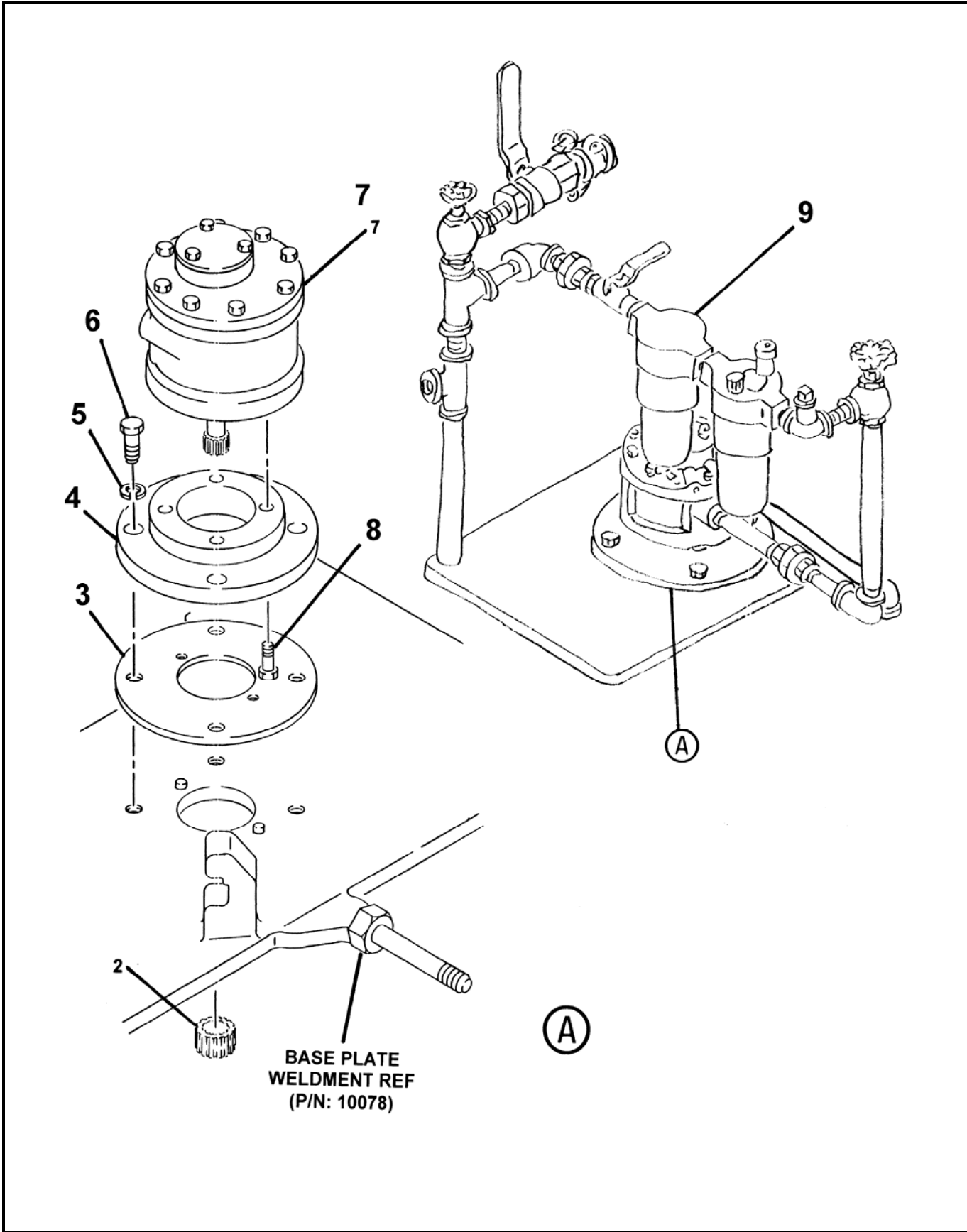

REVISION:



8 AM AIR INLET INSTALLATION
FOR REFRACTORY HOPPER

LOVA
PARTS
GROUP 50
FIGURE 02
PAGE 02

ITEM NO.	REED'S PARTS NO.	DESCRIPTION	QTY
		1 2 3 4 5	
-1	50-02	Installation, 8 AM Air Inlet For Refractory Hopper (See Group 10, Figure 04 for NHA)	Ref
2	10063	• Gear, Drive Motor	1
3	10037	• Gasket, Adapter Ring	1
4	10038	• Plate, Air Motor Adapter	1
5	80074	• Washer, Lock	4
6	80151	• Bolt, Hex	4
7	10600	• Assembly, 8 AM Air Motor (See Group 50, Figure 05 for DET)	1
8	80250	• Screw, Socket	4
9	10082	• Assembly, 8 AM Air Inlet For Refractory Hopper (See Group 50, Figure 08 for DET)	1

DASH (-) ITEM NOT ILLUSTRATED

REVISION:



16 AM AIR INLET INSTALLATION

LOVA
PARTS
GROUP 50
FIGURE 03
PAGE 01

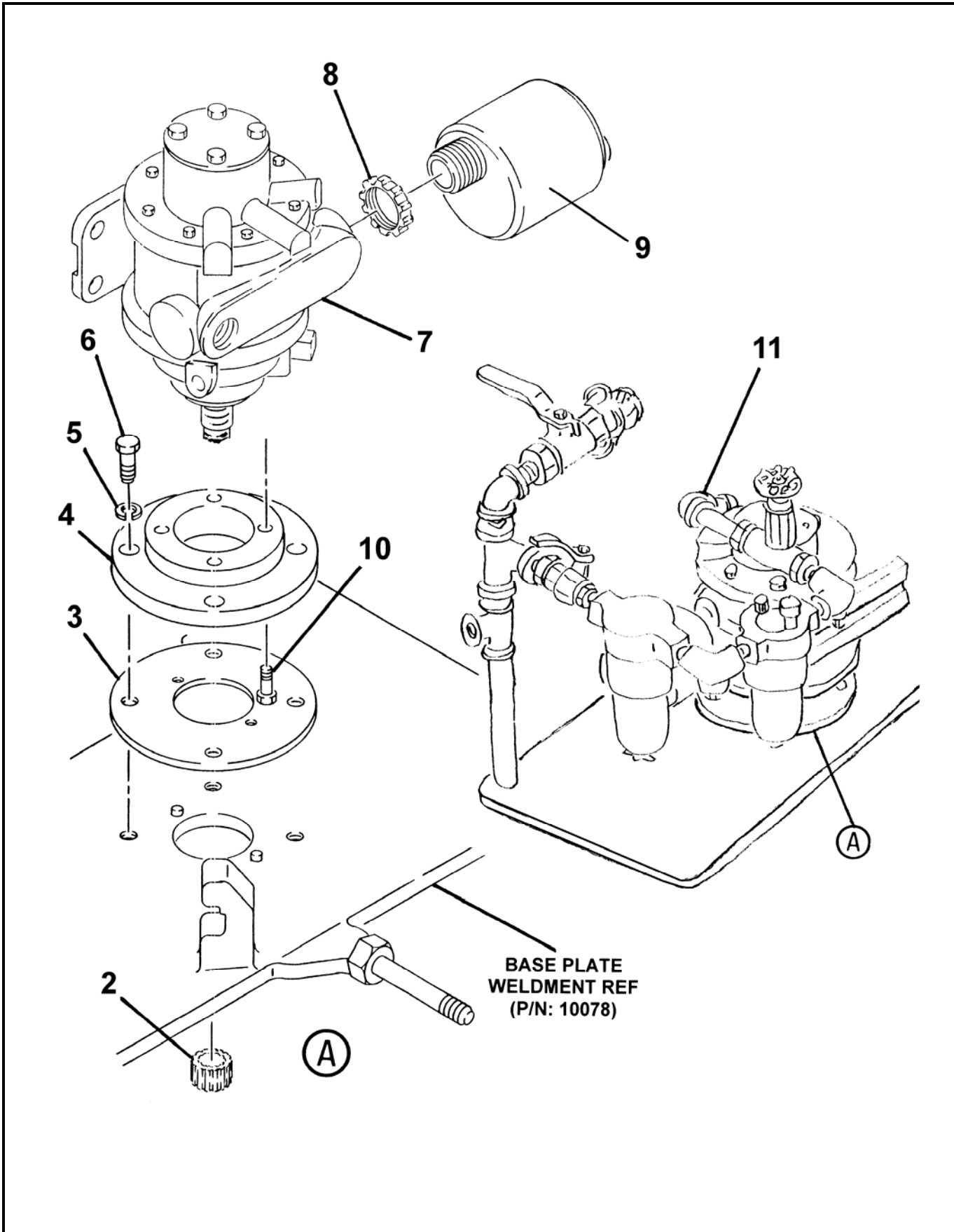

REVISION:



16 AM AIR INLET INSTALLATION

ITEM NO.	REED'S PARTS NO.	DESCRIPTION	QTY
		1 2 3 4 5	
-1	50-03	Installation, 16 AM Air Inlet (See Group 20, Figure 01, 02 and 03 for NHA)	Ref
2	10063	• Gear, Drive Motor	1
3	10036	• Gasket, Adapter Ring	1
4	10035	• Plate, Air Motor Adapter	1
5	80074	• Washer, Lock	4
6	80151	• Bolt, Hex	4
7	10603	• Assembly, 16 AM Air Motor (See Group 50, Figure 06 for DET)	1
8	10344	• Washer, Muffler Lock	1
9	10345	• Weldment, Muffler	1
10	80250	• Screw, Socket	4
11	10088	• Assembly, 16 AM Air Inlet (See Group 50, Figure 09 for DET)	1

DASH (-) ITEM NOT ILLUSTRATED



16 AM AIR INLET INSTALLATION
FOR REFRACTORY HOPPER

LOVA
PARTS
GROUP 50
FIGURE 04
PAGE 01

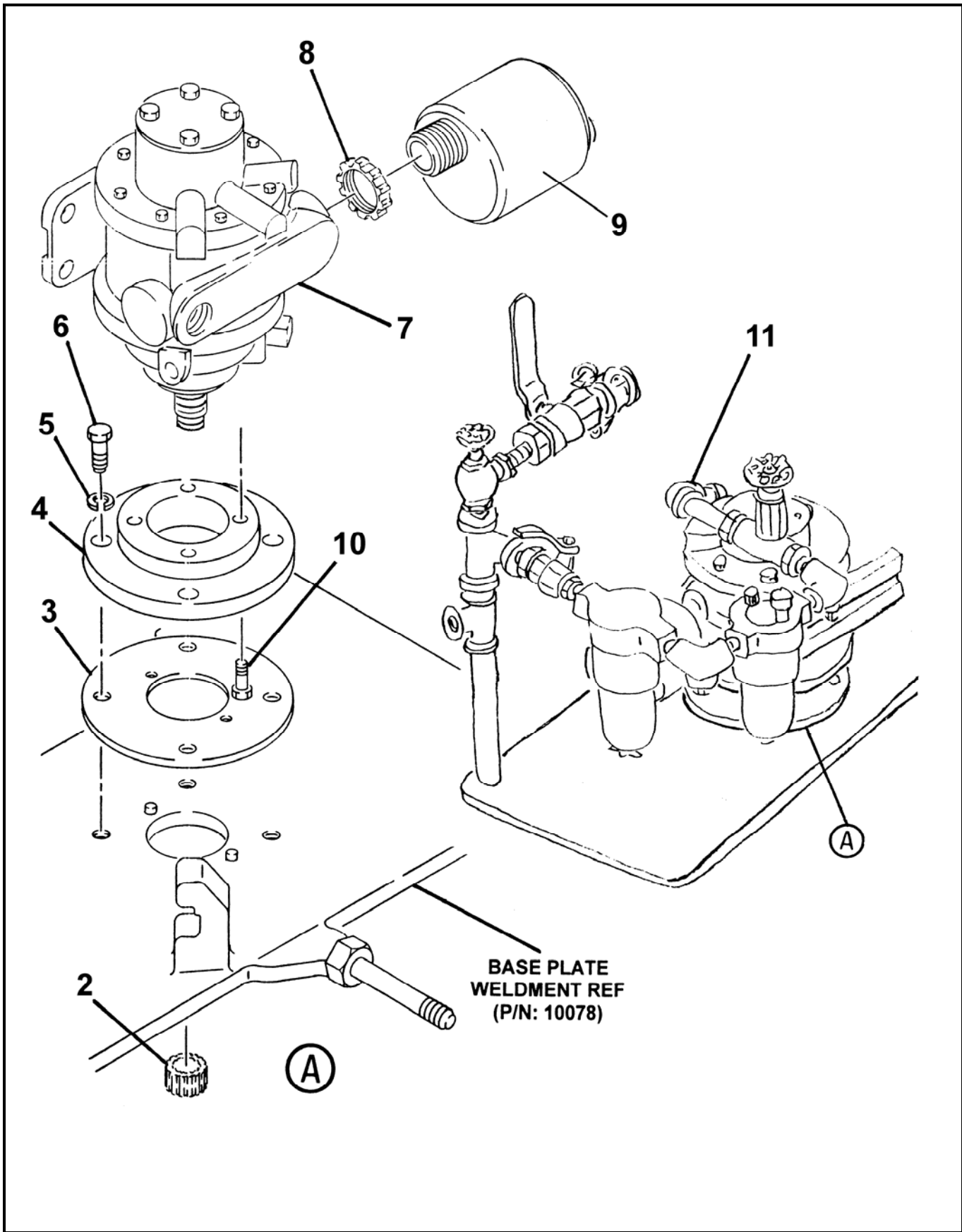

REVISION:



16 AM AIR INLET INSTALLATION
FOR REFRACTORY HOPPER

LOVA
PARTS
GROUP 50
FIGURE 04
PAGE 02

ITEM NO.	REED'S PARTS NO.	DESCRIPTION	QTY
		1 2 3 4 5	
-1	50-04	Installation, 16 AM Air Inlet For Refractory Hopper (See Group 10, Figure 04 for NHA)	Ref
2	10063	• Gear, Drive Motor	1
3	10036	• Gasket, Adapter Ring	1
4	10035	• Plate, Air Motor Adapter	1
5	80074	• Washer, Lock	4
6	80151	• Bolt, Hex	4
7	10603	• Assembly, 16 AM Air Motor (See Group 50, Figure 06 for DET)	1
8	10344	• Washer, Muffler Lock	1
9	10345	• Weldment, Muffler	1
10	80250	• Screw, Socket	4
11	10084	• Assembly, 16 AM Air Inlet For Refractory Hopper (See Group 50, Figure 10 for DET)	1

DASH (-) ITEM NOT ILLUSTRATED

REVISION:

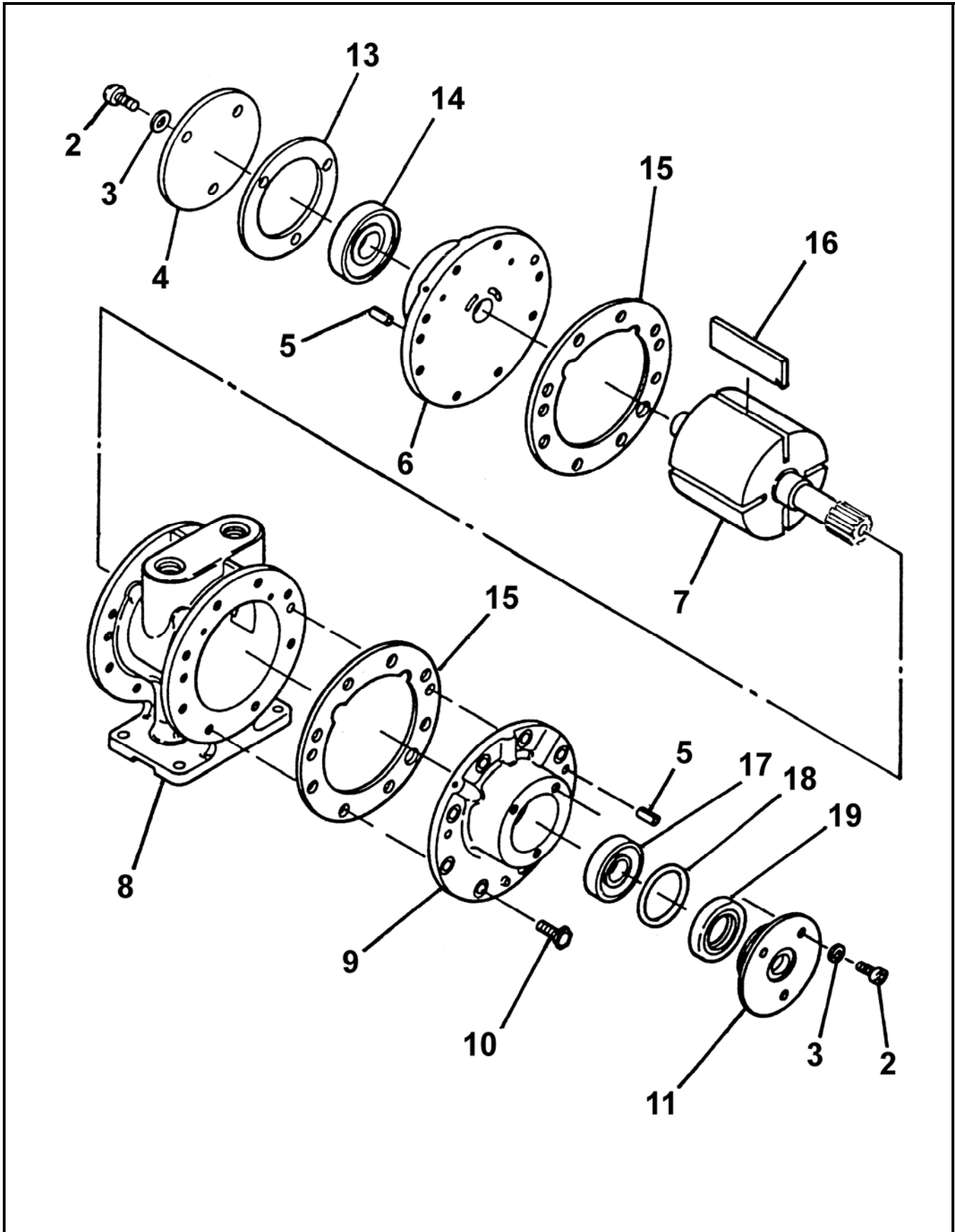

REVISION:



8 AM AIR MOTOR ASSEMBLY

LOVA
PARTS
GROUP 50
FIGURE 05
PAGE 02

ITEM NO.	REED'S PARTS NO.	DESCRIPTION	QTY
		1 2 3 4 5	
-1	10600	Assembly, 8 AM Air Motor (See Group 50, Figure 01 and 02 for NHA)	Ref
2		• Screw, Cap	6
3		• Washer, Lock	6
4		• Cap, Dead End	1
5		• Pin, Dowel	4
6		• Plate, Dead End	1
7		• Assembly, Rotor	1
8		• Body, Air Motor	1
9		• Plate, Drive End	1
10		• Bolt, Hex	8
11		• Cap, Drive End	1
-12	10605	• Kit, Repair	1
13		• • Gasket, Dead End Cap	1
14		• • Bearing, Dead End	1
15	10601	• • Gasket, Body Spacer	2
16	10602	• • Vane	4
17		• • Bearing, Drive End	1
18		• • O-Ring	1
19		• • Seal, Shaft	1

DASH (-) ITEM NOT ILLUSTRATED

REVISION:



16 AM AIR MOTOR ASSEMBLY

LOVA
PARTS
GROUP 50
FIGURE 06
PAGE 01

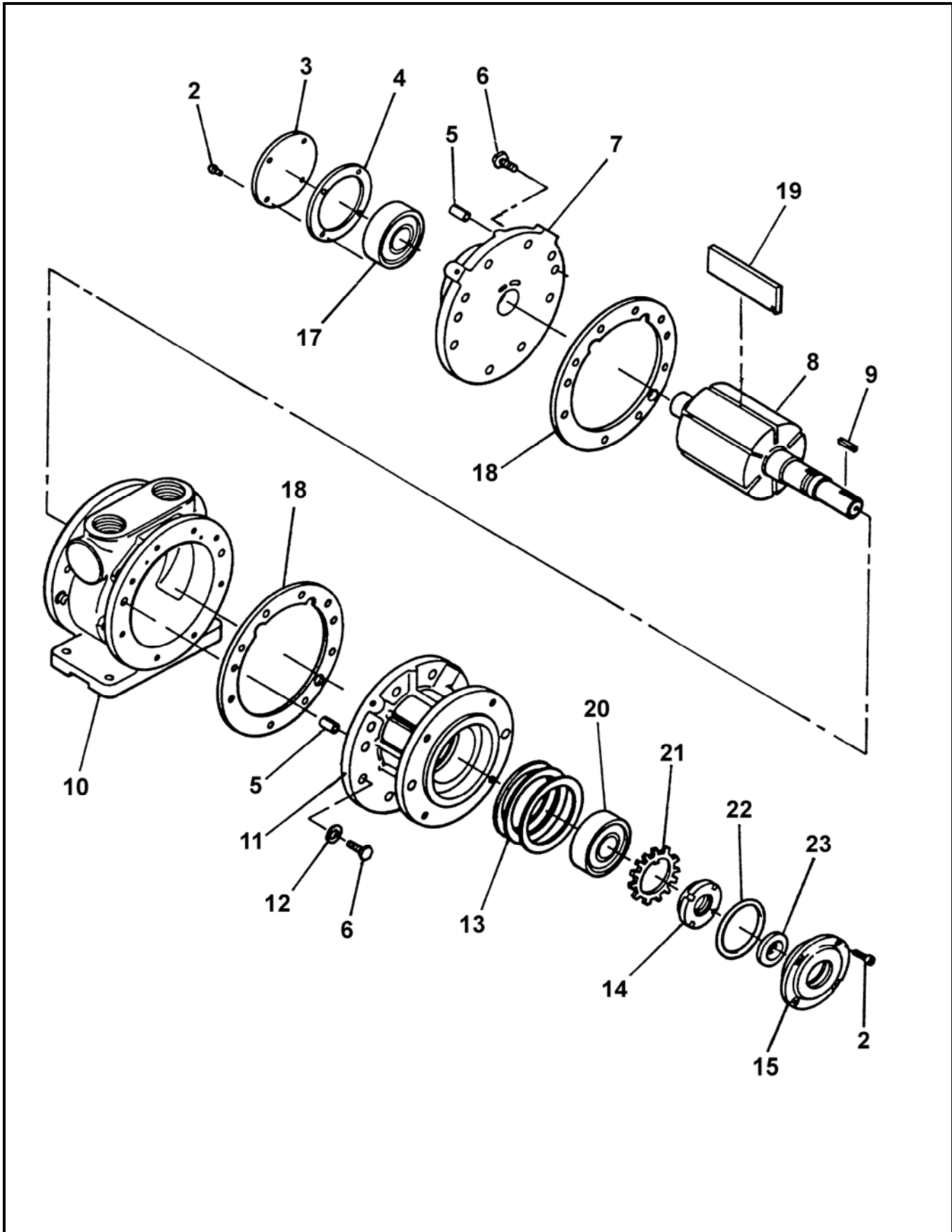

REVISION:



16 AM AIR MOTOR ASSEMBLY

LOVA
PARTS
GROUP 50
FIGURE 06
PAGE 02

ITEM NO.	REED'S PARTS NO.	DESCRIPTION	QTY
		1 2 3 4 5	
-1	10603	Assembly, 16 AM Air Motor (See Group 50, Figure 03 and 04 for NHA)	Ref
2		• Screw, Cap	8
3		• Cap, Dead End	1
4		• Gasket, End Cap	1
5		• Pin, Dowel	4
6		• Bolt, End Plate	16
7		• Plate, Dead End	1
8		• Assembly, Rotor	1
9		• Key, Drive (Optional)	1
10		• Body, Air Motor	1
11		• Plate, Drive End	1
12		• Washer	8
13		• Spacer	1
14		• Nut, Lock	1
15		• Cap, Drive End	1
-16	10606	• Kit, Optional Repair	1
17		• • Bearing, Dead End	1
18	10608	• • Gasket, Body Spacer	2
19	10604	• • Vane	6
20		• • Bearing, Drive End	1
21		• • Washer, Lock	1
22		• • O-Ring	1
23		• • Seal	1

DASH (-) ITEM NOT ILLUSTRATED



8 AM AIR INLET ASSEMBLY

LOVA
PARTS
GROUP 50
FIGURE 07
PAGE 01

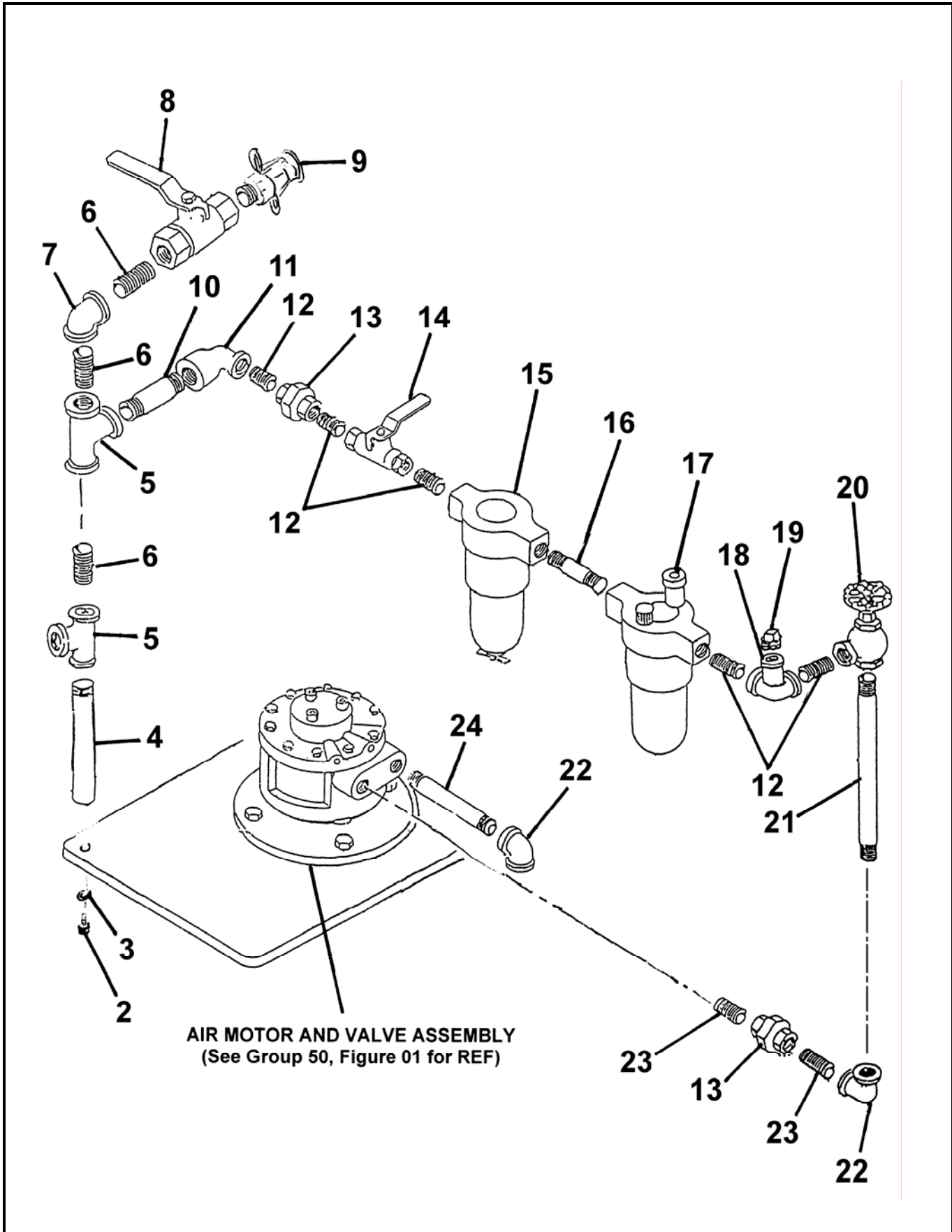

REVISION:



8 AM AIR INLET ASSEMBLY

LOVA
PARTS
GROUP 50
FIGURE 07
PAGE 02

ITEM NO.	REED'S PARTS NO.	DESCRIPTION					QTY
		1	2	3	4	5	
-1	10081	Assembly, 8 AM Air Inlet (See Group 50, Figure 01 for NHA)					Ref
2		• Bolt, Cap Hex					1
3		• Washer, SPL Lock					1
4	10002	• Support, Air Inlet					1
5	10299	• Tee					2
6	10265	• Nipple, Close					3
7	10304	• Elbow					1
8	10290	• Valve, Air Control					1
9	10948	• Coupling, Cam / Groove					1
10	10210	• Nipple					1
11	10237	• Reducer					1
12	10268	• Nipple, Close					5
13	10271	• Union					2
14	10270	• Valve, Ball					1
15	10320	• Filter, 8 AM Air					1
16	10267	• Nipple					1
17	10322	• Assembly, 8 AM Air Motor Lubricator					1
-17A	10330	• • Kit, Lubricator Repair					1
18	10291	• Elbow					1
19	10297	• Plug					1
20	12050	• Valve, Air / Water					1
21	20121	• Nipple					1
22	10269	• Elbow					2
23	10274	• Nipple					2
24	10222	• Nipple					1

DASH (-) ITEM NOT ILLUSTRATED

REVISION:



2

8 AM AIR INLET ASSEMBLY FOR REFRACTORY HOPPER

LOVA
PARTS
GROUP 50
FIGURE 08
PAGE 01

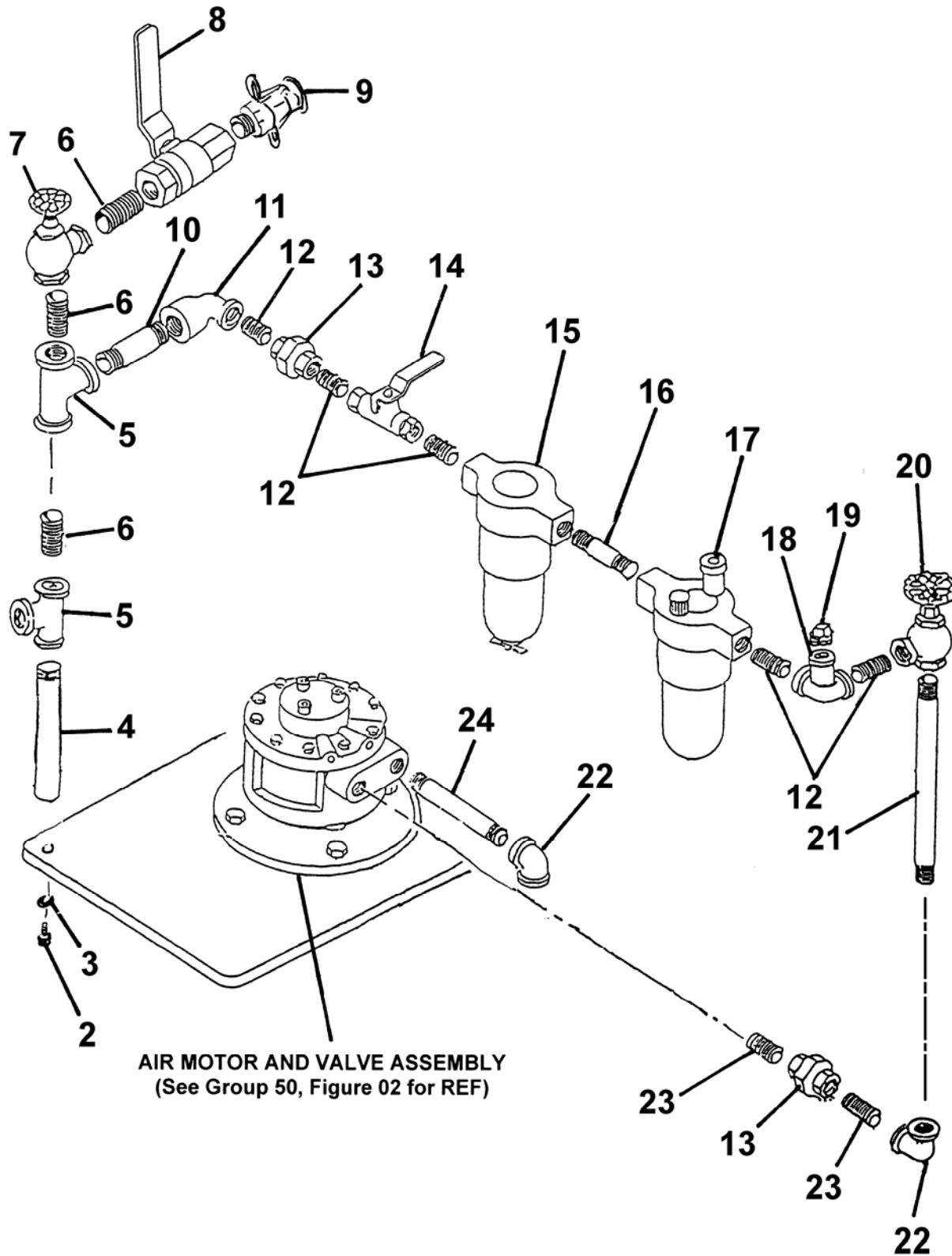

AIR MOTOR AND VALVE ASSEMBLY
(See Group 50, Figure 02 for REF)

REVISION:



8 AM AIR INLET ASSEMBLY
FOR REFRACTORY HOPPER

LOVA
PARTS
GROUP 50
FIGURE 08
PAGE 02

ITEM NO.	REED'S PARTS NO.	DESCRIPTION	QTY
		1 2 3 4 5	
-1	10082	Assembly, 8 AM Air Inlet for Refractory Hopper (See Group 50, Figure 02 for NHA)	Ref
2		• Bolt, Cap Hex	1
3		• Washer, SPL Lock	1
4	10002	• Support, Air Inlet	1
5	10299	• Tee	2
6	10265	• Nipple, Close	3
7	10295	• Valve, Brass	1
8	10290	• Valve, Air Control	1
9	10948	• Coupling, Cam / Groove	1
10	10210	• Nipple	1
11	10237	• Reducer	1
12	10268	• Nipple, Close	5
13	10271	• Union	2
14	10270	• Valve, Ball	1
15	10320	• Filter, 8 AM Air	1
16	10267	• Nipple	1
17	10322	• Assembly, 8 AM Air Motor Lubricator	1
-17A	10330	• • Kit, Lubricator Repair	1
18	10291	• Elbow	1
19	10297	• Plug	1
20	12050	• Valve, Air / Water	1
21	20121	• Nipple	1
22	10269	• Elbow	2
23	10274	• Nipple	2
24	10222	• Nipple	1

DASH (-) ITEM NOT ILLUSTRATED

REVISION:

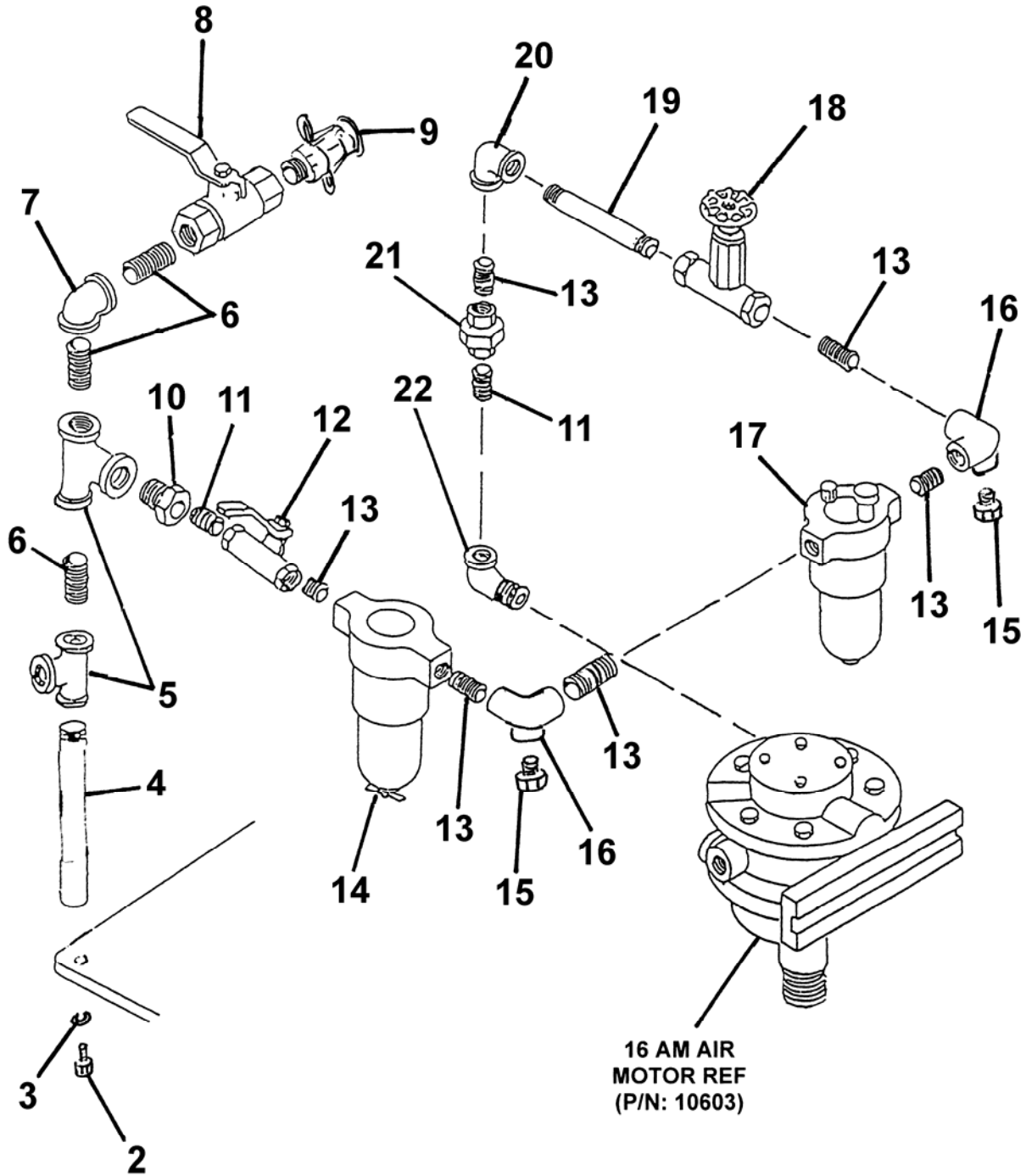



16 AM AIR INLET ASSEMBLY

LOVA
PARTS
GROUP 50
FIGURE 09
PAGE 02

ITEM NO.	REED'S PARTS NO.	DESCRIPTION	QTY
		1 2 3 4 5	
-1	10088	Assembly, 16 AM Air Inlet (See Group 50, Figure 03 for NHA)	Ref
2		• Bolt, Cap Hex	1
3		• Washer, SPL Lock	1
4	10002	• Support, Air Inlet	1
5	10299	• Tee	2
6	10265	• Nipple, Close	3
7	10304	• Elbow	1
8	10290	• Valve, Air Control	1
9	10948	• Coupling, Cam / Groove	1
10	10231	• Bushing, Hex	1
11	10286	• Nipple	2
12	10281	• Valve, Motor ON	1
13	10279	• Nipple, Close	6
14	10323	• Filter, 16 AM Air	1
15	10282	• Plug, Pipe	2
16	10283	• Elbow	2
17	10325	• Assembly, 16 AM Air Motor Lubricator	1
18	10284	• Valve, Motor	1
19	10351	• Nipple	1
20	10278	• Elbow	1
21	10285	• Union	1
22	10218	• Valve, Street	1

DASH (-) ITEM NOT ILLUSTRATED

REVISION:



16 AM AIR INLET ASSEMBLY
FOR REFRACTORY HOPPER

LOVA
PARTS
GROUP 50
FIGURE 10
PAGE 01

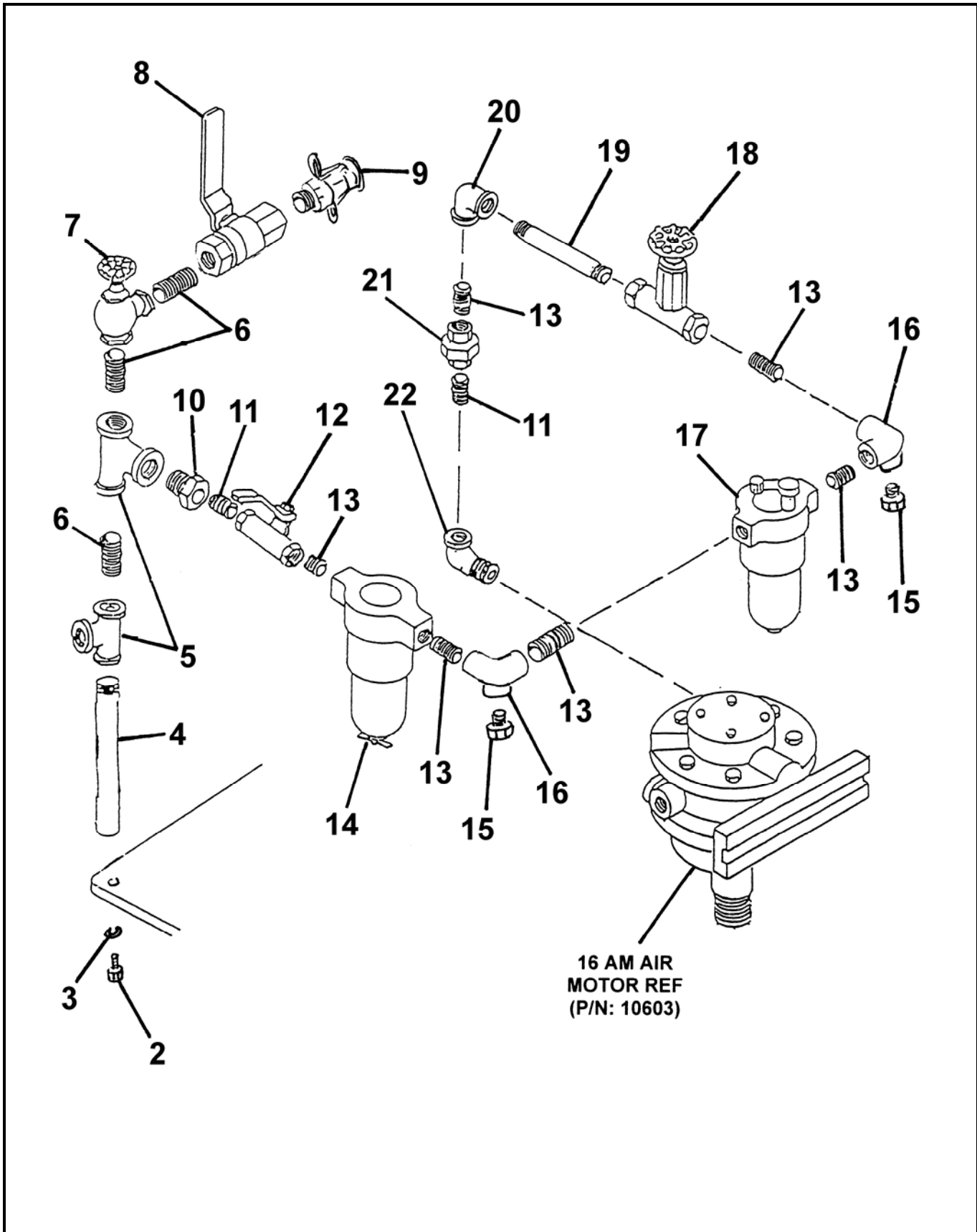

REVISION:



16 AM AIR INLET ASSEMBLY
FOR REFRACTORY HOPPER

LOVA
PARTS
GROUP 50
FIGURE 10
PAGE 02

ITEM NO.	REED'S PARTS NO.	DESCRIPTION	QTY
		1 2 3 4 5	
-1	10084	Assembly, 16 AM Air Inlet for Refractory Hopper (See Group 50, Figure 04 for NHA)	Ref
2		• Bolt, Cap Hex	1
3		• Washer, SPL Lock	1
4	10002	• Support, Air Inlet	1
5	10299	• Tee	2
6	10265	• Nipple, Close	3
7	10295	• Valve, Brass	1
8	10290	• Valve, Air Control	1
9	10948	• Coupling, Cam / Groove	1
10	10231	• Bushing, Hex	1
11	10286	• Nipple	2
12	10281	• Valve, Motor ON	1
13	10279	• Nipple, Close	6
14	10323	• Filter, 16 AM Air	1
15	10282	• Plug, Pipe	2
16	10283	• Elbow	2
17	10325	• Assembly, 16 AM Air Motor Lubricator	1
18	10284	• Valve, Motor	1
19	10351	• Nipple	1
20	10278	• Elbow	1
21	10285	• Union	1
22	10218	• Valve, Street	1

DASH (-) ITEM NOT ILLUSTRATED

REVISION:



MODEL LOVA PNEUMATIC SPRAYING MACHINE
ILLUSTRATED PARTS MANUAL

LOVA
PARTS
GROUP 50
FIGURE 11
PAGE 01

THIS PAGE INTENTIONALLY LEFT BLANK.



MODEL LOVA PNEUMATIC SPRAYING MACHINE
GROUP 60 ACCESSORIES INSTALLATION

LOVA
PARTS
GROUP 60
FIGURE 00
PAGE 01

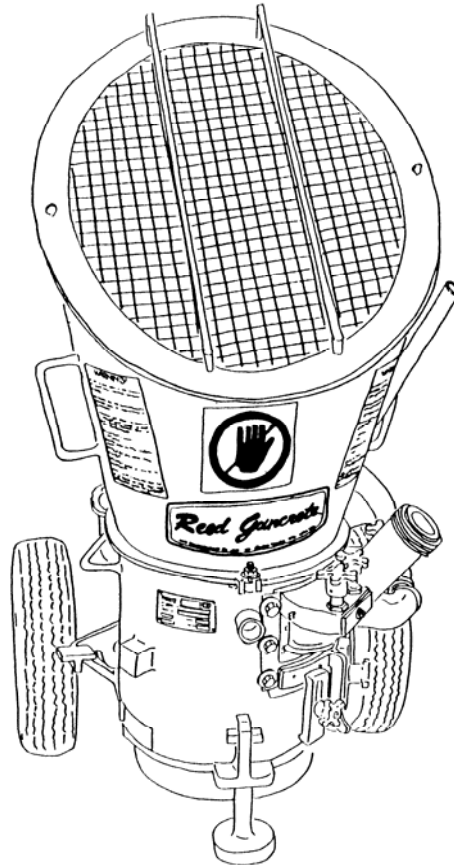

SHOWN MODEL: LOVA™ SERIES IV
16 AM STANDARD HOPPER

REED PNEUMATIC SPRAYING MACHINE MODEL LOVA™ SERIES 4 ILLUSTRATED PARTS MANUAL GROUP 60 ACCESSORIES INSTALLATION CONTAINS THE FOLLOWING FIGURES:

- FIGURE 00** TABLE OF CONTENTS
- FIGURE 01** ACCESSORIES INSTALLATION

REVISION:



ACCESSORIES INSTALLATION

LOVA
PARTS
GROUP 60
FIGURE 01
PAGE 01

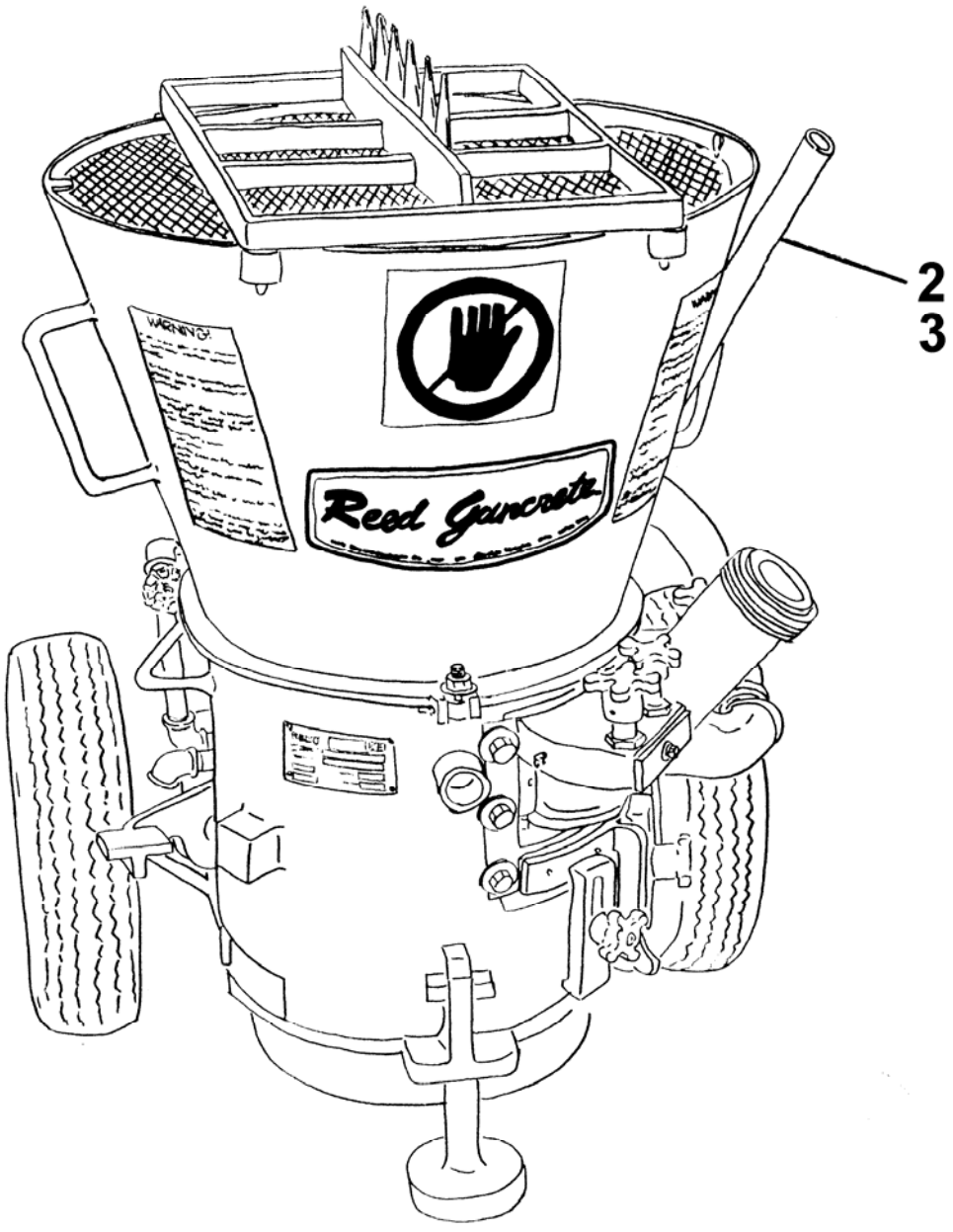

**SHOWN MODEL: LOVA™ SERIES IV
8 AM REFRACTORY HOPPER**

REVISION:



ACCESSORIES INSTALLATION

LOVA
PARTS
GROUP 60
FIGURE 01
PAGE 02

ITEM NO.	REED'S PARTS NO.	DESCRIPTION					QTY
		1	2	3	4	5	
-1	60-01	Installation, Accessories (See Group 10, Figure 01, 02, 03, 04, Group 20, Figure 01, 02, 03 and 04 for NHA)					Ref
2	10914	• Handle, 35 Inch					1
3	10899	• Glip, Handle					1

DASH (-) ITEM NOT ILLUSTRATED

REVISION:



**MODEL LOVA PNEUMATIC SPRAYING MACHINE
ILLUSTRATED PARTS MANUAL**

**LOVA
PARTS**
GROUP 60
FIGURE 02
PAGE 01

THIS PAGE INTENTIONALLY LEFT BLANK.

REVISION:

REED PNEUMATIC SPRAYING MACHINE MODEL LOVA™ SERIES 4 ILLUSTRATED PARTS MANUAL GROUP 70 OPTIONAL INSTALLATION CONTAINS THE FOLLOWING FIGURES:

- FIGURE 00** TABLE OF CONTENTS
- FIGURE 01** OPTIONAL INSTALLATION
- FIGURE 02** BULK BAG ADAPTER ASSEMBLY
- FIGURE 03** 12 POCKET DIVIDERLESS FEED WHEEL
AND PAD BACKUP INSTALLATION
- FIGURE 04** STANDARD 15 POCKET FEED WHEEL
AND PAD BACKUP INSTALLATION
- FIGURE 05** 15 POCKET LARGE AGGREGATE WITH DIVIDER FEED WHEEL
AND PAD BACKUP INSTALLATION
- FIGURE 06** 15 POCKET LARGE AGGREGATE DIVIDERLESS FEED WHEEL
AND PAD BACKUP INSTALLATION
- FIGURE 07** 20 POCKET FEED WHEEL
AND PAD BACKUP INSTALLATION
- FIGURE 08** 21 POCKET FEED WHEEL
AND PAD BACKUP INSTALLATION
- FIGURE 09** 30 POCKET FEED WHEEL
AND PAD BACKUP INSTALLATION
- FIGURE 10** 1-1/4 INCH SOLID PAD BACKUP ASSEMBLY
- FIGURE 11** 1-1/2 INCH SOLID PAD BACKUP ASSEMBLY
- FIGURE 12** 2 INCH LINER TYPE STANDARD PAD BACKUP ASSEMBLY
- FIGURE 13** 2 INCH SOLID PAD BACKUP ASSEMBLY
- FIGURE 14** 2 INCH LINER TYPE LARGE AGGREGATE PAD BACKUP ASSEMBLY
- FIGURE 15** 1-1/2 INCH SOLID LARGE AGGREGATE PAD BACKUP ASSEMBLY
- FIGURE 16** 1-1/2 INCH LINER TYPE STANDARD PAD BACKUP ASSEMBLY
- FIGURE 17** 1-1/2 INCH LINER TYPE LARGE AGGREGATE
PAD BACKUP ASSEMBLY
- FIGURE 18** 2 INCH LINER TYPE LARGE AGGREGATE,
1-1/4 AIR INLET PAD BACKUP ASSEMBLY



OPTIONAL INSTALLATION

LOVA
PARTS
GROUP 70
FIGURE 01
PAGE 01

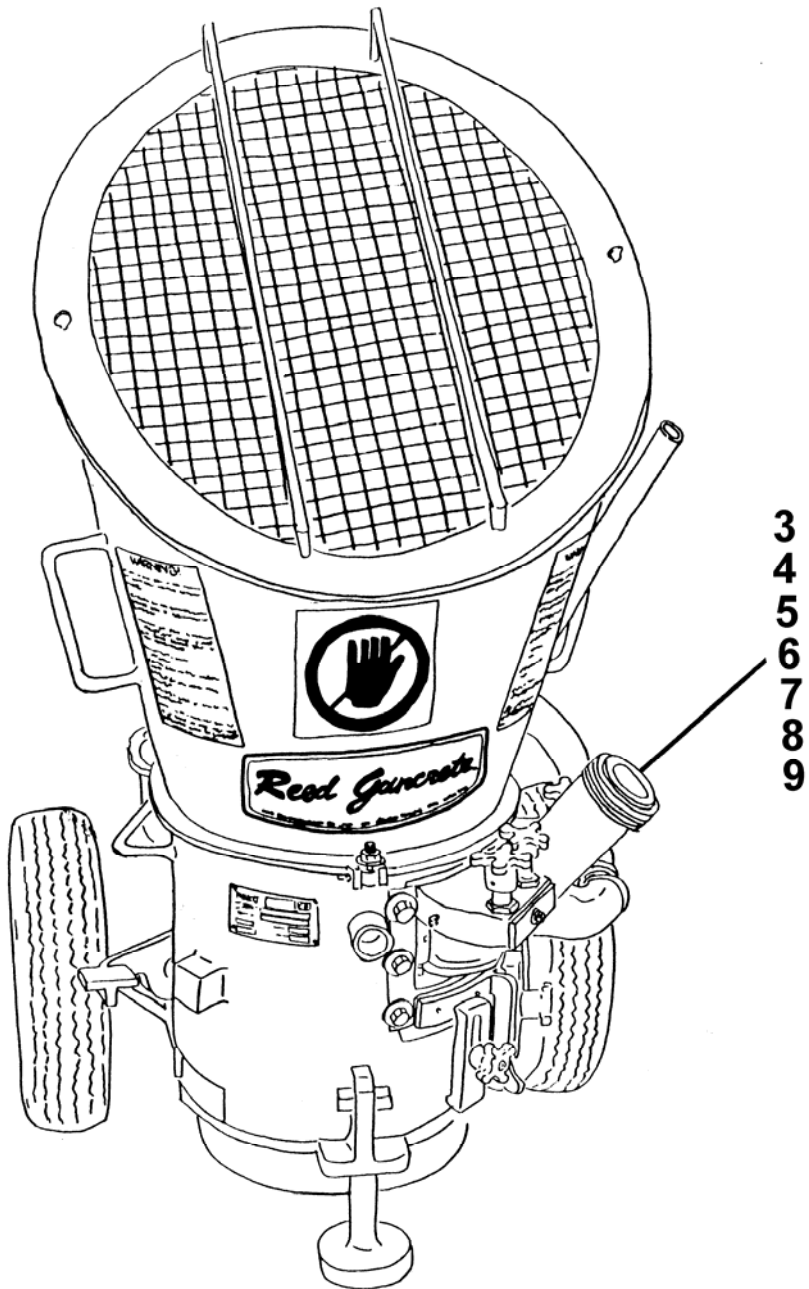

SHOWN MODEL: LOVA™ SERIES 4
16 AM SHORT PREMIX HOPPER

REVISION:



OPTIONAL INSTALLATION

ITEM NO.	REED'S PARTS NO.	DESCRIPTION	QTY
		1 2 3 4 5	
-1	70-01	Installation, Optional (See Group 10, Figure 01, 02, 03, 04., Group 20, Figure 01, 02, 03 and 04 for NHA)	Ref
-2	13245	• Assembly, Bulk Bag Adapter (Used on Refractory Hopper only) (See Group 70, Figure 19 for DET)	1
3	70-03	• Installation, 12 Pocket Dividerless Feed Wheel And Pad Backup (See Group 70, Figure 03 for DET)	1
4	70-04	• Installation, Standard 15 Pocket Feed Wheel And Pad Backup (See Group 70, Figure 04 for DET)	1
5	70-05	• Installation, 15 Pocket Large Aggregate With Divider Feed Wheel And Pad Backup (See Group 70, Figure 05 for DET)	1
6	70-06	• Installation, 15 Pocket Large Aggregate Dividerless Feed Wheel And Pad Backup (See Group 70, Figure 06 for DET)	1
7	70-07	• Installation, 20 Pocket Feed Wheel And Pad Backup (See Group 70, Figure 07 for DET)	1
8	70-08	• Installation, 21 Pocket Feed Wheel And Pad Backup (See Group 70, Figure 08 for DET)	1
9	70-09	• Installation, 30 Pocket Feed Wheel And Pad Backup (See Group 70, Figure 09 for DET)	1
-10	10670	• Assembly, 2 Inch Liner Type Large Aggregate and 1-1/4 Air Inlet Pad Backup (See Group 70, Figure 18 for DET)	1

DASH (-) ITEM NOT ILLUSTRATED

REVISION:



BULK BAG ADAPTER ASSEMBLY

LOVA
PARTS
GROUP 70
FIGURE 02
PAGE 01

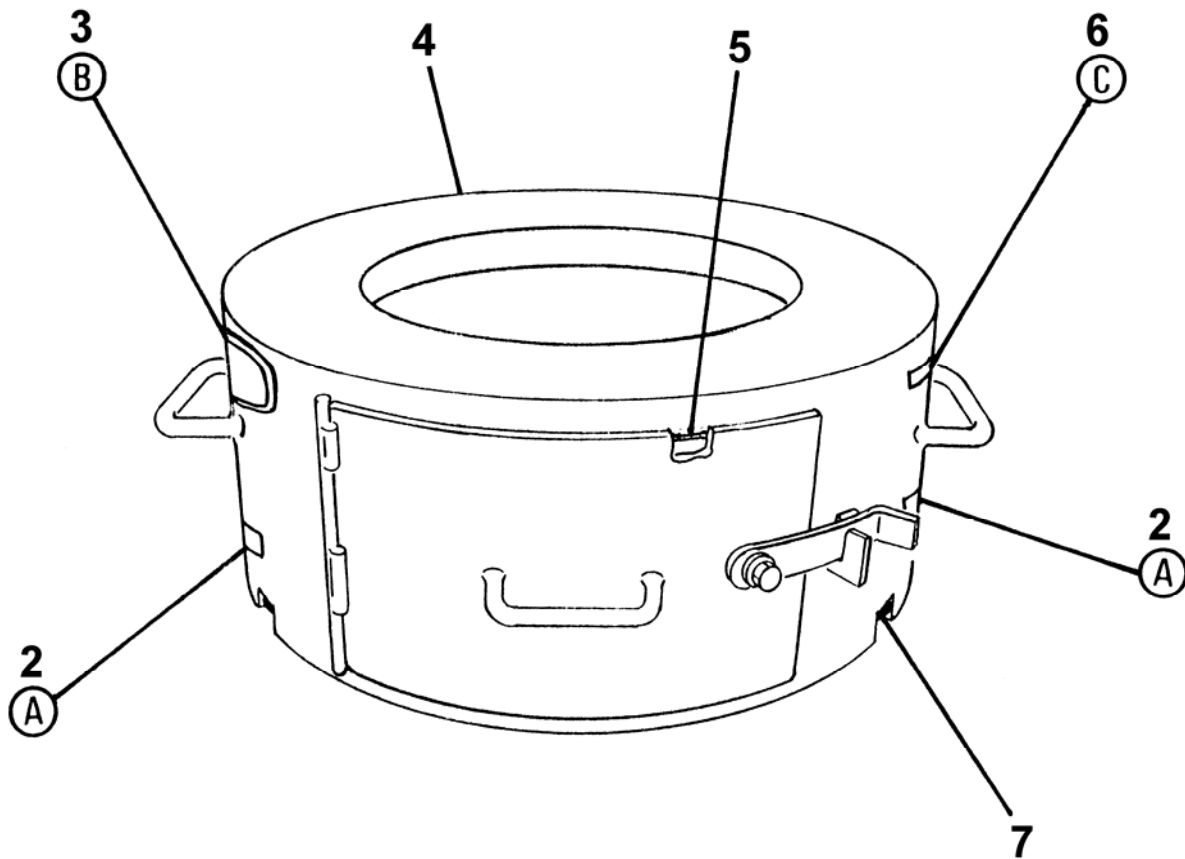

CAUTION DO NOT LIFT
THIS MACHINE BY HOPPER HANDLES.
USE SLINGS UNDER MACHINE.

(A)

2



BULKBAG ADAPTER ASSEMBLY

LOVA PARTS GROUP 70 FIGURE 02 PAGE 02



(B)

3

WARNING
ALWAYS WEAR SAFETY GLASSES
WHEN OPERATING THIS MACHINE

(C)

6

ITEM NO.	REED'S PARTS NO.	DESCRIPTION	QTY
		1 2 3 4 5	
-1	13245	Assembly, Bulk Bag Adapter (Used on Refractory Hopper only) (See Group 70, Figure 01 for NHA)	Ref
2	10842	• Decal, CAUTION , Do Not Lift this Machine by Hopper Handle	2
3	10833	• Decal, REED Guncrete	1
4	13180	• Adapter, Bulk Bag	1
5	13257	• Seal, Weather Strip 105 Inch	1
6	10838	• Decal, WARNING , Always Wear Safety Glasses when	1
7	13243	• Ring, Bottom Seal	1

DASH (-) ITEM NOT ILLUSTRATED



12 POCKET DIVIDERLESS FEED WHEEL AND PAD BACKUP INSTALLATION

LOVA
PARTS
GROUP 70
FIGURE 03
PAGE 01

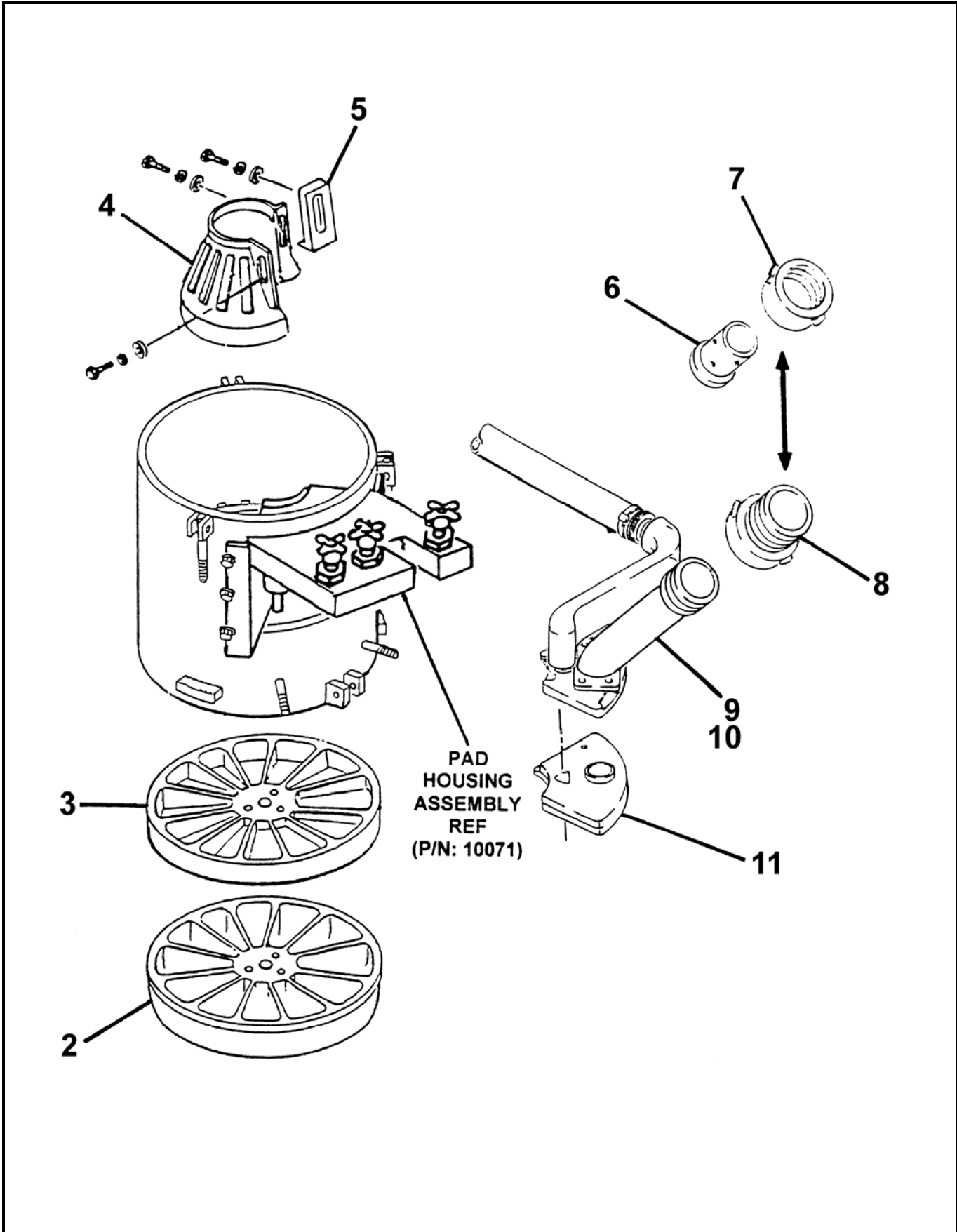

REVISION:



12 POCKET DIVIDERLESS FEED WHEEL
AND PAD BACKUP INSTALLATION

LOVA
PARTS
GROUP 70
FIGURE 03
PAGE 02

ITEM NO.	REED'S PARTS NO.	DESCRIPTION	QTY
		1 2 3 4 5	
-1	70-03	Installation, 12 Pocket Dividerless Feed Wheel and Pad Backup (See Group 70, Figure 01 for NHA)	Ref
2	10799	• Feed Bowl, 12 Pocket Dividerless	1
3	10798	• Plate, 12 Pocket Dividerless	1
4	10922	• Cone, Rock	1
5	10014	• Shear, Narrow Rock	1
6	11021	• End, Coarse 2 Inch Female Hose (Optional Item)	1
7	11033	• Nut, Coarse 2 Inch Coupling (Optional Item)	1
8	12087	• Adapter, 2 Inch to 2-1/2 Inch Goose Neck (Optional Item)	1
9	10665	• Assembly, 2 Inch Solid Large Aggregate Pad Backup (Optional Item) (See Group 40, Figure 10 for DET)	1
10	10666	• Assembly, 2 Inch Liner Type Large Aggregate Pad Backup (Optional Item) (See Group 70, Figure 14 for DET)	1
11	10336	• Wearpad, Rubber	1

DASH (-) ITEM NOT ILLUSTRATED

REVISION:



STANDARD 15 POCKET FEED WHEEL
AND PAD BACKUP INSTALLATION

LOVA
PARTS
GROUP 70
FIGURE 04
PAGE 01

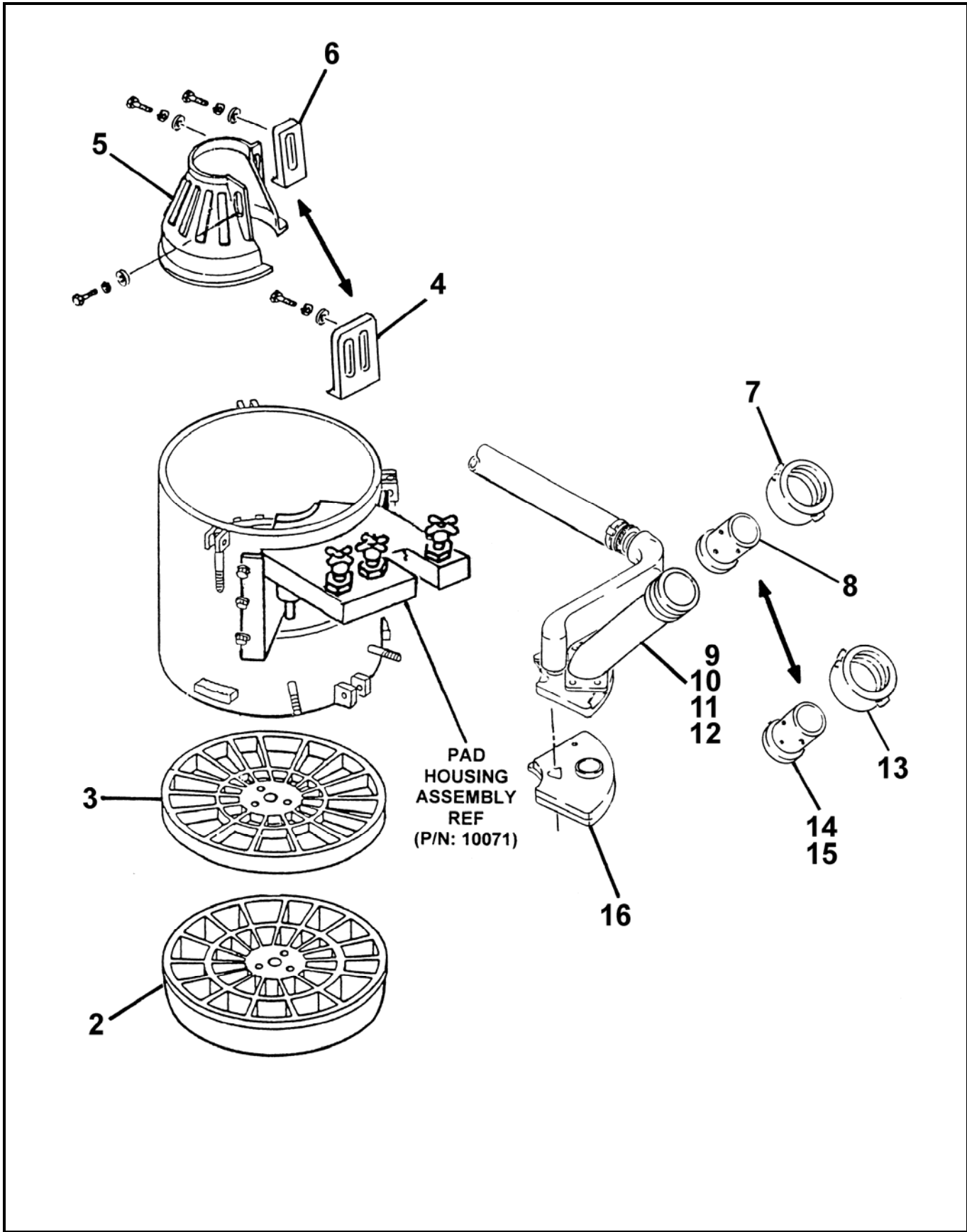

REVISION:



STANDARD 15 POCKET FEED WHEEL
AND PAD BACKUP INSTALLATION

LOVA
PARTS
GROUP 70
FIGURE 04
PAGE 02

ITEM NO.	REED'S PARTS NO.	DESCRIPTION	QTY
		1 2 3 4 5	
-1	70-04	Installation, Standard 15 Pocket Feed Wheel and Pad Backup (See Group 70, Figure 01 for NHA)	Ref
2	10801	• Feed Bowl, Standard 15 Pocket	1
3	10800	• Plate, Standard 15 Pocket Wear	1
4	10013	• Shear, Wide Rock (Optional Item)	1
5	10936	• Weldment, Refractory Cone (Optional Item)	1
6	10014	• Shear, Narrow Rock (Optional Item)	1
7	11033	• Nut, Coarse 2 Inch Coupling (Optional Item)	1
8	11021	• End, Coarse 2 Inch Female Hose (Optional Item)	1
9	10662	• Assembly, 1-1/2 Inch Solid Pad Backup (Optional Item) (See Group 70, Figure 11 for DET)	1
10	10663	• Assembly, 2 Inch Liner Type Standard Pad Backup (Optional Item) (See Group 70, Figure 12 for DET)	1
11	10664	• Assembly, 2 Inch Solid Pad Backup (Optional Item) (See Group 70, Figure 13 for DET)	1
12	10668	• Assembly, 1-1/2 Inch Liner Type standard Pad Backup (Optional Item) (See Group 70, Figure 16 for DET)	1
13	11037	• Nut, Coarse 1-1/2 Inch Coupling (Optional Item - used on P/N: 10668)	1
14	11018	• End, Coarse 1-1/2 Inch Female Hose (Optional Item - used on P/N: 10668)	1
15	11019	• End, Coarse 1-1/2 Inch Female Hose (Optional Item - used on P/N: 10668)	1
16	10338	• Wearpad, Rubber	1

DASH (-) ITEM NOT ILLUSTRATED

REVISION:



15 POCKET LARGE AGGREGATE
WITH DIVIDER FEED WHEEL
AND PAD BACKUP INSTALLATION

LOVA
PARTS
GROUP 70
FIGURE 05
PAGE 01

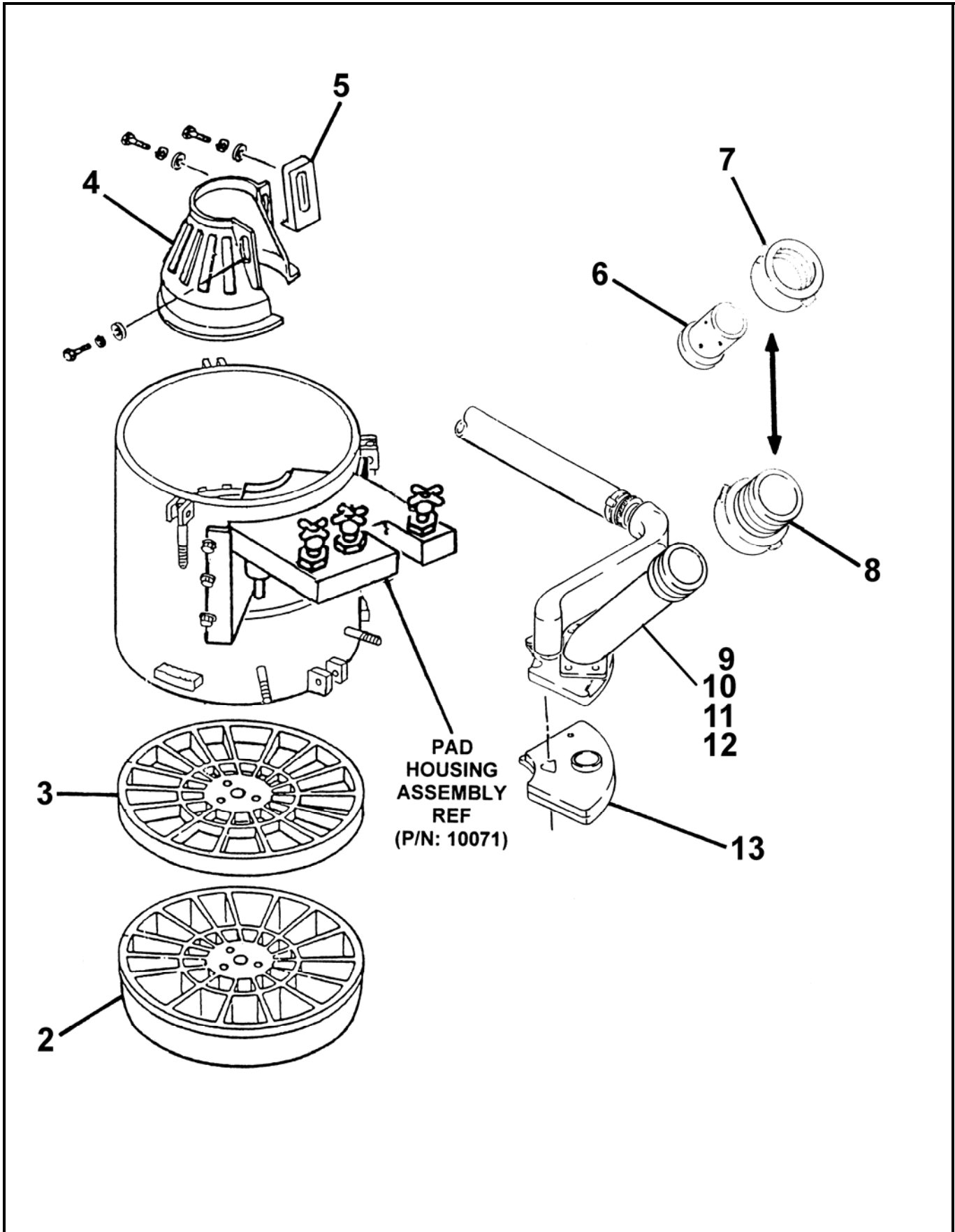

REVISION:



**15 POCKET LARGE AGGREGATE
WITH DIVIDER FEED WHEEL
AND PAD BACKUP INSTALLATION**

**LOVA
PARTS
GROUP 70
FIGURE 05
PAGE 02**

ITEM NO.	REED'S PARTS NO.	DESCRIPTION	QTY
		1 2 3 4 5	
-1	70-05	Installation, 15 Pocket Large Aggregate with Divider Feed Wheel and Pad Backup (See Group 70, Figure 01 for NHA)	Ref
2	10803	• Feed Bowl, 15 Pocket with Divider Large Aggregate	1
3	10802	• Plate, 15 Pocket Large Aggregate Wear	1
4	10922	• Cone, Rock	1
5	10014	• Shear, Narrow Rock	1
6	11021	• End, Coarse 2 Inch Female Hose (Optional Item)	1
7	11033	• Nut, Coarse 2 Inch Coupling (Optional Item)	1
8	12087	• Adapter, 2 Inch to 2-1/2 Inch Goose Neck (Optional Item)	1
9	10665	• Assembly, 2 Inch Solid Large Aggregate Pad Backup (Optional Item) (See Group 40, Figure 10 for DET)	1
10	10666	• Assembly, 2 Inch Liner Type Large Aggregate Pad Backup (Optional Item) (See Group 70, Figure 14 for DET)	1
11	10667	• Assembly, 1-1/2 Inch Solid Large Aggregate Pad Backup (Optional Item) (See Group 70, Figure 15 for DET)	1
12	10669	• Assembly, 1-1/2 Inch Liner Type Large Aggregate Pad Backup (Optional Item) (See Group 70, Figure 17 for DET)	1
13	10336	• Wearpad, Rubber	1

DASH (-) ITEM NOT ILLUSTRATED

REVISION:



15 POCKET LARGE AGGREGATE
DIVIDERLESS FEED WHEEL
AND PAD BACKUP INSTALLATION

LOVA
PARTS
GROUP 70
FIGURE 06
PAGE 01

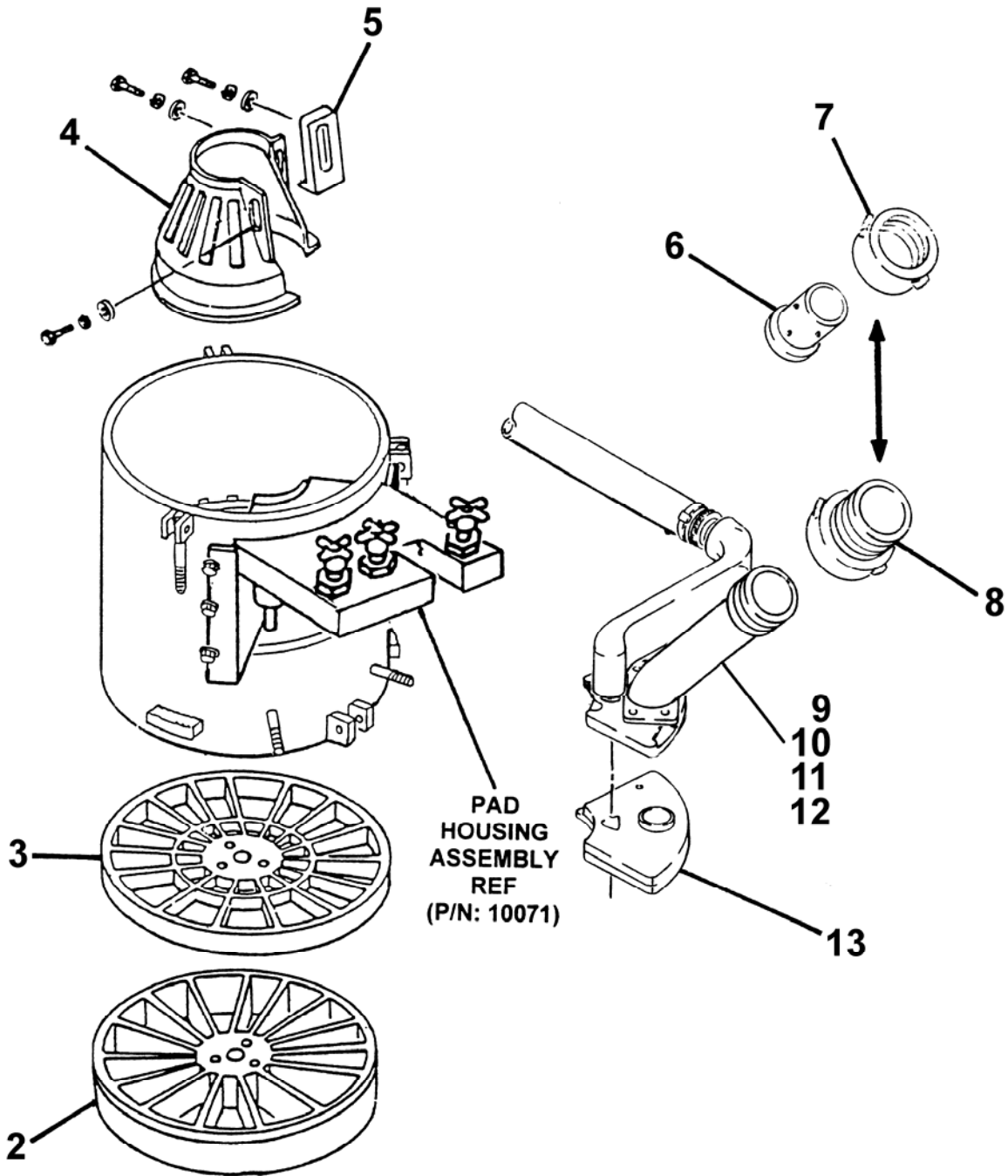

REVISION:



**15 POCKET LARGE AGGREGATE
DIVIDERLESS FEED WHEEL
AND PAD BACKUP ASSEMBLY**

**LOVA
PARTS
GROUP 70
FIGURE 06
PAGE 02**

ITEM NO.	REED'S PARTS NO.	DESCRIPTION	QTY
		1 2 3 4 5	
-1	70-06	Installation, 15 Pocket Large Aggregate Dividerless Feed Wheel and Pad Backup (See Group 70, Figure 01 for NHA)	Ref
2	10804	• Feed Bowl, 15 Pocket Dividerless Large Aggregate	1
3	10802	• Plate, 15 Pocket Large Aggregate Wear	1
4	10922	• Cone, Rock	1
5	10014	• Shear, Narrow Rock	1
6	11021	• End, Coarse 2 Inch Female Hose (Optional Item)	1
7	11033	• Nut, Coarse 2 Inch Coupling (Optional Item)	1
8	12087	• Adapter, 2 Inch to 2-1/2 Inch Goose Neck (Optional Item)	1
9	10665	• Assembly, 2 Inch Solid Large Aggregate Pad Backup (Optional Item) (See Group 40, Figure 10 for DET)	1
10	10666	• Assembly, 2 Inch Liner Type Large Aggregate Pad Backup (Optional Item) (See Group 70, Figure 14 for DET)	1
11	10667	• Assembly, 1-1/2 Inch Solid Large Aggregate Pad Backup (Optional Item) (See Group 70, Figure 15 for DET)	1
12	10669	• Assembly, 1-1/2 Inch Liner Type Large Aggregate Pad Backup (Optional Item) (See Group 70, Figure 17 for DET)	1
13	10336	• Wearpad, Rubber	1

DASH (-) ITEM NOT ILLUSTRATED

REVISION:



20 POCKET FEED WHEEL AND PAD BACKUP INSTALLATION

LOVA
PARTS
GROUP 70
FIGURE 07
PAGE 01

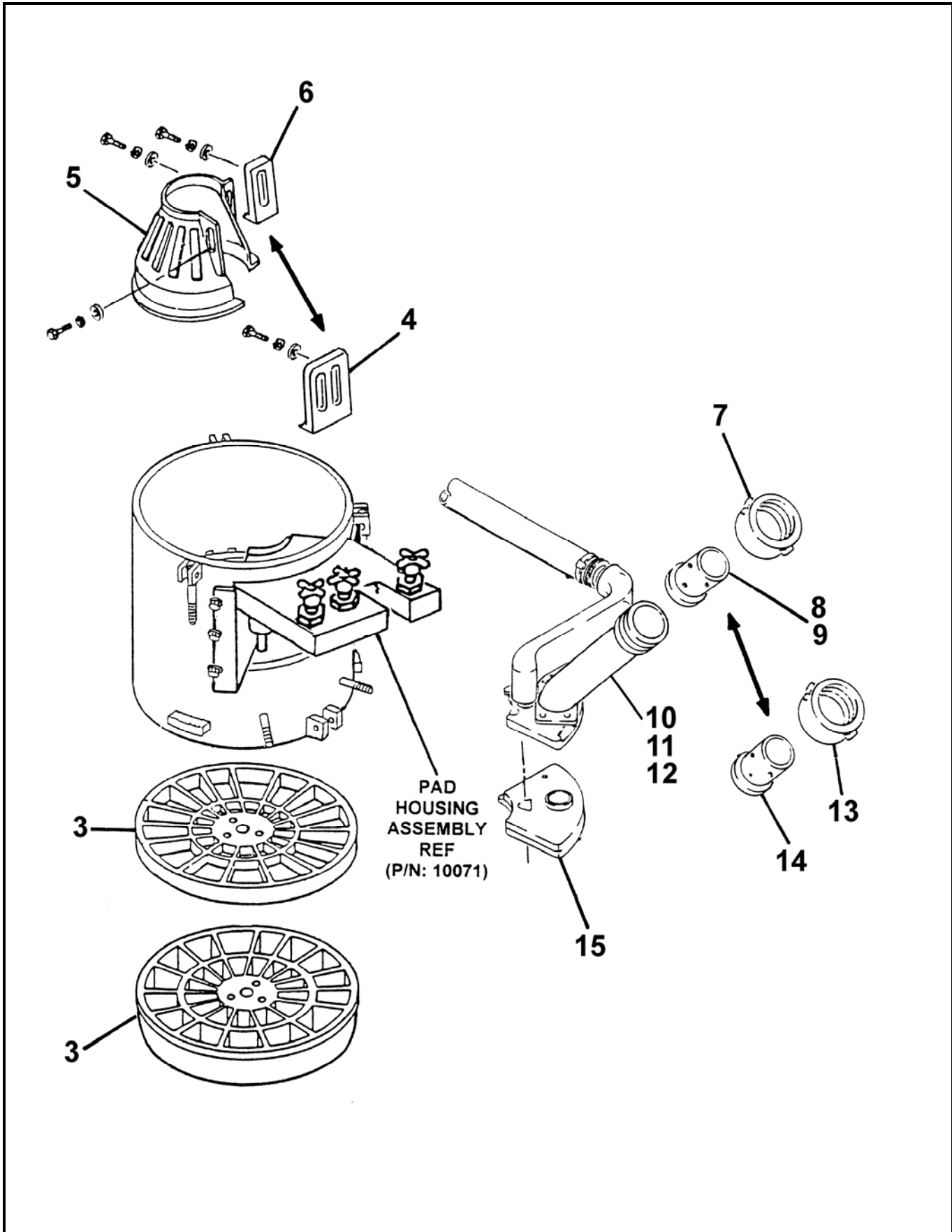

REVISION:



20 POCKET FEED WHEEL
AND PAD BACKUP INSTALLATION

LOVA
PARTS
GROUP 70
FIGURE 07
PAGE 02

ITEM NO.	REED'S PARTS NO.	DESCRIPTION	QTY
		1 2 3 4 5	
-1	70-07	Installation, 20 Pocket Feed Wheel and Pad Backup (See Group 70, Figure 01 for NHA)	Ref
2	10806	• Feed Bowl, 20 Pocket	1
3	10805	• Plate, 20 Pocket Wear	1
4	10013	• Shear, Wide Rock (Optional Item)	1
5	10936	• Weldment, Refractory Cone (Optional Item)	1
6	10014	• Shear, Narrow Rock (Optional Item)	1
7	11037	• Nut, Coarse 1-1/2 Inch Coupling (Optional Item)	1
8	11018	• End, Coarse 1-1/2 Inch Female Hose (Optional Item)	1
9	11019	• End, Coarse 1-1/2 Inch Female Hose (Optional Item)	1
10	10668	• Assembly, 1-1/2 Inch Liner Type standard Pad Backup (Optional Item) (See Group 70, Figure 16 for DET)	1
11	10661	• Assembly, 1-1/4 Inch Solid Pad Backup (Optional Item) (See Group 70, Figure 10 for DET)	1
12	10662	• Assembly, 1-1/2 Inch Solid Pad Backup (Optional Item) (See Group 70, Figure 11 for DET)	1
13	11036	• Nut, Coarse 1 and 1-1/4 Inch Coupling (Optional Item - used on P/N: 10661 and 10662)	1
14	11023	• End, Coarse 1-1/4 Inch Female Hose (Optional Item - used on P/N: 10661 and 10662)	1
15	10338	• Wearpad, Rubber	1

DASH (-) ITEM NOT ILLUSTRATED

REVISION:

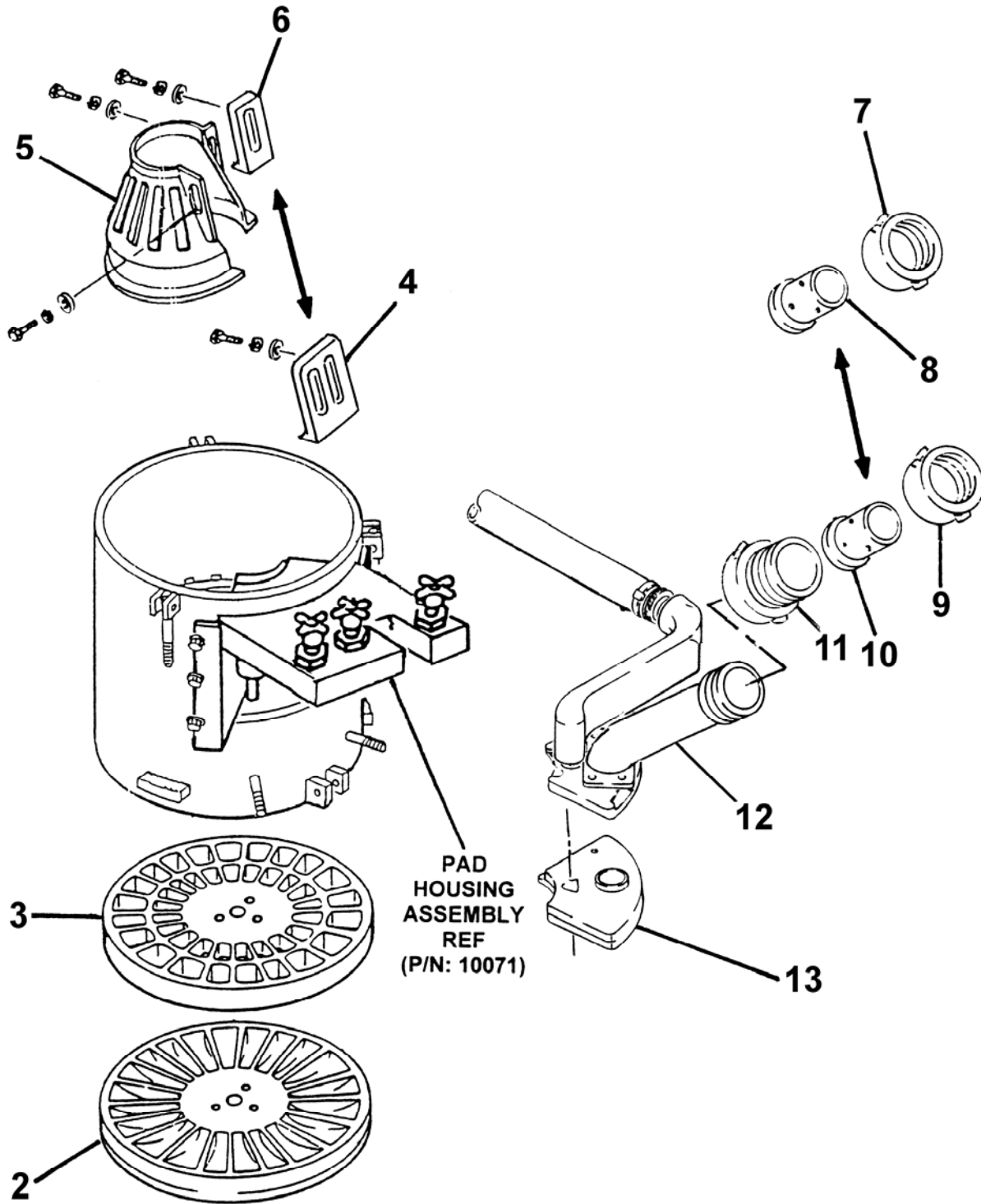



21 POCKET FEED WHEEL
AND PAD BACKUP INSTALLATION

LOVA
PARTS
GROUP 40
FIGURE 08
PAGE 02

ITEM NO.	REED'S PARTS NO.	DESCRIPTION	QTY
		1 2 3 4 5	
-1	70-08	Installation, 21 Pocket Feed Wheel and Pad Backup (See Group 70, Figure 01 for NHA)	Ref
2	10808	• Feed Bowl, 21 Pocket	1
3	10807	• Plate, 21 Pocket Wear	1
4	10013	• Shear, Wide Rock (Optional Item)	1
5	10936	• Weldment, Refractory Cone (Optional Item)	1
6	10014	• Shear, Narrow Rock (Optional Item)	1
7	11036	• Nut, Coarse 1-1/4 Inch Coupling (Optional Item)	1
8	11023	• End, Coarse 1-1/4 Inch Female Hose (Optional Item)	1
9	11030	• Nut, Fine 1-1/4 Inch Coupling (Optional Item)	1
10	11016	• End, Fine 1 Inch Female Hose (Optional Item)	1
11	12085	• Adapter to Reducer to 1 Inch or 3/4 Inch Hose	1
12	10661	• Assembly, 1-1/4 Inch Solid Pad Backup (Optional Item) (See Group 70, Figure 10 for DET)	1
13	10339	• Wearpad, Rubber	1

DASH (-) ITEM NOT ILLUSTRATED

REVISION:

30 POCKET FEED WHEEL AND PAD BACKUP INSTALLATION

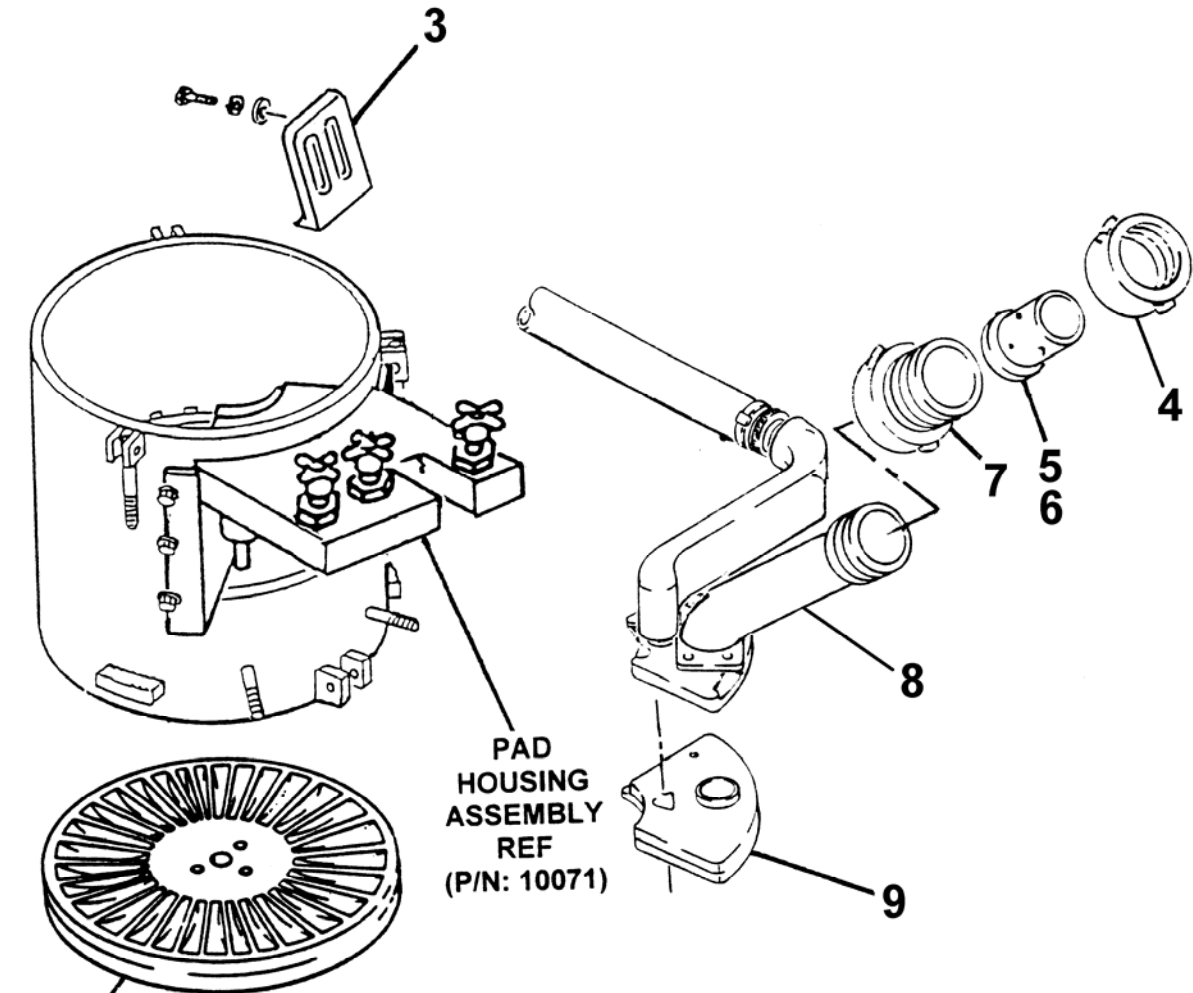

PAD
HOUSING
ASSEMBLY
REF
(P/N: 10071)

NOTE: 30 POCKET FEED BOWL
NO WEAR PLATE REQUIRED

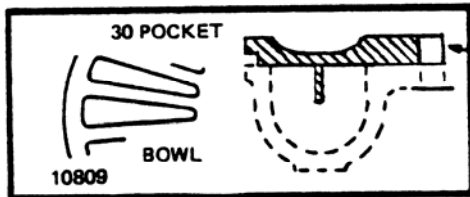

Shallow 30 Pocket Feed Bowl.
Mounts directly on top of any
existing Feed Bowl.



**30 POCKET FEED WHEEL
AND PAD BACKUP INSTALLATION**

**LOVA
PARTS
GROUP 70
FIGURE 09
PAGE 02**

ITEM NO.	REED'S PARTS NO.	DESCRIPTION	QTY
		1 2 3 4 5	
-1	70-09	Installation, 30 Pocket Feed Wheel and Pad Backup (See Group 70, Figure 01 for NHA)	Ref
2	10809	• Feed Bowl, 30 Pocket	1
3	10013	• Shear, Wide Rock	1
4	11030	• Nut, Fine 1-1/4 Inch Coupling	1
5	11016	• End, Fine 1 Inch Female Hose (Optional Item)	1
6	11015	• End, Fine 3/4 Inch Female Hose (Optional Item)	1
7	12085	• Adapter 1 1/4 to Adapter 1 Inch or 3/4 Inch Hose	1
8	10661	• Assembly, 1-1/4 Inch Solid Pad Backup (Optional Item) (See Group 70, Figure 10 for DET)	1
9	10339	• Wearpad, Rubber	1

DASH (-) ITEM NOT ILLUSTRATED

REVISION:



1-1/4 INCH SOLID
PAD BACKUP ASSEMBLY

LOVA
PARTS
GROUP 70
FIGURE 10
PAGE 01

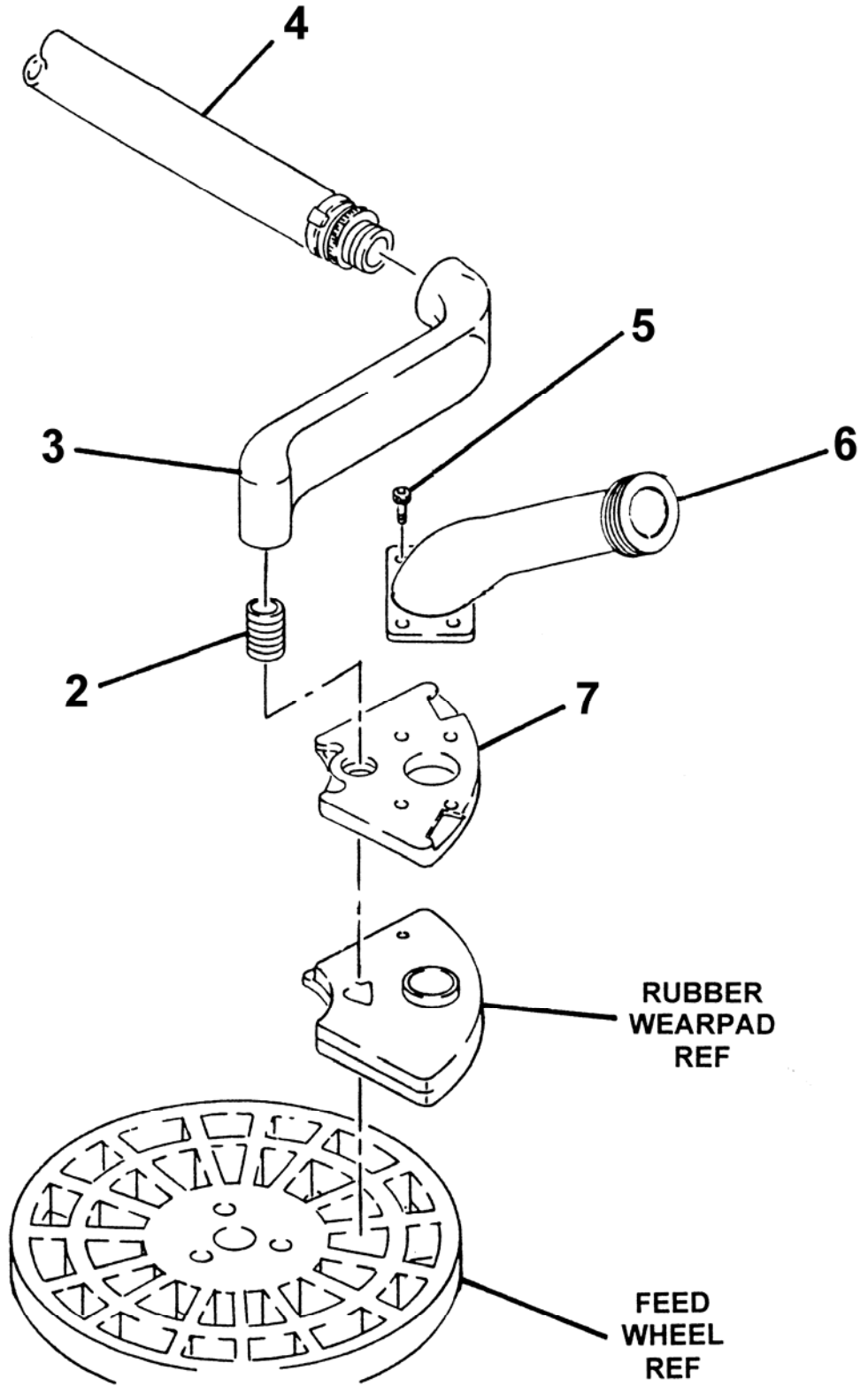

REVISION:



1-1/4 INCH SOLID
PAD BACKUP ASSEMBLY

LOVA
PARTS
GROUP 70
FIGURE 10
PAGE 02

ITEM NO.	REED'S PARTS NO.	DESCRIPTION	QTY
		1 2 3 4 5	
-1	10661	Assembly, 1-1/4 Inch Solid Pad Backup (See Group 70, Figure 07 and 08 for NHA)	Ref
2	10232	• Nipple	1
3	10219	• Inlet, Air	1
4	10260	• Assembly, Crossover Hose	1
5	80270	• Screw, Phillister Head Long	4
6	10043	• Weldment, 1-1/4 Inch Solid Goose Neck	1
7	60012	• Plate, Pad Backup	1

DASH (-) ITEM NOT ILLUSTRATED

REVISION:



1-1/2 INCH SOLID STANDARD
PAD BACKUP ASSEMBLY

LOVA
PARTS
GROUP 70
FIGURE 11
PAGE 01

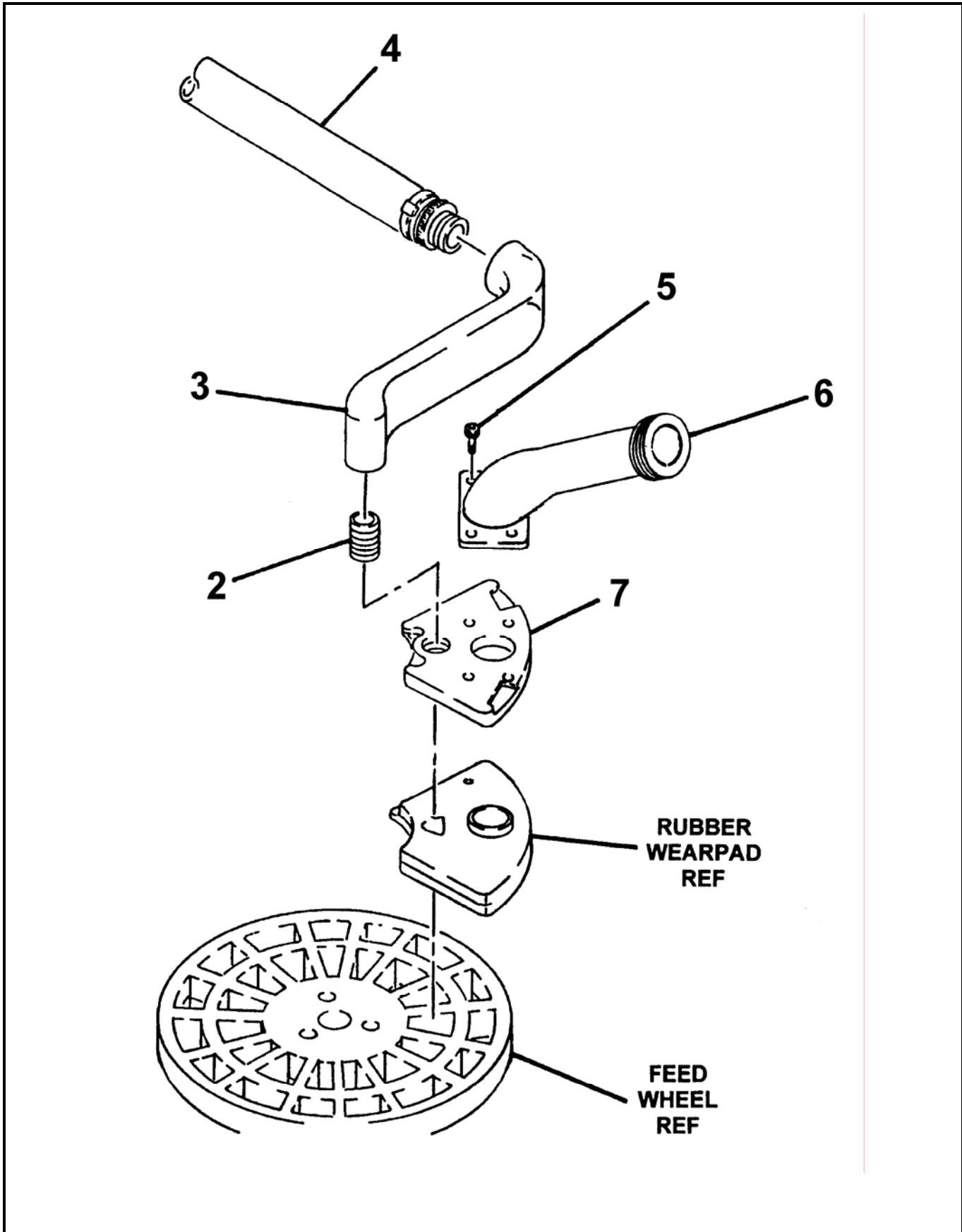

REVISION:



1-1/2 INCH SOLID STANDARD
PAD BACKUP ASSEMBLY

LOVA
PARTS
GROUP 70
FIGURE 11
PAGE 02

ITEM NO.	REED'S PARTS NO.	DESCRIPTION	QTY
		1 2 3 4 5	
-1	10662	Assembly, 1-1/2 Inch Solid Standard Pad Backup (See Group 70, Figure 07 for NHA)	Ref
2	10232	• Nipple	1
3	10219	• Inlet, Air	1
4	10260	• Assembly, Crossover Hose	1
5	80270	• Screw, Phillister Head Long	4
6	10044	• Weldment, 1-1/2 Inch Solid Goose Neck	1
7	60012	• Plate, Pad Backup	1

DASH (-) ITEM NOT ILLUSTRATED

REVISION:



2 INCH LINER TYPE STANDARD
PAD BACKUP ASSEMBLY

LOVA
PARTS
GROUP 70
FIGURE 12
PAGE 01

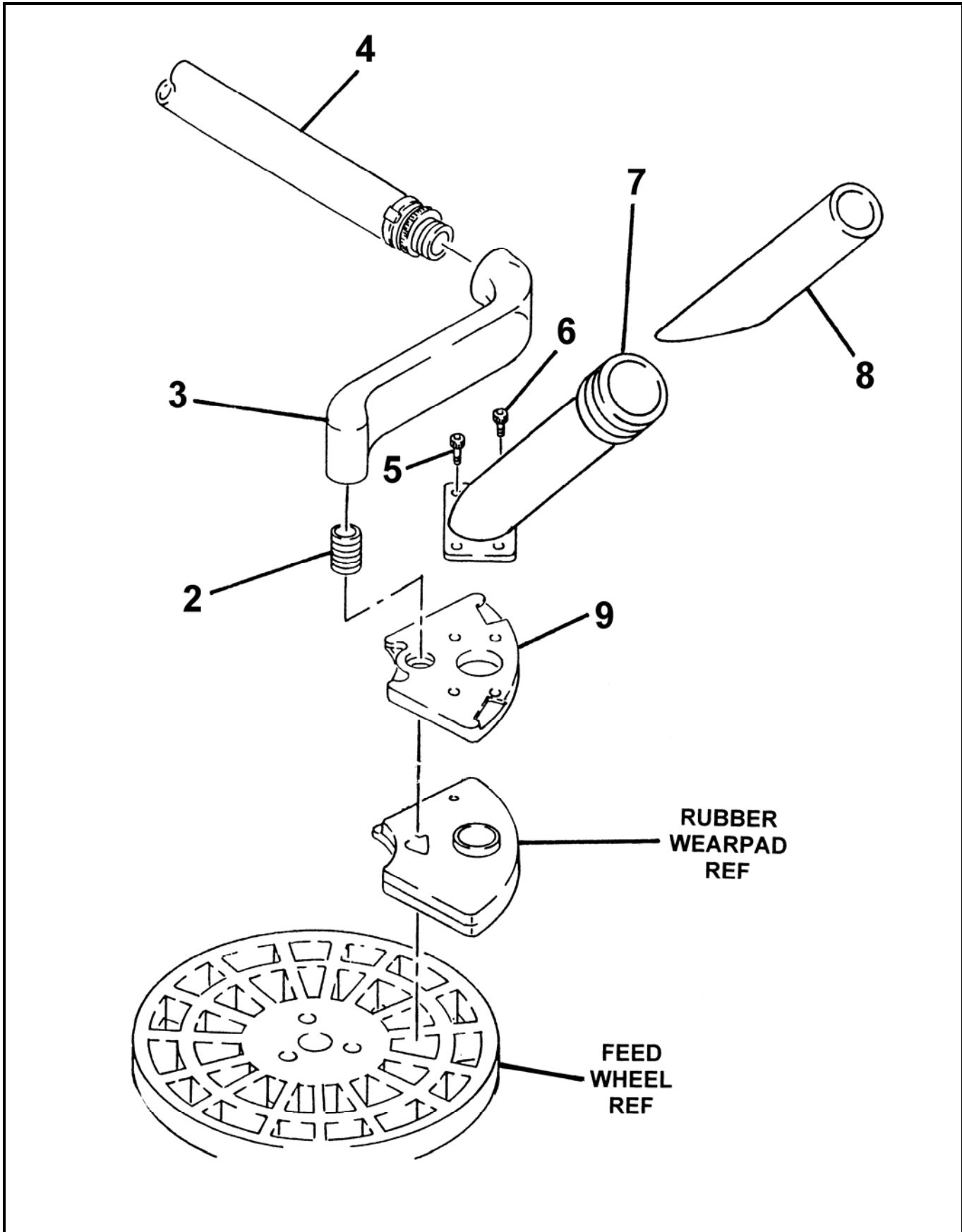

REVISION:



2 INCH LINER TYPE STANDARD
PAD BACKUP ASSEMBLY

LOVA
PARTS
GROUP 70
FIGURE 12
PAGE 02

ITEM NO.	REED'S PARTS NO.	DESCRIPTION	QTY
		1 2 3 4 5	
-1	10663	Assembly, 2 Inch Liner Type Standard Pad Backup (See Group 70, Figure 04 for NHA)	Ref
2	10232	• Nipple	1
3	10219	• Inlet, Air	1
4	10260	• Assembly, Crossover Hose	1
5	80270	• Screw, Phillister Head Long	2
6	80268	• Screw, Phillister Head Short	2
7	10046	• Weldment, 2 Inch Liner Type Goose Neck	1
8	10958	• Liner, 2 Inch Goose Neck	1
9	10954	• Plate, 2 Inch Pad Backup	1

DASH (-) ITEM NOT ILLUSTRATED

REVISION:



2 INCH SOLID STANDARE
PAD BACKUP ASSEMBLY

LOVA
PARTS
GROUP 70
FIGURE 13
PAGE 01

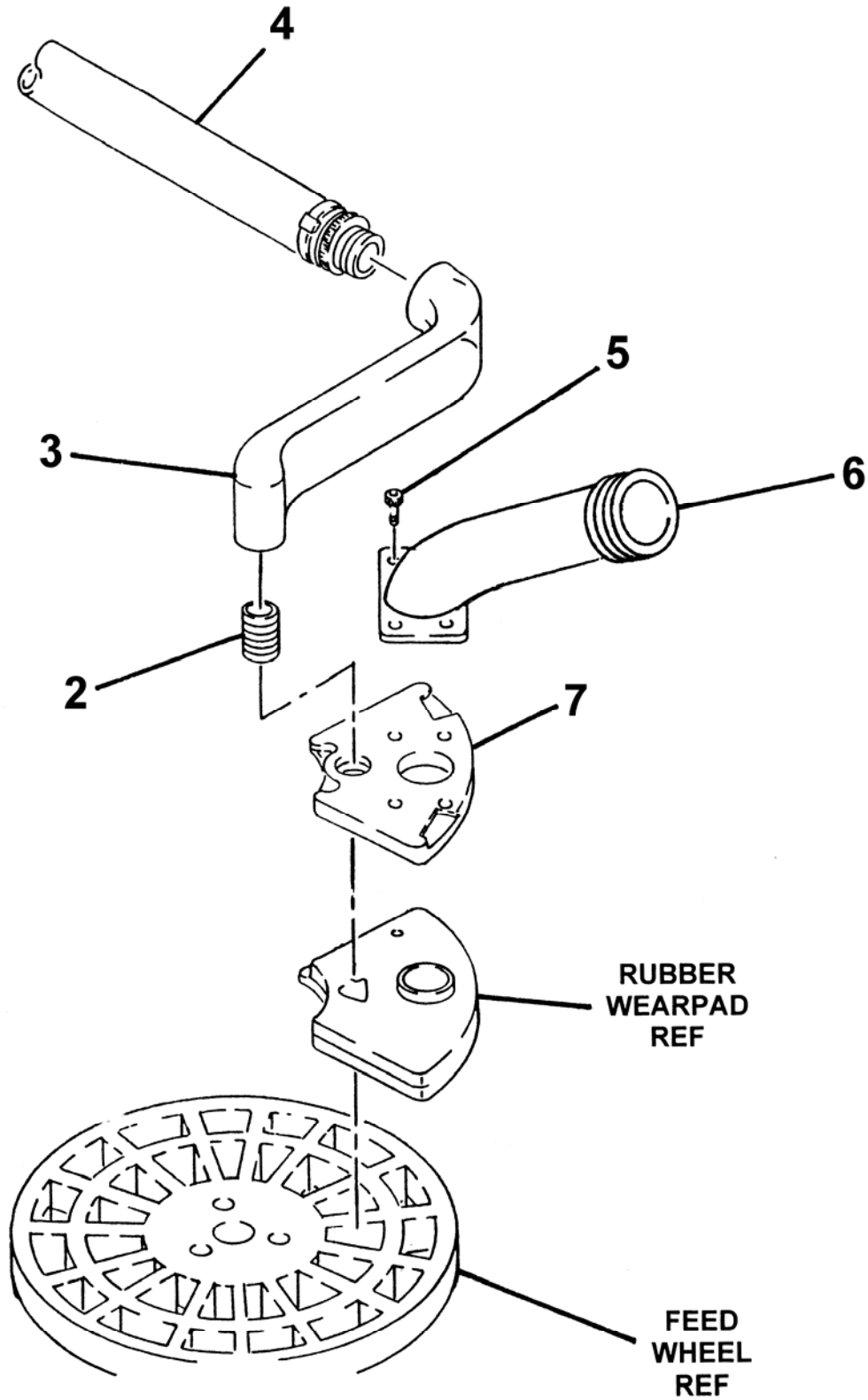

REVISION:



2 INCH SOLID STANDARD
PAD BACKUP ASSEMBLY

LOVA
PARTS
GROUP 70
FIGURE 13
PAGE 02

ITEM NO.	REED'S PARTS NO.	DESCRIPTION	QTY
		1 2 3 4 5	
-1	10664	Assembly, 2 Inch Solid Standard Pad Backup (See Group 70, Figure 04 for NHA)	Ref
2	10232	• Nipple	1
3	10219	• Inlet, Air	1
4	10260	• Assembly, Crossover Hose	1
5	80270	• Screw, Phillister Head Long	4
6	10045	• Weldment, 2 Inch Solid Goose Neck	1
7	60012	• Plate, Pad Backup	1

DASH (-) ITEM NOT ILLUSTRATED

REVISION:

2 INCH LINER TYPE LARGE AGGREGATE PAD BACKUP ASSEMBLY

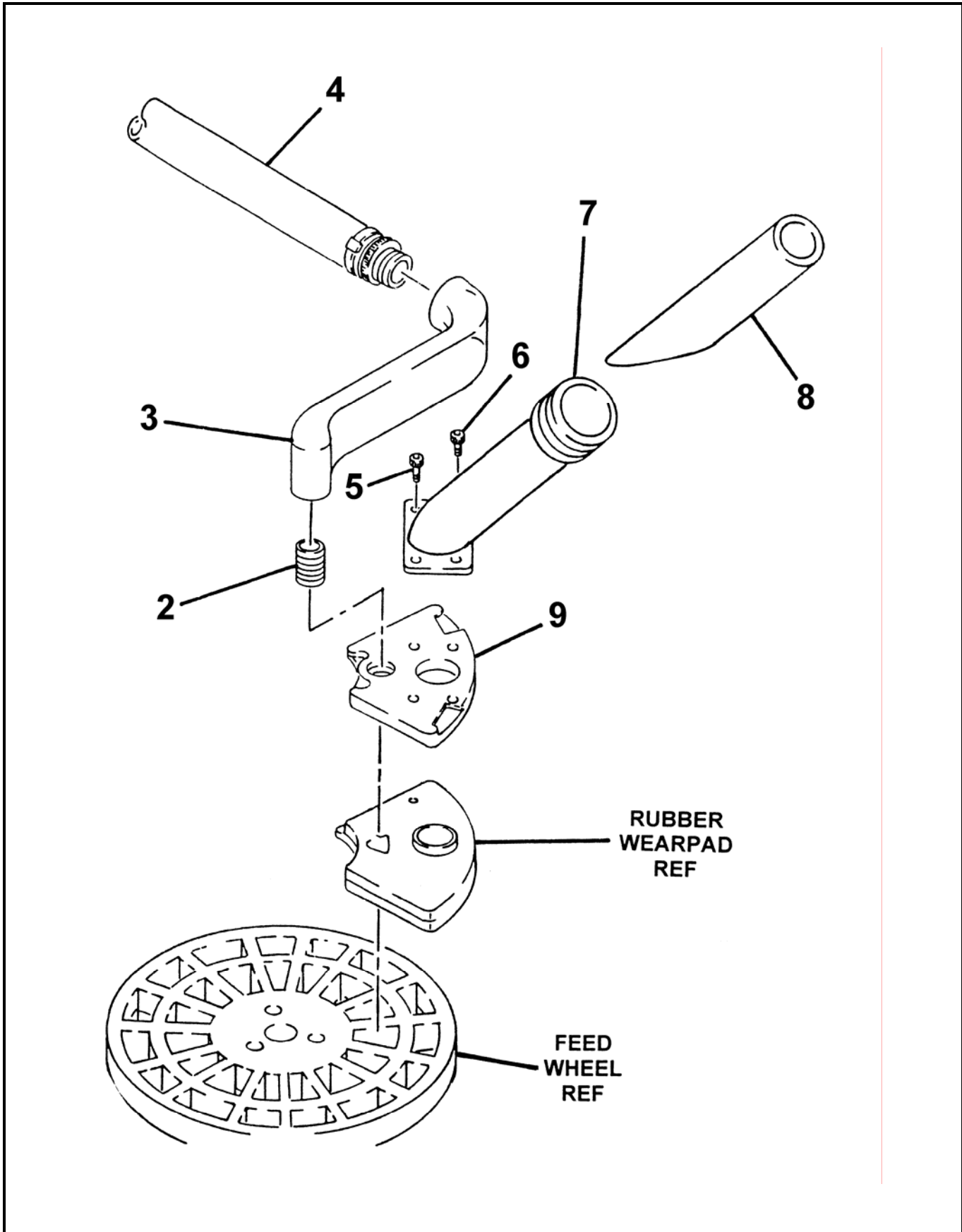



**2 INCH LINER TYPE LARGE AGGREGATE
PAD BACKUP ASSEMBLY**

**LOVA
PARTS
GROUP 70
FIGURE 14
PAGE 02**

ITEM NO.	REED'S PARTS NO.	DESCRIPTION	QTY
		1 2 3 4 5	
-1	10666	Assembly, 2 Inch Liner Type Large Aggregate Pad Backup (See Group 70, Figure 03, 05 and 06 for NHA)	Ref
2	10232	• Nipple	1
3	10219	• Inlet, Air	1
4	10260	• Assembly, Crossover Hose	1
5	80270	• Screw, Phillister Head Long	2
6	80268	• Screw, Phillister Head Short	2
7	10046	• Weldment, 2 Inch Liner Type Goose Neck	1
8	10958	• Liner, 2 Inch Goose Neck	1
9	10953	• Plate, 2 Inch Pad Backup	1

DASH (-) ITEM NOT ILLUSTRATED

REVISION:



1-1/2 INCH SOLID LARGE AGGREGATE
PAD BACKUP ASSEMBLY

LOVA
PARTS
GROUP 70
FIGURE 15
PAGE 01

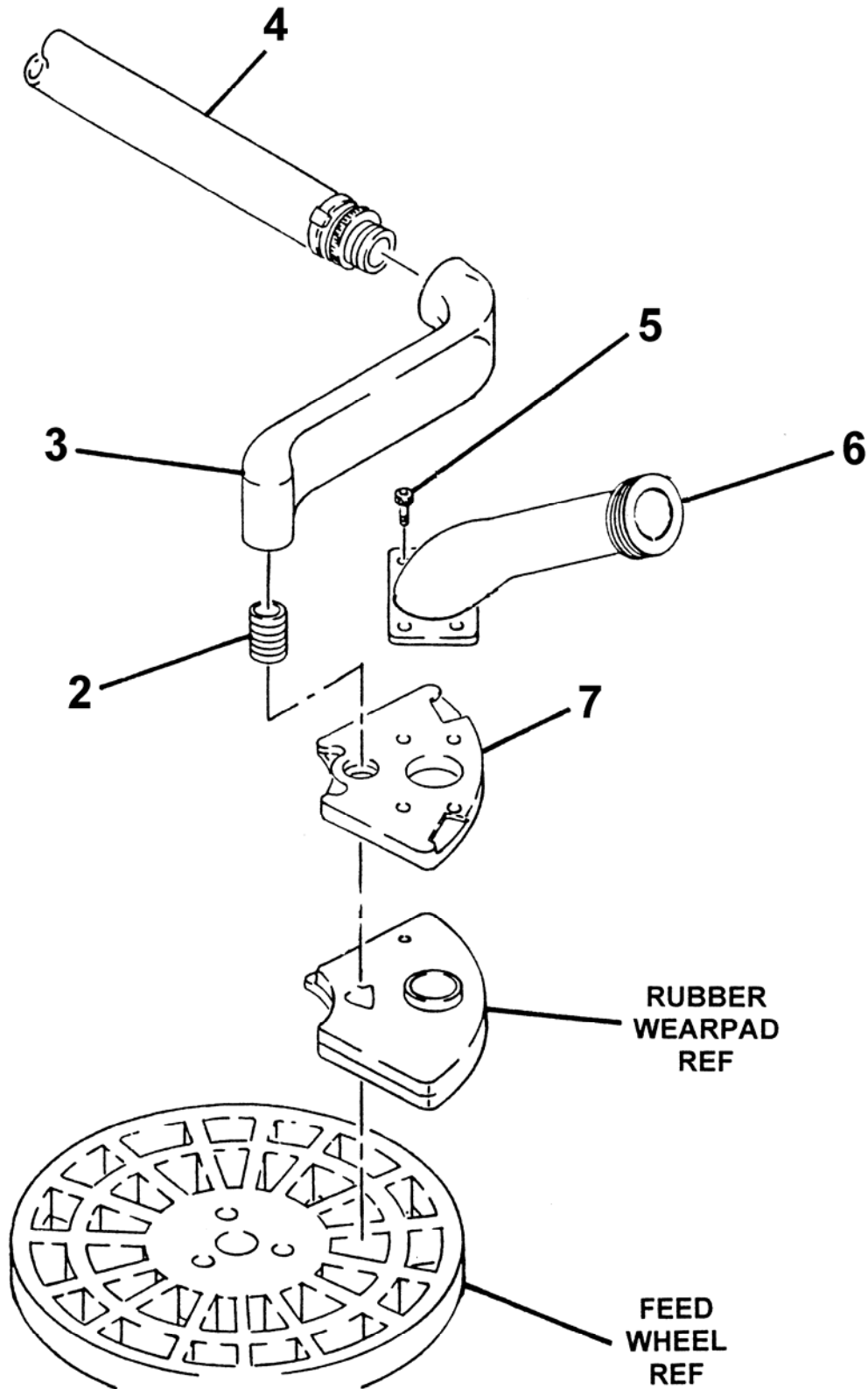

REVISION:



1-1/2 INCH SOLID LARGE AGGREGATE
PAD BACKUP ASSEMBLY

LOVA
PARTS
GROUP 70
FIGURE 15
PAGE 02

ITEM NO.	REED'S PARTS NO.	DESCRIPTION	QTY
		1 2 3 4 5	
-1	10667	Assembly, 2 Inch Solid Large Aggregate Pad Backup (See Group 70, Figure 05 and 06 for NHA)	Ref
2	10232	• Nipple	1
3	10219	• Inlet, Air	1
4	10260	• Assembly, Crossover Hose	1
5	80270	• Screw, Phillister Head Long	4
6	10044	• Weldment, 1-1/2 Inch Solid Goose Neck	1
7	60010	• Plate, Pad Backup	1

DASH (-) ITEM NOT ILLUSTRATED

REVISION:



1-1/2 INCH LINER TYPE STANDARD
PAD BACKUP ASSEMBLY

LOVA
PARTS
GROUP 70
FIGURE 16
PAGE 01

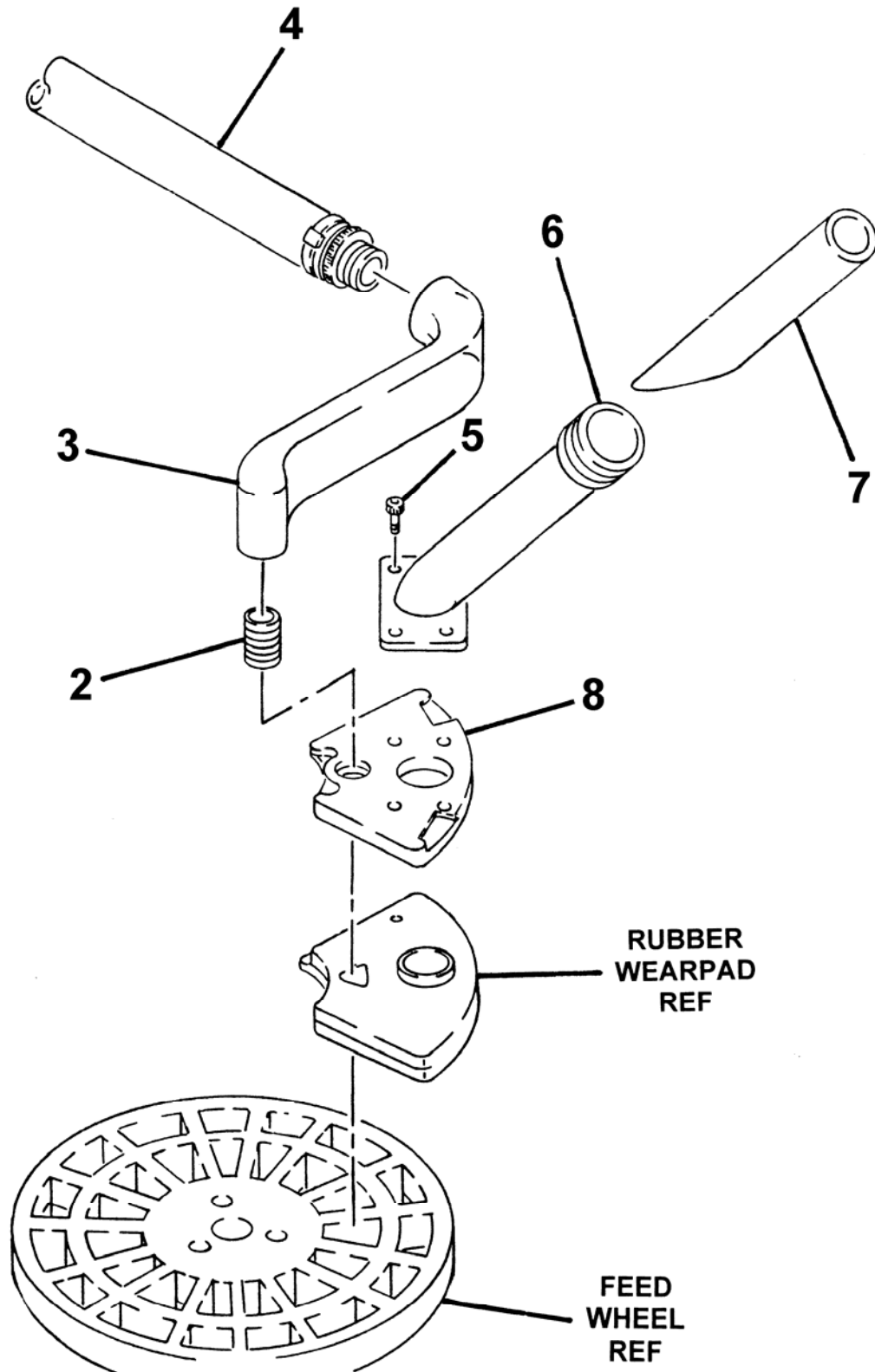

REVISION:



1-1/2 LINER TYPE STANDARD
PAD BACKUP ASSEMBLY

LOVA
PARTS
GROUP 70
FIGURE 16
PAGE 02

ITEM NO.	REED'S PARTS NO.	DESCRIPTION	QTY
		1 2 3 4 5	
-1	10668	Assembly, 1-1/2 Inch Liner Type Standard Pad Backup (See Group 70, Figure 04 and 07 for NHA)	Ref
2	10232	• Nipple	1
3	10219	• Inlet, Air	1
4	10260	• Assembly, Crossover Hose	1
5	80270	• Screw, Phillister Head Long	2
6	80268	• Screw, Phillister Head Short	2
7	10042	• Weldment, 1-1/2 Inch Liner Type Goose Neck	1
8	10959	• Liner, 1-1/2 Inch Goose Neck	1
9	60012	• Plate, Pad Backup	1

DASH (-) ITEM NOT ILLUSTRATED

REVISION:

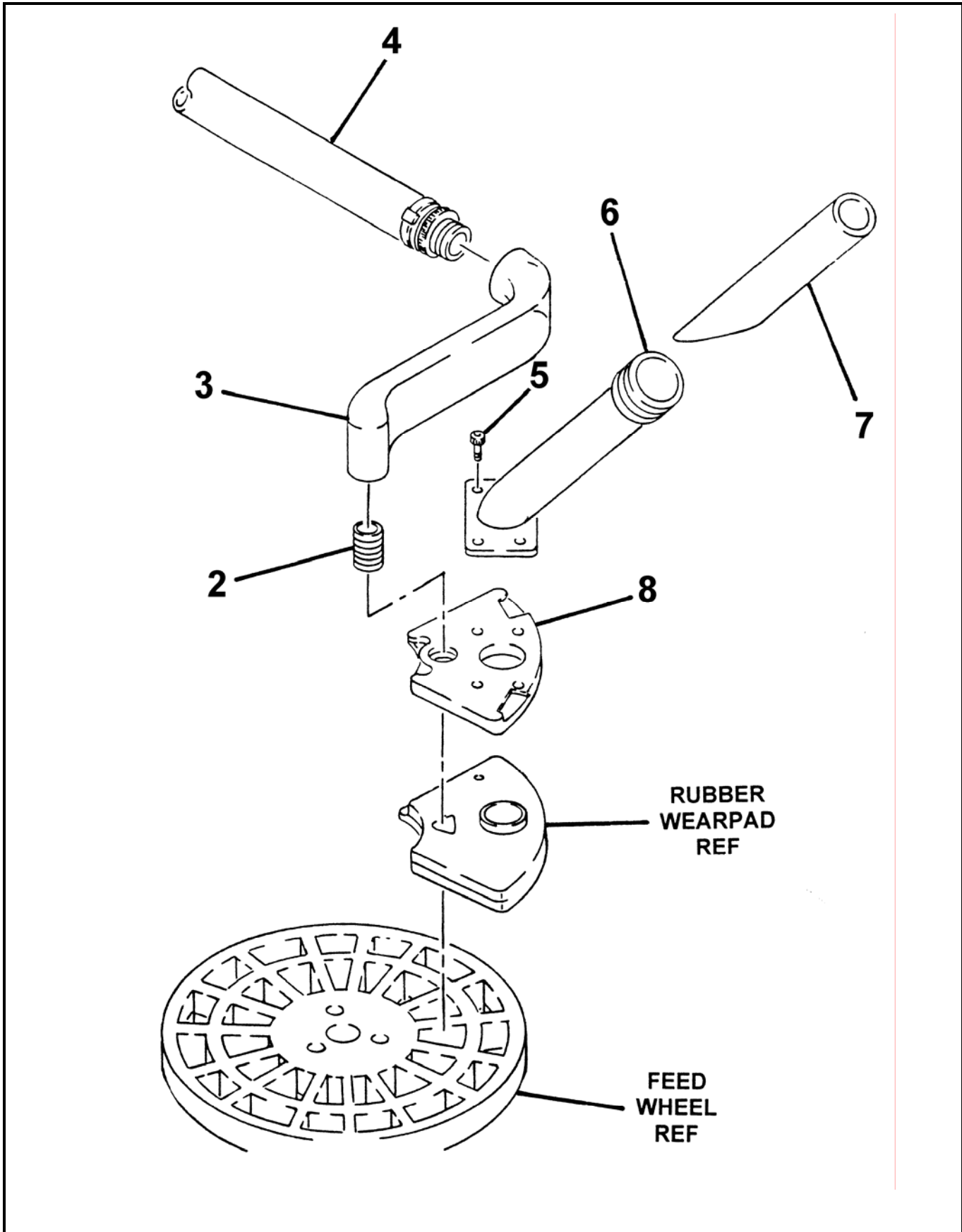



1-1/2 INCH LINER TYPE LARGE AGGREGATE
PAD BACKUP ASSEMBLY

LOVA
PARTS
GROUP 70
FIGURE 17
PAGE 02

ITEM NO.	REED'S PARTS NO.	DESCRIPTION	QTY
		1 2 3 4 5	
-1	10669	Assembly, 1-1/2 Inch Liner Type Large Aggregate Pad Backup (See Group 70, Figure 05 and 06 for NHA)	Ref
2	10232	• Nipple	1
3	10219	• Inlet, Air	1
4	10260	• Assembly, Crossover Hose	1
5	80270	• Screw, Phillister Head Long	2
6	80268	• Screw, Phillister Head Short	2
7	10042	• Weldment, 1-1/2 Inch Liner Type Goose Neck	1
8	10959	• Liner, 1-1/2 Inch Goose Neck	1
9	60010	• Plate, Pad Backup	1

DASH (-) ITEM NOT ILLUSTRATED

REVISION:



2 INCH LINER TYPE LARGE AGGREGATE
1-1/4 AIR INLET PAD BACKUP ASSEMBLY

LOVA
PARTS
GROUP 70
FIGURE 18
PAGE 01

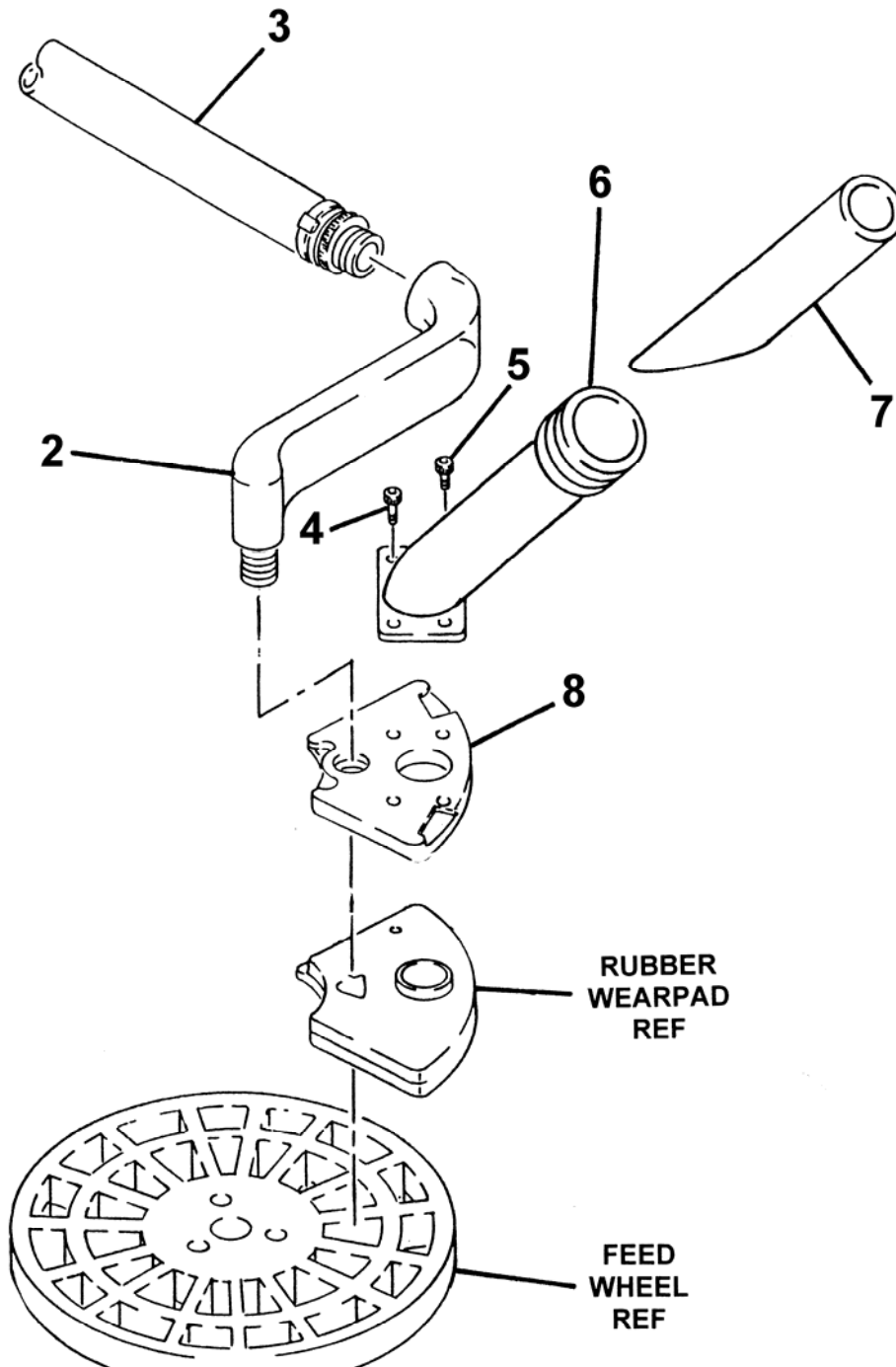

REVISION:



2 INCH LINER TYPE LARGE AGGREGATE
PAD BACKUP ASSEMBLY

LOVA
PARTS
GROUP 70
FIGURE 18
PAGE 02

ITEM NO.	REED'S PARTS NO.	DESCRIPTION	QTY
		1 2 3 4 5	
-1	10670	Assembly, 2 Inch Liner Type Large Aggregate, 1-1/4 Air Inlet Pad Backup (See Group 70, Figure 01 and for NHA)	Ref
2	10217	• Inlet, Air	1
3	10260	• Assembly, Crossover Hose	1
4	80270	• Screw, Phillister Head Long	2
5	80268	• Screw, Phillister Head Short	2
6	10046	• Weldment, 2 Inch Liner Type Goose Neck	1
7	10958	• Liner, 2 Inch Goose Neck	1
8	10955	• Plate, 2 Inch Pad Backup	1

DASH (-) ITEM NOT ILLUSTRATED

REVISION:



MODEL LOVA PNEUMATIC SPRAYING MACHINE
ILLUSTRATED PARTS MANUAL

LOVA
PARTS
GROUP 70
FIGURE 19
PAGE 01

THIS PAGE INTENTIONALLY LEFT BLANK.



GUNITE ACCESSORY CATALOG

TOOLS, SUPPLIES, AND PARTS

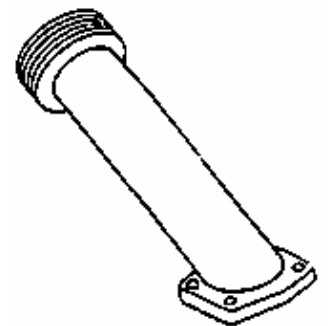
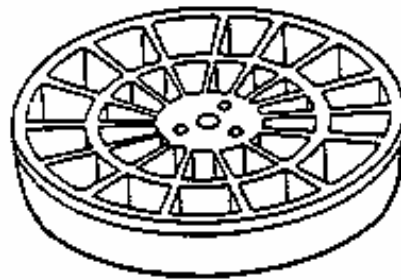
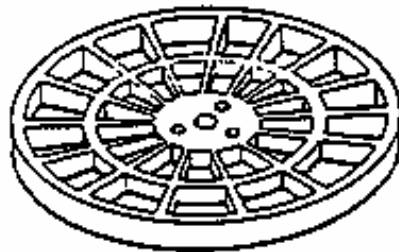



TABLE OF CONTENTS

TERMS AND CONDITIONS.....	2
LIMITED WARRANTY.....	3
GUNITE HOSE.....	4
COUPLING ASSEMBLIES AND ADAPTERS.....	5
NOZZLE ASSEMBLIES.....	7
GUNITE TOOLS AND SUPPLIES	
SPIROLET NOZZLE.....	8
AIR/WATER HOSE.....	8
SHOOTING WIRE.....	8
CUTTING RODS, FRESNOS, TROWELS, FLOATS.....	9
BOOSTER PUMPS.....	10
SAFETY DECALS.....	11
RECOMMENDED SPARE PARTS	
LOVA/LOHE.....	12
LOVA/LOHE – SERIES IV.....	14
SOVA/SOVE.....	16
209A/209E.....	17
215A/215E.....	18
LOVA 8 TO LOVA 16 CHANGEOVER.....	19



TERMS AND CONDITIONS

PRICES, DESIGNS AND TERMS AND CONDITIONS OF SALE ARE SUBJECT TO CHANGE WITHOUT NOTICE.

ALL MATERIAL IS CAREFULLY EXAMINED, COUNTED, AND PACKED BY EXPERIENCED EMPLOYEES. CLAIMS FOR CORRECTIONS MUST BE MADE WITHIN 10 DAYS OF RECEIPT OF GOOD. OUR RESPONSIBILITY CEASES WHEN GOODS ARE DELIVERED TO CARRIER IN GOOD CONDITION AND ITS RECEIPT OBTAINED. CARRIERS ARE RESPONSIBLE FOR GOODS LOST, DAMAGED, OR DELAYED IN TRANSIT. FOR YOUR OWN PROTECTION, HAVE TRANSPORTATION COMPANY'S AGENT VERIFY DAMAGES, SHORTAGES, OR DELAYS AND NOTE THEM ON FREIGHT BILL OVER HIS SIGNATURE.

- ALL WEIGHTS ARE APPROXIMATE SHIPPING WEIGHTS AND SUBJECT TO CHANGE WITHOUT NOTICE.
- PRICES ARE SUBJECT TO CHANGE WITHOUT NOTICE. IN ACCORDANCE WITH OUR ESTABLISHED POLICY OF CONSTANT IMPROVEMENT, WE RESERVE THE RIGHT TO AMEND OUR SPECIFICATIONS AT ANY TIME WITHOUT NOTICE.
- ALL PRICES ARE F.O.B. SHIPPING POINT WITH FREIGHT CHARGES COLLECT.
- GOODS MAY NOT BE RETURNED EXCEPT WITH PRIOR APPROVAL AND ISSUANCE OF RETURN GOODS AUTHORIZATION NUMBER FROM OUR FACTORY. A 15% RESTOCKING CHARGE WILL APPLY TO ALL GOODS RETURNED.

TO PLACE AN ORDER PLEASE CONTACT US AT:

13822 OAKS AVENUE
CHINO, CA 91710 U.S.A.

PHONE: 909-287-2106 OR 909-287-2112
TOLL FREE OUTSIDE CALIFORNIA: 888-779-**REED**

FAX: 909-287-2141

OR CONTACT YOUR LOCAL **REED** DEALER



SPARE PARTS LIMITED WARRANTY

REED warrants each of its replacement parts to be free of defects in material and workmanship under normal use and service for a period of sixty (60) days from date of delivery.

The warranty periods begins when the part is delivered to the initial buyer. Said warranty is void if the machine/parts is subject to misuse, neglect, accident or abuse.

REED'S obligation under this warranty is limited to correcting without charge, at its factory, any parts or parts thereof which shall be returned to its factory, transportation prepaid and upon **REED'S** examination proves to have been originally defective. Correction of such defects by repair or replacement shall constitute fulfillment of all obligations to the buyer. This warranty does not include labor or transportation charges unless specifically identified and authorized in writing by **REED**. Nor does the warranty apply to any part upon which repairs or unauthorized alterations have been made.

This warranty does not apply to normal maintenance service or to normal replacement of certain parts which are subject to normal wear (such as feed bowls, wear plates, wear pads, liners, delivery systems, filters, wear rings, piston cups, etc.). **REED** makes no warranty in respect to trade accessories or outside vendor components, such being subject to the warranties of their respective manufacturers.

THIS IS A LIMITED WARRANTY AND IS IN LIEU OF ANY OTHER WARRANTIES, EXPRESSED OR IMPLIED, INCLUDING ANY WARRANTY OF MERCHANTABILITY OR FITNESS FOR A PARTICULAR PURPOSE. In no event shall **REED** be liable for incidental, general or consequential damages, loss or any expense directly or indirectly related and resulting from use or lack of use caused by delay in delivery, parts failure, or any other causes associated with the use of the part. No person, firm or corporation is authorized to assume for **REED** any other liability in connection with the sale of **REED** products.

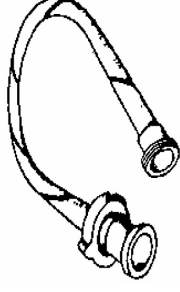

GUNITE MATERIAL HOSE

COUPLED "COARSE"	COUPLED "FINE"	NOT COUPLED	DESCRIPTION	I.D.(IN.)	O.D.(IN.)	WGT./FT Lbs.
N/A	40526	40525	STATIC CONDUCTING WITH STURDY BLACK JACKET	1	1.81	0.90
40532	40531	40530	STATIC CONDUCTING WITH STURDY BLACK JACKET	1.25	2.06	1.22
40537	40502	40535	STATIC CONDUCTING WITH STURDY BLACK JACKET	1.5	2.44	1.54
40452	N/A	40451	NON-STATIC CONDUCTING WITH TAN GUM RUBBER	2	2.94	1.91
40448	N/A	40449	STATIC CONDUCTING WITH TAN JACKET	2	2.94	1.91
40538	N/A	40489	STATIC CONDUCTING WITH TAN JACKET	2.5	3.47	2.38

UPDATED 4/6/2006



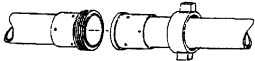

COUPLINGS AND ADAPTERS

CATEGORY	PART#	DESCRIPTION
COUPLING ASSEMBLIES 	11007	2½" COUPLING ASSEMBLY – COARSE
	11006	2" COUPLING ASSEMBLY – COARSE
	11004	1½" COUPLING ASSEMBLY – FINE (2 3/8" O.D.)
	11003	1½" COUPLING ASSEMBLY – FINE (2½" O.D.)
	11012	1½" COUPLING ASSEMBLY – COARSE (2 3/8" O.D.)
	11011	1½" COUPLING ASSEMBLY – COARSE (2½" O.D.)
	11002	1¼" COUPLING ASSEMBLY – FINE
	11010	1¼" COUPLING ASSEMBLY – COARSE
	11001	1" COUPLING ASSEMBLY – FINE
	11000	¾" COUPLING ASSEMBLY - FINE

CATEGORY	PART#	DESCRIPTION
HOSE ENDS 	11047	2½" MALE HOSE END – COARSE
	11046	2" MALE HOSE END – COARSE
	11043	1½" MALE HOSE END – FINE (2½" O.D.)
	11044	1½" MALE HOSE END – FINE (2 3/8" O.D.)
	11049	1½" MALE HOSE END – COARSE (2½" O.D.)
	11050	1½" MALE HOSE END – COARSE (2 3/8" O.D.)
	11042	1¼" MALE HOSE END – FINE
	11048	1¼" MALE HOSE END – COARSE
	11041	1" MALE HOSE END – FINE
	11040	¾" MALE HOSE END - FINE
	11022	2½" FEMALE HOSE END
	11021	2" FEMALE HOSE END





COUPLINGS AND ADAPTERS

CATEGORY	PART#	DESCRIPTION
HOSE ENDS (CONT.) 	11018	1½" FEMALE HOSE END
	11019	1½" FEMALE HOSE END
	11023	1¼" FEMALE HOSE END – COARSE
	11017	1¼" FEMALE HOSE END – FINE
	11016	1" FEMALE HOSE END
	11015	¾" FEMALE HOSE END
CATEGORY	PART#	DESCRIPTION
COUPLING NUTS (NOT SHOWN)	11034	2½" COUPLING NUT – COARSE
	11033	2" COUPLING NUT – COARSE
	11031	1½" COUPLING NUT – FINE
	11037	1½" COUPLING NUT – COARSE
	11030	1¼" COUPLING NUT – FINE
	11036	1½" COUPLING NUT – COARSE
CATEGORY	PART#	DESCRIPTION
GOOSENECK ADAPTERS 	12085	1¼" COARSE TO 1¼" FINE (USED TO REDUCE DOWN TO 1" OR ¾" HOSE)
	12087	2" TO 2½" (USE TO INCREASE TO 2½" HOSE)
	12088	2" TO 1½" (USE TO REDUCE DOWN TO 1½")
	40078	1¼" TO 1½" (USE TO INCREASE TO 1½")

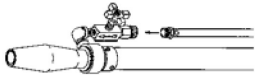
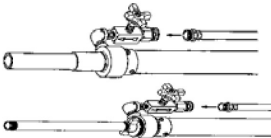

NOZZLE ASSEMBLIES AND ACCESSORIES

CATEGORY	PART#	DESCRIPTION
NOZZLE ASSEMBLIES 	12006	2½" NOZZLE ASSEMBLY – STANDARD – COARSE
	12005	2" NOZZLE ASSEMBLY – STANDARD – COARSE
	12010	1½" NOZZLE ASSEMBLY – STANDARD – COARSE
	12009	1¼" NOZZLE ASSEMBLY – STANDARD - FINE
	12009	1¼" NOZZLE ASSEMBLY – STANDARD - COARSE
	11980	2" HYDRO NOZZLE ASSEMBLY – MINE VERSION – (10 FOOT), COARSE
	40539	2" HYDRO NOZZLE ASSEMBLY – COARSE
	12092	2" HYDRO NOZZLE ASSEMBLY(DBL WATER RING)
	12036	1½" HYDRO NOZZLE ASSEMBLY - COARSE
	11981 12092	1¼" HYDRO NOZZLE ASSEMBLY - COARSE
	12001	1" NOZZLE ASSEMBLY – FINE
	12000	¾" NOZZLE ASSEMBLY-FINE
	11801	1" LANCE NOZZLE ASSEMBLY – FINE
	12022	1½" DOUBLE BUBBLE NOZZLE ASSEMBLY – COARSE
	12021	1¼" DOUBLE BUBBLE NOZZLE ASSEMBLY – COARSE
	12078	1½" DOUBLE BUBBLE HYDRO NOZZLE ASSEMBLY – COARSE

UPDATED 10/09/2008

NOT SUPPLIED BY REED

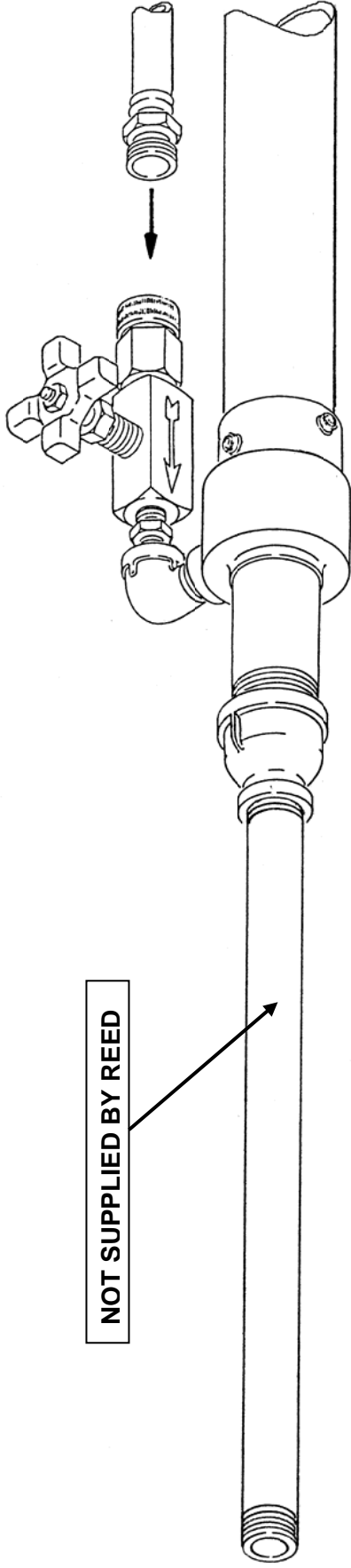

GENERAL NOTES:

ON ITEM #7-PN 12041 LINER IS TO BE TRIMMED SHORT TO FIT INSIDE THE BELL REDUCER.

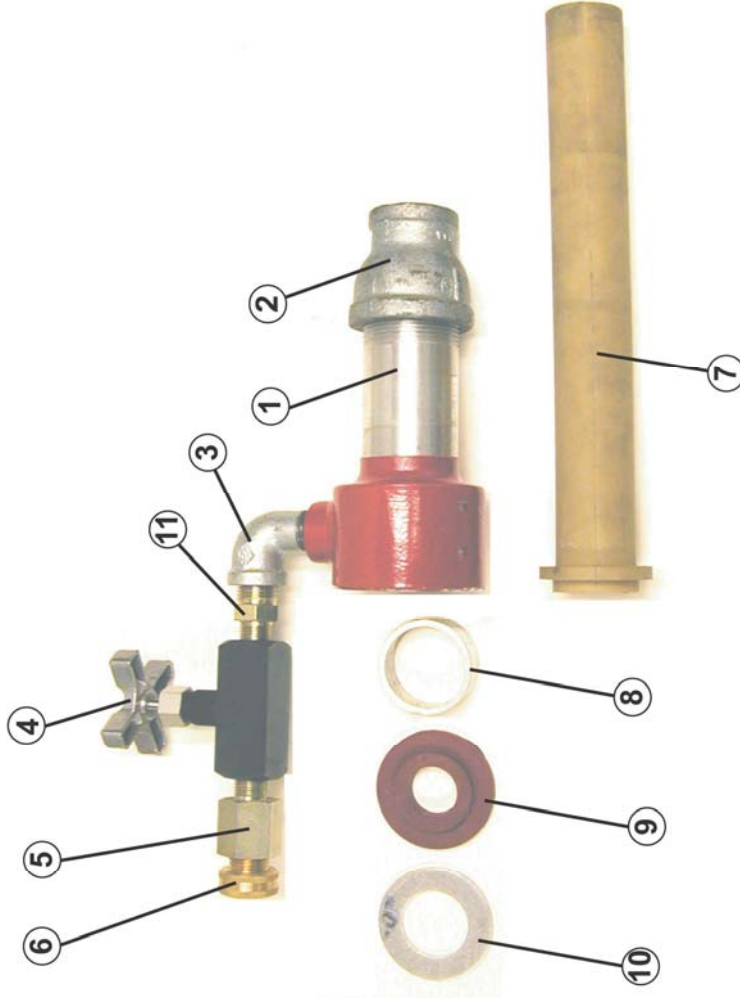

BILL OF MATERIALS

- # 1-PN 11813 BODY-NOZZLE, LANCE (QTY-1)
- # 2-PN 11810 BELL REDUCER 1 1/2" TO 1" (QTY-1)
- # 3-PN 10204 STREET ELBOW 90 -1/2" (QTY-1)
- # 4-PN 11029 VALVE NEEDLE-3/8" (QTY-1)
- # 5-PN 74675 REDUCER-1/2" TO 3/8" (QTY-1)
- # 6-PN 12061 ADAPTER-1/2" TO 3/4" (QTY-1)
- # 7-PN 12041 LINER-1" NOZZLE (QTY-1)
- # 8-PN 12064 WATER RING-1" (QTY-1)
- # 9-PN 12070 WASHER-BACKUP "FINE" (QTY-1)
- #10-PN 12080 WASHER-RETAINER 1 1/4" (QTY-1)
- #11-PN NPN MP-MP-8-6 STR FITTING (QTY-1)

REED CONCRETE PLACING EQUIPMENT
CHINO, CA 91710

TITLE: NOZZLE-LANCE ASSY-FINE
DRAWN BY: EYBARRA 8/25/03

PART NUMBER
11801
SHT 1 OF 1

REV



1/4x3/4 SHT MTL SCR-(20)

19

15

16

17

18

14

13

5

12

6

7

8

9

10

11

1

4

2

3

NOTE-B

- #1- PN 12004 NOZZLE TIP-2 "
- #2- PN 11033 NUT-COUPLING CRSE 2"
- #3- PN 40449 HOSE-2" GUNCRETE
- #4- PN 11021 END-HOSE-CRSE 2"
- #5- PN 11046 END-HOSE MALE-CRSE 2"
- #6- PN 11986 HOSE-GORILLA 1 3/16 X 3/4
- #7- PN 11989 HOSE BARB-3/4 MINE TYPE
- #8- PN 11987 NUT-SPUD 1" MINING

- #9- PN 12063 HANDLE-HYDRO NOZ
- #10- PN 74675 REDUCER-1/2 X 3/8
- #11- PN 11029 VALVE NEEDLE 3/8
- #12- PN 74890 ADAPTOR-1/2 NTPM X 3/8 NPTM
- #13- PN 10225 REDUCER-1 1/2
- #14- PN 12056 BODY-NOZZLE 2" CRSE
- #15- PN 12066 RING-2" WATER
- #16- PN 12074 WASHER-BACKUP 2" CRSE

- #17- PN 12083 WASHER-RETAINER 2"
- #18- PN 10232 NIPPLE-1" X 2"
- #19- ADAPTER-1/2MP X 1/2MP

HOSE ASSEMBLY NOTES:
 A. HOSE O/A LENGTH TO BE 10 FT.
 B. THIS END OF HOSE TO PROTRUDE 1/16" PAST PN 11021 FOR SEAL.

REED CONCRETE PLACING EQUIPMENT
 CHINO, CA 91710

TITLE: HYDRO-NOZZLE ASSY-2 IN
DRAWN BY: EYBARRA 7/7/2000

ECN# 202
 7/7/00
 EMY

PART NUMBER
11980
 SHT 1 OF 1

REV
A

HYDRO NOZZLE (5.5 FEET)

Available in 1.25"

Hamm (11981) complete assembly

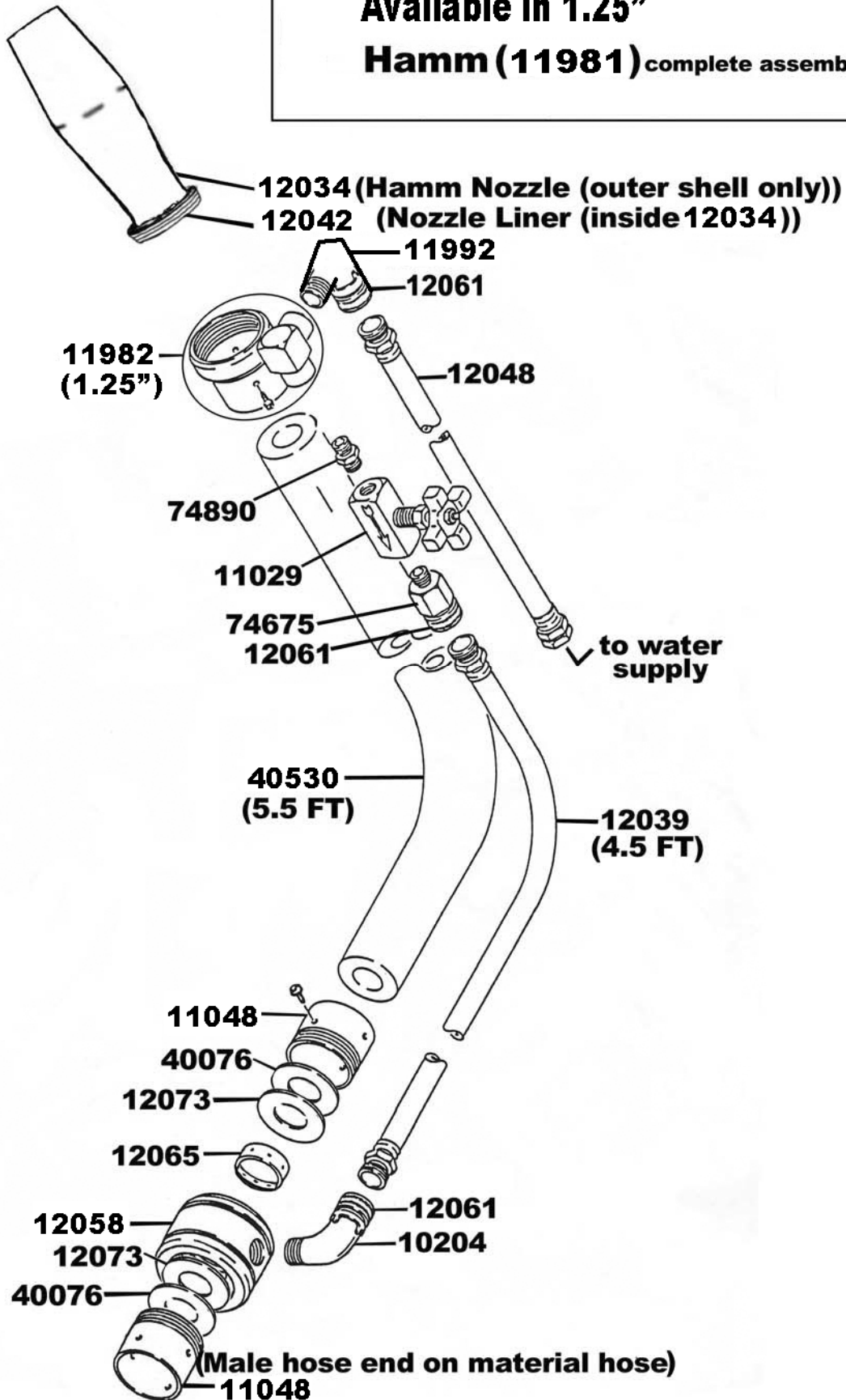

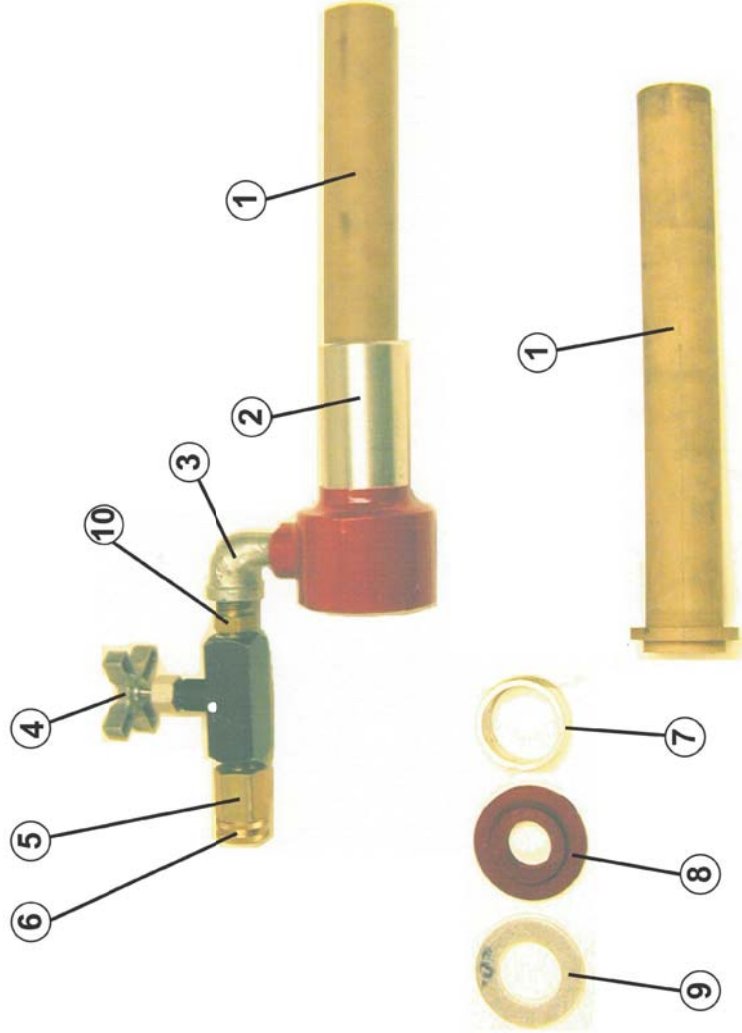
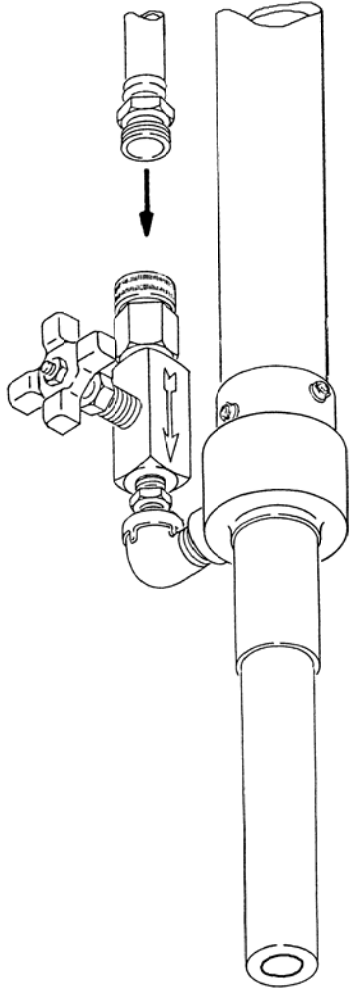

BILL of MATERIALS

#	2-PN 12052 BODY-NOZZLE 3/4" & 1" FINE (QTY-1)
#	3-PN 10204 STREET ELBOW 90 -1/2" (QTY-1)
#	4-PN 11029 VALVE NEEDLE-3/8" (QTY-1)
#	5-PN 74675 REDUCER-1/2" TO 3/8" (QTY-1)
#	6-PN 12061 ADAPTER-1/2" TO 3/4" (QTY-1)
#	7-PN 12064 WATER RING-1" (QTY-1)
#	8-PN 12070 WASHER-BACKUP "FINE" (QTY-1)
#	9-PN 12080 WASHER-RETAINER 1 1/4" (QTY-1)
#	10-PN 74890 ADAPTER-1/2" x 3/8" (QTY-1)

REED CONCRETE PLACING EQUIPMENT
 CHINO, CA 91710

TITLE: NOZZLE ASSY-FINE 3/4"
 DRAWN BY: EYBARRA 9/02/03

PART NUMBER
12000
 SHT 1 OF 1

REV

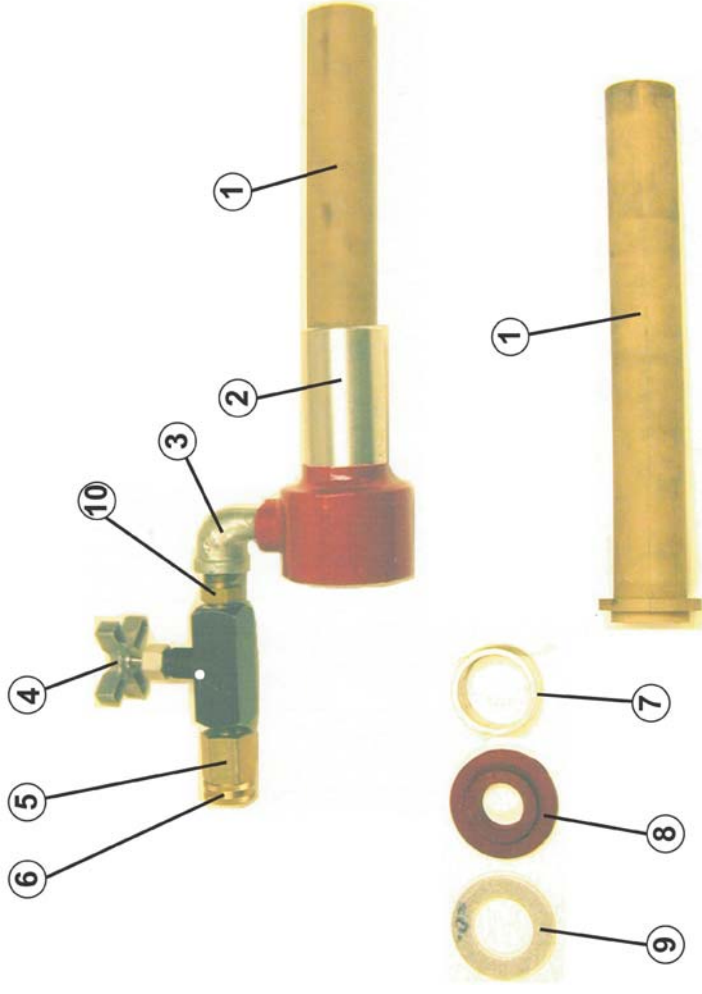
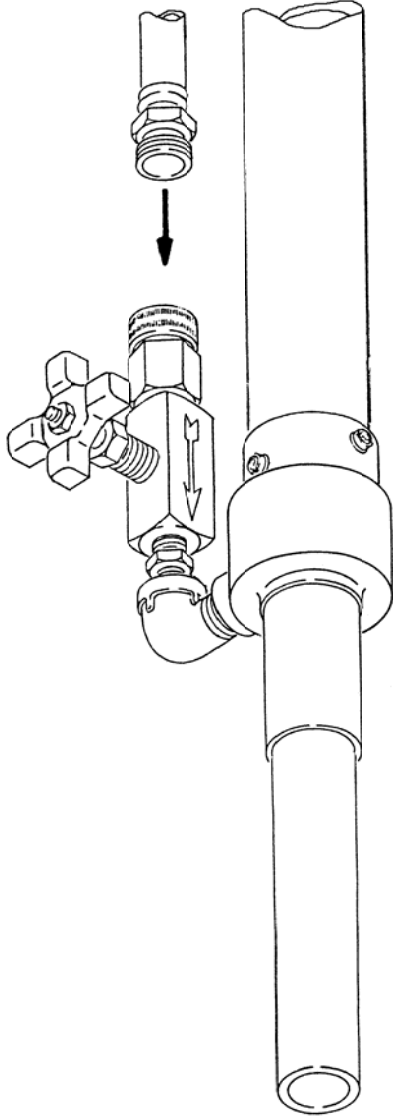

BILL of MATERIALS	
#	1-PN 12041 LINER-1" NOZZLE (QTY-1)
#	2-PN 12052 BODY-NOZZLE 1" FINE (QTY-1)
#	3-PN 10204 STREET ELBOW 90 -1/2" (QTY-1)
#	4-PN 11029 VALVE NEEDLE-3/8" (QTY-1)
#	5-PN 74675 REDUCER-1/2" TO 3/8" (QTY-1)
#	6-PN 12061 ADAPTER-1/2" TO 3/4" (QTY-1)
#	7-PN 12064 WATER RING-1" (QTY-1)
#	8-PN 12070 WASHER-BACKUP "FINE" (QTY-1)
#	9-PN 12080 WASHER-RETAINER 1 1/4" (QTY-1)
#	10-PN 74890 ADAPTER-1/2" x 3/8" (QTY-1)

REED CONCRETE PLACING EQUIPMENT CHINO, CA 91710	TITLE: NOZZLE ASSY-FINE 1" DRAWN BY: EYBARRA 8/26/03	PART NUMBER 12001 SHT 1 OF 1	REV

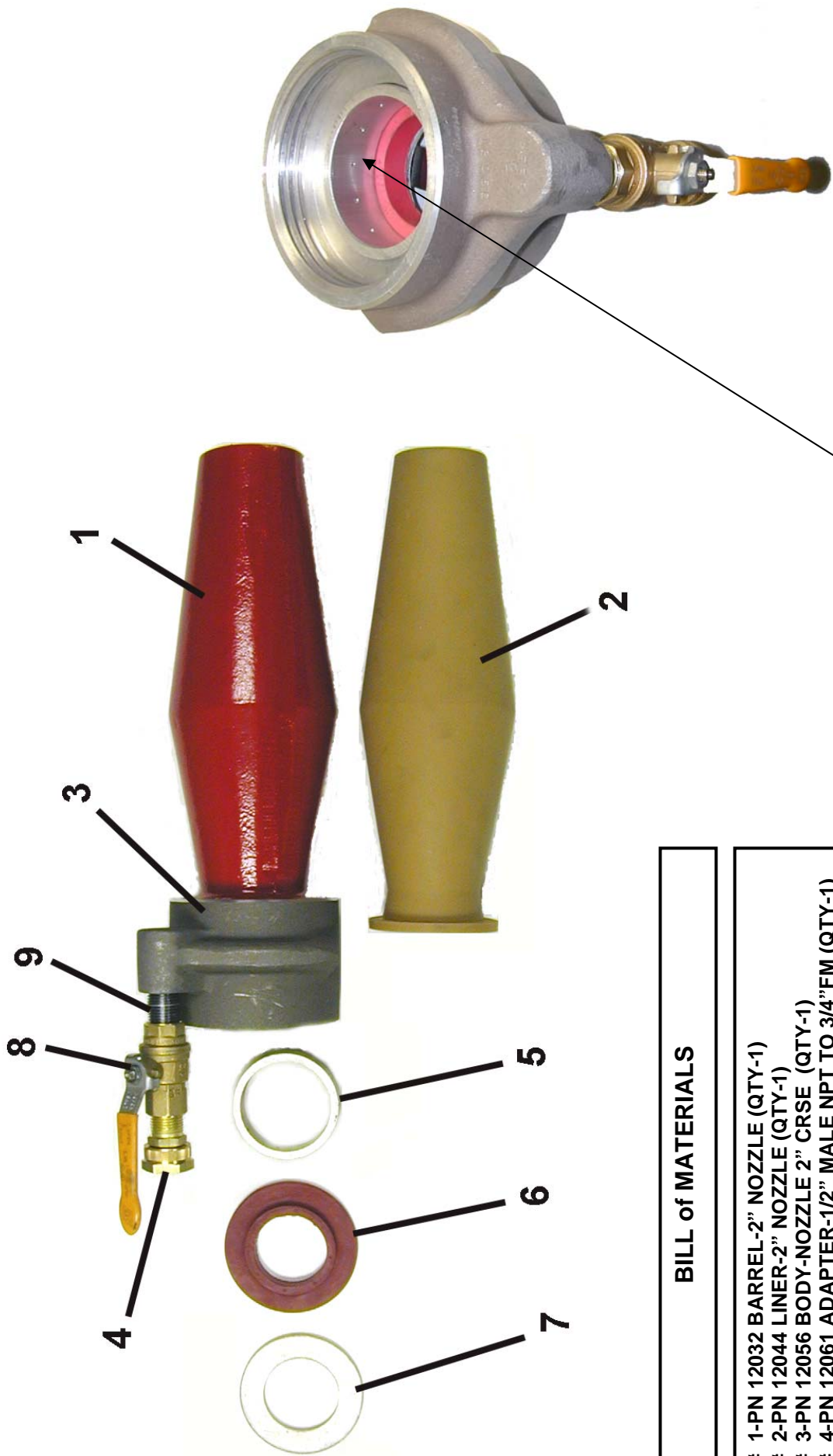

BILL of MATERIALS

- # 1-PN 12032 BARREL-2" NOZZLE (QTY-1)
- # 2-PN 12044 LINER-2" NOZZLE (QTY-1)
- # 3-PN 12056 BODY-NOZZLE 2" CRSE (QTY-1)
- # 4-PN 12061 ADAPTER-1/2" MALE NPT TO 3/4"FM (QTY-1)
- # 5-PN 12066 RING-2" WATER (QTY-1)
- # 6-PN 12074 WASHER-BACKUP 2" CRSE (QTY-1)
- # 7-PN 12083 WASHER-RETAINER 2" CRSE ALUM (QTY-1)
- # 8-PN 10270 BALL VALVE-1/2" (QTY-1)
- # 9-PN 10268 CLOSE PIPE NIPPLE-1/2" (QTY-1)

WATER RING INSTALLATION INSTRUCTIONS
 ITEM #5 WATER RING IS INSERTED INTO ITEM #3 NOZZLE BODY FROM THE NOZZLE BARREL END. (METHOD DONE SINCE 9/1990)

REED CONCRETE PLACING EQUIPMENT
 CHINO, CA 91710

TITLE: NOZZLE ASSY-CRSE 2"
 DRAWN BY: EYBARRA 11/19/04

ECN #979
 11/19/04-EMY

PART NUMBER
12005
 SHT 1 OF 1

REV
A

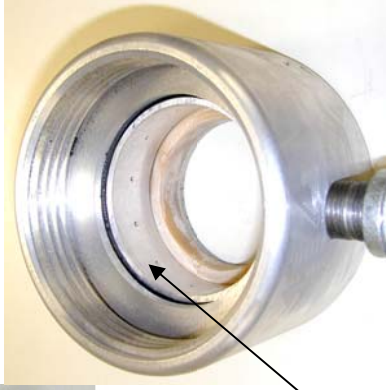
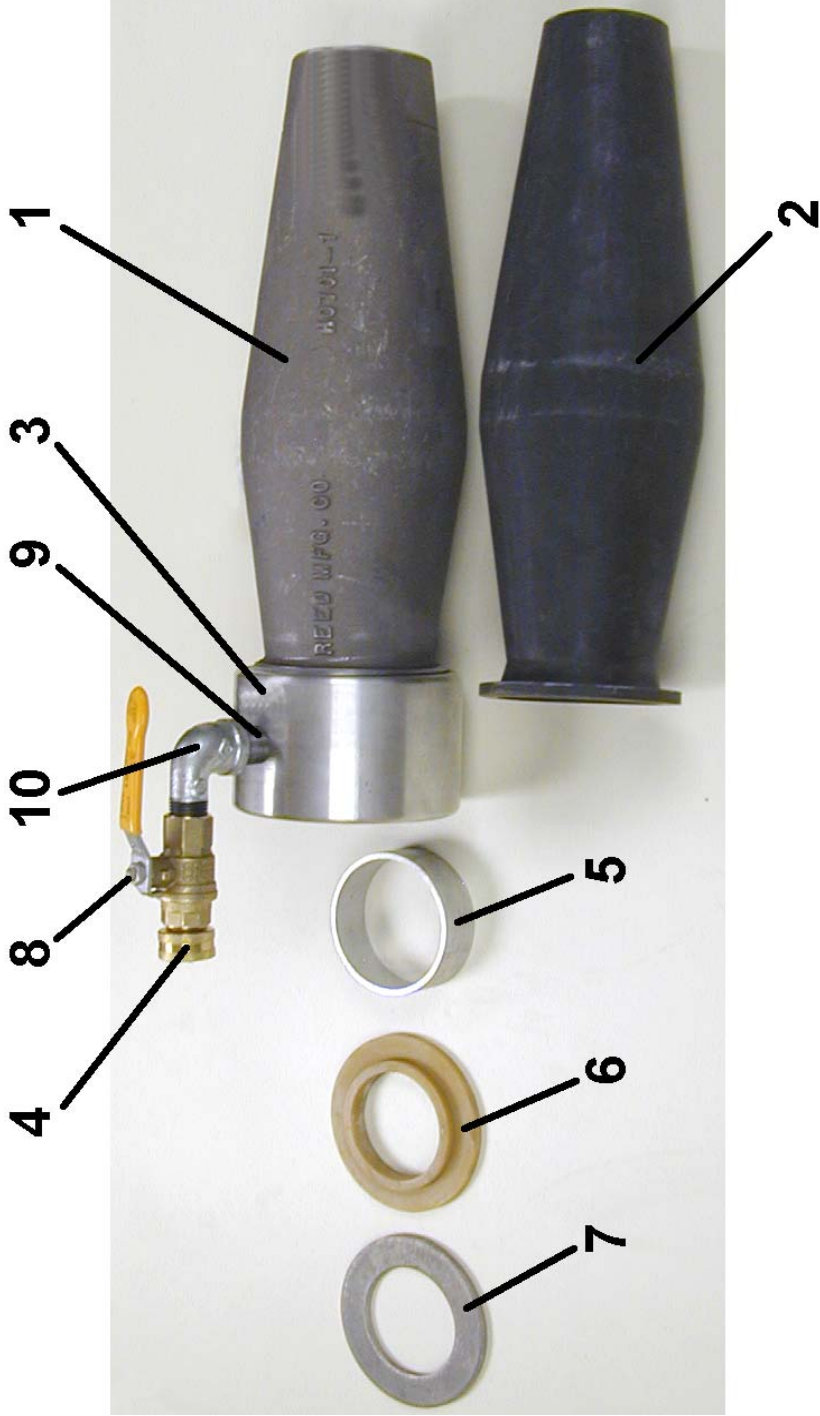

WATER RING INSTALLATION INSTRUCTIONS

ITEM #5 WATER RING IS INSERTED INTO ITEM #3 NOZZLE BODY FROM THE NOZZLE BARREL END

BILL of MATERIALS

- # 1-PN 12033 BARREL-2 1/2" NOZZLE (QTY-1)
- # 2-PN 12045 LINER-2 1/2" NOZZLE (QTY-1)
- # 3-PN 12057 BODY-NOZZLE 2 1/2" CRSE (QTY-1)
- # 4-PN 12061 ADAPTER-1/2" MALE NPT TO 3/4"FM (QTY-1)
- # 5-PN 12067 RING-2 1/2" WATER (QTY-1)
- # 6-PN 12075 WASHER-BACKUP 2 1/2" CRSE (QTY-1)
- # 7-PN 12084 WASHER-RETAINER 2 1/2" CRSE (QTY-1)
- # 8-PN 10270 BALL VALVE-1/2" (QTY-1)
- # 9-PN 10268 CLOSE PIPE NIPPLE-1/2" (QTY-1)
- # 10-PN 10204 STREET ELBOW-90-1/2" (QTY-1)

REED CONCRETE PLACING EQUIPMENT
CHINO, CA 91710

TITLE: NOZZLE ASSY-CRSE 2 1/2"
DRAWN BY: EYBARRA 11/14/07

ECN #1241
11/16/07-EMY

PART NUMBER
12006
SHT 1 OF 1

REV

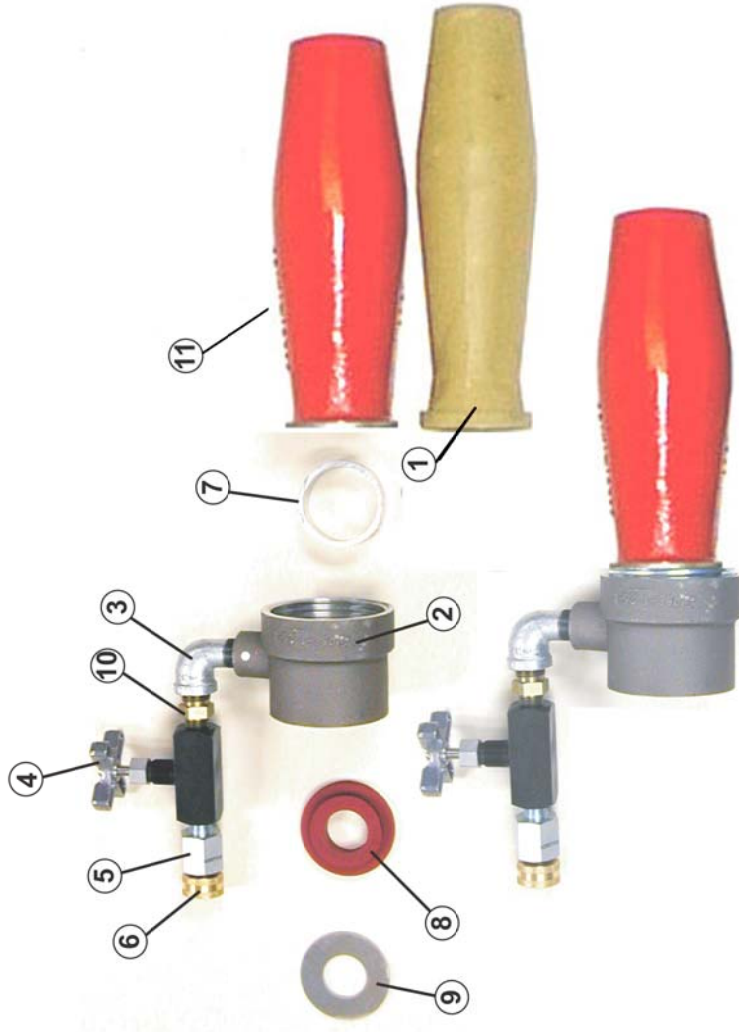
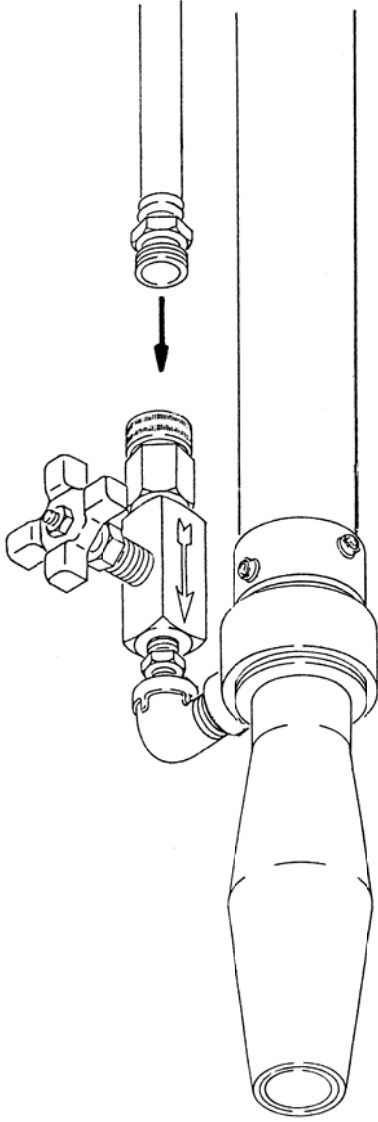

BILL of MATERIALS

- # 2-PN 12058 BODY-NOZZLE 1 1/4" CRSE (QTY-1)
- # 3-PN 10204 STREET ELBOW 90 -1/2" (QTY-1)
- # 4-PN 11029 VALVE NEEDLE-3/8" (QTY-1)
- # 5-PN 74675 REDUCER-1/2" TO 3/8" (QTY-1)
- # 6-PN 12061 ADAPTER-1/2" TO 3/4" (QTY-1)
- # 7-PN 12065 WATER RING-1 1/4" & 1 1/2" (QTY-1)
- # 8-PN 12069 WASHER-BACKUP 1 1/4" CRSE (QTY-1)
- # 9-PN 12079 WASHER-RETAINER 1 1/4" (QTY-1)
- #10-PN 74890 ADAPTER-1/2" x 3/8" (QTY-1)
- #11-PN 12035 BARREL-NOZZLE CRSE 1 1/2" (QTY-1)

REED CONCRETE PLACING EQUIPMENT
CHINO, CA 91710

TITLE: NOZZLE ASSY-COARSE 1 1/4"
DRAWN BY: EYBARRA 10/9/2008

PART NUMBER
12009
SHT 1 OF 1

REV

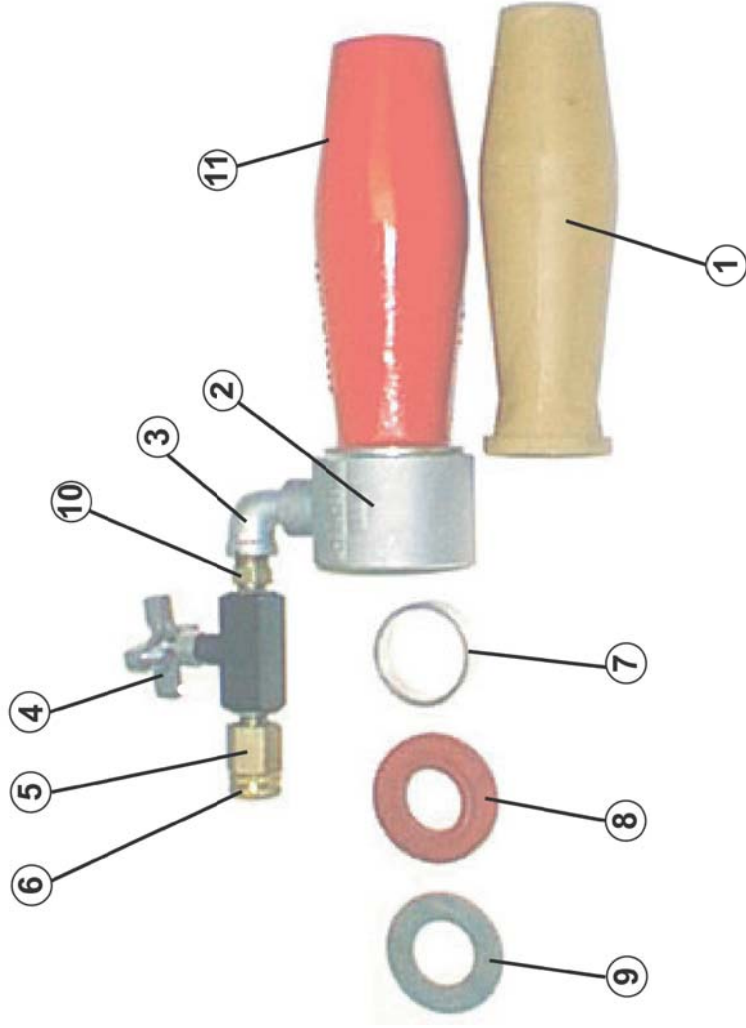
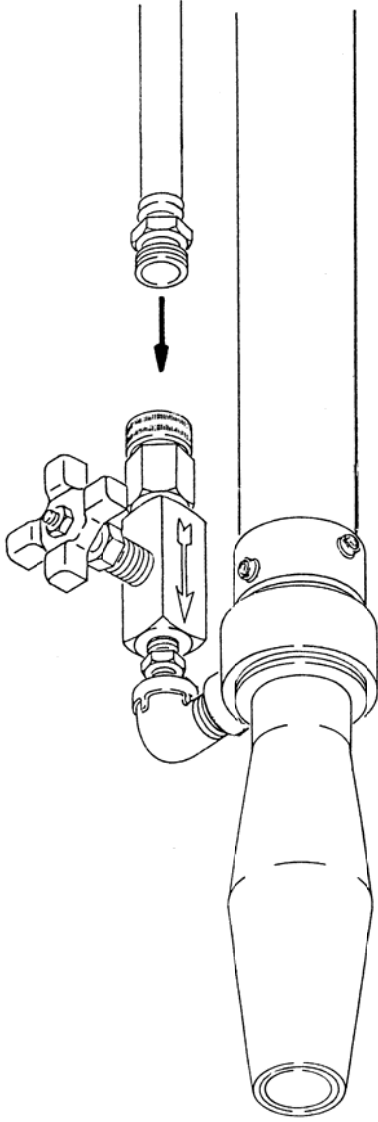

BILL of MATERIALS

- # 1-PN 12043 LINER-1 1/2" NOZZLE (QTY-1)
- # 2-PN 12059 BODY-NOZZLE 1 1/2" CRSE (QTY-1)
- # 3-PN 10204 STREET ELBOW 90 -1/2" (QTY-1)
- # 4-PN 11029 VALVE NEEDLE-3/8" (QTY-1)
- # 5-PN 74675 REDUCER-1/2" TO 3/8" (QTY-1)
- # 6-PN 12061 ADAPTER-1/2" TO 3/4" (QTY-1)
- # 7-PN 12065 WATER RING-1 1/4" & 1 1/2" (QTY-1)
- # 8-PN 12073 WASHER-BACKUP 1 1/2" CRSE (QTY-1)
- # 9-PN 40076 WASHER-RETAINER 1 1/2" (QTY-1)
- #10-PN 74890 ADAPTER-1/2" x 3/8" (QTY-1)
- #11-PN 12035 BARREL-NOZZLE CRSE 1 1/2" (QTY-1)

REED CONCRETE PLACING EQUIPMENT CHINO, CA 91710	TITLE: NOZZLE ASSY-COARSE 1 1/2" DRAWN BY: EYBARRA 8/29/03		PART NUMBER 12010 SHT 1 OF 1	REV
	[Empty Box]			

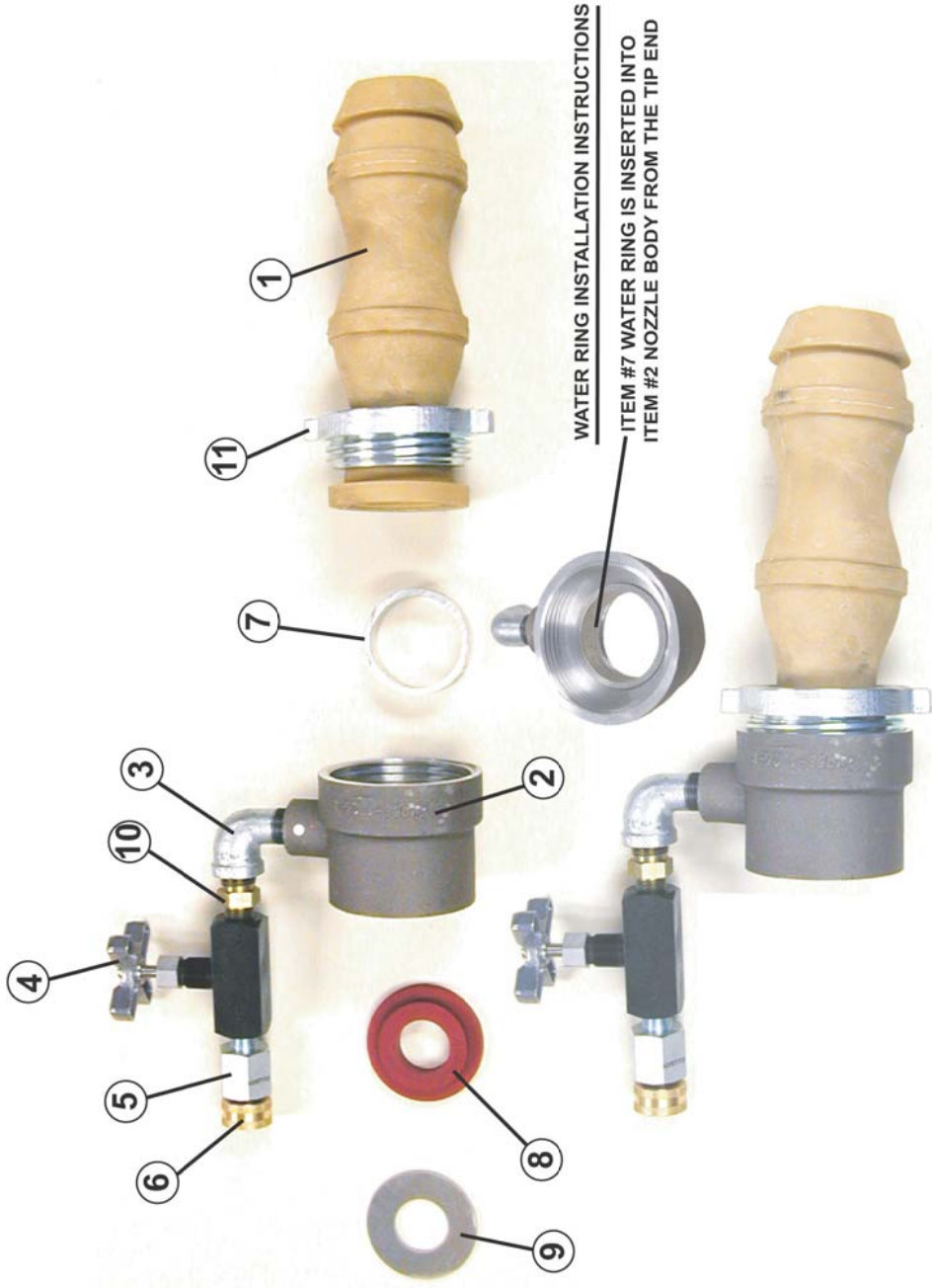

WATER RING INSTALLATION INSTRUCTIONS

ITEM #7 WATER RING IS INSERTED INTO
ITEM #2 NOZZLE BODY FROM THE TIP END

BILL of MATERIALS

- # 1-PN 12047 TIP-1 1/4" DOUBLE BUBBLE (QTY-1)
- # 2-PN 12058 BODY-NOZZLE 1 1/4" CRSE (QTY-1)
- # 3-PN 10204 STREET ELBOW 90 -1/2" (QTY-1)
- # 4-PN 11029 VALVE NEEDLE-3/8" (QTY-1)
- # 5-PN 74675 REDUCER-1/2" TO 3/8" (QTY-1)
- # 6-PN 12061 ADAPTER-1/2" TO 3/4" (QTY-1)
- # 7-PN 12065 WATER RING-1 1/4" & 1 1/2" (QTY-1)
- # 8-PN 12069 WASHER-BACKUP 1 1/4" CRSE (QTY-1)
- # 9-PN 12079 WASHER-RETAINER 1 1/4" (QTY-1)
- # 10-PN 74890 ADAPTER-1/2" x 3/8" (QTY-1)
- # 11-PN 12091 NUT-D.B. RETAINER (QTY-1)

REED CONCRETE PLACING EQUIPMENT
CHINO, CA 91710

TITLE: NOZZLE ASSY 1 1/4" DB
DRAWN BY: EYBARRA 11/16/2007

ECN#1241
11/16/07-EMY

PART NUMBER
12021
SHT 1 OF 1

REV

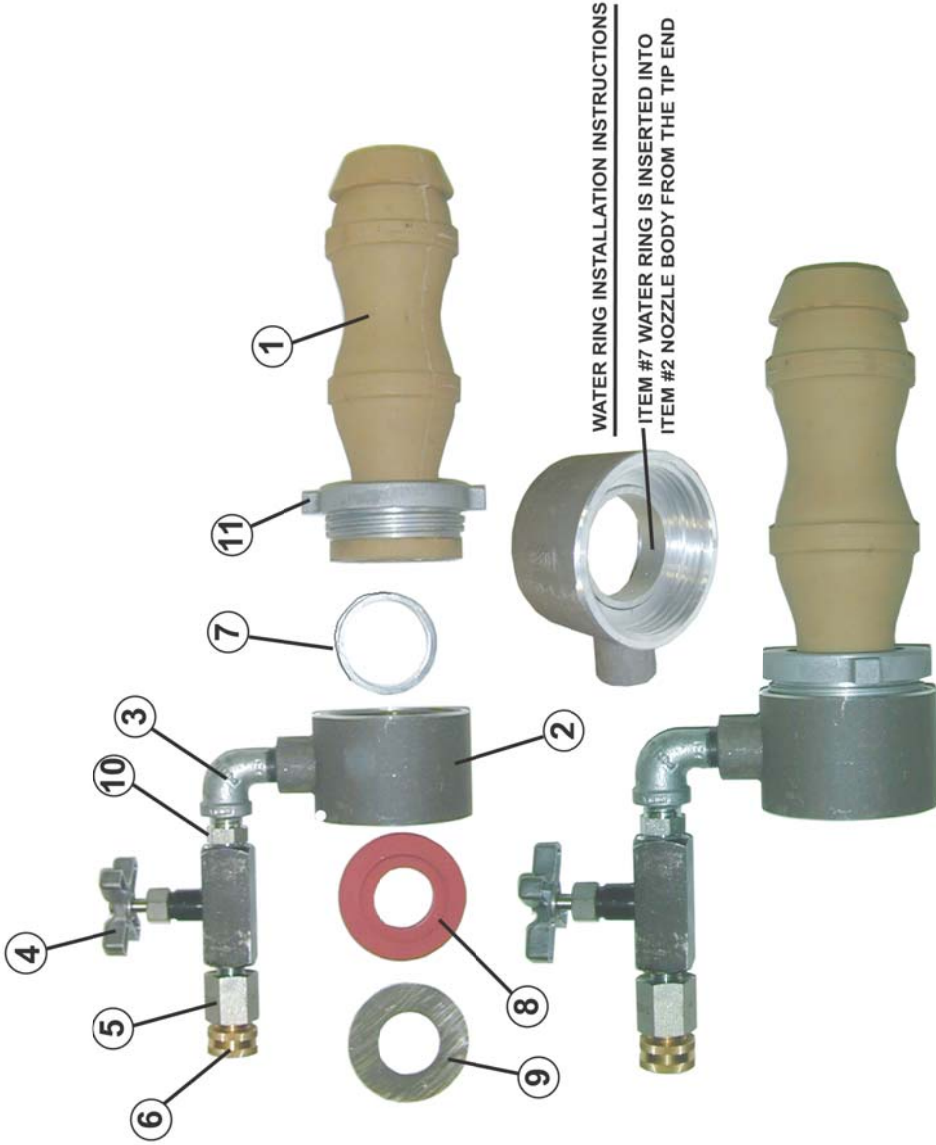

BILL of MATERIALS

- # 1-PN 12047 TIP-1 1/4" DOUBLE BUBBLE (QTY-1)
- # 2-PN 12059 BODY-NOZZLE 1 1/2" CRSE (QTY-1)
- # 3-PN 10204 STREET ELBOW 90 -1/2" (QTY-1)
- # 4-PN 11029 VALVE NEEDLE-3/8" (QTY-1)
- # 5-PN 74675 REDUCER-1/2" TO 3/8" (QTY-1)
- # 6-PN 12061 ADAPTER-1/2" TO 3/4" (QTY-1)
- # 7-PN 12065 WATER RING-1 1/4" & 1 1/2" (QTY-1)
- # 8-PN 12073 WASHER-BACKUP 1 1/2" CRSE (QTY-1)
- # 9-PN 40076 WASHER-RETAINER 1 1/2" (QTY-1)
- # 10-PN 74890 ADAPTER-1/2" x 3/8" (QTY-1)
- # 11-PN 12091 NUT-D.B. RETAINER (QTY-1)

REED CONCRETE PLACING EQUIPMENT
CHINO, CA 91710

TITLE: NOZZLE ASSY 1 1/2" DB
DRAWN BY: EYBARRA 10/09/2008

PART NUMBER
12022
SHT 1 OF 1

REV

HYDRO NOZZLE (5.5 FEET)

Available in 1.5"
Hamm (12036) complete assembly

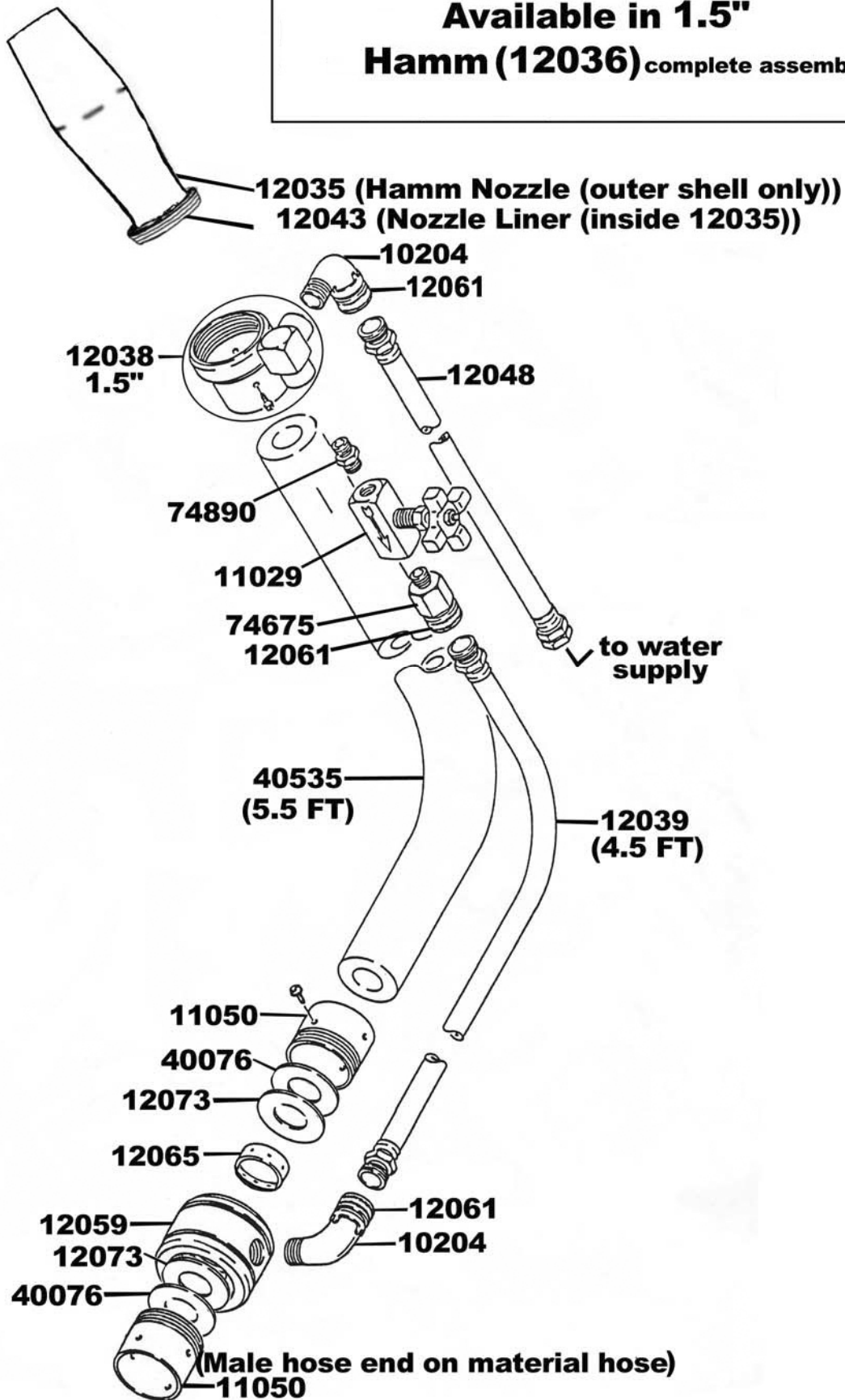

HYDRO NOZZLE (5.5 FEET)

Available in 1.5"
Double Bubble (12078) complete assembly

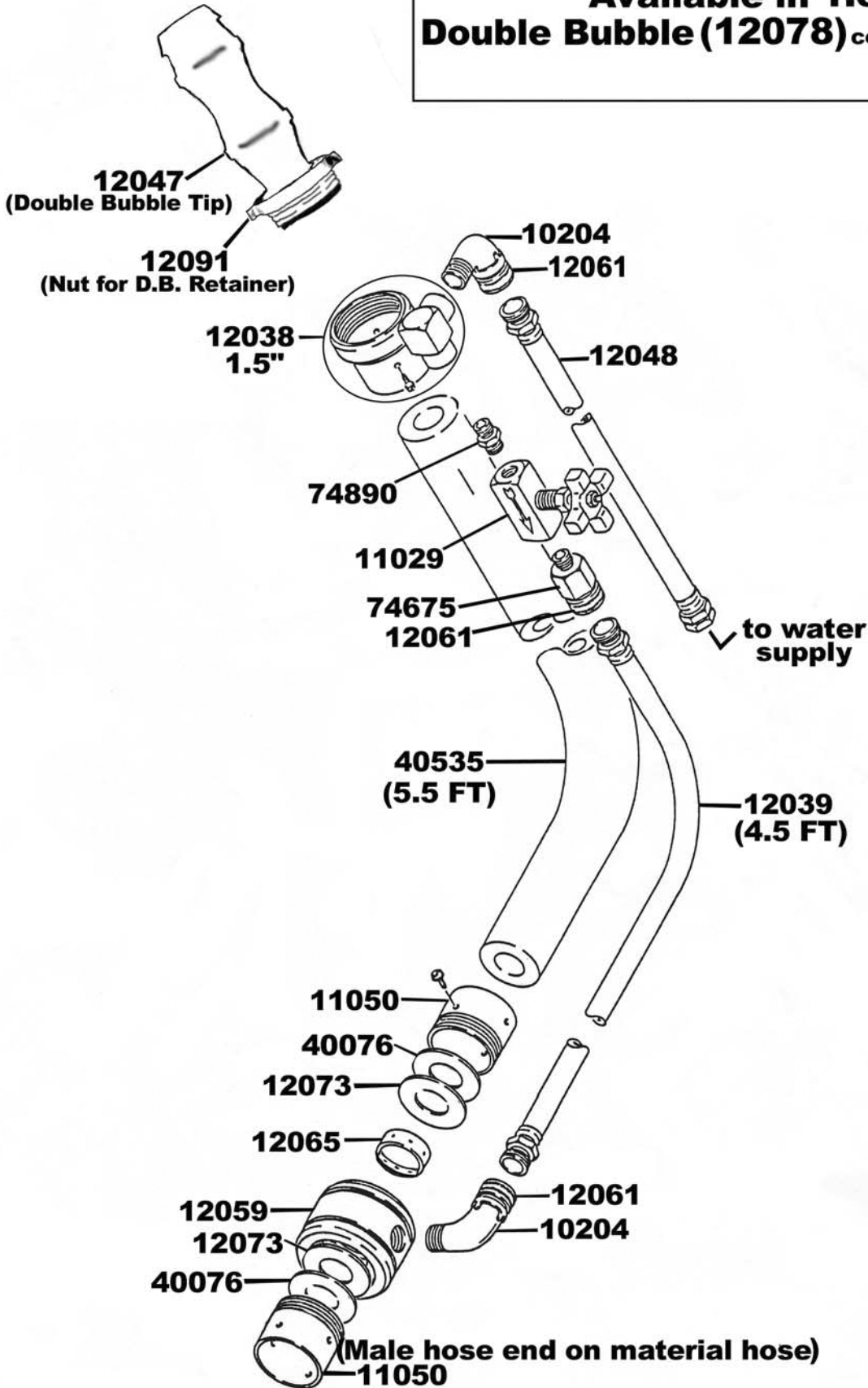

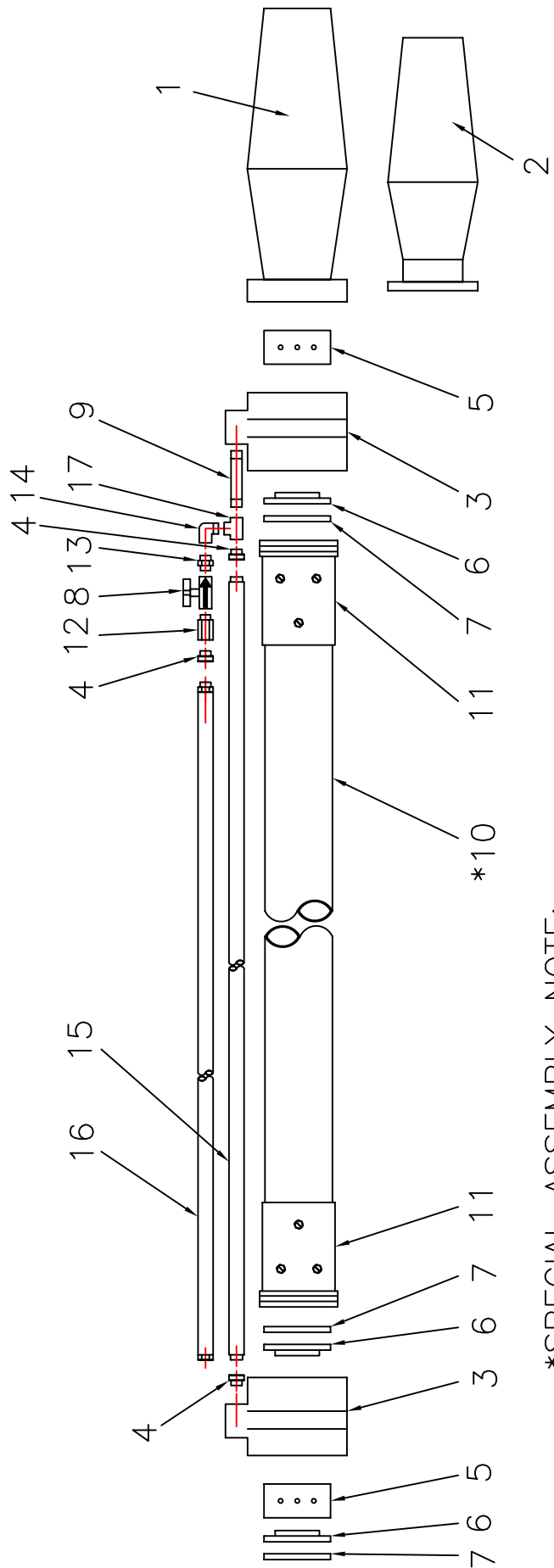

*SPECIAL ASSEMBLY NOTE:

*MUST CUT TO FIT AT ASSY IN RELATION TO ITEM #15 HOSE ASSY

BILL OF MATERIALS	
# 1-PN 12032 BARREL-2" NOZZLE (QTY-1)	#11-PN 11046 END-HOSE,MALE-CRSE 2"(QTY-2)
# 2-PN 12044 LINER-2" NOZZLE (QTY-1)	#12-PN 74675 REDUCER-1/2 NPTF X 3/8 NPTM (QTY-1)
# 3-PN 12056 BODY-NOZZLE 2" CRSE (QTY-2)	#13-PN 74890 ADAPTOR-1/2 NPTM X 3/8 NPTM (QTY-1)
# 4-PN 12061 ADAPTER-1/2" MALE NPT TO 3/4"FM (QTY-3)	#14-PN 10204 STREET ELBOW 1/2" 90(QTY-1)
# 5-PN 12066 RING-2" WATER (QTY-2)	#15-PN 12039 HOSE ASSY-(WATER) 4.5FT (QTY-1)
# 6-PN 12074 WASHER-BACKUP 2" CRSE (QTY-3)	#16-PN 12048 WATER HOSE ASSY-1 1/2" (QTY-1)
# 7-PN 12083 WASHER-RETAINER 2" CRSE ALUM (QTY-3)	#17-PN 10204 TEE 1/2"(QTY-1)
# 8-PN 11029 NEEDLE VALVE-3/8" (QTY-1)	
# 9-PN 10298 PIPE NIPPLE-1/2" X 3" (QTY-1)	
#10-PN 40449 HOSE, 2 IN GUNCRETE CONDUCT.(QTY-5.5FT)	

REED	CONCRETE PLACING EQUIPMENT	BY	TITLE	PART NUMBER	REV
	CHINO, CA 91710	EYBARRA	8/25/06	HYDRO NOZZLE ASSY-2"x5.5FT-(DBL WATER RING)	12092

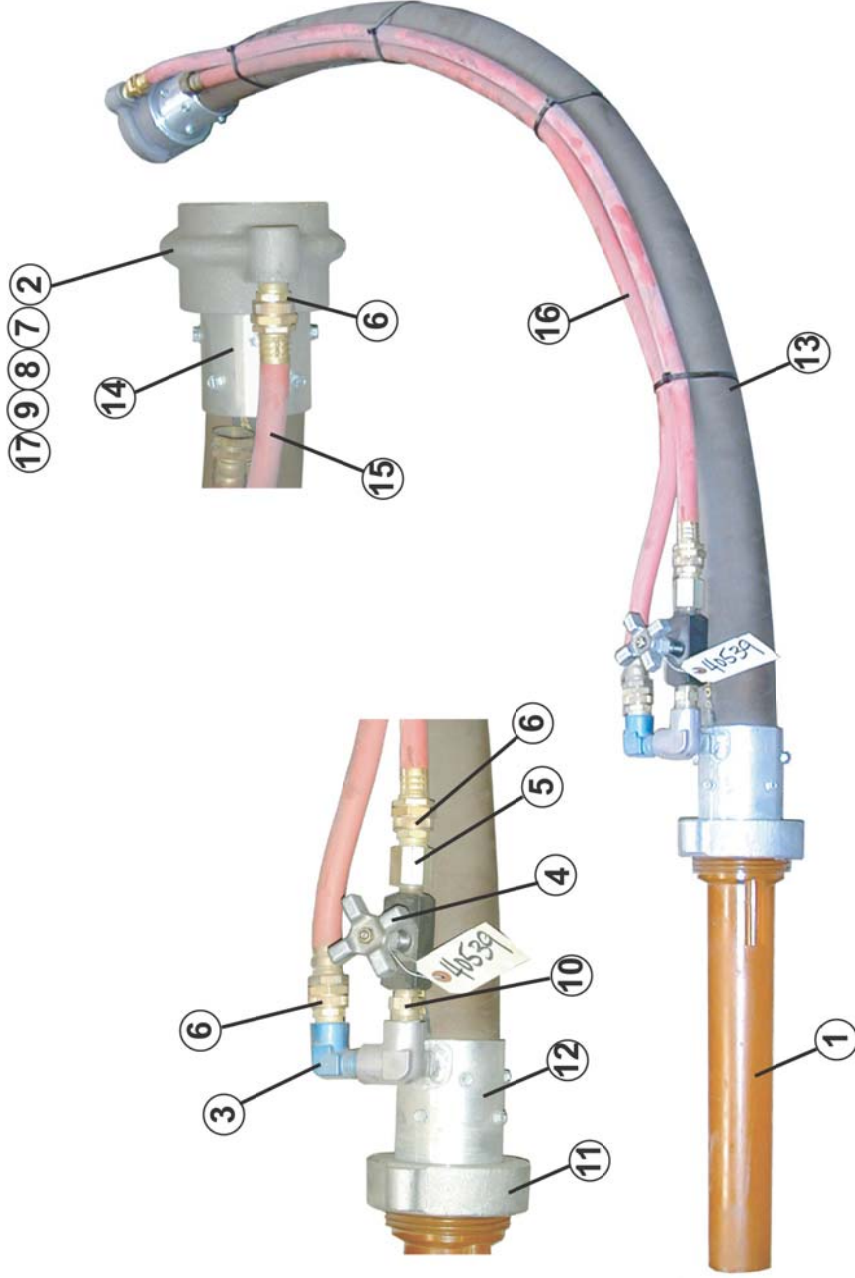

BILL of MATERIALS

- | | |
|---|--|
| # 1-PN 12004 TIP-2" (QTY-1) | # 9-PN 12083 WASHER-RETAINER 2 CRSE" (QTY-1) |
| # 2-PN 12056 BODY-NOZZLE 2" CRSE (QTY-1) | # 10-PN 74890 ADAPTER-1/2" x 3/8" (QTY-1) |
| # 3-PN 11992 ST. ELBOW 90 ALUM-1/2" (QTY-1) | # 11-PN 12091 NUT-D.B. RETAINER (QTY-1) |
| # 4-PN 11029 VALVE NEEDLE-3/8" (QTY-1) | # 12-PN 11995 HOSE END WELD-2" HYD NOZZLE (QTY-1) |
| # 5-PN 74675 REDUCER-1/2" TO 3/8" (QTY-1) | # 13-PN 40449 HOSE, 2" GUNCRETE CONDUCTIVE (QTY-5.5FT) |
| # 6-PN 12061 ADAPTER-1/2" TO 3/4" (QTY-3) | # 14-PN 11046 END-HOSE, MALE-CRSE 2" (QTY-1) |
| # 7-PN 12066 WATER RING-2" (QTY-1) | # 15-PN 12039 HOSE ASSY-(WATER) 4.5FT (QTY-1) |
| # 8-PN 12074 WASHER-BACKUP 2" CRSE (QTY-2) | # 16-PN 12048 WATER HOSE ASSY-1/2" (QTY-1) |
| | # 17-PN 74679 PLUG-1/4NPT SOCKET HEAD (QTY-2) |

REED CONCRETE PLACING EQUIPMENT
CHINO, CA 91710

TITLE: HYDRO NOZZLE ASSY-2 INCH FRONT VALVE
DRAWN BY: EYBARRA 10/09/2008

PART NUMBER
40539
SHT 1 OF 1

REV











GUNITE TOOLS AND SUPPLIES

CATEGORY	PART#	DESCRIPTION
CATEGORY	PART#	DESCRIPTION
SPIROLET NOZZLE	40821	2" NOZZLE TIP
		(OTHER SIZES AND ASSEMBLIES AVAILABLE UPON REQUEST)
CATEGORY	PART#	DESCRIPTION
AIR HOSE	40591	2" X 50' COUPLED WITH DIXON BOSS FITTINGS – 150 PSI
	40593	1½" X 50' COUPLED WITH DIXON BOSS FITTINGS – 150 PSI
CATEGORY	PART#	DESCRIPTION
WATER/AIR HOSE	40590	¾" X 50' COUPLED WITH BRASS WATER FITTINGS – 150 PSI
	40589	¾" WATER COUPLINGS (LONG STEM)
CATEGORY	PART#	DESCRIPTION
SHOOTING WIRE	40600	.0348 SHOOTING WIRE (SOLD BY THE POUND) (AVERAGE WEIGHT PER ROLL – 46-48 LBS)
	40601	16½ GAUGE TIE WIRE (3.5 LBS ROLL)



GUNITE TOOLS AND SUPPLIES

CATEGORY	PART#	DESCRIPTION
GUNITE TOOLS	40615	24" GUNITE CUTTING ROD
	40620	36" GUNITE CUTTING ROD
	40625	48" GUNITE CUTTING ROD
	40635	24" STRAIGHT FRESNO – SQUARE ENDS
	40640	24" STRAIGHT FRESNO – ROUND ENDS
	40645	24" CURVED FRESNO – STRAIGHT ENDS
	40650	24" CURVED FRESNO – ROUND ENDS
	40655	30" STRAIGHT FRESNO – STRAIGHT ENDS
	40660	30" STRAIGHT FRESNO – ROUND ENDS
	40665	30" CURVED FRESNO – STRAIGHT ENDS
	40670	30" CURVED FRESNO – ROUND ENDS
	40675	6' WOOD FRESNO HANDLE
	40680	12" X 5" METAL FINISHING TROWEL
	40685	12" X 4" METAL FINISHING TROWEL
	40690	5" X 2" MARGIN TROWEL
	40695	12" X 4" WOOD FLOAT
	40700	14" X 4" WOOD FLOAT
	40705	16" X 3½" WOOD FLOAT

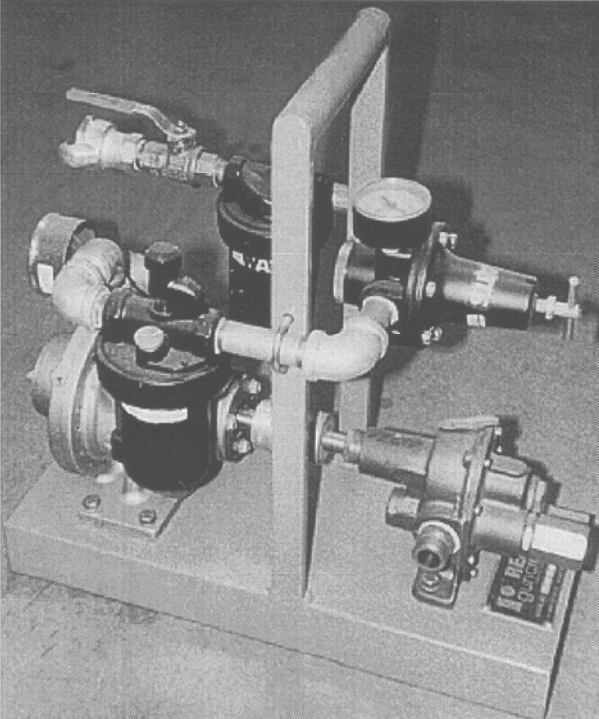
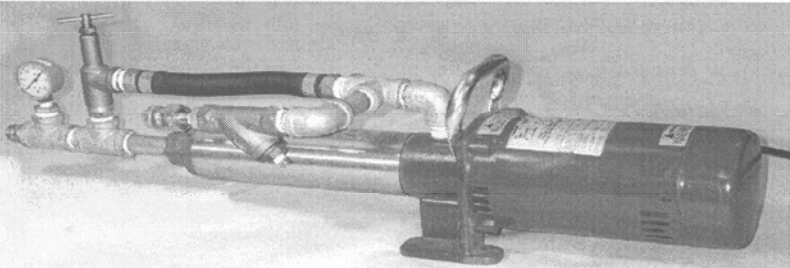

BOOSTER PUMPS

CATEGORY	PART#	DESCRIPTION
<p>AIR DRIVEN</p>  A black and white photograph of an air-driven booster pump assembly. It features a vertical metal frame supporting a pump unit with various pipes, valves, and a pressure gauge. The pump is mounted on a base plate.	4025	ROTARY GEAR, POSITIVE DISPLACEMENT PUMP, MAXIMUM DISCHARGE PRESSURE: 120 PSI (8.3 BAR), MAXIMUM SUCTION LIFT: 20 FEET (6M), ADJUSTABLE DISCHARGE PRESSURE RELIEF, PIPE SIZE: 3/4" (19mm) USED PRIMARILY IN GUNNING APPLICATIONS TO PROVIDE STABLE WATER PRESSURE AT NOZZLE.
<p>ELECTRIC DRIVEN</p>  A black and white photograph of an electric driven booster pump assembly. It consists of a horizontal metal pipe with a pump unit at the end, connected to a black electric motor. There are various fittings, valves, and a pressure gauge on the pipe.		MODEL BP250, PRESSURE TO 250 PSI (17.5 BAR), CAPACITIES TO 8 GPM (30.3 LPM), POWER SOURCE: ELECTRIC STANDARD, 115 OR 230 VOLT/60Hz, 1 PHASE, BY-PASS PRESSURE RELIEF VALVE ASSEMBLY, PIPE SIZE: 3/4" NPT





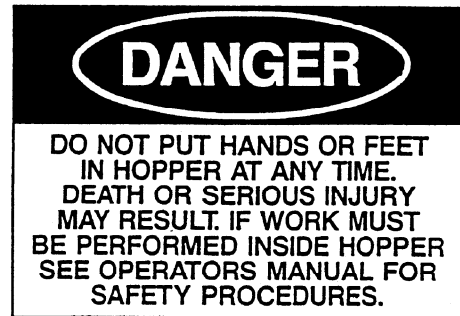

SAFETY DECALS

CATEGORY	PART#	QTY	DESCRIPTION
	10838	2	WARNING – SAFETY GLASSES
	10833	2	REED GUNCRETE
	10839	1	WARNING WEAR PAD
	10840	1	WARNING – INSIDE HOPPER
	10842	2	CAUTION – DO NOT LIFT HANDLES
	75005	2	NO HANDS SYMBOLS



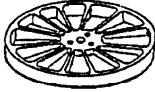

RECOMMENDED SPARE PARTS - LOVA/LOHE

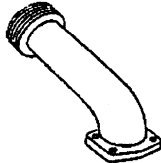
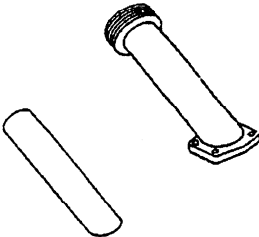
PART#	DESCRIPTION	QTY
10796	12 PKT W/DIVIDERS WEAR PLATE	2
10797	12 PKT W/DIVIDERS FEED BOWL	1
10336	WEAR PAD	60
		
10798	12 PKT DIVIDERLESS WEAR PLATE	2
10799	12 PKT DIVIDERLESS FEED BOWL	1
10336	WEAR PAD	60
		
10802	15 PKT LA WEAR PLATE	2
10803	15 PKT LA FEED BOWL	1
10336	WEAR PAD	60
		
10800	15 PKT STANDARD WEAR PLATE	2
10801	15 PKT STANDARD FEED BOWL	1
10338	WEAR PAD	60
		
10805	20 PKT WEAR PLATE	2
10806	20 PKT FEED BOWL	1
10338	WEAR PAD	60
10807	21 PKT WEAR PLATE	2
10808	21 PKT FEED BOWL	1
10339	WEAR PAD	60
		
10809	30 PKT FEED BOWL	1
10339	WEAR PAD	60
10042	1 1/2" L.T. GOOSENECK	1
10959	1 1/2" GOOSENECK LINER	5
10043	1 1/4" SOLID GOOSENECK	1
10044	1 1/2" SOLID GOOSENECK	1
		
10045	2" SOLID GOOSENECK	1
10046	2" L.T. GOOSENECK	1
10958	2" GOOSENECK LINER	5
		
10605	8AM AIR MOTOR REPAIR KIT	1
10606	16AM AIR MOTOR REPAIR KIT	1







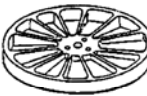

RECOMMENDED SPARE PARTS - LOVA/LOHE

PART#	DESCRIPTION	QTY
10825	RISER PLATE - MEDIUM	2
10826	RISER PLATE - THICK	2
10827	RISER PLATE - THIN	2
10728	SPINDLE STUD	6
10005	FELT SEAL	5
10013	ROCK SHEAR - WIDE	1
10014	ROCK SHEAR - NARROW	1
	<u>ADDITIONAL PARTS FOR LOHE</u>	
10618	VARIABLE SPEED BELT (NORDGEAR MOTOR ASSEMBLY)	1
10102	VARIABLE SPEED BELT (BALDOR MOTOR)	1
	NOTE: WEAR PATE, FEED BOWL AND GOOSENECK WILL BE DETERMINED BY THE MACHNE SYSTEM SETUP.	



RECOMMENDED SPARE PARTS LOVA/LOHE SERIES IV

PART#	DESCRIPTION		QTY
10796	12 PKT W/DIVIDERS WEAR PLATE		2
10797	12 PKT W/DIVIDERS FEED BOWL		1
10783	12 PKT ROTARY FEED WHEEL		1
10336	WEAR PAD		60
10798	12 PKT DIVIDERLESS WEAR PLATE		2
10799	12 PKT DIVIDERLESS FEED BOWL		1
10336	WEAR PAD		60
10802	15 PKT LA WEAR PLATE		2
10803	15 PKT LA FEED BOWL		1
10780	15 PKT LA ROTARY FEED WHEEL		1
10336	WEAR PAD		60
10800	15 PKT STANDARD WEAR PLATE		2
10801	15 PKT STANDARD FEED BOWL		1
10781	15 PKT STANDARD ROTARY FEED WHEEL		1
10338	WEAR PAD		60
10805	20 PKT WEAR PLATE		2
10806	20 PKT FEED BOWL		1
10779	20 PKT ROTARY FEED WHEEL		1
10338	WEAR PAD		60
10807	21 PKT WEAR PLATE		2
10808	21 PKT FEED BOWL		1
10778	21 PKT ROTARY FEED WHEEL		1
10339	WEAR PAD		60
10809	30 PKT FEED BOWL		1
10339	WEAR PAD		60
10042	1 1/2" L.T. GOOSENECK		1
10959	1 1/2" GOOSENECK LINER		5
10043	1 1/4" SOLID GOOSENECK		1
10044	1 1/2" SOLID GOOSENECK		1
10045	2" SOLID GOOSENECK		1



RECOMMENDED SPARE PARTS
LOVA/LOHE SERIES IV

PART#	DESCRIPTION	QTY
10046	2" L.T. GOOSENECK	1
10958	2" GOOSENECK LINER	5
10605	8AM AIR MOTOR REPAIR KIT	1
10606	16AM AIR MOTOR REPAIR KIT	1
10825	RISER PLATE - MEDIUM	2
10826	RISER PLATE - THICK	2
10827	RISER PLATE - THIN	2
10728	SPINDLE STUD	6
10005	FELT SEAL	5
10013	ROCK SHEAR - WIDE	1
10014	ROCK SHEAR - NARROW	1
	<u>ADDITIONAL PARTS FOR LOHE</u>	
10618	VARIABLE SPEED BELT (NORDGEAR MOTOR ASSEMBLY)	1
10102	VARIABLE SPEED BELT (BALDOR MOTOR)	1
	NOTE: WEAR PATE, FEED BOWL AND GOOSENECK WILL BE DETERMINED BY THE MACHNE SYSTEM SETUP.	



RECOMMENDED SPARE PARTS - SOVA/SOVE

PART#	DESCRIPTION	QTY
20089	16 POCKET FEED BOWL	1
20189	18 POCKET FEED BOWL	1
20097	1 1/2" L.T. GOOSENECK	1
20086	1 1/2" GOOSENECK LINER	5
10044	1 1/2" SOLID GOOSENECK	1
10043	1 1/4" SOLID GOOSENECK	1
20090	WEAR PAD	50
20172	RISER PLATE - THIN	2
20173	RISER PLATE - MEDIUM	2
20174	RISER PLATE - THICK	2
20388	ROCK SHEAR	1
20158	FELT SEAL	5
10605	8AM AIR MOTOR REPAIR KIT	1
10618	VARIABLE SPEED BELT (ELECTRIC DRIVE ONLY)	1 1
<p>NOTE: FEED BOWL AND GOOSENECK WILL BE DETERMINED BY THE MACHNE SYSTEM SETUP.</p>		



RECOMMENDED SPARE PARTS - 209A/209E

PART#	DESCRIPTION	QTY
20089	16 POCKET FEED BOWL	1
20189	18 POCKET FEED BOWL	1
20097	1 1/2" L.T. GOOSENECK	1
20086	1 1/2" GOOSENECK LINER	5
10044	1 1/2" SOLID GOOSENECK	1
10043	1 1/4" SOLID GOOSENECK	1
20090	WEAR PAD	50
20172	RISER PLATE - THIN	2
20173	RISER PLATE - MEDIUM	2
20174	RISER PLATE - THICK	2
20388	ROCK SHEAR	1
20158	FELT SEAL	5
10965	DUST BAG	1
10605	8AM AIR MOTOR REPAIR KIT	1
10618	VARIABLE SPEED BELT (ELECTRIC DRIVE ONLY)	1
		1

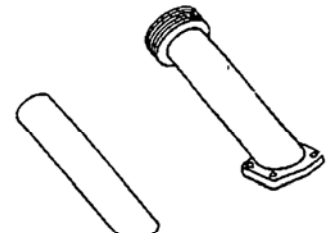

**NOTE: WEAR PATE, FEED BOWL AND GOOSENECK
WILL BE DETERMINED BY THE MACHNE
SYSTEM SETUP.**



RECOMMENDED SPARE PARTS - 215A/215E

PART#	DESCRIPTION	QTY
10780	15 PKT LA ROTARY FEED WHEEL	1
10333	WEAR PAD	60
10781	15 PKT STANDARD ROTARY FEED WHEEL	1
10334	WEAR PAD	60
10778	20 PKT ROTARY FEED WHEEL	1
10334	WEAR PAD	60
10783	12 PKT ROTARY FEED WHEEL	1
10333	WEAR PAD	60
10042	1 1/2" L.T. GOOSENECK	1
10959	1 1/2" GOOSENECK LINER	5
10043	1 1/4" SOLID GOOSENECK	1
10044	1 1/2" SOLID GOOSENECK	1
10045	2" SOLID GOOSENECK	1
10046	2" L.T. GOOSENECK	1
10958	2" GOOSENECK LINER	5
10323	DUST BAG	1
10325	DUST BAG CLAMP	1
10825	RISER PLATE - MEDIUM	2
10826	RISER PLATE - THICK	2
10827	RISER PLATE - THIN	2
10728	SPINDLE STUD	6
13011	FELT SEAL	5
10606	16AM AIR MOTOR REPAIR KIT	1
13223	ROCK SHEAR - WIDE	1
13224	ROCK SHEAR - NARROW	1
10618	VARIABLE SPEED BELT (ELECTRIC DRIVE ONLY)	1

**NOTE: WEAR PATE, FEED BOWL AND GOOSENECK WILL BE
DETERMINED BY THE MACHNE SYSTEM SETUP.**



LOVA 8 TO LOVA 16 CHANGEOVER

PART#	DESCRIPTION	QTY
10603	16AM AIR MOTOR	1
10035	16AM ADAPTER PLATE	1
10036	16AM GASKET	1
10345	MUFFLER WELDMENT	1
10304	1 1/4" X 90 DEGREE ELBOW	1
10265	1 1/4" NIPPLE	1
10344	LOCKWASHER	1
10088	16AM AIR INLET ASSEMBLY	1
NPN	1 X 3/8" DOWEL PIN	2
NPN	1 X 1/16" HEX SCREW	4



THIS PAGE INTENTIONALLY LEFT BLANK.



LOHE - PNEUMATIC SPRAYING MACHINE VENDOR SECTION

LOHE
VENDOR

FIGURE 00
PAGE 00

REED PNEUMATIC SPRAYING MACHINE MODEL **LOHE** VENDOR
SECTION CONTAINS THE FOLLOWING FIGURES:

- FIGURE 00 TABLE OF CONTENTS
- FIGURE 01 NORD GEAR
- FIGURE 02 NONE

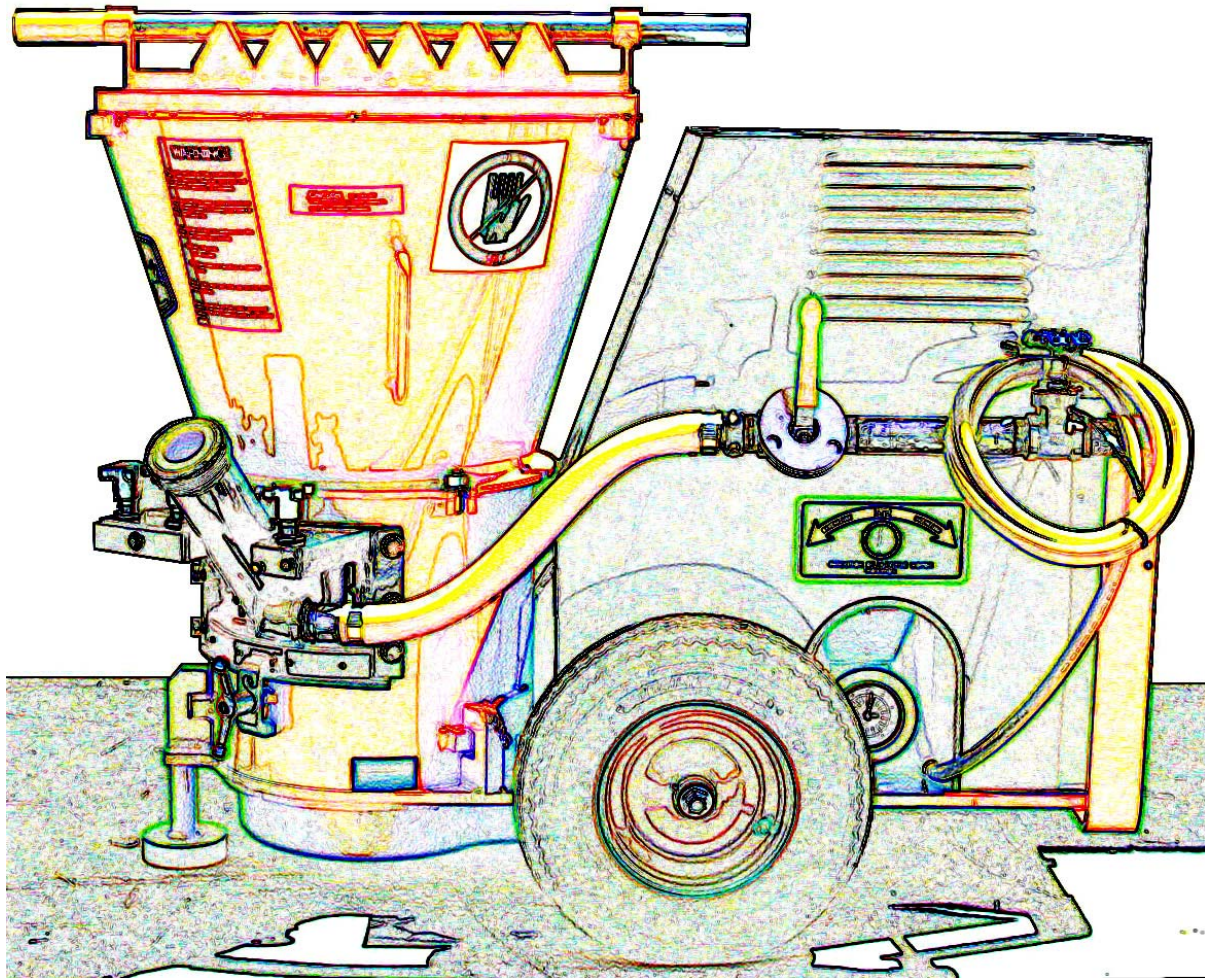

REVISION:

REED MANUFACTURING

Electric powered Reed guncrete machines furnished with three phase, 50/60 cycle electric drive motors are equipped with a solid state adjustable three phase motor protective relay. These relays are furnished to match the voltage requirements as specified, for each Reed machine ordered.

This device is installed as a protective measure and is located inside the control box directly beneath the electric drive motor.

When properly adjusted (see following instructions) for local operational power source conditions, the adjustable relay within the device will open, and cut off electric power to the drive motor should any of the following occur:

1. Prevents burn-outs in 3-phase induction motors.
2. Wide setting ranges - rated current (1 to 160A) and operating time (2 to 40 seconds).
3. Protect delta - connected motors against open phase in the 3-phase circuit.
4. Prevents the motor from reversing without starting it.
5. Stable operation against noise, induction, and current wave form distortion.

Due to the fact that variations in electrical source power exist world wide, it is recommended that the attached pre-operation test procedures be carried out before this electric powered Reed guncrete machine is put into service.

NOTE:

CAUTION

Failure to comply with this recommended test procedure can cause serious damage to the Reed machine and could void the manufacturers warranty.

REED MANUFACTURING

The following test procedure must be made to all Reed guncrete machines powered by 3 phase electric drive motors, both 3 and 5 horsepower, 50/60 cycle, before attempting to put the machines into operation.

A. PHASE REVERSAL CHECK

Steps No. 1A, 2A and 3A are to be followed with no electric power supplied to the machine.

Step No.1A - Remove (by lifting) the entire sheet metal protective cover off the machines and set it aside. This exposes the drive motor, the vari-speed pulleys and drive belt, and the electric control and switch plate panel beneath the drive motor.

Step No.2A - Remove the four (4) switch plate mounting screws and withdraw the plate outward and downward to expose the interior of the switch box beneath the drive motor.

The built-in solid state motor protective relay is mounted vertically in the center of the switch box. (It is not necessary to remove the device from its base mounting to make any adjustments).

Step No.3A - With on-site or source electric power in "OFF" position, connect the bare motor lead wires from the Reed machine in accordance with the electric wiring diagram attached to these instructions.

Step No.4A - Turn on-site or source electric power to "ON" position.

CAUTION - DO NOT OPERATE THE MAIN "ON/OFF" SWITCH ON THE REED MACHINE UNTIL THE FOLLOWING STEPS ARE COMPLETED.



Step No.5A - With electric power now connected to motor leads, make sure wiring is grounded.

Step No.6A - Using a small phillips screwdriver, remove the clear plastic cover of motor protective relay. (This step should be followed only if the voltage and current ratings are different to set ratings by Reed Manufacturing or faster response time is required).

Step No.7A - The main "ON/OFF" power switch mounted on the switch plate of the Reed machine may now be safely operated.

Step No.8A - If the unit does not start and the test button has been tripped change the phase sequence of 3 phase voltage, press and reset the test button and try step No.7A once more.

STEPS TO CONVERT LOW VOLTAGE ELECTRIC GUN TO HIGH VOLTAGE

NEVER ATTEMPT TO CONVERT AN ELECTRIC GUN FROM LOW VOLTAGE TO HIGH OR VICE VERSA, PRIOR TO READING THE INSTRUCTION MANUAL AND CONVERSION STEPS.

IN ANY CONVERSION THE FOLLOWING PARTS HAVE TO BE REPLACED, ADDED OR MODIFIED.

MOTOR PROTECTIVE RELAY	HIGH VOLTAGE	SEK4	#10118
MOTOR PROTECTIVE RELAY	LOW VOLTAGE	SEKP24	#10117 REPLACED
8 PIN SOCKET (USED WITH SEKP24 ONLY)			#10111
CURRENT CONVERTER		SET3A	#10120 MODIFIED

- 1) Turn machine off and disconnect input electric power supply.
- 2) Take off electric motor cover. On some models removal of hopper is necessary for performing this step.
- 3) Take off electric control box and mount cover.
- 4) Pull out **motor protective relay**, SEKP24 #10117, plug in type, from 8-pin socket, #10111.

The 8-pin socket will not be used with high voltage but 6 color coded wires (red, black, white, orange, green and blue) connected to 8-pin socket with insulated male ends will be used. (These extended wires are provided in late model guns, with low voltage units, to simplify the conversion procedures). If your unit does not have these wires, refer to wiring diagrams provided.

- 5) Inside the control box, we have added four color coded wires (red H₁, yellow H₃, blue H₂, white H₄) to step down transformer so you may be able to change from low voltage to high voltage input without taking the whole wiring assembly out. So for 440-480 high voltage, refer to wiring diagram and connect yellow H₃ to blue H₂ with incoming lines connected to red H₁ and white H₄.
- 6) In changing from high voltage or vice versa, you have to make sure that the number of primary conductor runs (pass) through current converter (set-3A) holes and setting tap from table below match your electric motor current.

Example: 5HP 50HZ motor will pull 14 and 7 amps at 220 and 440 voltage respectfully. If the unit is wired for low voltage 220V, it will draw 14 amps, therefore the number of conductor passes will be one. Now in switching over to high voltage 440V the unit will draw 7 amps and the number of conductor passes will be two. So you have to make sure to increase the number of passes by one when changing above mentioned unit from low to high voltage.

Table 1 - Current Setting Range

Motor Protective Relay		Current Converter		
Rated Current (current setting range) (A)	Current Scale Multiplying Factor Decal No.	Number of Conductor Runs Through Holes	Setting Tap	Type
1 to 2.5	0.25	8	20	SET-3A
2 to 5	0.5	4	20	
4 to 10	1	2	20	
8 to 20	2	1	20	
16 to 40	4	1	40	
32 to 80	8	1	80	
64 to 160	16	1	Fixed	SET-3B

- 7) Connect SEK4 motor protective relay to 6 color coded wires (refer to step 4) extended from 8-pin socket per enclosed print. Make sure the unit is bolted down securely.
- 8) Install motor control box cover, (refer to step 2).
- 9) Referring to wiring diagrams provided change electrical wiring of electric motor by connecting wires 6 and 9 - 5 and 8 - 4 and 7 - 3 to T₃ - 2 to T₂ - and 1 to T₁.
- 10) The unit is now wired for 440-480V and now you may follow our starting directions on the enclosed instruction sheet.
- 11) Reverse procedure for changing to low voltage 220-240V. See instructions provided.

OPERATING & MAINTENANCE INSTRUCTIONS

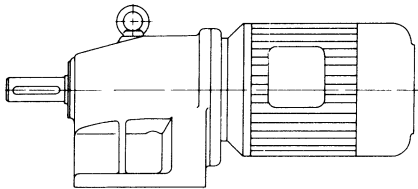

HELICAL

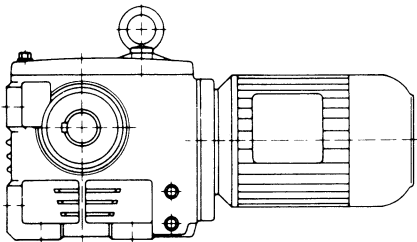

HELICAL-WORM

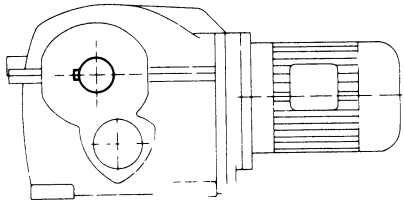

BEVEL-HELICAL

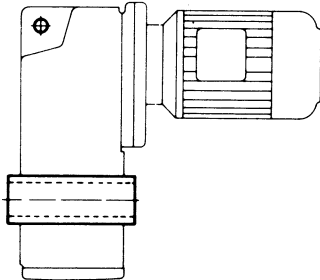

SHAFT MOUNT

NORD Gear Corporation

INSTALLATION

The gearmotor or reducer should be mounted on a structure with enough rigidity to prevent vibration or flexure caused by dynamic loading. The mounting surface should be flat so stresses are not introduced during assembly of the unit on the structure. Externally mounted gears, sprockets and sheaves should be carefully aligned to prevent stresses caused by poorly aligned members.

If a coupling is used it should be a flexible coupling and the halves should be aligned in accordance with the coupling manufacturer's recommendations.

When mounting anything on the shaft of the gear unit the member should be heated if possible to make assembly easier.

Gears, sprockets or sheaves should be mounted as close to the gear housing as possible. Coupling guards should be provided by the customer.

ELECTRICAL CONNECTIONS

Check the motor nameplate to verify the phase, hertz and voltage agrees with the available power supply. Connection should conform to local codes. A connection diagram for the motor is located inside the conduit box and on the motor nameplate. The motor starter should incorporate an overload protector.

START-UP

All units are lubricated before shipment. The breather is plugged for shipment. Before start-up or prolonged storage remove the plastic wick from the breather. The lubricant level should be checked with the unit mounted in it's correct operating position. Lubricant should be added or removed to bring it to the correct level. The catalog for the gear unit shows the oil level for various mounting positions.

MAINTENANCE

A. MOTOR

During maintenance, inspect the fan guard and remove any accumulated debris from under it and around the motor and gear. Motor bearings are greased during assembly. For re-lubrication the following suggestions are offered:

HOURS OF SERVICE PER YEAR	HP RANGE	SUGGESTED RELUBE INTERVAL
5,000	¼ to 7½ 10 to 40 50 to 150	5 years 3 years 1 year
CONTINUOUS Normal Application	¼ to 7½ 10 to 40 50 to 150	2 years 1 year 9 months
SEASONAL SERVICE Motor is idle for 6 months or more	All	1 year (beginning of season)
CONTINUOUS High ambients, dirty or moist locations, high vibrations, or where shaft is hot (pumps—fans).	¼ to 40 50 to 190	6 months 3 months

Use high quality ball bearing grease. Use consistency of grease suitable for class of insulation stamped on nameplate as follows:

INSULATION CLASS	CONSISTENCY	TYPE	TYPICAL	FRAME TYPE
A & B	#2	Lithium Base	Shell Alvania Grease R 3	215 T & smaller
A & B	Medium	Polyurea	Shell Dolium Grease R	254T & larger
F & H	Medium	Polyurea	Shell Dolium Grease R	All

Procedure:

If motor is equipped with Alemite fitting, clean tip of fitting and apply grease gun. Use 1 to 2 full strokes on motors in NEMA 215 frame and smaller. Use 2 to 3 strokes on NEMA 254 through NEMA 365 frame. Use 3 to 4 strokes on NEMA 404 frames and larger. On motors having drain plugs, remove grease drain plug and operate motor for 20 minutes before replacing drain plug.

On motors equipped with slotted head grease screw, remove screw and apply grease tube to hole. Insert 3 to 3 inch length of grease string into each hole on motors in NEMA 215 frame and smaller. Insert 3 to 5 inch length on larger motors. Motors having grease drain plugs, remove plug and operate motor 20 minutes before replacing drain plug.

Caution: Keep grease clean. Lubricate motors at standstill. Remove and replace drain plugs at standstill. Do not mix petroleum grease and silicone grease in motor bearings.

B. GEARS

Gear units should have the oil changed every 10,000 hours or 2 years. If synthetic lubricant is used it should be changed every 20,000 hours or 4 years. For adverse operating conditions the interval should be shorter. DO NOT MIX SYNTHETIC & MINERAL BASE OILS. Units should be checked periodically for increased noise, surface temperature, vibration, shaft movement & amperage draw. Units with inspection covers should not be operated with the inspection cover removed.

The table below offers suggestions on the viscosity & manufacturers of recommended lubricants.

VISCOSITY RANGE FOR AGMA LUBRICANTS

RUST AND OXIDATION INHIBITED GEAR OILS	VISCOSITY RANGE ‡	EQUIVALENT ISO GRADE ◀	EXTREME PRESSURE GEAR LUBRICANTS ‡‡	VISCOSITIES OF FORMER AGMA SYSTEM ◀◀
AGMA Lubricant No.	mm ² /s (cSt) at 40 °C		AGMA Lubricant No.	SSU at 100 °F
1	41.4 to 50.6	46		193 to 235
2	61.2 to 74.8	68	2 EP	284 to 347
3	90 to 110	100	3 EP	417 to 510
4	135 to 165	150	4 EP	626 to 765
5	198 to 242	220	5 EP	918 to 1122
6	288 to 352	320	6 EP	1335 to 1632
7 Comp	414 to 506	460	7 EP	1919 to 2346
8 Comp	612 to 748	680	8 EP	2837 to 3467
8A Comp	900 to 1100	1000	8A EP	4171 to 5098

NOTE: Viscosity ranges for AGMA lubricant numbers will henceforth be identical to those of ASTM 2422.

‡ “Viscosity System for Industrial Fluid Lubricants”, ASTM 2422. Also British Standards Institute, B.S. 4231.

◀ “Industrial Liquid Lubricants—ISO Viscosity Classification.” International Standard, ISO 3448.

‡‡ AGMA 250.03, May, 1972 and AGMA 251.02, November, 1974.

◀◀ Oils marked Comp are compounded with 3% to 10% fatty or synthetic fatty oils.

RECOMMENDED LUBRICANTS FOR HELICAL & BEVEL-HELICAL GEARING

Type of Lubricant	Ambient Temperature Range (°F)	kin Viscosity (cSt) at 40°C (mm 2/S)	Viscosity SUS 175 100°F	AGMA Lubricant No.	ISO Grade	AMOCO	CHEVRON	EXXON	MOBIL	SHELL	TEXACO
Oil	15 to 125	198 to 242	900 to 1100	5EP	220EP	AMOGEAR EP220	NL GEAR Compound 220	SPARTAN EP220	Mobil Gear 630	Omala Oil 220	Meropa 220
	-10 to +75°	90 to 765	465 to 165	3-4EP	100-150EP	AMOGEAR EP150	NL GEAR Compound 150	SPARTAN EP 150	Mobil 629	Omala Oil 100	Meropa 150
	Below 10° ‡‡	15 to 680	135 to 165	—	—	—	E.P. Hydraulic Oil 22	UNIVIS J13	Mobil D.T.E. 11	—	Texamatic Fluid 9226 or Texamatic Type F
Oil—Synthetic	-40° to 175° ‡‡	—	90 to 4000	—	—	—	—	—	Mobil SHC 629 or 634	—	Synstar GL75W-140
Fluid Grease	5° to 120°	—	—	—	—	—	—	—	—	—	MARKFAK 00

For bearings not lubricated in oil bath use a lithium base bearing grease, NLGI #2 or #3

‡ Ambient temperatures below -20°F and above 140°F require special oil seals

‡‡ Consult with Nord Gear Corporation for these applications

Bold ambient temperature indicates factory filled

Actual capacity should be established by opening the oil level plug and filling until oil runs out of the oil level hole.

RECOMMENDED LUBRICANTS FOR HELICAL-WORM GEARING

TYPE OF LUBRICANT	AMBIENT TEMP RANGE °F	KIN VISCOSITY (cSt) AT 40°C (mm 2/S)	VISCOSITY SUS 175 100°F	ISO GRADE	MOBIL	TEXACO
Oil Synthetic	-40° to 175° ‡	198 to 352	900 to 1600	220	Glygoyle 30	Synstar GL75W 140

For bearings not lubricated in oil bath use a lithium base bearing grease, NLGI #2 or #3

‡ Ambient temperatures below 0°F and above 100°F require special oil seals

Consult NORD GEAR CORPORATION for these applications

STORAGE

Units shipped from Nord are intended to be used within 30 days after receipt and presumed to be stored indoors in a heated building. If you intend storing units under adverse conditions or for a long period of time special storage precautions will be necessary.

1. Store in a sheltered area away from chemical vapors or steam.
2. Cover.
3. Do not store in sunlight or near high heat.
4. Remove plastic wick from breather.
5. Spray oil on exposed shafts & seals. Remove oil on start-up.
6. Rotate output shaft 360° every 3-4 weeks.

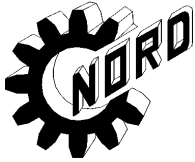

TITAN™ Adjustable Speed Drives Installation and Maintenance Instructions

BIM-4010/2004

USA

CDN

Retain These Safety Instructions For Future Use



In-Line Helical



Parallel Shaft Helical (Clincher™)



Helical-Bevel (3-Stage)

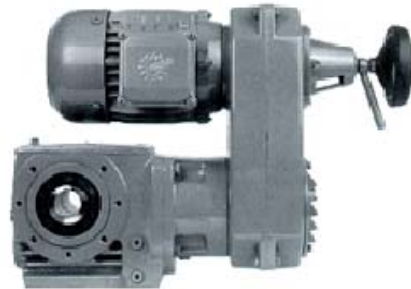

Helical-Worm

INSPECTION OF UNIT

Thoroughly inspect the equipment for any shipping and handling damage before accepting shipment from the freight company. If any of the goods called for in the bill of lading or express receipt are damaged or the quantity is short, do not accept until the freight or express agent makes an appropriate notation on your freight bill or express receipt. If any concealed loss or damage is discovered later, notify your freight carrier or express agent at once and request him to make an inspection. We will be very happy to assist you in collecting claims for loss or damage during shipment; however, this willingness on our part does not remove the transportation company's responsibility in reimbursing you for collection of claims or replacement of material. Claims for loss or damage in shipment must not be deducted from the NORD Gear invoice, nor should payment of the NORD Gear invoice be withheld awaiting adjustment of such claims, as the carrier guarantees safe delivery.

If considerable damage has been incurred and the situation is urgent, contact the nearest NORD Gear Sales Office for assistance. Please keep a written record of all communications.

RECORD NAMEPLATE DATA

Locate the gear reducer nameplate and record all nameplate data for future reference.

SK _____ S/N _____

RATIO _____ MAX TORQUE _____ RPM _____ MTG. POS. _____

GENERAL INFORMATION

The following operating and maintenance instructions are intended to help with general installation and maintenance procedures.

It is presumed that system design, as well as all work with regard to transport, assembly, installation, starting-up, maintenance and repair, is performed by qualified personnel or supervised by skilled labor taking overall responsibility.



WARNING:

LOCK OUT POWER before any maintenance is performed. Make absolutely sure that no voltage is applied while work is being done on the drive.

BASIC OPERATION AND SPEED ADJUSTMENT

Titan™ Adjustable-Speed Drives are ideal for use when operating conditions dictate infinitely variable output speeds over a fixed range. The Titan™ Drive consists of a motor, belt casing, and main gear drive.

The beltbox contains an Adjusting Pulley (Driver) that is attached to the motor output shaft. A handwheel (or optional Electric Remote Control) is used to vary the operating pitch diameters of the driver pulley in-turn making a corresponding adjustment to the Spring Pulley (Driven). Belt center distance remains fixed. Speed is typically adjusted by loosening the lock nut handle on the handwheel.



WARNING:

Speed adjustments must be performed when the motor is operational. Failure to comply may damage the belt and pulleys.



WARNING:

Initial adjustment of the speed stops located internal to the beltbox are completed at the factory. Further adjustments of the speed stops can cause damage to the beltbox and/or main drive.

INSTALLATION

Titan™ drive packages may be supplied with a variety of gear units including foot-mounted, flange-mounted or shaft-mounted options. *Complete drive packages may also be assembled in the "U"-Flow or "Z"-Flow patterns as shown on Page 4.*

When selecting the drive installation site, one should remember that air-cooled motors are ideally designed for ambient temperatures between -4°F and +104°F (-20°C and +40°C) and for installation at altitudes of 3,300ft (1,000m) above mean sea level.

The installation site should also ensure the following:

- Unrestricted airflow over the motor and variable speed drive.

- Accessibility to the oil fill-hole, level-hole and vent-hole locations on the main gear drive.
- A foundation (mounting base) of adequate size that is flat, torsionally rigid, and vibration-proof.
- Adequate shaft alignment between the drive and the driven equipment.
- Adequate space to allow motor removal and/or maintenance.
- In cases where brake motors are used, fan guard removal may be necessary to allow for brake adjustment and maintenance.

MOTOR

Please reference the manufacturers Installation and Maintenance Manual/s to obtain detailed instructions pertaining to the motor or brakemotor.

Connect the motor in accordance with the wiring diagram information supplied with the motor. Be sure the voltage supplied to the motor is accordance with the rated voltage on the nameplate. A protective motor switch is recommended to help protect the motor windings from overload and/or phase failure.

To insure the same performance the replacement motor must be of the same design and style as the original. The end of the motor shaft must also have a tapped hole in it as shown below.

NEMA FRAME SIZE	THREAD SIZE	MINIMUM THREAD DEPTH
56C	1/4-20	1.00 inch
143TC/145TC	1/4-20	1.00 inch
182TC/184TC	3/8-16	1.25 inch
213TC/215TC	5/8-11	1.25 inch
254TC/256TC	5/8-11	1.50 inch
284TC	5/8-11	1.50 inch

GEAR REDUCER

For the main gear drive, please reference the appropriate Installation and Maintenance manual, as shown below:

Number	Description
IM-1010	UNICASE™ Helical Inline Drives
IM-1020	CLINCHER™ Parallel Shaft Helical Drives
IM-1040	Helical-Bevel Drives (3-Stage, "90XX-Series")
IM-1030	Helical-Worm Drives

TITAN™ BELT CASING

Pulleys are manufactured from the corrosive resistant and extremely durable alloy "Durfondal" to provide superior wear resistance and assure grooving and wear will be minimized under rated operating conditions. Pulleys are permanently grease lubricated and should require no disassembly during the normal life of the Titan™ drive. All sliding components are coated to resist fretting and corrosion.

When operating in extremely dusty or dirt environments, an air filter must be installed to the main housing vents to protect the V-belt, pulleys, and coated shafts.

When operating in areas of higher ambient temperatures, or when installed where ventilation is poor, additional cooling may need to be applied to the belt housing.

The adjustment wheel spindle (511) must occasionally be cleaned and lubricated to assure trouble-free operation. Detailed instructions concerning belt removal and pulley removal will be covered in later sections of this manual.

V-Belt Replacement

Please reference the General Parts List shown on Page 8 of this manual.

1. Run the Titan™ drive to its maximum speed and switch off. Be certain the power can not be inadvertently switched on again.
2. Unscrew the socket head screws (521) and remove the belt casing cover, together with the entire speed control unit.
3. Remove the old V-belt by first drawing it over the cones of the spring-loaded pulley (507) and then sliding over the open adjustable pulley (506). Installing a tapered wedge made of soft pine between the spring pulley halves will help keep the adjustable pulley open, and may aid in the removal of the old V-belt.
4. Wrap the new V-belt around the cones of the open adjustable pulley (506) and then draw it over the spring-loaded pulley (507). Installing a tapered wedge made of soft pine between the spring pulley halves will help keep the adjustable pulley open, and may aid in the installation of the new V-belt.
5. Reassemble the belt casing cover.



WARNING

Nord does not support the use of the Titan™ belt drive in explosion proof or hazardous environments. Although the belt is non-sparking, the belt drive does not have a safety to disengage the belt. Should an overload occur and the belt begin to slip, excessive heat could be generated.

Pulley Replacement

Please reference the diagrams shown below, as well as the General Parts List shown on Page 8 of this manual.

1. The spring loaded pulley (507) and the adjustable pulley (506) are held securely to the shaft using a holding screw (519/516), a thrust washer (518/515), and a snap ring (520/517). Remove the screw (519/516), thrust washer (518/515) and snap ring (520/517) that are used to hold the pulley on the shaft.
2. In order to protect the tapped hole in the shaft, place a steel disc (I), slightly smaller than the shaft diameter, against the end of the shaft.
3. The thrust washer has an internal thread diameter that is slightly larger than the thread on the holding screw (516/519). Refit the snap ring (520/517) and replace the thrust washer (518/515). In order to aid in the removal of the pulley, a disassembly screw, slightly larger than the holding screw (516/519) can be inserted into the thrust washer (518/515) and tightened against the steel disc (I). Remove the spring loaded pulley (507) or the adjustable pulley (506) by using the thrust washer and disassembly screw (III) as a "jacking bolt".
4. If the thrust washer (518/515) rotates when trying to remove the pulley, secure the thrust washer with a pin inserted into the keyway (II).
5. After the old pulley is removed, disassemble or remove the disassembly screw (III), thrust washer (518/515), snap ring (520/517), and protective steel disc (I) that was placed over the shaft.
6. Before installing the new pulley, apply an anti-seize compound to the shaft. Reassemble the snap ring (520/517) and thrust washer (518/515) into the pulley bore. Use the holding screw (519/516), pull the pulley onto the shaft. Do not drive the pulley onto the shaft with a hammer.

Spring Loaded Pulley Shown Below

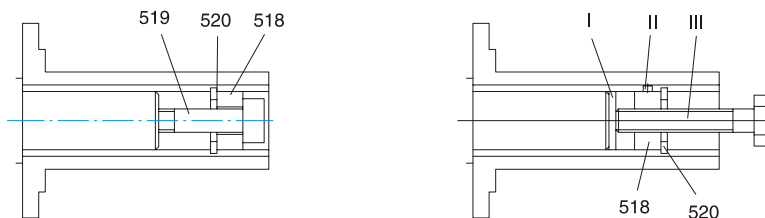

WARNING:

When installing new pulleys, care must be taken to ensure they are installed in the same exact orientation as the old pulleys. Assembly of the pulley the wrong way can result in damage to the machinery. Special care must be taken when reassembling the Z-Flow pattern, as the moving parts of the pulleys must always be situated on opposite (diagonal) sides.



WARNING:

Do not attempt to disassemble spring pulley. Failure to remove the spring without the proper fixtures/tools can result in serious injury.

U-FLOW

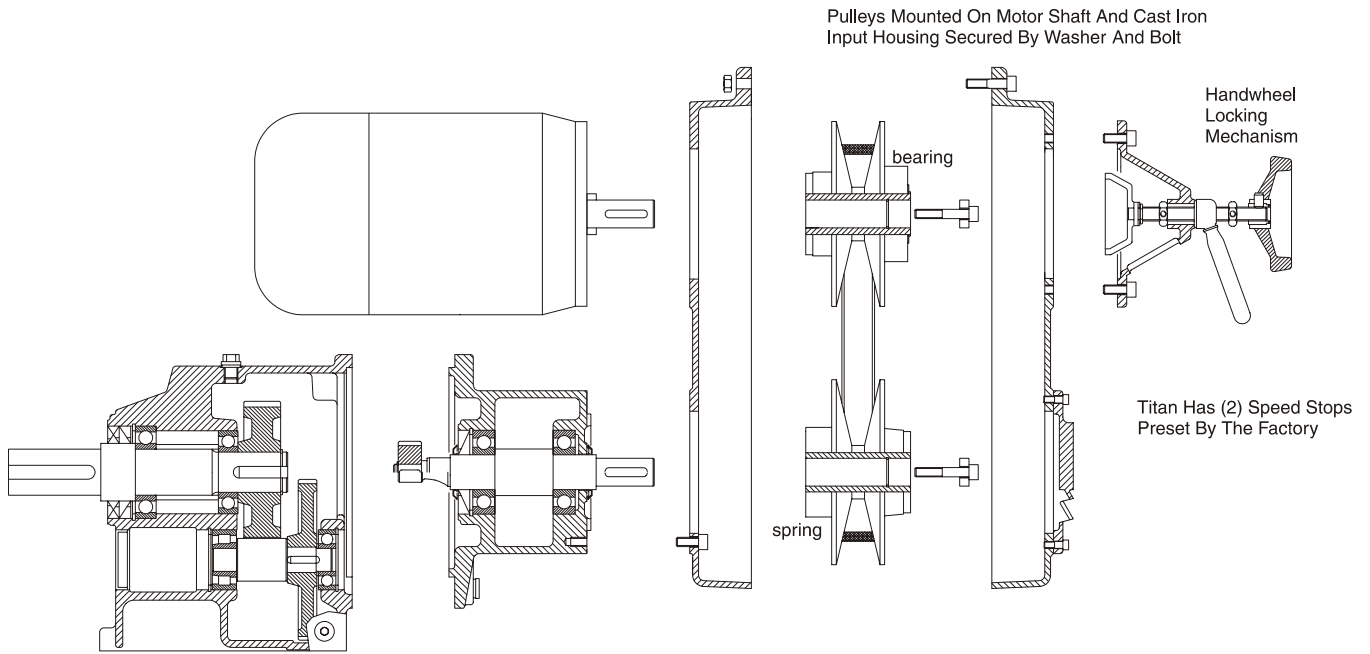

Gear Reducer Can Be:

- * Unicase - Inline Helical
- * Unicase - Clincher Helical
- * Unicase - Helical Worm
- * Unicase - Helical - Bevel

- * No Bearings Mounted In Housing
- * Corroduty Alloy

Z-FLOW

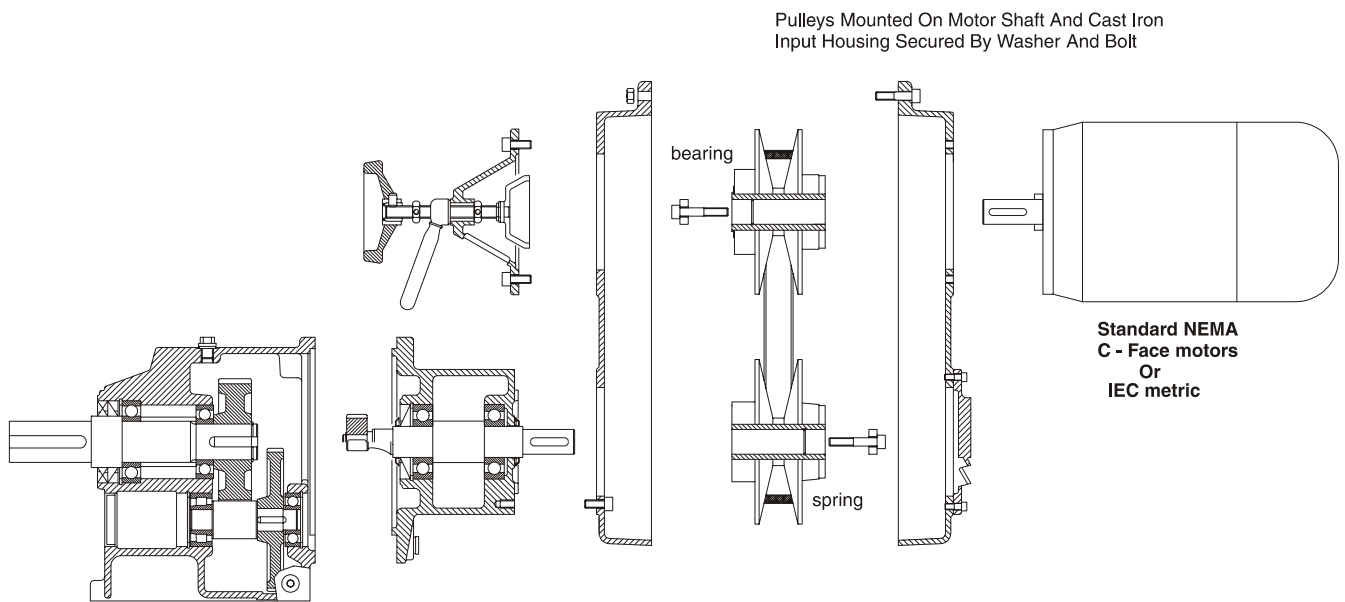

Gear Reducer Can Be:

- * Unicase - Inline Helical
- * Unicase - Clincher Helical
- * Unicase - Helical Worm
- * Unicase - Helical - Bevel

- * No Bearings Mounted In Housing
- * Corroduty Alloy

ADJUSTING SPEED WITH OPTIONAL ELECTROMECHANICAL REMOTE CONTROL (ERC)

The Electromechanical Remote Control (ERC) replaces the hand wheel when remote speed adjustment is desired. The typical ERC is a worm-gearmotor with limit switches and potentiometer located under the cover of the speed control gearmotor. The limit switches are used to prevent the ERC motor from rotating the spindle adjustment all the way against the mechanical speed stops located inside the friction drive. The friction drive leaves the factory set to the speed range indicated on the nameplate.

NOTE: NORD Gear does not supply the motor starter, overload protection, or push buttons.

DIAGRAM FOR THREE PHASE ERC MOTOR

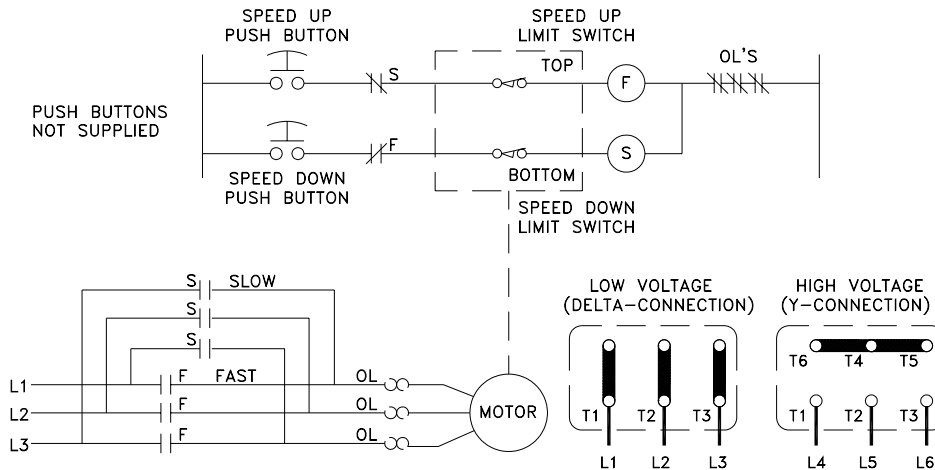
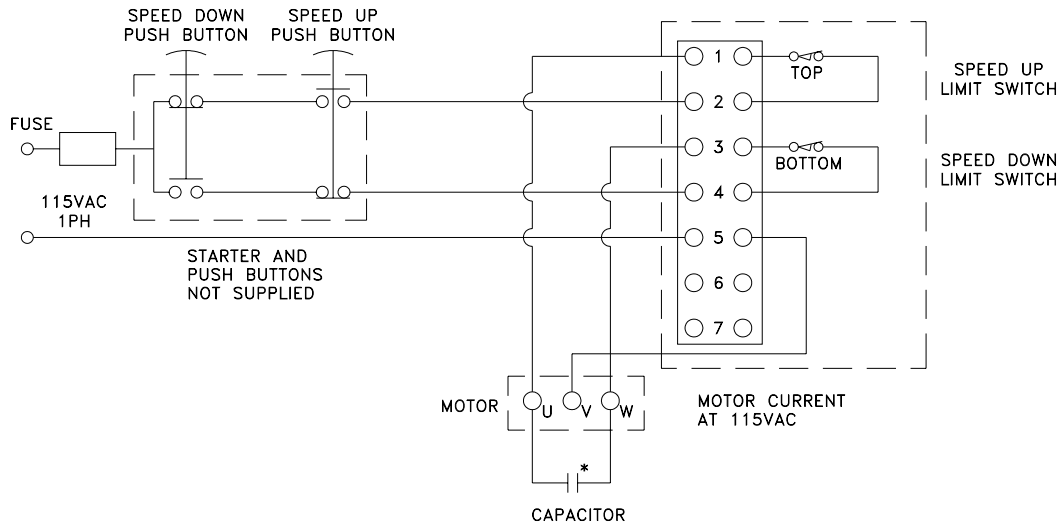

DIAGRAM FOR SINGLE PHASE ERC MOTOR



Electromechanical Remote Control (ERC)			
	Three Phase Operation		Single Phase Operation
ERC Part Number	28090100	28090100	28090110
Operating Frequency	60 Hz	50 Hz	60 Hz
Power Rating	70 W	70 W	70 W
Input Speed	1650 RPM	1375	1650 RPM
Supply Voltage	230 Δ / 460 Y Volts	230 Δ / 400 Y Volts	110-115 Volts
Current	0.44-0.25 Amps	0.51-0.29 Amps	1.15 Amps
Enclosure	TENV	TENV	TENV
Output Speed	30 RPM	25 RPM	30 RPM
Limit Switch	15A, 250 V	15 A, 250 V	15A, 250 V
Potentiometer	22 kΩ linear turning range: 270° loading capacity: 0.15 W	22 kΩ linear turning range: 270° loading capacity: 0.15 W	22 kΩ linear turning range: 270° loading capacity: 0.15 W

Limit Switch / CAM Adjustment

1. Remove cover from the speed control unit.
2. Loosen the locking screw on the CAM of the upper end limit switch.
3. Run the motor to the maximum drive output speed.
4. Rotate the CAM of the upper end limit switch clockwise, until the cam trips the limit switch. Re-tighten the locking screw.
5. Loosen the locking screw on the CAM of the lower end limit switch.
6. Run the motor to the minimum drive output speed.
7. Rotate the CAM of the lower end limit switch counter-clockwise, until the cam trips the limit switch. Re-tighten the locking screw.
8. Re-install the cover onto the speed control unit.

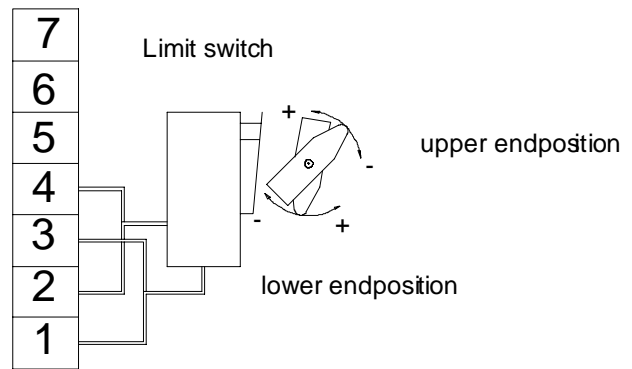

WARNING:

When adjusting the speed control range take care to make sure the speeds indicated on the nameplate are not exceeded or under run.

Potentiometer Adjustment

Like the limit switches, the potentiometer is factory preset. The potentiometer is coupled to the limit switches.

1. Turn the potentiometer counter-clockwise until it runs against the stop (Variable speed unit must be set to minimum speed).
2. Loosen the coupling set screws.
3. Turn the potentiometer approximately 15° clockwise.
4. Between Terminals 6 and 7 there must be a resistance of 120 Ω.
5. Tighten the coupling set screws.

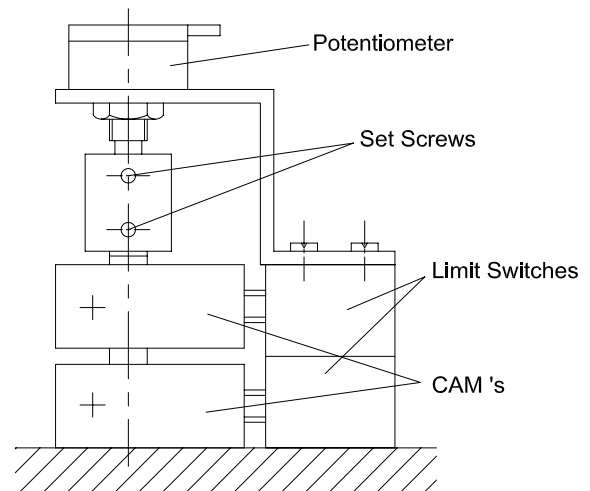

Non Contacting Speed Indicator

Type BLA – with analog indicator
Type BLD – with digital indicator

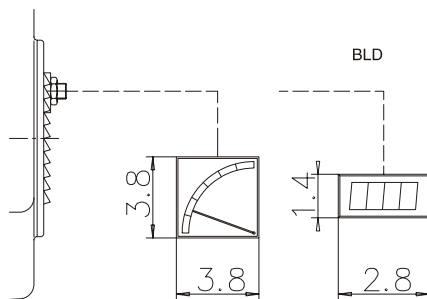

Type BLA:

The speed indicator contains a built in sensor which converts the signals coming from the pulse generator into a direct current which is connected to the analog indicator. Adjustment of the meter is possible by means of set screws on the back of the meter.

Type of enclosure: IP 53 – Terminals IP 00
Scale Marking: 0-100% - Scale deflection: 90°

Type BLD:

The digital indicator has a 4 digit – 7 segment red LED display.
Type of enclosure: IP 50 – Terminals IP 00.

Electro-Mechanical Remote Control EMFST with Remote Speed Indicator

Type FAA – with analog indicator
Type FAD – with digital indicator

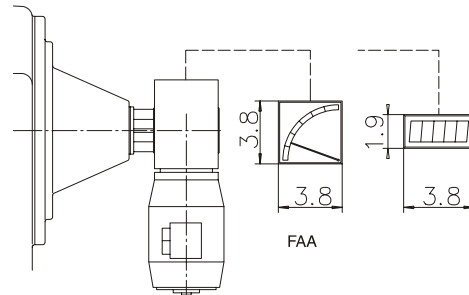

Type FAA:

In addition to the electro-mechanical remote control the remote speed indicator is available, showing the speed setting in percent.

Type of enclosure: IP 21 – Terminals IP 00
Marking of Scale: 0-100%
Scale deflection: 90°

Type FAD:

The digital indicator has a 4 1/2 digit – 7 segment red LED display, Type of enclosure: Casing IP 20, Terminals IP 00.

NOTES

General Parts Lists

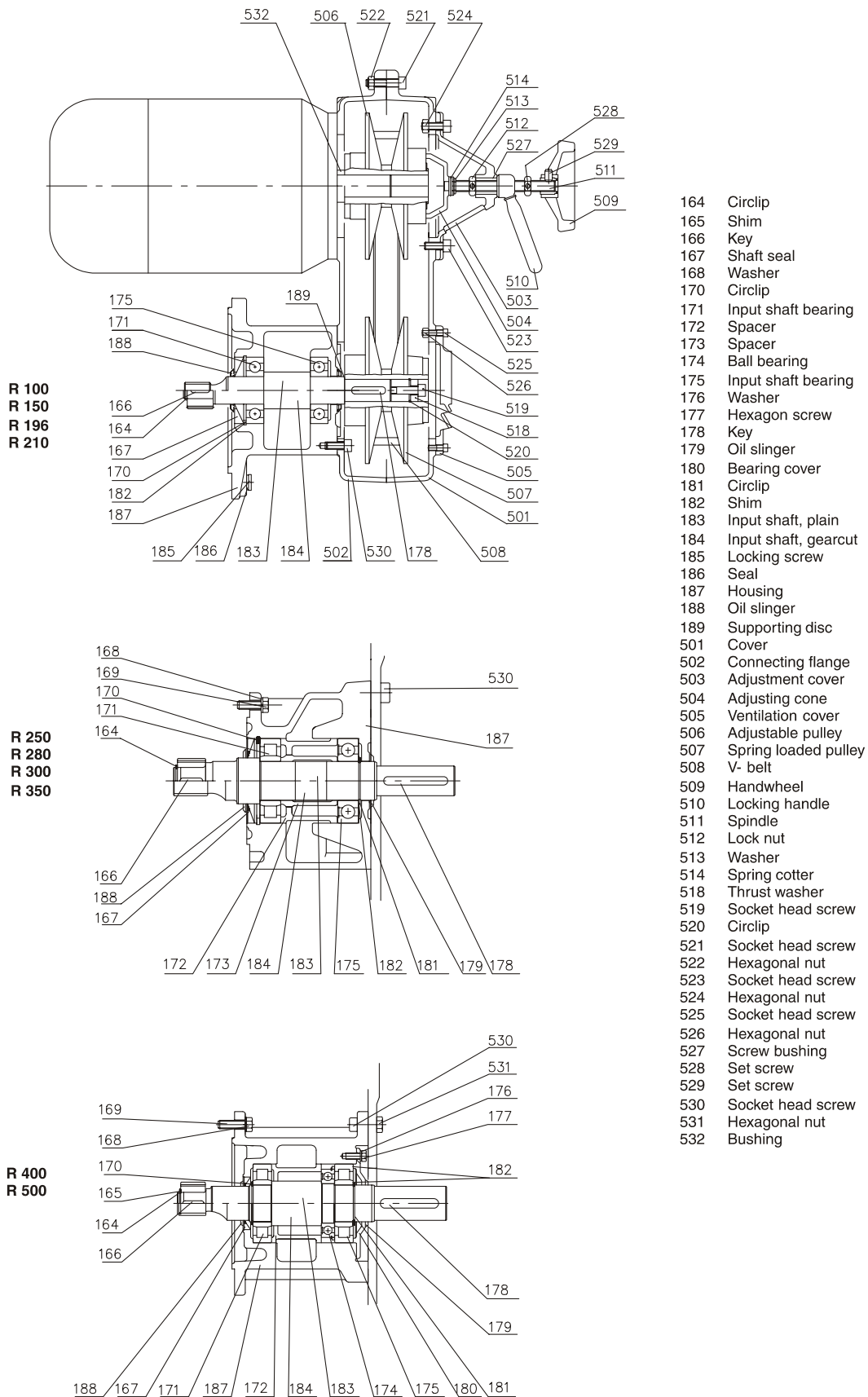

General Parts List

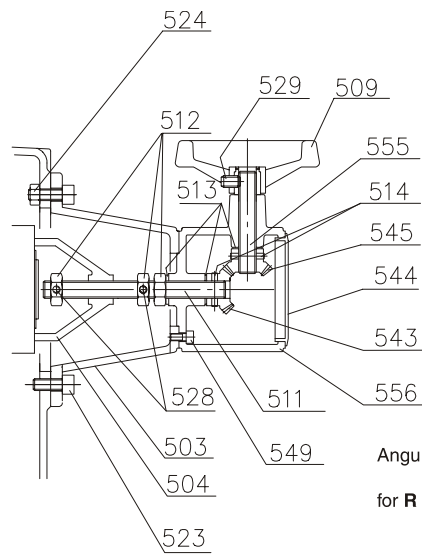

Angular control type **WST**
for **R 100 - R 400**

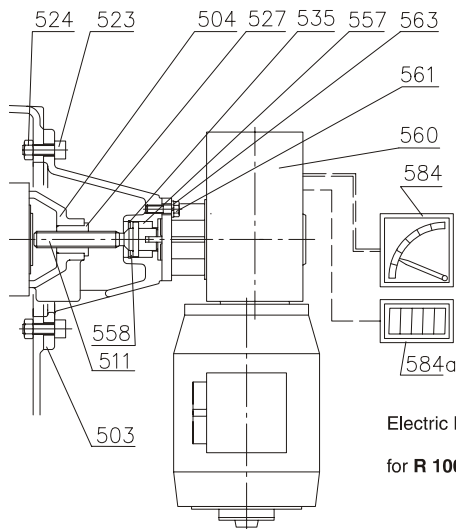

Electric Remote Control type **EMFST**
for **R 100 - R 350**

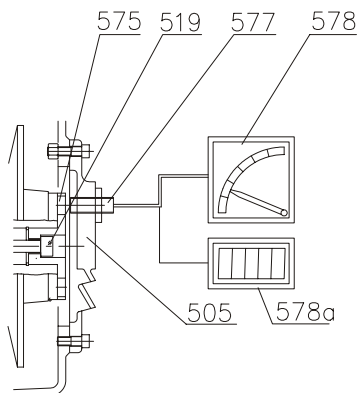

Non-contacting speed indicator
for **R 100 - R 500**

- 503 Adjustment cover
- 504 Adjusting cone
- 505 Ventilation cover
- 509 Handwheel
- 511 Spindle
- 512 Lock nut
- 514 Spiral pin
- 519 Socket head bolt
- 523 Socket head bolt
- 524 Hexagonal nut
- 527 Tapped bushing
- 528 Set screw
- 529 Set screw
- 535 Circlip
- 543 Bevel Gear
- 544 Sealing plug
- 545 Bevel Gear
- 549 Socket head bolt
- 555 Shaft
- 556 Case
- 557 Bushing
- 558 Washer
- 560 Worm geared motor
- 561 Hexagon bolt
- 563 Washer
- 575 Pulse generator
- 577 Pulse sensor
- 578 Speed indicator
- 584 Teleindicator

TITAN™ V-BELT PART NUMBERS AND SIZES

TYPE	R100	R150	R196	R210	R250	R280
Belt P/N	7109200	71592000	71992000	72192000	72592000	72892100
Belt Size	22 x 7 x 567 x 28°	28 x 8 x 754 x 28°	33 x 9 x 906 x 28°	37 x 10 x 954 x 28°	47 x 12 x 1135 x 28°	55 x 15 x 1255 x 28°
TYPE	R300	R350	R375	R400	R500	
Belt P/N	73092100	73592100	73792100	74092100	75092100	<i>(Dimensions = mm)</i>
Belt Size	51 x 16 x 1444 x 28°	70 x 18 x 1515 x 30°	83 x 23 x 1767 x 32°	83 x 23 x 1842 x 32°	83 x 26 x 2877 x 32°	

TROUBLESHOOTING

PROBLEM WITH VARIABLE SPEED UNIT	POSSIBLE CAUSES	SUGGESTED REMEDY
Drive Slips	V-Belt is worn.	Replace V-Belt (Page 3).
	V-Belt or face of adjustment pulley is dirty or contaminated.	Clean Contaminated part: <ul style="list-style-type: none"> V-Belt – use dry cloth or paper. Adjustment Pulley – okay to use mild solvent provide excess is cleaned with a dry cloth.
	Load is too high.	Check measured power and reduce operating load to catalog values.
Drive heats up excessively	Load is too high.	Check measured power and reduce operating load to catalog values.
Drive appears noisy or too loud.	V-Belt is damaged: <ul style="list-style-type: none"> May be caused after a brief stalling of the drive. May be caused by intermittent loading of the drive. 	Determine cause of damage, and replace V-Belt.

PROBLEM WITH ELECTROMECHANICAL REMOTE CONTROL	POSSIBLE CAUSES	SUGGESTED REMEDY
Speed cannot be adjusted.	Unit is not wired properly	Wire unit in accordance with circuit diagram (Page 5).
Speed range cannot be reached.	Limit switches of ERC motor switch off too early.	Adjust limit switch CAM's (Page 6).
Adjust rate is too low.	Sluggish adjustment rate may be due to corrosion between the slide plate and the cam grooves that are internal to the intermediate housing.	Re-establish low-friction conduction. <ul style="list-style-type: none"> Separate driven disc assembly from driving disc assembly. Clean and re-lubricate slide plate and cam grooves by applying a molybdenum-based anti-seize compound to these surfaces. In some instances it may be necessary to remove the motor and cam grooves in order to thoroughly clean the cam grooves and slide plate. In these instances the cam grooves may need to be re-adjusted (Page 4)

NORD Gear Corporation

National Customer Service Toll Free 888-314-6673

www.nord.com

NORD Gear Limited

Toll Free in Canada 800-668-4378

WEST

1121 Railroad Street
Building 101
Corona, CA 92882
Phone 909-279-2600
Fax 888-408-6673

MIDWEST

PO Box 367
800 Nord Drive
Wauwaukee, WI 53597
Phone 608-849-7300
Fax 800-373-6673

SOUTH

100 Forsyth Hall Dr.
Building 100B
Charlotte, NC 28273
Phone 704-529-1255
Fax 888-259-6673

CANADA

41 West Drive
Brampton, Ontario L6T 4A1
Phone 905-796-3606
Fax 905-796-8130



BIM 1004

USA

CDN

MOTORS

AC Induction, Single and Polyphase

Installation and Maintenance Instructions

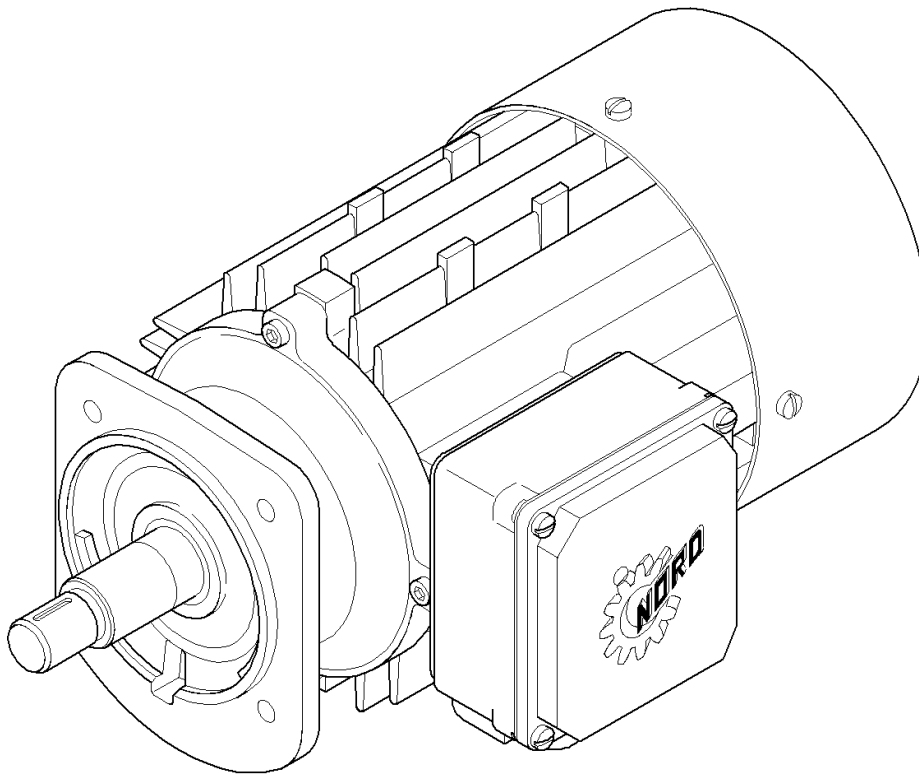

Copyright © 2005, NORD Gear Corporation

All rights reserved. No part of this book covered by the copyright hereon may be reproduced or copied in any form or by any means without the written permission of the NORD Gear Corporation.

NOTES

TABLE OF CONTENTS

<u>Subject</u>	<u>Page</u>
Introduction.....	4
Description and Operation	4
Inspection.....	6
Testing and Fault Isolation.....	7
Lubrication.....	9
Removal, Installation, and Handling.....	9
Connection Diagrams.....	12
Repair.....	13
Parts List	14
Motor Options & Nomenclature	17

LIST OF ILLUSTRATIONS

<u>Figure No.</u>	<u>Figure Title</u>	<u>Page</u>
Figure 1	Motor Nameplates.....	5
Figure 2	Motor & Options Connection Diagrams.....	12
Figure 3	General Motor Exploded View and Generic Parts List (2 pages).....	15

LIST OF TABLES

<u>Table No.</u>	<u>Table Title</u>	<u>Page</u>
Table 1	Related Publications	4
Table 2	Nameplate Data.....	5
Table 3	Motor Inspection Criteria.....	6
Table 4	Motor Fault Isolation	8
Table 5	Motor Option Codes & Nomenclature.....	17
Table 6	Space Heater Data.....	19
Table 7	Encoder Wiring Designations.....	19
Table 8	Blower Cooling Fan Data	20

INTRODUCTION

1. General

This manual includes general motor description and operation, inspection, testing and fault isolation procedures and information, general lubrication instructions and materials, general installation, removal, and handling instructions, and general repair and parts information.

2. Related Publications

The related publications listed in Table 1 provide additional information to support maintenance and fault isolation of the motor and its installation.

Publication Number	Publication Title
BIM 1001	Hollow Shrink Disc Shaft
BIM 1002	Hollow Keyed Shaft and Fixing Element
BIM 1003	Expansion Chambers
BIM 1004	Motors AC Induction, Single Phase and Polyphase
BIM 1009	NORD Gearbox Inputs (Motor Adapters and Couplings)
BIM 1010	UNICASE [®] Helical Gearboxes
BIM 1011	NORDBLOC [®] Helical Gearboxes
BIM 1012	Standard Helical Inline Gearboxes
BIM 1020	UNICASE [®] Shaft Mount Gearboxes
BIM 1030	UNICASE [®] Helical Worm Gearboxes
BIM 1031	MINICASE [®] Worm Gearboxes
BIM 1033	SI Design UNIBLOC [®] Worm Gearboxes
BIM 1040	UNICASE [®] 90.1 Helical Bevel Gearboxes
BIM 1090	Motor Brakes
BIM 1142	NORDBLOC [®] 92 Series Helical Bevel Gearboxes
BIM 4010	Titan Mechanical Adjustable Speed Drives
BIM 4020	NORDISC [®] Friction Disc Mechanical Adjustable Speed Drives

Table 1. Related Publications

DESCRIPTION AND OPERATION

1. General

This manual provides general installation and maintenance information for the NORD family of motors described in this section.

2. Description

The NORD motors covered in this manual are single phase and poly-phase motors (refer to Table 2), can be single speed or two-speed, and may include the options listed in the Motor Options Section. Motor options, electrical requirements, performance characteristics, and motor data are identified on the motor nameplate. The nameplate drawing is provided in Figure 1. Definition of each entry field is provided in Table 2.

3. Operation

The motors described in this manual are alternating current (AC) induction motors, single speed or two-speed, and convection-cooled, fan cooled, or blower cooled. The motors may use single phase or three phase alternating current.

Cooling options include convection cooling (TENV), fan cooling (TEFC), and blower cooling (TEFB). Because the fan is mounted on the motor shaft, the fan speed is identical to the motor speed, and the cooling capacity varies with the motor speed. The blower uses its own motor and a separate power supply to provide a specific airflow and cooling capacity. The blower power data are provided in Table 8.

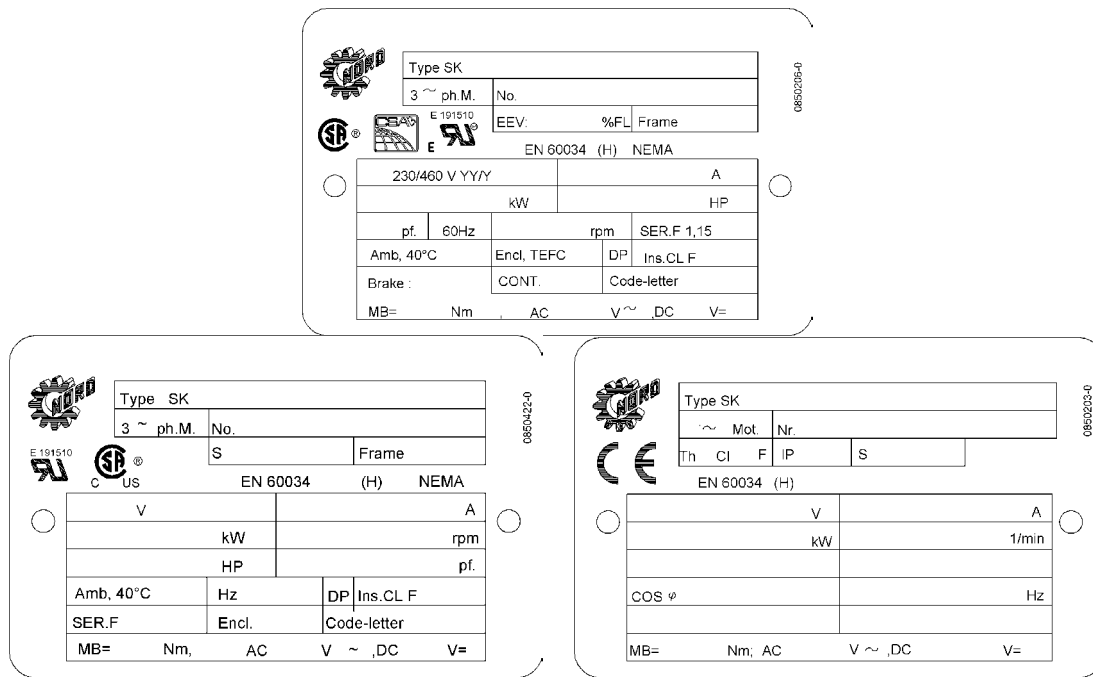

Figure 1. Motor Nameplates

Field	Definition	Field	Definition
Type	Model Number	DP	Drip Proof
3~ph.M.	Number of Motor Phases	Ins. Cl	Insulation Class
No.	Motor Number	SER. F	Service Factor (allowable horsepower loading)
S	Duty Cycle (i.e. S1, S3-40%)	Encl.	Enclosure Description
Frame	Motor Frame Size	Code	NEMA Code Letter
V	Motor Voltage	EEV	
A	Motor Full-Load Amperage	COS φ	Power Factor
HP	Motor Horsepower	MB=	Motor Brake Force (Newton Meters)
rpm	Motor Speed	AC	Alternating Current
pf.	Power Factor	V~	AC Voltage
Amb	Maximum Ambient Temperature	V=	DC Voltage
Hz	Motor Power Frequency		

Table 2. Nameplate Data

INSPECTION

1. Inspection Interval
Inspect the motor after every 500 operating hours.
2. Inspection Criteria
Inspect the motor according to the criteria in Table 3.

CAUTION: IF IT IS NECESSARY TO CLEAN THE MOTOR EXTERIOR, DO NOT USE SHOP AIR. SHOP AIR CAN FORCE CONTAMINANTS INTO THE MOTOR, AND CAN CAUSE THE BLOWN CONTAMINANTS TO AFFECT OTHER COMPONENTS.

Inspect	Check	Action
Motor exterior	Check the external surfaces for contamination. Accumulation of dirt and fibrous deposits must be removed.	Clean the motor external surfaces using clean, lint-free cloths. Clean deposits from between cooling fins using a vacuum cleaner and a stiff-bristled nylon brush.
	Check the external surfaces for oil film and greasy deposits.	Clean the oil film and greasy deposits from the motor surface using clean, lint-free cloths. If necessary, moisten the cloth with an approved non-flammable, residue-free solvent. Do not pour solvent on the motor.
	Check for evidence of damage or overheating.	If the motor has physical damage, replace the motor.
Motor mountings	Make sure the mounting hardware is secure.	If the mounting hardware is not secure, check the motor/gearbox alignment, and tighten the mounting hardware.
Motor electrical connections	Check that all electrical connections are secure.	If the electrical connections are not secure, tighten them.
	Check the electrical connections for evidence of arcing.	Loose electrical connections can cause arcing, which is evident by discoloration and charring. If you find evidence of arcing, replace the damaged connections.
Insulation resistance	Using an ohmmeter, check and record the resistance of motor winding insulation.	Compare the current resistance reading to previous readings. If the resistance drops significantly, perform an internal inspection for insulation damage or deterioration.
Motor Brake	On motors that have a brake, use a feeler gauge to check the air gap in between the brake pad and the rotor according to NORD Gear Corporation Manual BIM-1090, Motor Brakes Installation and Maintenance Instructions.	If the air gap exceeds the maximum allowed for that brake configuration provided in the manual, adjust the air gap or replace the brake pad according to the instructions in NORD Gear Corporation Manual BIM-1090, Motor Brakes Installation and Maintenance Manual.

Table 3. Motor Inspection Criteria

TESTING AND FAULT ISOLATION

1. General

NOTE: NORD electric motors do not require periodic testing. However, if a motor is removed from its installation, NORD recommends that the motor be checked according to the static and dynamic testing provided below before it is reinstalled. Finding a condition that will require future repair before the motor is reinstalled decreases the overall maintenance time.

This section provides general test information and functional checks for the types of motors covered by this manual. All tests provided below may not apply to all motor types and models. Read and understand the tests and checks before performing them on your motor. Understand how the test or check is to be performed and the pass/fail criteria.

Record and date all measurements taken. Retain the measurements in a file. Comparing current and previous measurements is useful in tracking motor condition and brake wear, if the motor is equipped with a brake.

If the motor fails any of the test procedures provided below, use the fault isolation procedures to determine the motor problem. Refer to the REPAIR section to determine if the failure is a repairable failure.

2. Testing

A. Static Testing

1. The motor can only be static tested if it is disconnected from the component it drives and securely mounted on a fixture or mounting plate. These tests are usually conducted when a motor has been removed for any reason other than failure
2. Turn the motor shaft slowly by hand. Feel and listen for evidence of a failed bearing, which is indicated by a rough feel as the shaft rotates, and by noise.
3. Check for smooth rotation, with no evidence of binding or catching. If the shaft does not rotate smoothly, or binds or catches, the bearings are worn or failing, lack lubrication, or are contaminated.
4. Check the motor shaft for side play by applying pressure at right angles to the shaft in several places around the circumference. If the shaft moves perceptibly, the front bearing is worn.
5. If the motor shaft feels rough as it is turned or makes unusual noise, the motor bearings are failing, lack lubrication, or are contaminated. Replace the motor bearings, or clean and re-lubricate the bearings, as applicable. Refer to the REPAIR section.
6. If the bearing shaft shows play in the bearing, the bearing is worn or failing. Replace the motor bearings according to the REPAIR section.

B. Dynamic Testing

1. Find the motor voltage and rated load current values as listed on the motor nameplate.
2. Using a volt-ohmmeter, verify that the motor power supply is in the correct range.
3. Run the motor with no load. As the motor is operating, listen for unusual motor noise and check for excessive vibration. Vibration and motor noise are indications of bearing contamination, lack of lubrication, damage, or failure.
4. Use an ammeter to measure the no-load current. Record the no-load current for comparison with previous readings, and for reference during future testing.
5. If the motor passes the no-load test, operate the motor at rated load and check and record the current.
6. Check the motor operating temperature at rated load. If the motor operates at a higher than normal temperature, the motor is failing.
7. If the motor has an integral brake, check the brake operating temperature. If the brake operates at a higher than normal temperature, the brake is not releasing completely. Refer to the REPAIR section.

3. Fault Isolation

If the motor has failed or does not meet the requirements of any of the tests described above, use the fault isolation procedures provided in Table 4, Motor Fault Isolation. The table is based on the assumption that the motor has been operating correctly, and that a problem has occurred. If a newly installed motor does not operate correctly, the problem is an installation problem.

Fault	Check	Corrective Action
Motor doesn't operate	Check the circuit breaker.	The breaker has tripped. Reset the breaker. If the breaker trips immediately, the motor windings have shorted. Replace the motor.
	Check the motor and the gearbox separately to determine which has failed.	Replace the motor or the gearbox, as applicable.
	If the breaker has not tripped, check the power circuitry to the motor.	If the power circuitry has opened, repair the power circuitry.
	Check for an open in the motor windings.	If the motor windings have an open circuit, replace the motor.
Motor is noisy	Separate the motor from its gearbox and check the shaft bearings by hand according to the TEST instructions.	If the bearings feel rough, replace the bearings according to the instructions in REPAIR.
Motor thermal protection trips	Check the motor exterior for an excessive accumulation of oil and dirt that can inhibit cooling.	If the motor exterior is excessively dirty, clean the motor surface using clean, lint-free cloths. If the motor has a finned casing, use a vacuum cleaner and a stiff-bristled nylon brush to remove dirt and debris from between the fins.
	If the motor has a vented enclosure, check the vent openings to make sure they are clear.	If necessary, clean the vent openings.
	Visually check for heat-discolored paint, which is evidence of a motor overheat.	If the motor casing shows heat discoloration, the motor is failing. Replace the motor.
	Check the system load.	If the load applied to the system is above rated load, it should be reduced, if possible, to avoid affecting motor life.
Motor slows during operation	Check for increased load.	If the load has increased beyond rated load, correct the overload condition to prevent damage to the motor.
	Check for supply voltage drop.	Supply voltage must be within 10 percent of nominal voltage. If the supply voltage is less than 90 percent of rated voltage, correct the supply voltage to avoid damage to the motor.
	Check the gearbox and the motor bearings for wear and drag that increases as the system temperature rises.	If the gearbox drag increases during operation, repair the gearbox. If the motor bearing drag increases as the motor operates, replace the bearings according to REPAIR.

Table 4. Motor Fault Isolation

LUBRICATION

1. General

NORD motor frame sizes 63 up to and including 225 are prelubricated, therefore require no lubrication during normal operation.

Frame sizes 250 and larger will have grease fittings for regreasing the motor bearings. Relubricate bearings every six months (more often if conditions require) using a polyurea base grease, No. 2 consistency & stabilized against oxidation.

REMOVAL, INSTALLATION, AND HANDLING

1. General

Removing, installing, and handling any NORD electric motor follow the same general procedures. Follow the general procedures provided below. Observe all WARNINGS and CAUTIONS.

If you have any questions about the procedure to use to handle, install, or remove a specific motor, call NORD Gear Corporation. Please read the following WARNINGS & CAUTIONS prior to any work on the motor.

WARNING:



IF THE MOTOR HAS AN INTEGRAL BRAKE, VERIFY THAT THERE IS NO LOAD ON THE GEARBOX BEFORE RELEASING THE BRAKE. THIS WILL PREVENT POSSIBLE INJURY AND POTENTIAL EQUIPMENT DAMAGE FROM A DROPPED LOAD.

WARNING:



THE MOTOR ELECTRICAL POWER HAS DANGEROUS CURRENT LEVELS. TO PREVENT SERIOUS INJURY, SHUT DOWN THE POWER TO THE MOTOR AT ITS CIRCUIT BREAKER OR POWER SWITCH BEFORE REMOVING OR INSTALLING ANY MOTOR. LOCK OUT THE BREAKER OR SWITCH AND POST IT WITH AN "OUT OF SERVICE" PLACARD.

WARNING:



LARGE MOTORS ARE HEAVY, EASY TO UNBALANCE, AND ARE AWKWARD TO LIFT AND MOVE. EVEN SMALLER MOTORS ARE HEAVY. HAVE ASSISTANCE WHEN LIFTING AND MOVING HEAVY MOTORS. IF NECESSARY, USE APPROPRIATE LIFTING DEVICES TO LIFT AND MOVE HEAVY MOTORS.

CAUTION:

TO PREVENT DAMAGE TO THE MOTORSHAFT, BEARINGS, AND THE MATING HUB/SHEAVE IN THE GEARBOX, MAINTAIN SHAFT ALIGNMENT WHILE REMOVING THE MOTOR FROM ITS GEARBOX.

2. Removal

- A. Drain the oil from the mating gearbox, or rotate the motor/gearbox assembly so that the motor is up, to prevent oil from spilling from the gearbox when the motor is removed.
- B. Shut down the power to the motor at the main circuit breaker or power switch. Lock out the breaker or switch and place an "OUT OF SERVICE" placard on the breaker or switch.
- C. Disconnect the wiring to the motor. Tag each wire as it is disconnected.
- D. Prepare the motor for removal by supporting the motor appropriately. For smaller motors, use assistance to steady the motor or support it. For larger motors, use mechanical lifting or support devices to steady and support the motor.
- E. Remove the bolts and washers securing the motor to the its mounting.
- F. Maintain motor shaft alignment, and move the motor away from its mounting pad until the motor shaft clears its mating hub/sheave or gearmesh. If the motor shaft is a keyed shaft, keep the drive key with the motor.
- G. Remove and discard the flange gasket. Clean the gasket material from the flange.

3. Installation with NEMA and IEC Flanges

Refer to NORD Gearbox Inputs Installation and Maintenance Instructions in BIM1009.

- A. Make sure the flanges are clean and free of gasket material. Install a new gasket between the mating flanges, if applicable.
- B. Carefully move the motor to insert the motor shaft and its hub/sheave into the adapter spline, making sure the shaft key enters the mating keyway.
- C. Seat the motor flange against the mating flange. Install the mounting bolts and tighten them securely.
- D. Reconnect the wiring to the motor. Refer to Figure 2 for the motor and options connection diagrams.

4. Removing and Replacing C-Face Motors

- A. Shut off the power to the motor and post the shutoff with an “OUT OF SERVICE” placard. Disconnect the wiring to the motor. Tag each wire as it is disconnected.
- B. Support the motor. Remove four bolts securing the motor to the NEMA or IEC adapter.

NOTE: The bolts securing the motor to the adapter are retained using a medium strength thread locker such as blue Loctite.

- C. Pull the motor straight out from the adapter.
- D. Measure and record the dimension from the coupling to the motor flange. Use this dimension to locate the coupling on the replacement motor.
- E. Install a new drive key in the keyway, staking the key or using Loctite to retain the key in the keyway, according to the following instructions:

- 1) If the drive key is not trapped in the keyway (the keyway is open at both ends), stake and install the drive key as follows:

- a. Make sure the keyway is free of contamination so that the drive key will seat properly.
- b. Add a few drops of an approved lubricant to the keyway.
- c. Place the drive key on an appropriate surface with the shaft side of the drive key up. Stake the key in two places near each long edge to deform the edge outward.

CAUTION: SUPPORT THE MOTOR SHAFT BEFORE STAKING THE KEY TO PREVENT DAMAGE TO THE MOTOR BEARINGS.

- d. Support the motor shaft in V-blocks. Place the key with the staked surface down over the key slot. Place a sheet of copper shimstock, or equivalent, on the drive key and tap it into the keyway using a hammer.
- e. Check the key to make sure it is fully seated and securely retained.

- 2) Install and Loctite the drive key as follows:

- a. Make sure the keyway is clean of old Loctite and is free of oil film.
- b. Apply Loctite primer and medium strength (blue) Loctite to the surface of the key and keyway according to the Loctite instructions.

CAUTION: IF THE DRIVE KEY IS TO BE LOCTITED IN PLACE, CLEAN ALL THE LOCTITE FROM THE SURFACE OF THE DRIVE KEY AND THE MOTOR SHAFT TO PREVENT POSSIBLE BONDING OF THE COUPLING AND SPLINE SHAFT TO THE DRIVE KEY.

- c. Install the drive key and center it in the keyway. Cure the Loctite according to Loctite instructions.

- F. Clean all contamination and corrosion from the mating flanges.
- G. Support the motor and mount it to the adapter.
- H. Apply a medium strength thread locking compound such as blue Loctite to the bolt threads according to the instructions. Install the bolts and tighten them securely.
- I. Reconnect the wiring to the motor. Refer to Figure 2 for the motor and options connection diagrams.

5. Removing and Replacing Integral Motors

- A. Shut off the power to the motor and post the shutoff with OUT OF SERVICE. Disconnect the wiring to the motor. Tag each wire as it is disconnected.
- B. Support the motor and remove the bolts securing the motor to the gearbox.
NOTE: Most integral motor installations have mounting bolts accessible from the motor exterior. If the bolts are not visible, unbolt the input flange from the gearbox. Remove four bolts that mount the motor. Remove and discard the Dubo gaskets from the bolts.
- C. Remove the motor from the gearbox.
- D. Clean the gasket faces on the motor and gearbox, making sure no cleaning debris enters the gearbox.
- E. Check the replacement motor to make sure the motor flange, motor shaft, and motor pinion are identical to the motor that was removed.
- F. Place a new gasket between the gearbox and new motor.
- G. Position the motor on the gearbox, making sure the input pinion meshes with the input gear. Rotate the motor as necessary to align the bolt holes and seat the motor flange. Make sure the gasket remains properly aligned and seated.
- H. Apply a medium strength thread locking compound such as blue Loctite to the bolt threads according to the instructions. Install the bolts and tighten them securely.
NOTE: If the motor/gearbox installation uses an input flange, mount the input flange to the motor using four mounting bolts and new Dubo gasket. Tighten the bolts securely.

CAUTION: DO NOT TO MIX TYPES OF OIL.

- I. Check the gearbox oil level. If necessary fill the gearbox or add oil to bring the gearbox oil to the correct level. Check the installation and maintenance manual for your gearbox to find the correct oil for the gearbox.
- J. Reconnect the wiring to the motor. Refer to Figure 2 for the motor and options connection diagrams.

6. Handling and Lifting

- A. Before lifting any motor, disconnect all electrical connections. Tag each wire as it is disconnected.
- B. Disconnect the motor from the gearbox. Do not lift the motor while it has other equipment attached to it.
- C. If the motor has provisions for a lifting eye, turn in an appropriately sized lifting eye and lock it in place with the locking nut. Lift the motor by the lifting eye using an appropriate lifting device.
- D. If the motor does not have provisions for a lifting eye, seek assistance or use appropriate lifting devices as necessary.

7. Storage

If the motor is not in service, store it according to the following conditions:

- A. Cover the motor and store it in a clean warehouse environment protected from dust and fluids.
- B. If the motor has internal heaters, power the heaters during storage if the storage environment is extremely humid. The heaters will prevent moisture buildup in the motor interior.
- C. Before placing the motor in service, visually inspect the motor exterior for evidence of deterioration during storage. Turn the motor shaft by hand to make sure the shaft turns smoothly and freely.

CONNECTION DIAGRAMS

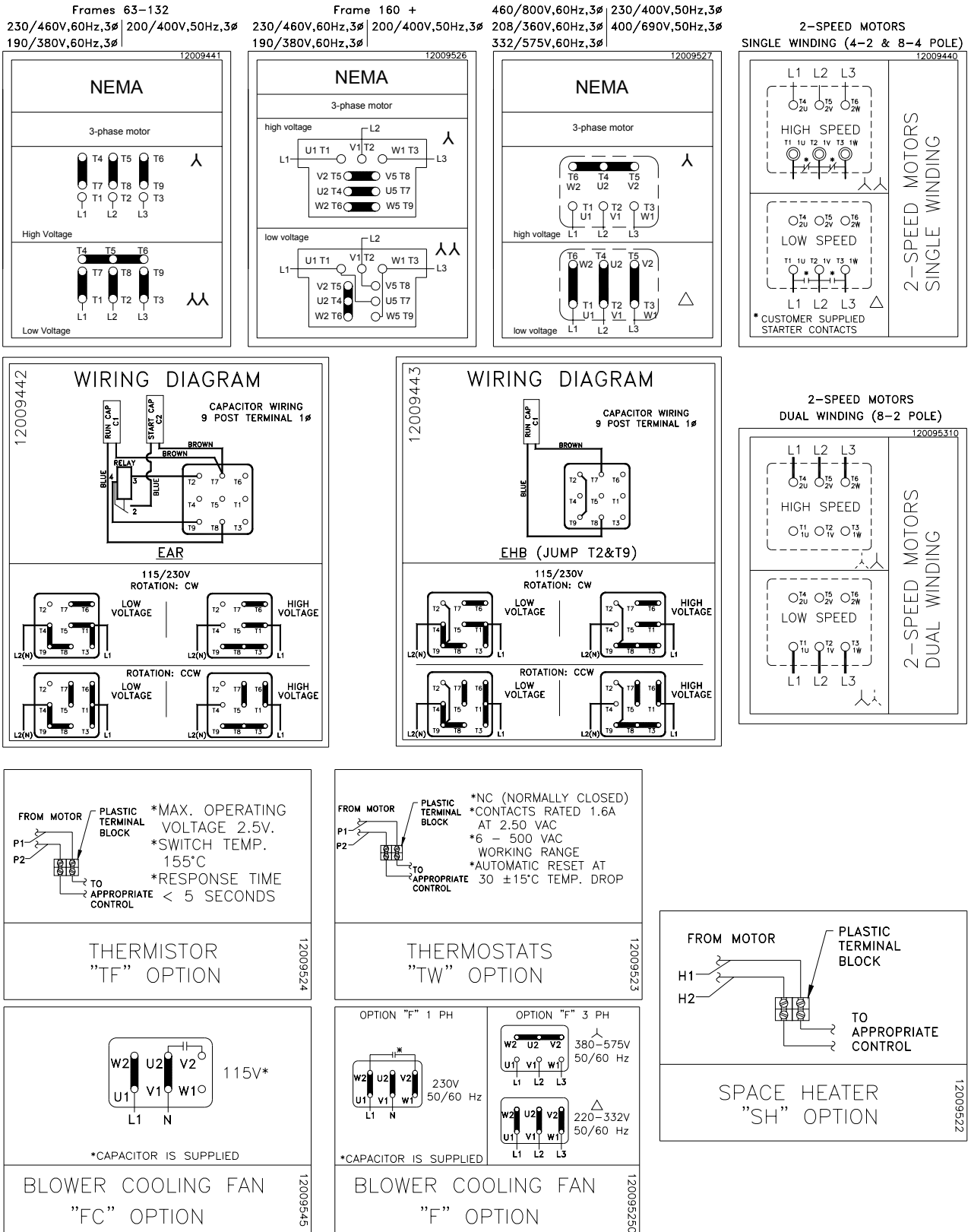

Figure 2. Motor Connection and Wiring Diagrams

REPAIR

1. General

These instructions can be generally applied to NORD motor applications. The exploded view provided in the PARTS INFORMATION section shows the parts orientation for NORD motors.

To procure replacement parts from NORD, contact NORD's customer service department (refer to INTRODUCTION). Provide NORD with the motor part number and serial number, and the item reference number and nomenclature from the parts information figure, which will identify the part for your motor application.

A. The following parts must be replaced if they are removed:

- Oil seal (904), Oil seal (933)
- Gasket (909), Gasket (910), Gasket (921)
- Gasket on plug (961)
- Self-locking screws (907-1, 908-1, 923, 932-1, 940-1)

B. If the following parts are removed, inspect them, and replace them if they are deformed:

- Retaining ring (919), Retaining ring (947), Retaining ring (948)
- Fan clip (952)

C. Disassemble the motor according to the general exploded view in PARTS INFORMATION. Disassemble only as far as necessary to replace the failed parts.

D. Whenever the motor is disassembled, clean all dust and contamination from the motor interior using a vacuum cleaner and a soft-bristled nylon brush.

PARTS LIST

1. General

Refer to Figure 4 for parts information. If you are ordering a part, provide the model and serial number of your motor. This will determine the part number you need.

Part Number	Part Description	Qty per Assembly
900	Rotor Assembly	1
902	A-Endbell	1
904	Oil Seal	1
905	Bearing	1
906	Preload Spring	1
907	T-Box Frame	1
907-1	Screw	4
908	T-Box Cover	1
908-1	Screw	4
909	T-Box Frame Gasket	1
910	T-Box Cover Gasket	1
916	Stator Assembly	1
918	Drive Key	1
919	Retaining Ring	1
920	Oil Plug	1
921	Gasket	1
923	Screw	4
929	Bearing	1
932	B-Endbell	1
932-1	Screw	4
933	Oil Seal	1
939	Fan	1
940	Fan Cowl	1
940-1	Screw	4
947	Retaining Ring	1
948	Retaining Ring	1
952	Fan Clip	1
960	NPT Thread Adapter	1
961	Plug (includes O-ring)	1
***	Spur Drive Gear (alternate to integral bevel gear)	AR
TBLK	Terminal Block	1
TBLK-1	Screw, Terminal Block Mounting	2
ø ø ø	Jumper Bar (not illustrated)	AR

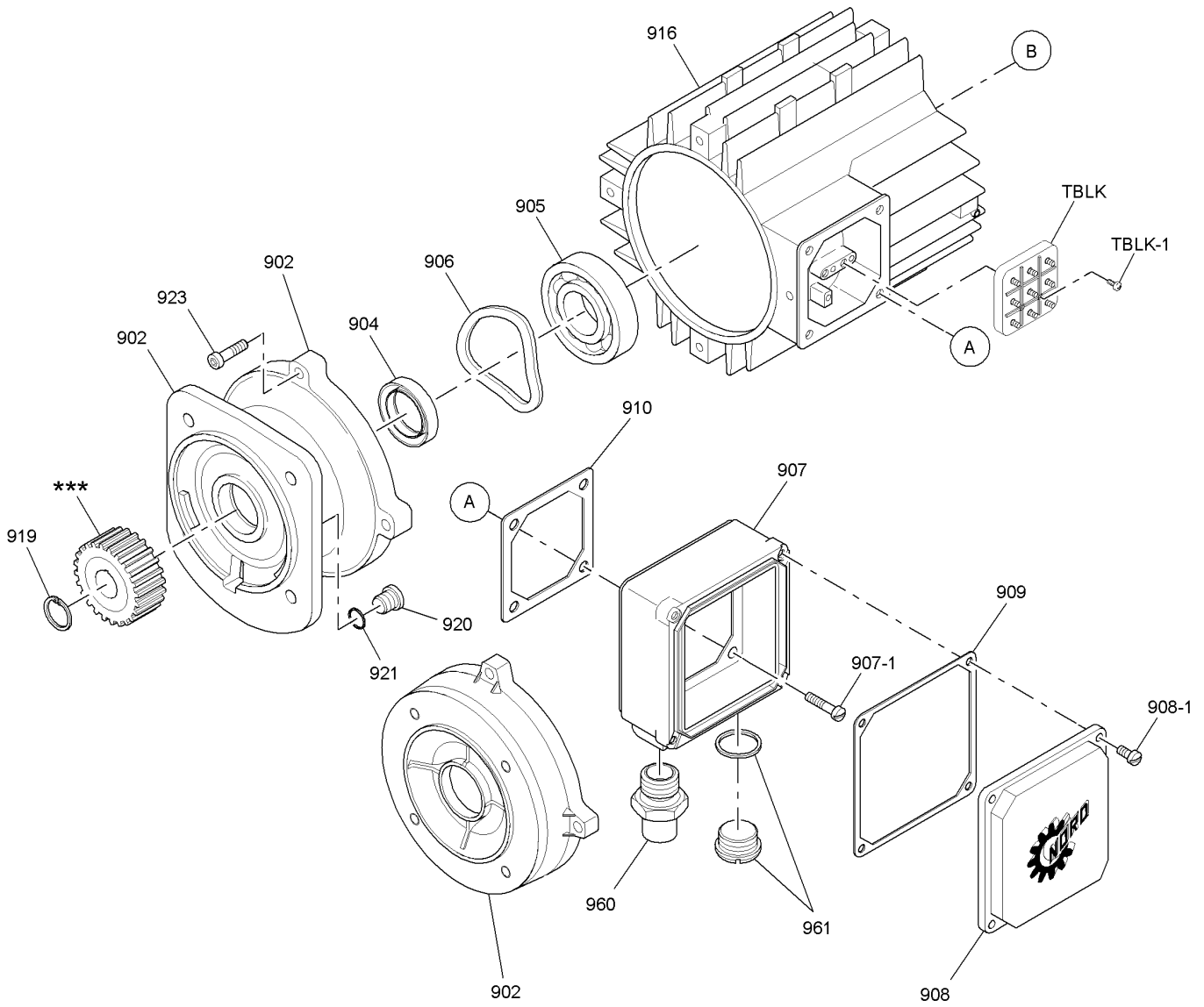

Figure 3. General Motor Exploded View and Generic Parts List (Sheet 1 of 2)

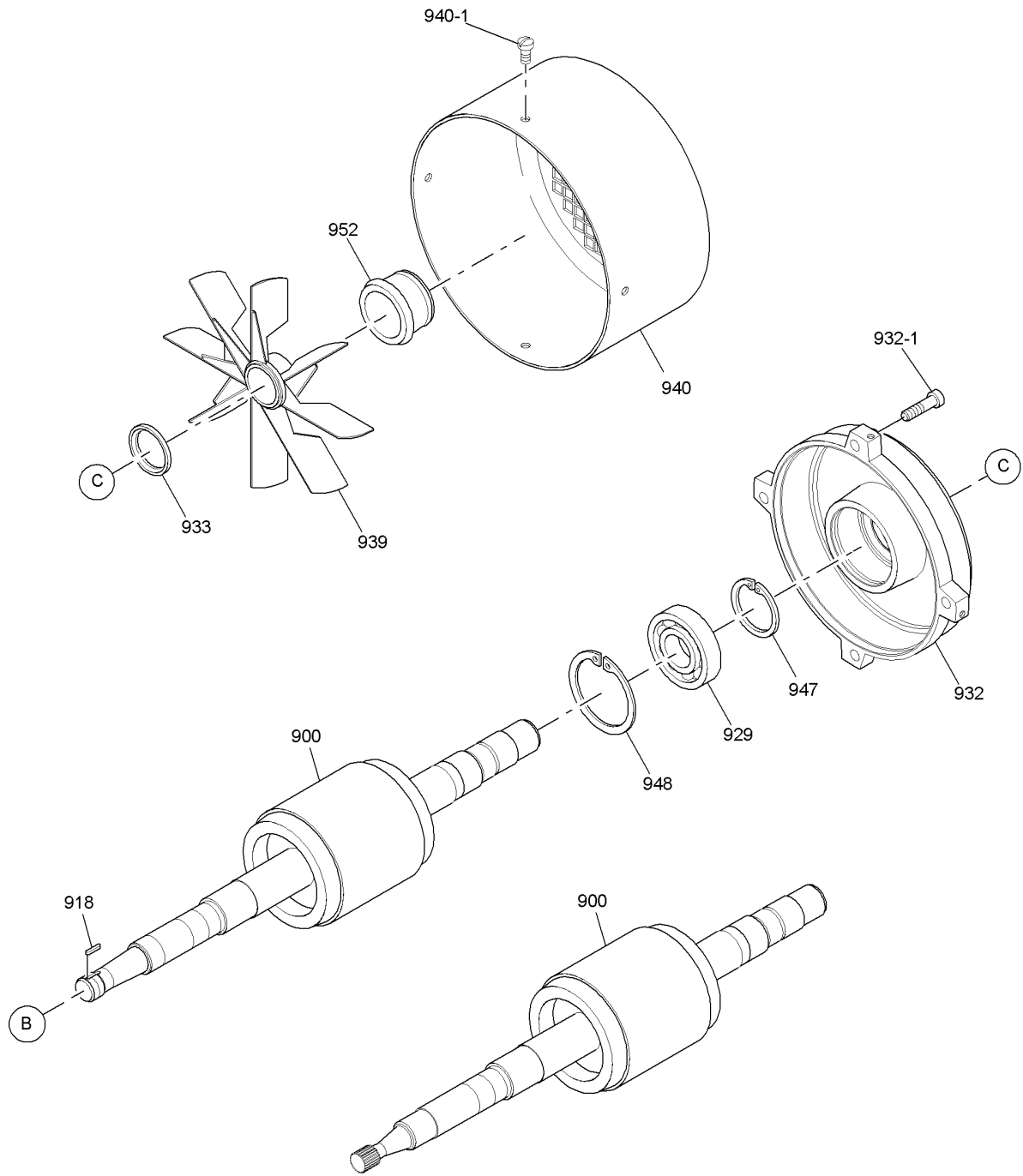

Figure 3. General Motor Exploded View and Generic Parts List (Sheet 2 of 2)

MOTOR OPTIONS & NOMENCLATURE

1. General

NORD offers many options for its motors. The option code will be shown in the motor nomenclature. Below are the available options

Code	Description	Code	Description
BRE	With Brake	OL	TENV Motor – Without Fan
RG	Brake – Corrosion Protected	OL/H	TENV Motor - Without Fan & Cover
SR	Brake – Dust Protected	RD	Canopy Cover
HL	Brake – Manual Hand Release	RDD	Double Canopy Cover
FHL	Brake – Lockable Manual Release	RLS	Backstop
MIK	Brake – Microswitch	SH	Motor Space Heater
IR	Brake – Current Sensing Relay	TF	Thermistor
KD	Condensation Holes	TW	Thermostat
KB	Condensation Holes - Plugged	WE	2 nd Motor Shaft End
MS	Power Plug Connector	WU	High Slip Rotor
NSD+	NORD Severe Duty Plus Protection	Z	High Inertia Motor Ran
EHBU	Single Phase, Run Capacitor	H	Energy Efficient
EARU	Single Phase, Start Cap/Run Cap	IP66	IP66 Environmental Protection
F	Blower Cooling Fan - 3ph & 1ph	ISO H	Class H Insulation
FC	Blower Cooling Fan - 1ph	EP	Epoxy Dipped Windings
IG	Incremental Encoder	FK	Over Running Clutch
VR	5:1 Constant Torque Rated Motor	VN	10:1 Constant Torque Rated Motor
VW	20:1 Constant Torque Rated Motor	VZ-F	1000+:1 Constant Torque Rated Motor

Table 5. Motor Option Codes

Motor Nomenclature					
Motor			Motor Options		
100L	/	4	BRE	40	...
Frame Size		No. of Poles	Brake	Brake size Nm	Other Options

Examples

90SH/4 IG SH

Energy Efficient, 1 Speed, Encoder & Space Heater

100L/4-2 WE RDD

2 speed, 2nd Motor Shaft & Double Canopy Cover

132M/4 BRE100 HL IR TW

Brake, Hand Release, Current Sensor & Thermostat

Technical information follows for THERMISTORS, THERMOSTATS, SPACE HEATERS (Table 6), ENCODERS (Table 7) & BLOWER COOLING FAN (Table 8).

Thermistors (Option TF)

- Connection Diagram shown on Page 12
- Three PTC (Positive Temperature Coefficient) temperature sensitive resistors are wired in series
- One PTC on each phase of the stator winding
- The leads will be labeled P1 and P2 in the terminal box
- This unit must be connected to a Motor Control Protection module such as a Kriwan INT69 or a Variable Frequency Drive with PTC inputs

All wiring must be done by qualified personnel and adhere to all local codes.

WARNING: Thermistors will automatically reset.

Thermistor Ratings:

- Switching temperature 310°F(155°C)
- Maximum operating voltage 2.5 volts
- Resistance at 25°C less than or equal to 300 Ohms
- Response time < 5 seconds

Thermostats (Option TW)

- Connection Diagram shown on Page 12
- Three temperature sensitive, bimetallic switches with normally closed contacts wired in series
- One switch on each phase of the stator winding
- The leads will be labeled P1 and P2 in the terminal box

All wiring must be done by qualified personnel and adhere to all local codes.

WARNING: Thermistors will automatically reset.

Thermostat Ratings:

- Switching temperature 310°F (155°C)
- Switch contacts 1.6A at 250 VAC
- Permissible working 6 to 500 VAC
- Automatically resetting with 30 ± 15°C drop below switching temperature
- Resistance less than 50 mΩ
- Switch rebound less than 1 millisecond
- 10g shock in all directions
- 2,000 VAC Insulation rating
- 10,000 cycles
- Normally closed

Space Heaters (Option SH)

- Connection Diagram shown on Page 12
- Space Heaters are mounted directly on the motor winding
- The leads are brought into the terminal box and labeled H1 and H2
- They require a separate voltage supply and must not be energized when the motor is energized
- The heaters will keep the winding of the motor approximately 5°C above the surrounding ambient

FRAME SIZE	WATTAGE	VOLTAGES	HEATER P/N	HEATER STRIPS/MTR
63 & 71	18W	110V	18900770	1
		230V	18900780	
		460V	18900790	
80	25W	110V	18900820	1
		230V	18900800	
		460V	18900810	
90 – 112	50W	110V	18900820	2
		230V	18900800	
		460V	18900810	
132-180	100W	110V	18900830	2
		230V	18900840	
		460V	18900850	
200 & 225	120W	110V	18900860	2
		230V	18900870	
		460V	18900880	

Table 6. Space Heater Data

Encoder (Option IG)

- Standard encoder manufacturer is Heidenhain (www.heidenhain.com)
- All encoders will be enclosed inside the fan shroud
- Incremental, Quadrature, Differential, Marker Channel
- IP 64 Protection
- IG1 = 1024PPR, IG2 = 2048PPR, IG4 = 4096PPR
- RS422 & Push/Pull available
- 5V or 10-30V available

Color	Signal		Pin (optional mating plug)	Heidenhain Callouts	Explanation
	Push-pull	RS 422			
Pink	---	\overline{B} (B-)	1	$\overline{U_{a2}}$	Signal line
Blue	---	Sensor (+)	2	U_P	Sense Supply Voltage
Red	R (R+)	R (R+)	3	U_{a0}	Signal line (Marker)
Black	---	R-	4	$\overline{U_{a0}}$	Signal line
Brown	A (A+)	A (A+)	5	U_{a1}	Signal line
Green	---	\overline{A} (A-)	6	U_{a1}	Signal line
Violet	---	Spare	7	$\overline{U_{aS}}$	Spare
Gray	B (B+)	B (B+)	8	U_{a2}	Signal line
Yellow	---	---	9	Shield	Spare
White/ Green	0 V	0 V	10	0 V / U_N	Common
White	0 V	Sensor (-)	11	0 V / Sensor	Sense Common
Brown/ Green	V_S	V_S	12	U_P	Supply Voltage

Table 7. Encoder Wiring Designations

BLOWER COOLING FAN (Option F & FC)

- Connection Diagram shown on Page 12
- Option FC is 1 phase 115V only
- Option F has capability of 1 phase or 3 phase by connecting a supplied capacitor

Motor Frame		60 Hz Ratings			50 Hz Ratings		
		Voltage [V]	Current [A]	Power [W]	Voltage [V]	Current [A]	Power [W]
Single Phase Connection - 1~Δ	FC63	100-135	0.23	42	100-135	0.30	42
	FC71	100-135	0.23	47	100-135	0.30	44
	FC80	100-135	0.27	57	100-135	0.30	43
	FC90	100-135	0.46	102	100-135	0.57	78
	FC100	100-135	0.53	105	100-135	0.54	78
	FC112	100-135	0.60	115	100-135	0.55	80
Single Phase Connection 1~Δ	F63	230-332	0.11	38	230-277	0.10	27
	F71	230-332	0.12	41	230-277	0.10	28
	F80	230-332	0.13	44	230-277	0.11	29
	F90	230-332	0.25	88	230-277	0.26	72
	F100	230-332	0.28	88	230-277	0.26	70
	F112	230-332	0.31	107	230-277	0.26	73
	F132	230-332	0.27	89	230-277	0.29	82
Three-Phase Low Voltage Connection 3~Δ	F63	230-332	0.08	23	230-290	0.10	27
	F71	230-332	0.08	24	230-290	0.10	28
	F80	230-332	0.08	25	230-290	0.10	29
	F90	230-332	0.21	64	230-290	0.28	86
	F100	230-332	0.21	66	230-290	0.27	86
	F112	230-332	0.23	70	230-290	0.27	85
	F132	230-332	0.25	74	230-290	0.32	96
	F160	230-332	0.49	165	230-290	0.53	155
	F180	230-332	0.49	165	230-290	0.53	155
	F200	230-332	0.49	165	230-290	0.53	155
	F225	230-332	0.49	165	230-290	0.53	155
Three-Phase High Voltage Connection 3~Y	F63	380-575	0.04	23	380-500	0.05	29
	F71	380-575	0.04	25	380-500	0.05	30
	F80	380-575	0.04	26	380-500	0.05	29
	F90	380-575	0.12	62	380-500	0.16	82
	F100	380-575	0.12	66	380-500	0.16	83
	F112	380-575	0.13	70	380-500	0.16	82
	F132	380-575	0.14	75	380-500	0.18	96
	F160	380-575	0.28	165	380-500	0.30	155
	F180	380-575	0.28	165	380-500	0.30	155
	F200	380-575	0.28	165	380-500	0.30	155
	F225	380-575	0.28	165	380-500	0.30	155

Table 8. Blower Cooling Fan Data



PARTS LIST
TITAN-BELT BOXES
FRAME SIZE: R150
INPUT SIZE: 160s

Parts List No. 715100

IMPORTANT: When ordering parts supply nameplate data:
 1) Serial No., 2) Frame Size, 3) Ratio

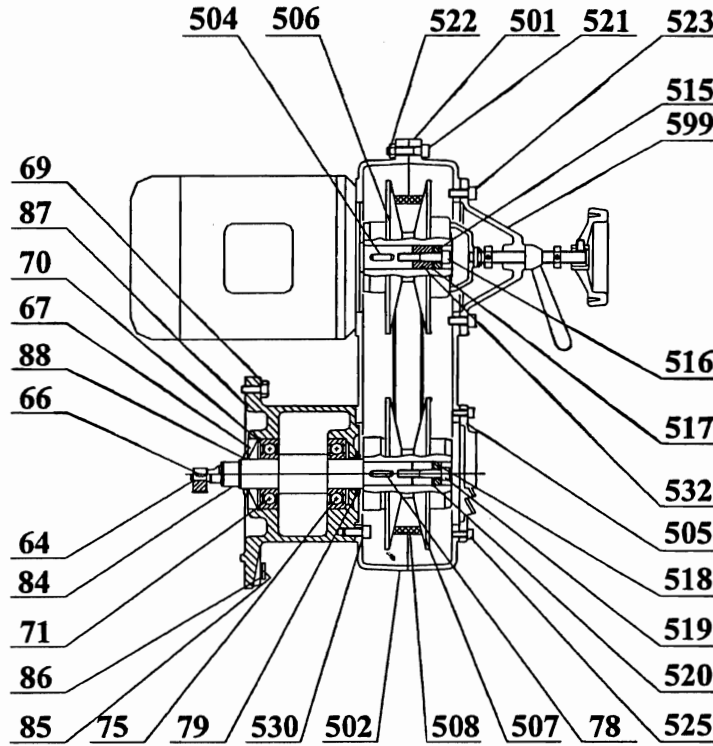

Assembled with
INLINE
SK02
SK11
SK12
SK13
SK23
SK33
CLINCHER
SK1282
SK1382
SK2382
SK3382
BEVEL
SK9012
SK9013
SK9022
SK9023
SK9033
WORM
SK02050
SK12063
SK12080
SK13050
SK13063
SK13080
SK33100

ITEM	PART NAME	DESCRIPTION	PART NO.	QTY	ITEM	PART NAME	DESCRIPTION	PART NO.	QTY
64	SNAP RING	CONTACT	FACTORY	1	506b	ADJUSTABLE PULLEY	7/8in.	71591020	1
66	KEY	CONTACT	FACTORY	1	507	SPRING LOADED PULLEY	24mm	71591110	1
67	OIL SEAL	30x72x10Amm	25030160	1	508	V-BELT	28x8x754LRJ	71592000	1
69	HEX HEAD BOLT	M8x25mm	22008250	4	515a	THRUST WASHER	5/8in.	171082010	1
70	SNAP RING	72mm int.	27307200	1	515b	THRUST WASHER	7/8in.	171082020	1
71	BEARING (BALL)	6306ZZ	24630620	1	516a	SOCKET HEAD BOLT	1/4-20x1-1/4	126504120	1
75	BEARING (BALL)	6306-2RS	24630640	1	516b	SOCKET HEAD BOLT	1/4-20x1-1/2	126504150	1
78	KEY (HARDENED)	3/16x3/16x1in.	126003080	1	517a	SNAP RING	5/8in. int.	127410000	1
79	OIL SLINGER	RB30mmW/WIPER	28583010	1	517b	SNAP RING	7/8in. int.	127414000	1
84	INPUT SHAFT	CONTACT	FACTORY	1	518	THRUST WASHER	m10x23.5x8mm	71582010	1
85	DRAIN PLUG	M10x1.0mm	22110003	1	519	SOCKET HEAD BOLT	M8x45mm	22108450	1
86	GASKET	10x13.5x1.0mm	25310130	1	520	SNAP RING	24mm int.	27302400	1
87	INPUT CYLINDER	160S	50615010	1	521	SOCKET HEAD BOLT	M8x35mm	22108350	6
88	OIL SLINGER	RB30mm	28583000	1	522	HEX NUT	M8	22500800	6
501	BELTCASE	NEMA 143/5	71511120	1	523	SOCKET HEAD BOLT	M8x20mm	22108205	4
502	BELTCASE	NEMA 143/5	71511120	1	525	SOCKET HEAD BOLT	M6x16mm	22106165	2
504a	KEY	3/16x3/16	126003100	1	530	SOCKET HEAD BOLT	M8x20mm	22108205	4
504b	KEY	5/16x5/16	126005090	1	532a	SPACER	5/8x25.21mm	171582510	1
505	VENTILATION COVER		71513110	1	532b	SPACER	7/8x23.62mm	171582520	1
506a	ADJUSTABLE PULLEY	5/8in.	71591010	1	599	HANDWHEEL ADJ. COV.	COMPLETE	71590500	1

a: 56C FRAME MOTOR
 b: 143/145; 184TC FRAME MOTOR

CONTACT FACTORY: THIS APPLIES TO PARTS WHERE A VARIETY OF SIZES ARE AVAILABLE.

6/21/02

NORD GEAR CORPORATION
 800 NORD DRIVE
 P.O. BOX 367
 WAUNAKEE, WI 53597

Telephone: (608) 849-7300
 Fax Number: (800) 373-6673

REED GUNITE MACHINES-MANUAL

SPEED CONTROL ADJUSTMENT PROCEDURES

FOR NORDGEAR ELEC-GEARMOTORS

THIS PROCEDURE IS FOR BOTH THE SOVE/209E-LOHE/215E GUNITE MACHINES. BEFORE ADDING ANY MATERIAL INTO THE REED GUNITE MACHINES'S HOPPER, ADJUST FOR THE DESIRED OPERATING BOWL R.P.M. USING THE FOLLOWING STEPS:

- *TURN ON THE GUNITE MACHINE AT THE CONTROL BOX (FIG. 1)
- *AFTER THE MACHINE IS RUNNING, TURN THE ROUND DIAL THAT IS LOCATED AT BOTTOM LEFT OF THE MACHINE AS FOLLOWS (FIG. 2):
 1. TO INCREASE SPEED-TURN THE DIAL IN A CLOCKWISE MANNER.
 2. TO DECREASE SPEED-TURN THE DIAL COUNTER-CLOCKWISE.(NOTE: ALL REED UNITS HAVE A DECAL THAT INDICATES DIRECTIONS-FIG.3)

THE NORDGEAR UNITS HAVE A BELT-DRIVEN PULLEY ENCLOSED IN A METAL CASE (FIG. 4) . THE BELT GEAR RATIO ON ALL REED UNITS IS 6 TO 1. BY TURNING THE SPEED CONTROL DIAL AT THE BOTTOM OF THE GEARMOTOR, THE DRIVE BELT IS EITHER TIGHTEN FOR MORE SPEED, OR LOOSEN FOR LESS SPEED. THE ELECTRIC MOTOR ALWAYS RUNS AT IT'S MAX R.P.M. IT SHOULD NOTED THAT ALL SPEED CONTROL ADJUSTMENTS ARE TO DONE WHILE THE MACHINE IS RUNNING, FAILURE MAY HAPPEN TO THE BELT AND PULLEYS IF NOT COMPLIED WITH.

SPEED DIAL INFO-(FIG. 5)- SEE SHEET 4 OF 4

FIG. 1



FIG. 2





FIG. 3



FIG. 4



FIG. 5

SPEED DIAL INFO-(FIG. 5)

THE SPEED DIAL IS ACTUALLY A 4 3/4" DIAMETER HANDWHEEL WITH GLASS ENCLOSED DIAL (3 3/8" DIAMETER) IN THE CENTER. THE DIAL HAS 18 GRADUATIONS WITH (2) INDICATORS-(1) BLACK AND (1) RED THAT SHOWS THE RELATIVE POSITION OF THE "SET SPEED". THE SPEED DIAL CONTROLS THE BELT TENSION IN THE GEARBOX AS STATED PREVIOUSLY.



MODEL *LOHE* PNEUMATIC SPRAYING MACHINE
SERVICE BULLETIN

LOHE
SRVBT

PAGE 01

AS WE MAKE IMPROVEMENTS TO THE *REED*
PNEUMATIC SPRAYING MACHINE MODEL *LOHE SERIES 6*,
WE LIKE TO SUPPLY YOU, THE CUSTOMER, WITH
UPDATED INFORMATION WHICH APPLIES TO YOUR PUMP.

THIS SECTION IS PROVIDED AS A PLACE TO STORE
SERVICE BULLETINS AS YOU RECEIVE THEM FROM
REED LLC.

REVISION:



**MODEL *LOHE* PNEUMATIC SPRAYING MACHINE
SERVICE BULLETIN**

***LOHE*
SRVBT**

PAGE 02

THIS PAGE INTENTIONALLY LEFT BLANK.

BULLETIN NO: SB 001
DATE: FEBRUARY 5, 1998
TO: ALL **REED** DEALERS
SUBJECT: **REED WARRANTY PROGRAM**

Each **REED** Concrete Placing Trailer Pump, Truck Mounted Boom Pump and Dry-mix Spraying Gun, undergoes before delivery a thorough Quality Assurance inspection, a performance check and final testing. However, even with these precautions the possibility exists that after delivery, for some reason, a component may fail.

This is the reason for warranty. If this should happen to one of your machines during the first 12 months or 1000 pumping hours after delivery, there is a good chance the failed component could be replaced under warranty.

REED has updated and formalized its **WARRANTY PROGRAM** and this bulletin is issued to make all dealers aware of the program.

Enclosed is a supply of our new **WARRANTY CLAIM** forms. From this point on, all warranty claims must be submitted on these forms. Also, please find a description of the program, coverage and how to make a claim and its submission. We suggest you give this some careful attention. Briefly some noteworthy items are:

- Do not return any failed part unless requested by **REED**.
- Purchase the replacement part through normal channels from **REED**. Submit your claim noting the invoice number of the replacement part. Upon approval of the claim, a credit will be issued.
- Every effort will be made to process claim within 2 weeks from receipt except for those occasions where the part is to be returned.

Should questions arise during your review, please do not hesitate to contact us.

We appreciate the opportunity to be of service.

Sincerely,



Mike Wickstrom
Service Manage

WARRANTY PROGRAM POLICY

REED Pneumatic Spraying Machine MODEL **LOHE** is designed and engineered to perform as stated on published specifications. Only quality materials and workmanship are used in the manufacture of these products. As a back up for the product manufactured by **REED**, a guarantee against defects in design and workmanship of components is provided for each machine.

The **REED** guarantee/warranty states, in general, that **REED** will replace free of charge any components found to be defective within the time frame of the warranty period. There are exceptions to some components which are not the responsibility of **REED**. These are noted elsewhere.

A formal printed policy is available and depicts in more detail the warranty and description. However, for your ready reference the following is offered:

A. WARRANTY PERIOD

- ALL CONCRETE PLACING MACHINES

The warranty period is for twelve (12) months from date of delivery to initial user or 1000 pumping hours whichever comes first.

- NEW PARTS WARRANTY

For parts sold through the **REED** Parts Department the warranty is ninety (90) days from invoice ship date.

- REPLACEMENT WARRANTY PARTS

Replacement parts provided under the terms of the machine warranty are for the warranty period applicable to the unit in which they were installed as if such parts were original components of the machine.

B. WARRANTY COVERAGE

- DEFECTIVE PARTS

Unless otherwise authorized the replacement part **MUST** be **PURCHASED** from **REED**. Once warranty claim is received and approved, **REED** will provide credit to the dealer/user for their cost of the replacement part as invoiced by **REED**.

- LABOR

No labor time and related compensation will be provided by **REED** to dealers/users or others to perform work under this warranty policy.

- TRAVEL TIME

No travel time, mileage or other expenses will be compensated by **REED** to dealers/users or others to perform work under this warranty policy.

- FREIGHT, IMPORT DOCUMENTATION, CUSTOM DUTY

Any expense incurred for freight, import duty and documentation will not be reimbursed by **REED** in association with this warranty policy.

C. EXCLUSIONS

- CHASSIS AND RELATED COMPONENTS (TRUCK MOUNTED UNITS)

The warranty for the chassis is handled by the chassis manufacturer and their dealer network. Prior to putting the truck in service it is suggested you contact the nearest manufacturer dealership.

- ENGINE - TRAILER UNITS

The engine warranty is handled by the engine manufacturer and their dealer network. The terms and conditions of their warranty will apply. Contact the local engine dealer for specifics on warranty of the engine.

- NORMAL WEAR

This pertains to items that have failed as a result of normal wear and tear to the product including but not limited to material cylinder and hydraulic cylinder piston components, delivery systems, pins, chains, bushings, seals, concrete pump wear parts, brakes, filter elements, fluids and tires.

- DAMAGES

Caused by transport of equipment or parts, improper set-up or installation, operator error, improper operation or storage, environmental conditions, accidents, improper mechanical techniques employed by anyone or any other cause other than a structural defect in materials or workmanship.

- MAINTENANCE

Caused by failure to perform any scheduled maintenance or routine maintenance as specified in technical manual on any structural or mechanical component.

- MODIFICATIONS

Any non-authorized changes or modifications of any kind to the product. Any modification must be authorized and approved in writing by **REED** Engineering Department.

- ABUSE

Any accidental or intentional abuse of product including but not limited to neglect, loading beyond capacity or any operation of the equipment beyond the limits set forth by **REED** documentation and as depicted in the appropriate technical manual.

D. SUBMISSION OF CLAIM BY DEALER/USER

Should a component failure be encountered during the warranty period and should it fall within the guidelines of the **REED WARRANTY POLICY** the following procedure is to be followed to claim warranty:

1. REPLACEMENT PART

- Obtain the replacement part by ordering it from the **REED PARTS DEPARTMENT**. through normal channels. You will be **INVOICED** for the part.
- If the part has been previously ordered from **REED** and is in your replacement stock inventory you may choose to use that part.

2. COMPLETE THE CLAIM FORM

REED has supplied you with a pre-numbered Warranty Claim Form which consists of four (4) parts. This and only this form is **ACCEPTABLE**. **DUPLICATE** copies of the form are **NOT ACCEPTABLE**. If you do not have the proper form, contact the **REED** Service Department. They will send you a supply.

The following instructions are offered for completing the **WARRANTY CLAIM FORM**. Refer to sample of form. Circled numbers on form correspond to items below. **FILL IN:**

1. Date your claim is written
2. Distributor name and address
3. End user name and address
4. Model number of unit affected
5. Serial number of unit affected
6. Date unit was first placed in service
7. Hours (from hour-meter) of operation at time of failure
8. Date when failure occurred
9. Date when unit was repaired
10. Return Authorization number as received from **REED** Service Department. This will only apply when failed component is requested to be returned by **REED**.
11. Date when failed part is shipped back to **REED**
12. List **REED** part number, description of part, quantity and price of part.
13. List **REED** invoice number sent you when replacement part was purchased
14. Briefly describe failure and how it occurred
15. Dealers signature and date

The claim form **MUST BE COMPLETELY FILLED OUT**. Claims lacking specific, accurate information will be returned **UNPROCESSED**. If additional room is needed to describe the failure or to list the parts used, attach a separate sheet and identify those sheets with the **SAME WARRANTY CLAIM NUMBER**.

3. SUBMITTING TO **REED**

When all appropriate data has been entered on the claim and signed, proceed as follows:

- Remove copies of form marked “**DEALER**” (yellow) and “**RETURN AUTHORIZATION**” (green). The Dealer copy is for your records and the Return Authorization copy is to be retained in the event **REED** requests the return of the part.
- Mail the “**REED**” copy (white) and “**ACCOUNTING**” copy (pink) along with any back-up data such as a copy of the replacement part **INVOICE** to **REED**. **DO NOT FAX COMPLETED FORM** and send only **FORM ORIGINALS**.

E. RETURN OF FAILED COMPONENT

Depending on the type of part and circumstance surrounding the component failure, the possibility exists that **REED** may request that the failed part be returned to them for investigation and evaluation purposes or to apply for warranty from the manufacturer of the part.

- Upon receipt of your warranty claim and before claim is approved, **REED** will inform you in writing if the part is to be returned. On this correspondence a **RETURN AUTHORIZATION** number will be given to you.
- This number is to be written in the appropriate area on the **RETURN AUTHORIZATION** copy (green) of the warranty form. Include this copy as part of your packing slip. Also write the number on a tag and attach to the part.
- Parts requested to be returned must be shipped back to **REED** within 30 days from issuing of the **RA** number. Failure to do so will cause warranty claim to be **DENIED**.
- Returned parts are to be properly packaged and shipped freight **PREPAID**.
- Any parts received by **REED** without the **PROPER RA** number will be shipped back at **DEALER/USER EXPENSE**.
- If claim is approved and no request to return parts from **REED** has been made, then parts can be discarded.

