

HYDRAULIC AND ELECTRICAL SCHEMATICS

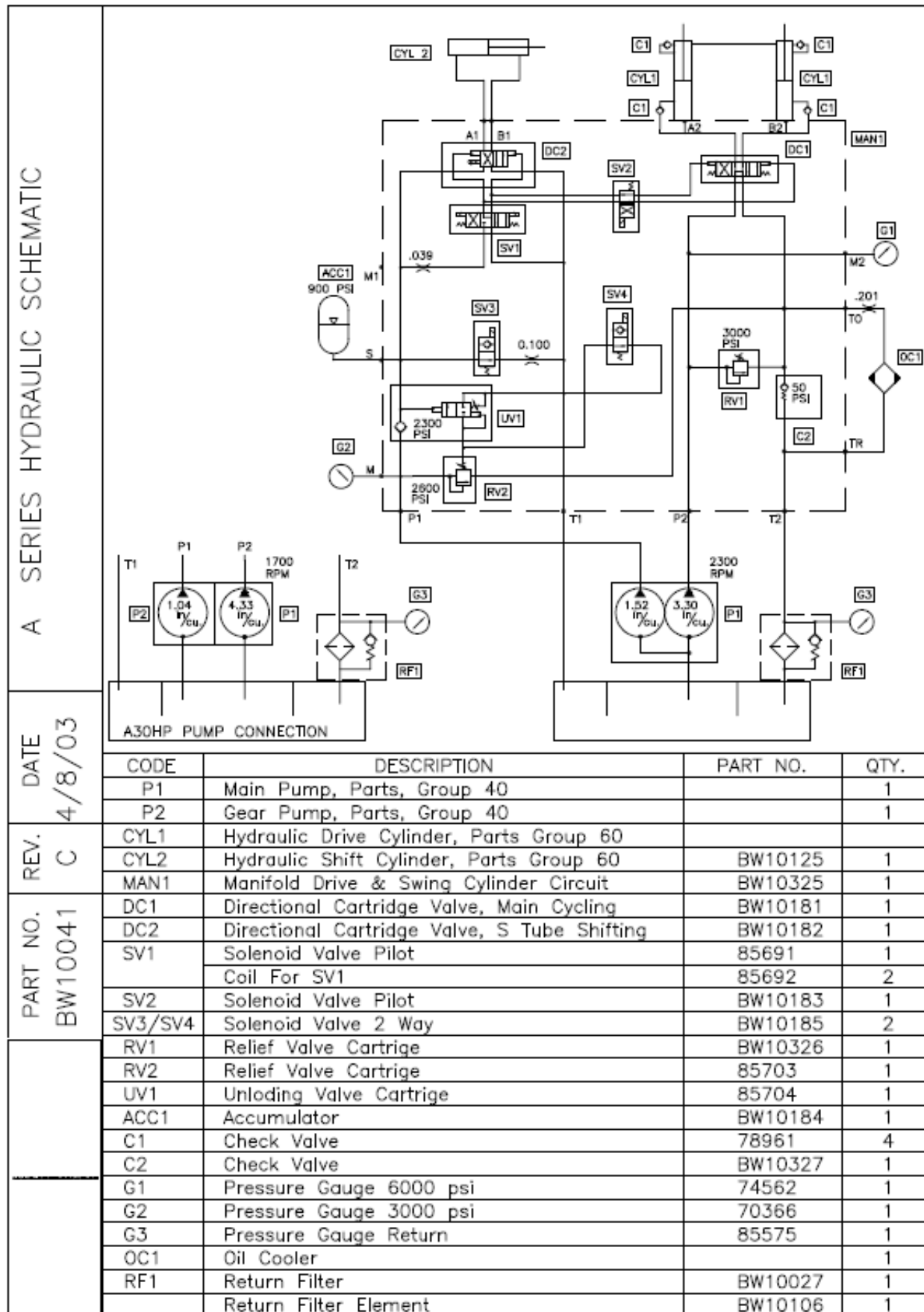

1 2 3 4 5 6 7 8

REVISION 9/10/04

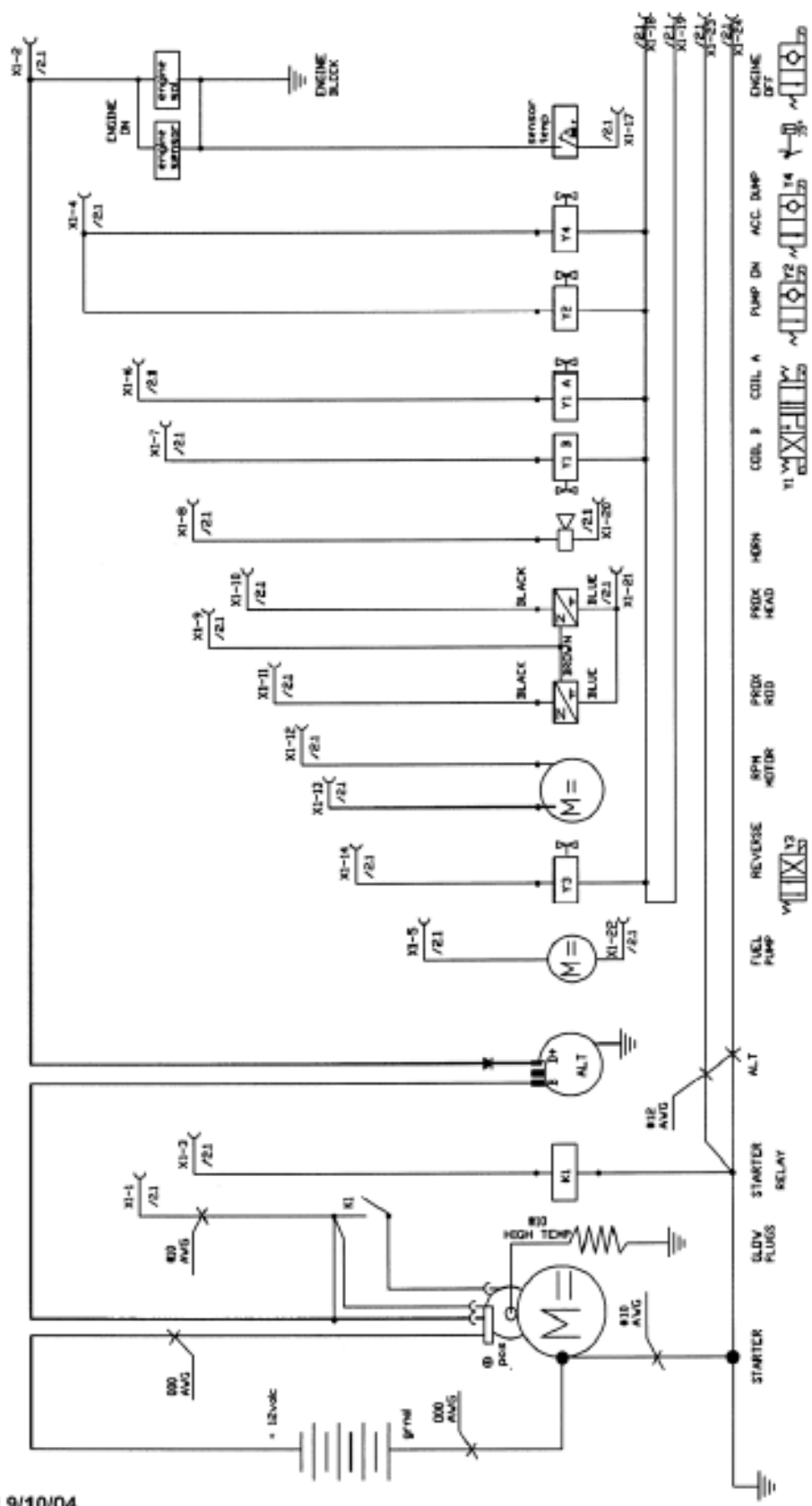

Wiring Diagram: Engine Control System

REVISION 9/10/04

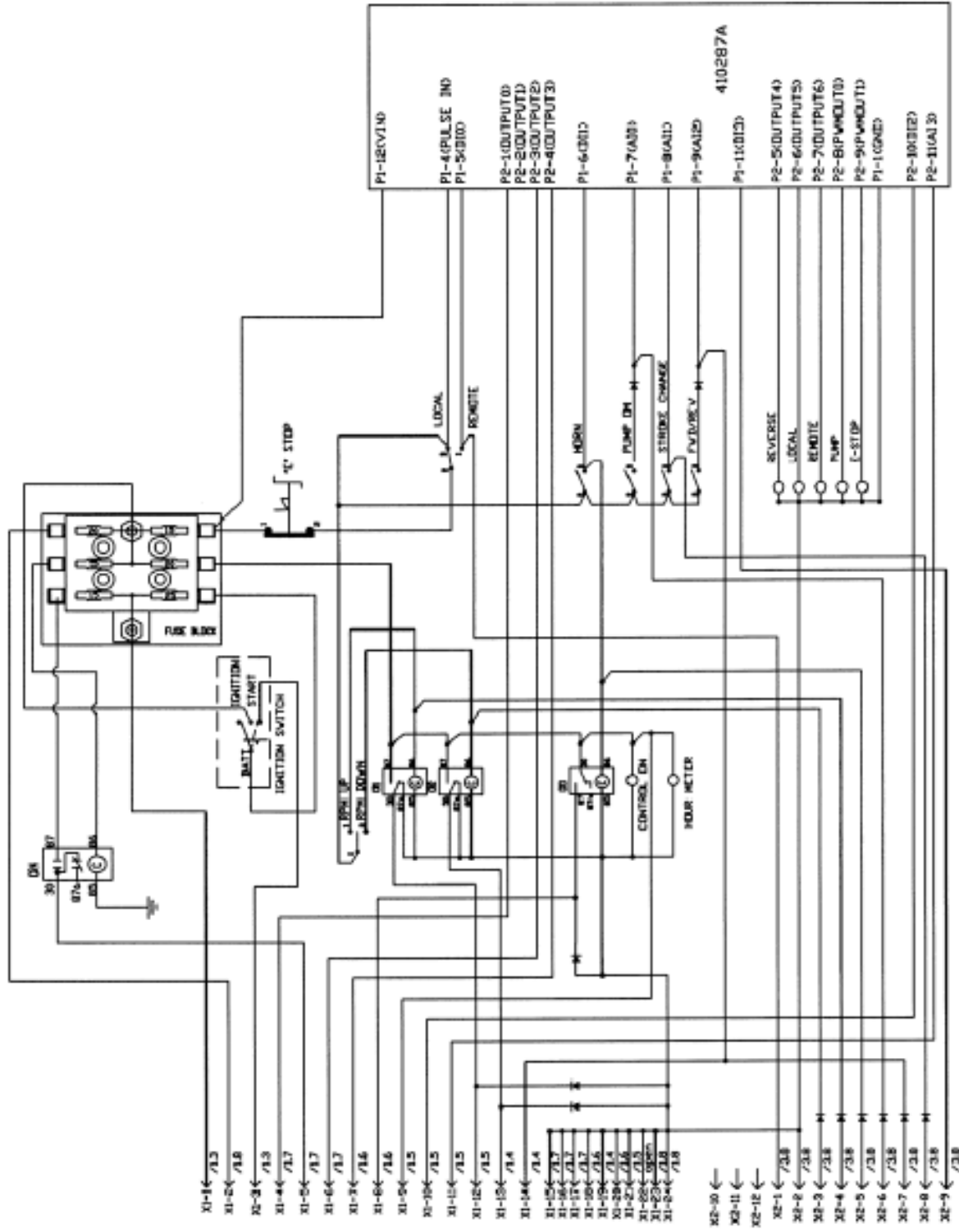

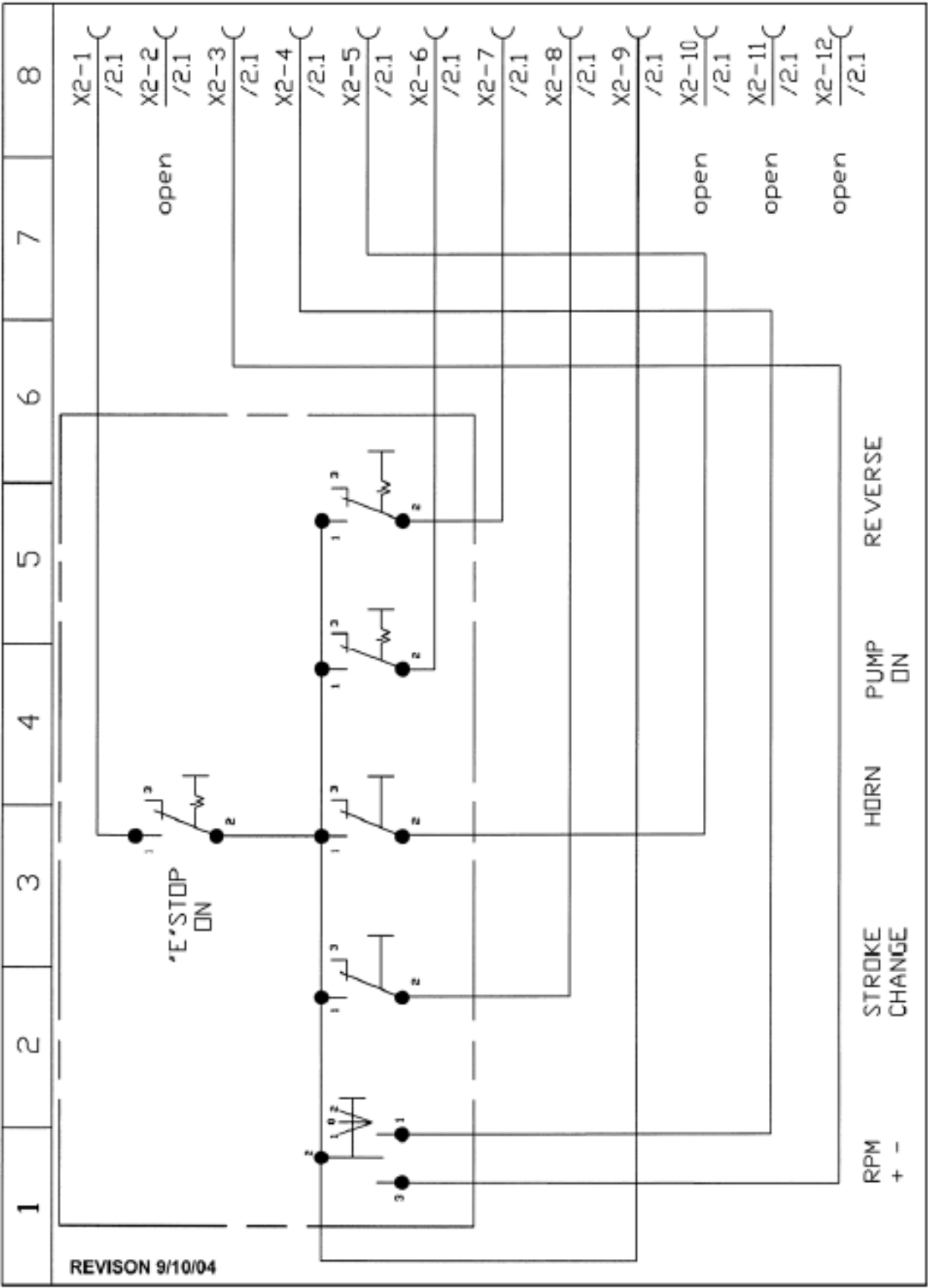

DEUSCH CONNECTOR PARTS

PLUG BW10145
 BOOT BW10146
 PINS BW10147

24 PIN WIRE
 PLUG NUMBERS
 X1

- #20 - - - - - HORN
- #8 + - - - - - HORN
- #13 - - - - - RPM
- #12 + - - - - - RPM
- #19 - - - - - REVERSE
- #14 + - - - - - REVERSE
- #6 - - - - - COIL "A"
- #18 + - - - - - GROUND
- #7 - - - - - COIL "B"
- #4 - - - - - ACCUM DUMP +
- #15 + - - - - - REMIXER DUMP +
- #11 - - - - - PROX SWITCH "B"
- #9 - - - - - PROX SWITCH +
- #21 - - - - - GROUND
- #10 - - - - - PROX SWITCH "A"
- #16 + - - - - - PROX SWITCH +
- #17 - - - - - PROX SWITCH "GRATE"
- #1 - - - - - BATTERY +
- #2 - - - - - ENGINE SOL.
- #3 - - - - - ENGINE SOL.
- #3 - - - - - ENGINE START
- #23 - - - - - GROUND
- #24 - - - - - GROUND
- #22 - - - - - GROUND
- #5 - - - - - FUEL PUMP +

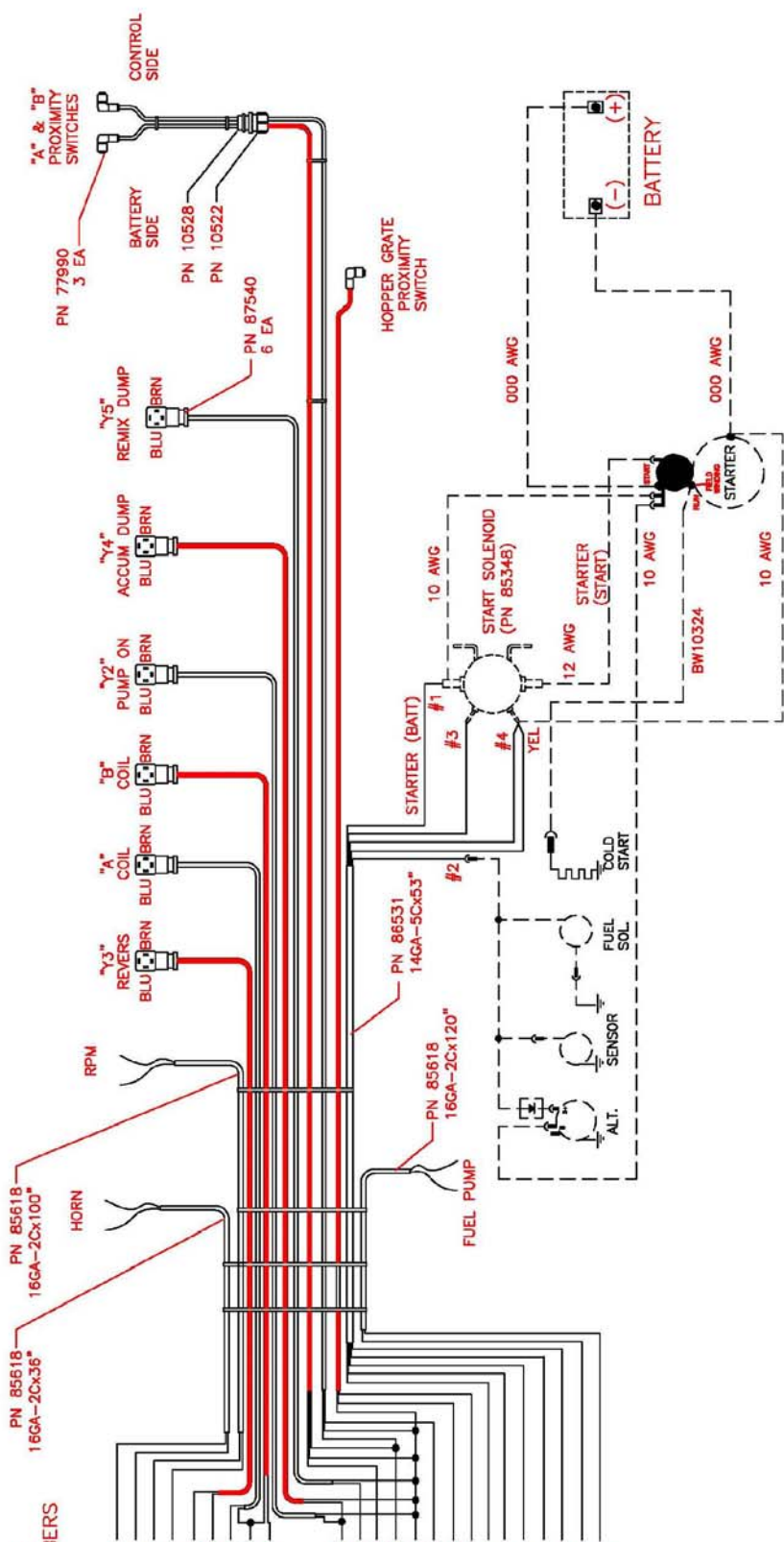

DO NOT SCALE DRAWING		CONCRETE PLACING EQUIPMENT	
UNLESS OTHERWISE SPECIFIED, DIMENSIONS ARE IN INCHES.		CHINO, CA 91710	
TOLERANCES: .XX .030 .XXX .010 FRACTION 1/32 ANGLE 1/2		TITLE REED WIRING HARNESS, A SER, BW10039-2	
DRAWN SK	1/30/08	PART NUMBER	BW10414
BY		REV	
REV	DATE	DESCRIPTION OF CHANGE	
REVISIONS			
		SHEET 1 OF 1	

THIS DRAWING IS THE PROPERTY OF REED MANUFACTURING AND IS TO BE USED ONLY FOR THE EQUIPMENT AND PARTS SPECIFICALLY IDENTIFIED THEREON. IT SHALL NOT BE REPRODUCED, COPIED, LOANED, OR DISPOSED OF, DIRECTLY OR INDIRECTLY, NOR USED FOR ANY PURPOSE OTHER THAN THAT FOR WHICH IT IS SPECIFICALLY FURNISHED.

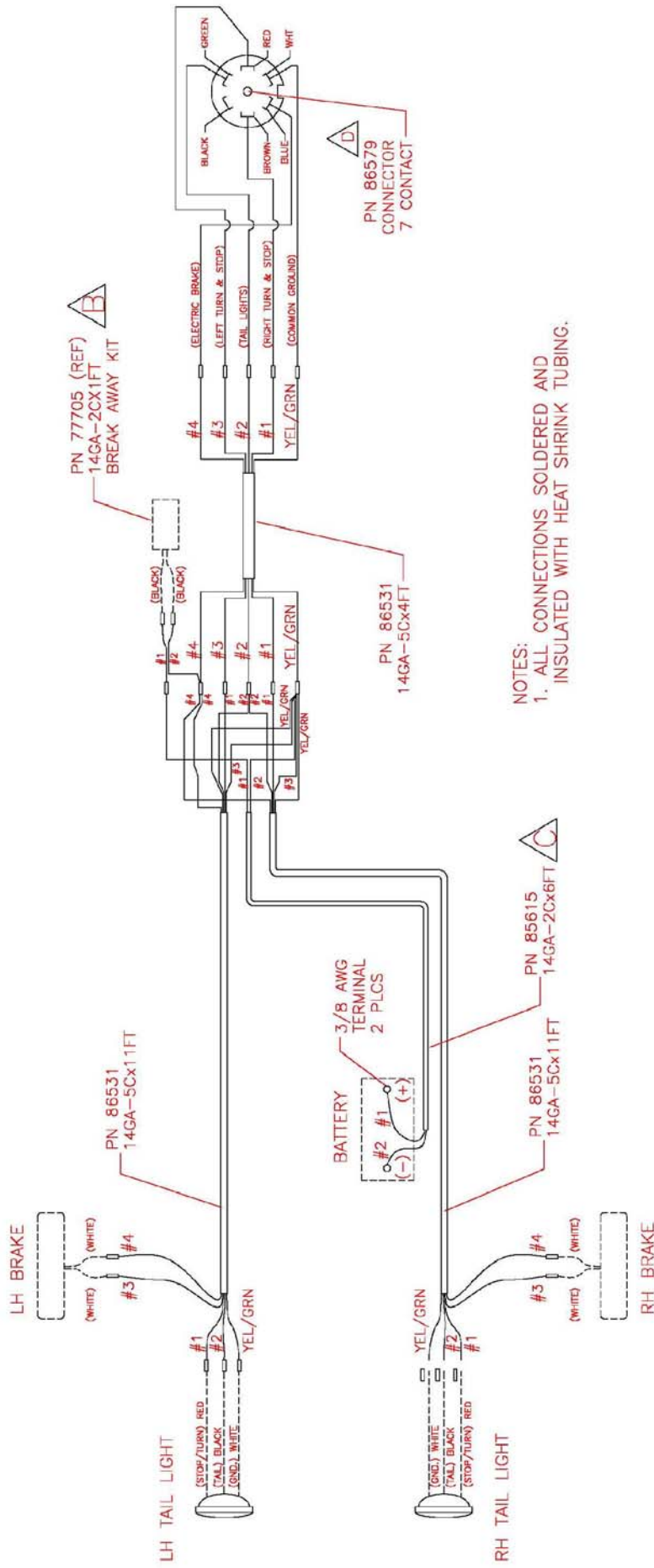

NOTES:
1. ALL CONNECTIONS SOLDERED AND INSULATED WITH HEAT SHRINK TUBING.

REV	DATE	DESCRIPTION OF CHANGE	BY	APPROV
D	3/19/07	ECN#12000	SK	
C	06/11/02	ECN#596	HR	
B	06/11/02	ECN#536	HR	
A	03/12/02	ECN#490	HR	

DO NOT SCALE DRAWING	UNLESS OTHERWISE SPECIFIED, DIMENSIONS ARE IN INCHES.	TOLERANCES:
		.XX .030
		.XXX .010
		FRACTION 1/32
		ANGLE 1/2°

DO NOT SCALE DRAWING	UNLESS OTHERWISE SPECIFIED, DIMENSIONS ARE IN INCHES.	TOLERANCES:	DRAWN SK	DATE 1/22/02
		.XX .030		
		.XXX .010		
		FRACTION 1/32		
		ANGLE 1/2°		

REV	DATE	DESCRIPTION OF CHANGE	BY	APPROV

TITLE	MATERIAL	PART NUMBER	REV
CONCRETE PLACING EQUIPMENT CHINO, CA 91710	TRAILER HARNESS, A SERIES	BW10139	D

REVISIONS
SHEET 1 OF 1

APPLICATION NOTES:

The following connections are made through the REED Interface Cable, p/n HAR4002.

1. Remote Power Return

The system will provide a +12Vdc signal on pin 9 of the Reed connector when the remote handheld unit is turned ON.

2. Pump On/Off

The system provides a +12Vdc signal on pin 6 of the Reed connector when the remote Pump On button is pressed. When the Pump Off button on the remote is pressed, the +12Vdc signal is removed.

3. Pump Forward/Reverse

The system provides a latched +12Vdc signal on pin 7 when the Reverse button is pressed. When the Forward button is pressed, the +12Vdc signal is removed.

4. Engine Throttle

A +12Vdc voltage will be present (momentary operation) between pins 3 and 4 of the Reed connector when the Throttle Up button is pressed.
A negative 12Vdc voltage will be present on these same pins when the Throttle Down button is pressed.

5. Pump Stroke Change

A momentary +12Vdc signal will be placed on pin 8 of the Reed connector when the Volume Up button is pressed.

6. Horn

A momentary +12Vdc signal will be placed on pin 5 of the Reed connector when the Horn button is pressed.

7. Power Connections

System power must be provided through a keyed and fused +12VDC power source. The system must be fused with a 10 amp fuse.
The receiver must also be connected to a suitable electrical ground. These connections are made through the pins 1 and 2 of the Reed connector respectively.

8. Antenna Connection

Mount the antenna to the top side of the concrete pumper cowling. Connect the antenna to the receiver using the supplied 5 foot coax cable.
Using cable ties, affix the cable to suitable locations to prevent flexing due to vibration. Excessive flexing can cause the internal conductor to suffer fatigue and break.

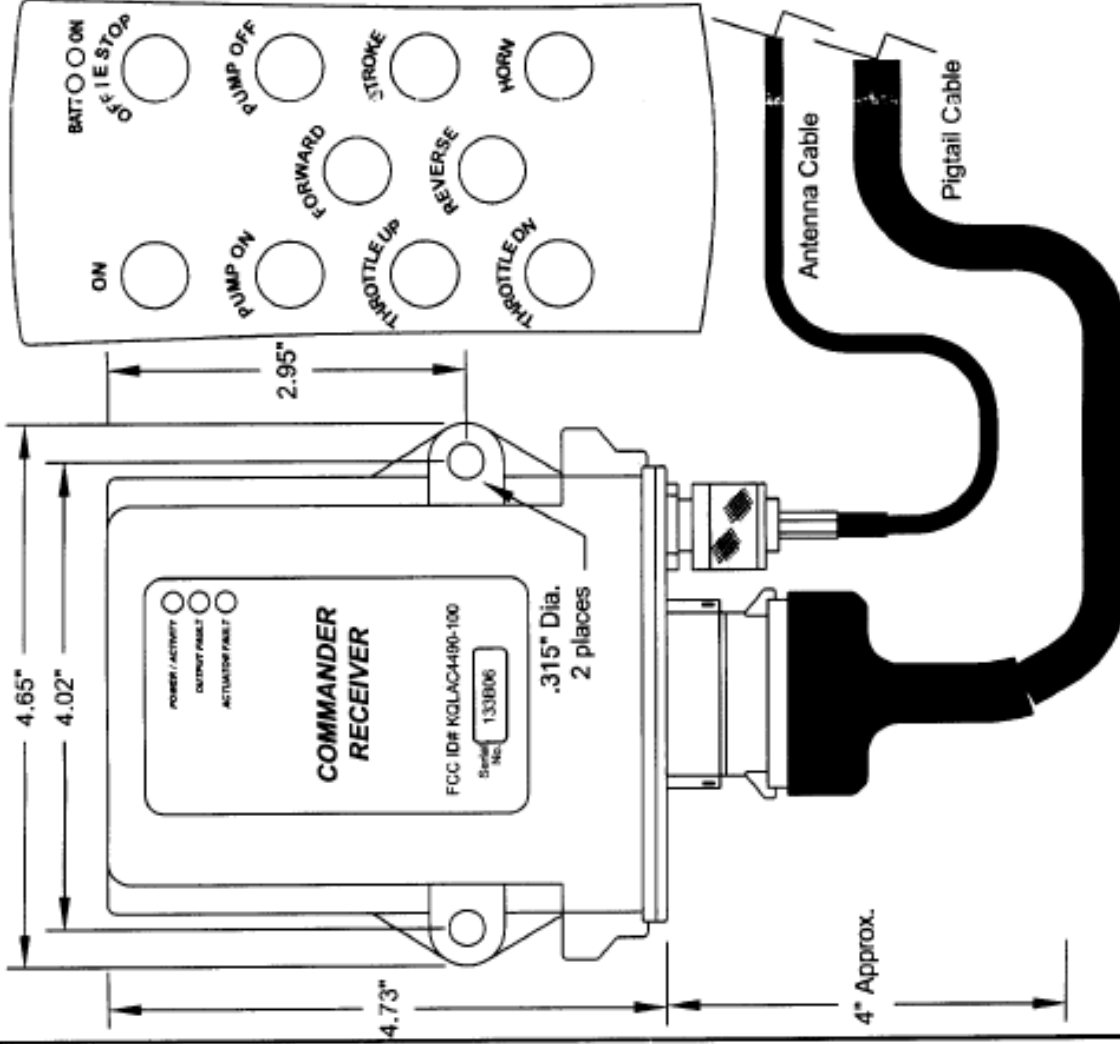

Title Concrete Pumper System REED Series A Type		
Size A	Number 20030	Rev 3
Date October 24, 2008	Drawn By MGS	
Filename 20030Ar3.dwg		Sheet 1 of 4

REED Series A Controller Unit

For specific detail on the connections to the Series A controller, please consult REED drawing No. 41-028-6-A and the table below.

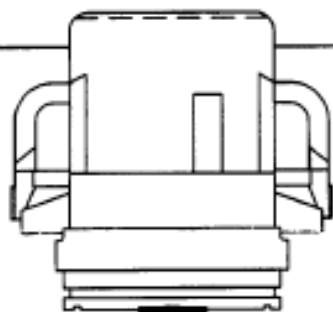

REED Controller Connector

Interface Cable
from **BASE** Receiver

SYSTEM CONNECTION

Base Pin #	Colour	Base Function	Reed Pin #	Reed Function
1	Blue	CH4 Output	9	Remote to Power Return
2	White	CH3 Output	5	Horn
3	Green	CH2 Output	7	Pump Reverse
4	Black/White	RS232 TX	N/C	-
5	Blue/Black	RS232 RX	N/C	-
6	Red	V/Batt (Power In)	1	Remote Power
7	Green/Black	Bridge Output 2-1	8	Pump Stroke Change
8	Orange/Black	Bridge Output 2-2	N/C	-
9	Red/Black	Bridge Output 1-2	3	Throttle Down
10	White/Black	Bridge Output 1-1	4	Throttle Up
11	Orange	CH1 Output	6	Pump On
12	Black	GND	2	Remote GND

BASE ENGINEERING INC.
WIRELESS INDUSTRIAL CONTROLS

Title Concrete Pumper System
REED Series A Type

Size **A** Number **20030** Rev **3**

Date October 24, 2008 Drawn By MGS

Filename 20030Br3.dwg Sheet 2 of 4