

REED 4040B CONCRETE PUMP

SECTION 10:

PARTS INFORMATION, WARRANTY & SERVICE

PAGE

1	AXLE & FRAME ASSEMBLY
2	CONTROL PANEL
3	POWER TRAIN ASSEMBLY
4	HYDRAULIC VALVES
5	MAIN HYDRAULIC PUMP
6	FLUSHBOX AREA
7	CONCRETE & HYDRAULIC CYLINDERS
8	SWING TUBE ASSEMBLY, OUTLET, HOPPER
9	REAR HYDRAULIC TANK
10	AGITATOR ASSEMBLY

FRAME & AXLE ASSEMBLY

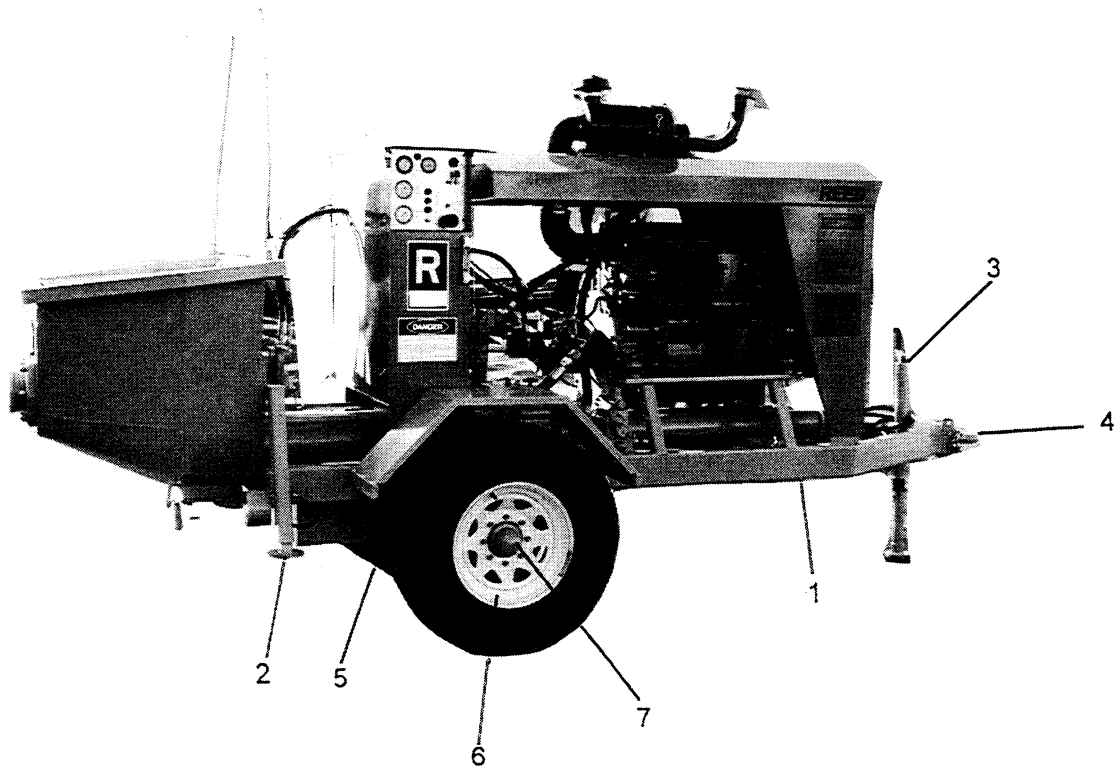

<u>ITEM</u>	<u>DESCRIPTION</u>	<u>PART #</u>	<u>QTY</u>
1	FRAME WELDMENT	77935	1
2	REAR JACK STAND	76018	2
3	TOP WIND JACK	71060	1
4	LUNETTE EYE 3"	71051	1
5	AXLE	71005	1
6	WHEEL AND TIRE	71066	2
7	DUST CUP	71199	2

CONTROL PANEL

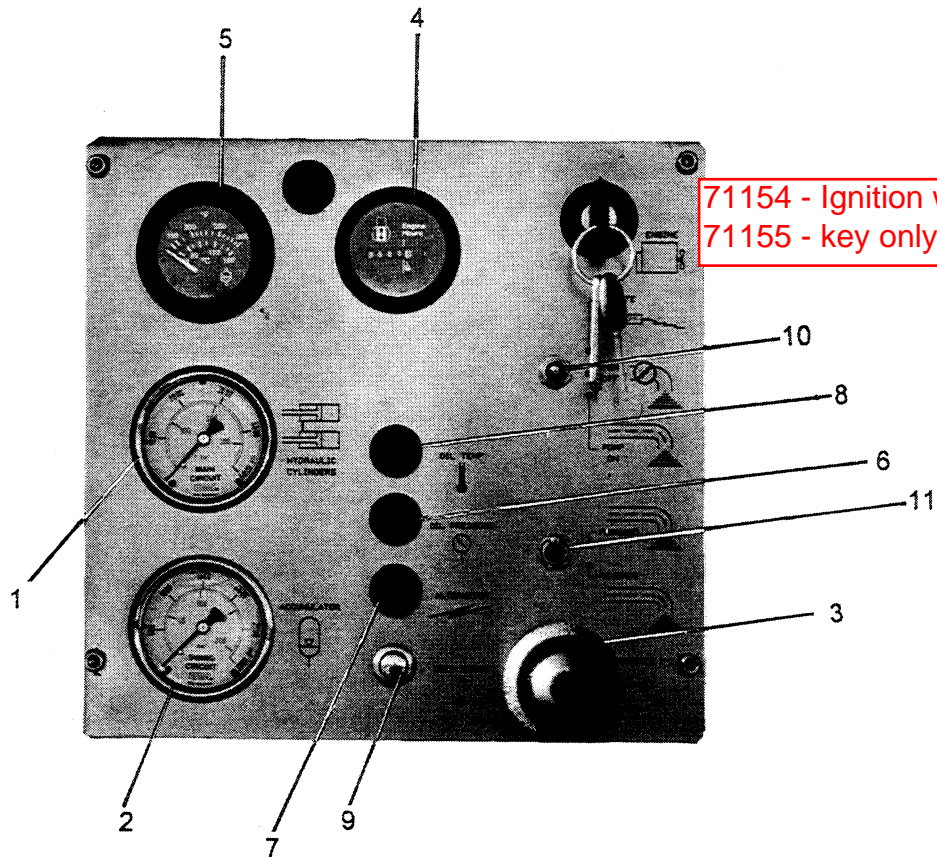

<u>ITEM</u>	<u>DESCRIPTION</u>	<u>PART #</u>	<u>QTY</u>
1	0-5000 PSI GAUGE	74562	1
2	0-3000 PSI GAUGE	70366	1
3	THROTTLE CABLE	78201	1
4	TACHOMETER	71119	1
5	WATER TEMPERATURE GAUGE	78203	1
6	INDICATOR LIGHT (GREEN)	73776	1
7	INDICATOR LIGHT (AMBER)	73777	1
8	INDICATOR LIGHT (RED)	73775	1
9	SWITCH	72863	1
10	ON-OFF-ON SWITCH	72965	1
11	ON-OFF SWITCH	72963	1

POWER TRAIN ASSEMBLY

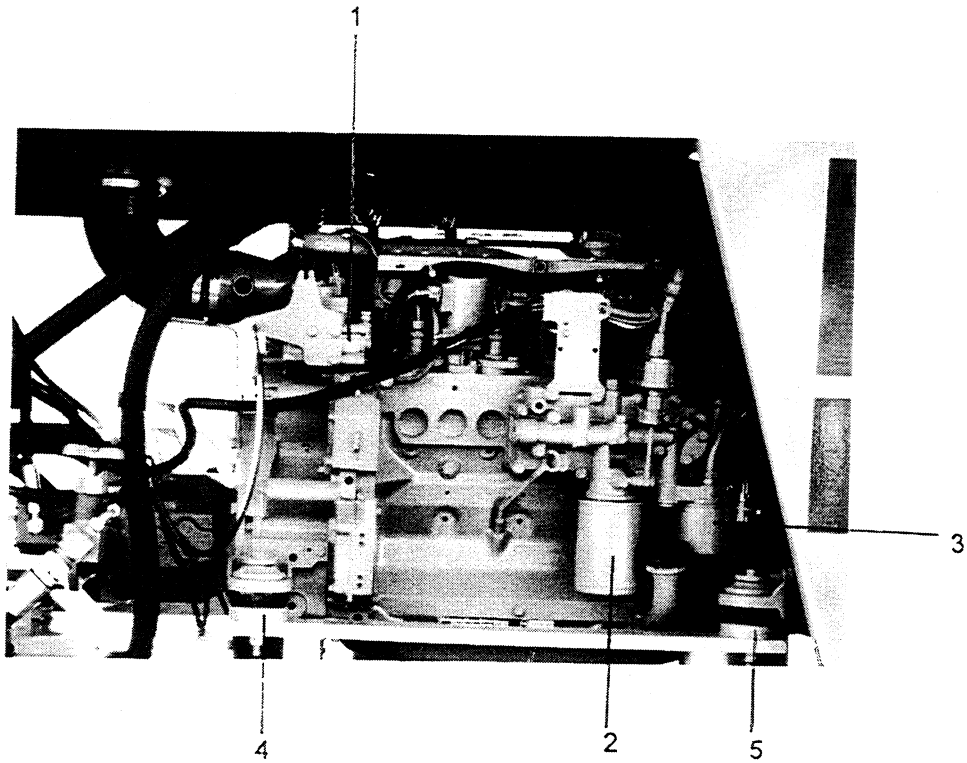

<u>ITEM</u>	<u>DESCRIPTION</u>	<u>PART#</u>	<u>QTY</u>
1	ENGINE	78190	1
2	OIL FILTER	74500	1
3	FUEL FILTER	72960	1
4	REAR MOTOR MOUNT	N/P/N	2
5	FRONT MOTOR MOUNT (NOT SHOWN)	N/P/N	2

HYDRAULIC VALVES

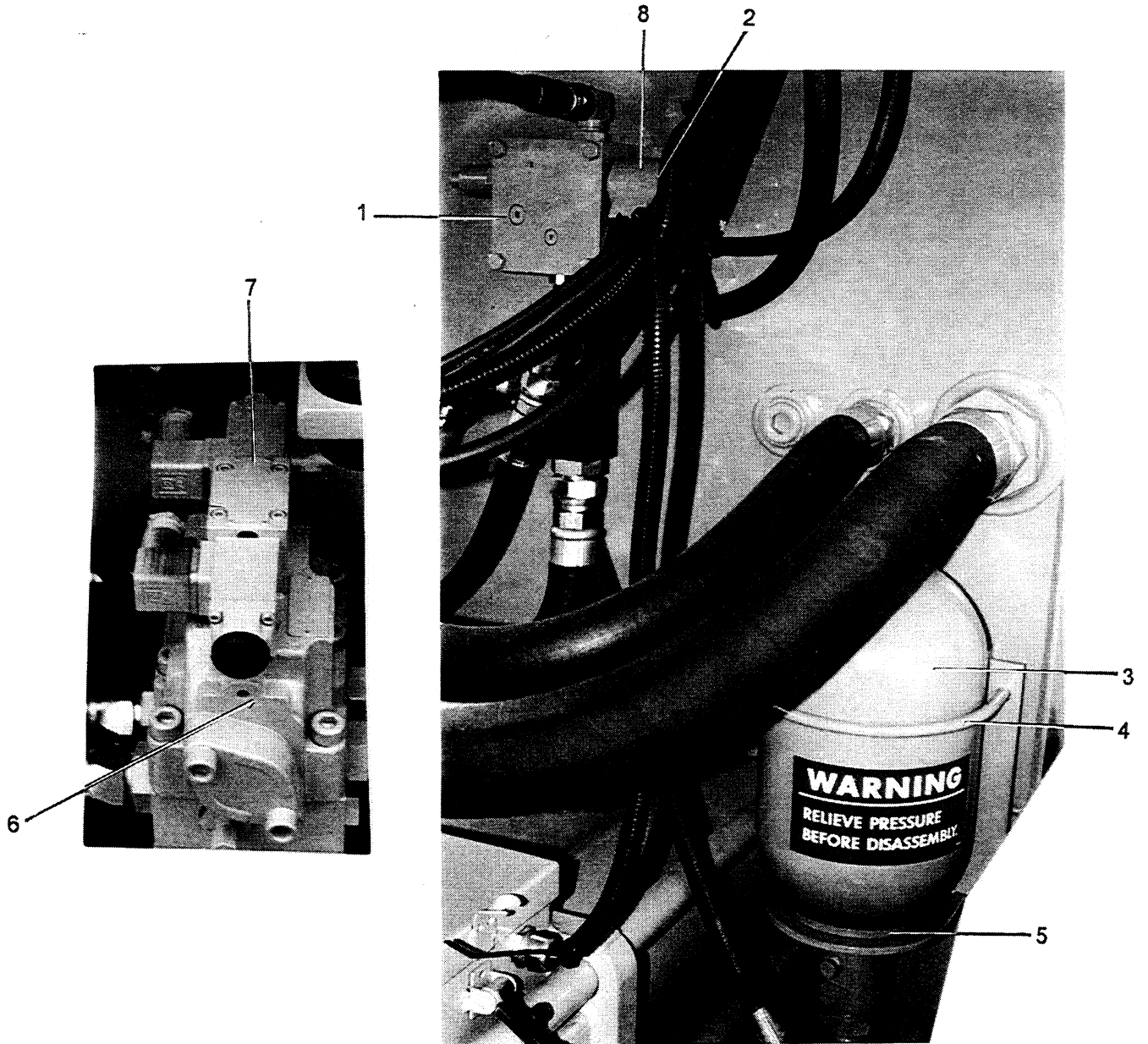

<u>ITEM</u>	<u>DESCRIPTION</u>	<u>PART #</u>	<u>QTY</u>
1	UNLOADER MANIFOLD BLOCK	72803	1
2	SOLENOID VALVE CARTRIDGE (not shown)	73143	1
3	ACCUMULATOR	74515	1
4	U-BOLT	70066	1
5	RUBBER WASHER	79539	1
6	MAIN CYCLING VALVE	74990	1
7	SOLENOID DOUBLE PILOT COMPLETE	74938	1
8	COIL--12VDC UNLOADER	73184	1

MAIN HYDRAULIC PUMP AREA

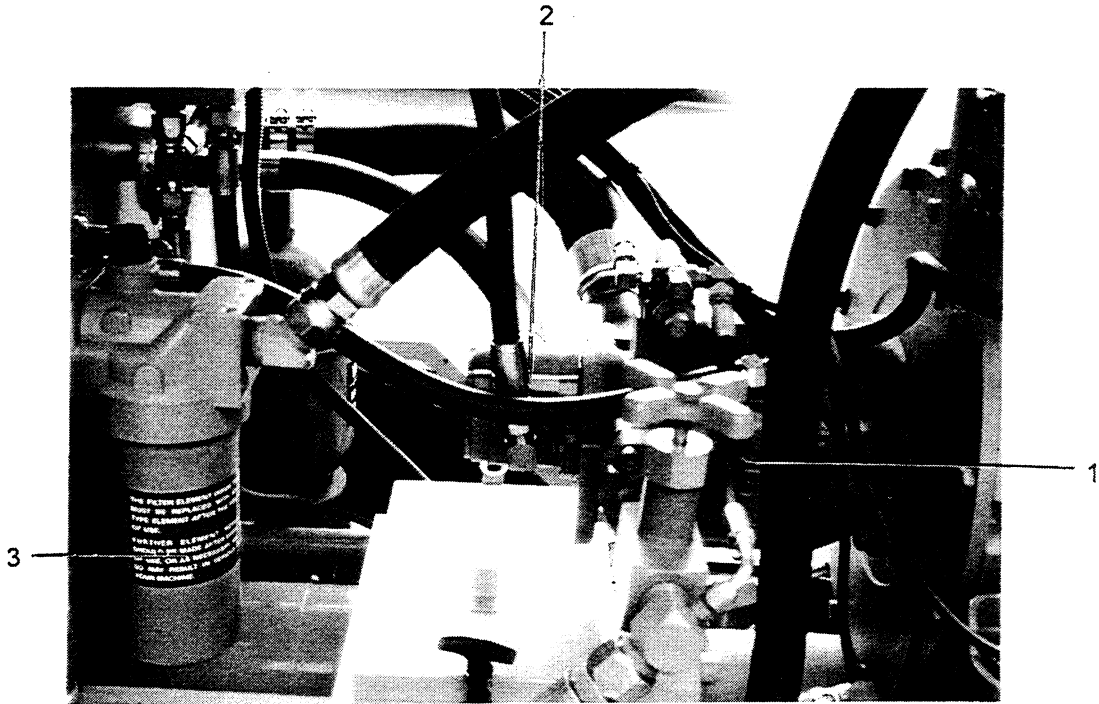

<u>ITEM</u>	<u>DESCRIPTION</u>	<u>PART#</u>	<u>QTY</u>
1	MAIN HYDRAULIC PUMP	79878	1
2	AUXILIARY PUMP (NOT SHOWN)	73156	1
3	FILTER ELEMENT	73303	1
4	BATTERY BOX (NOT SHOWN)	70054	1

FLUSHBOX AREA

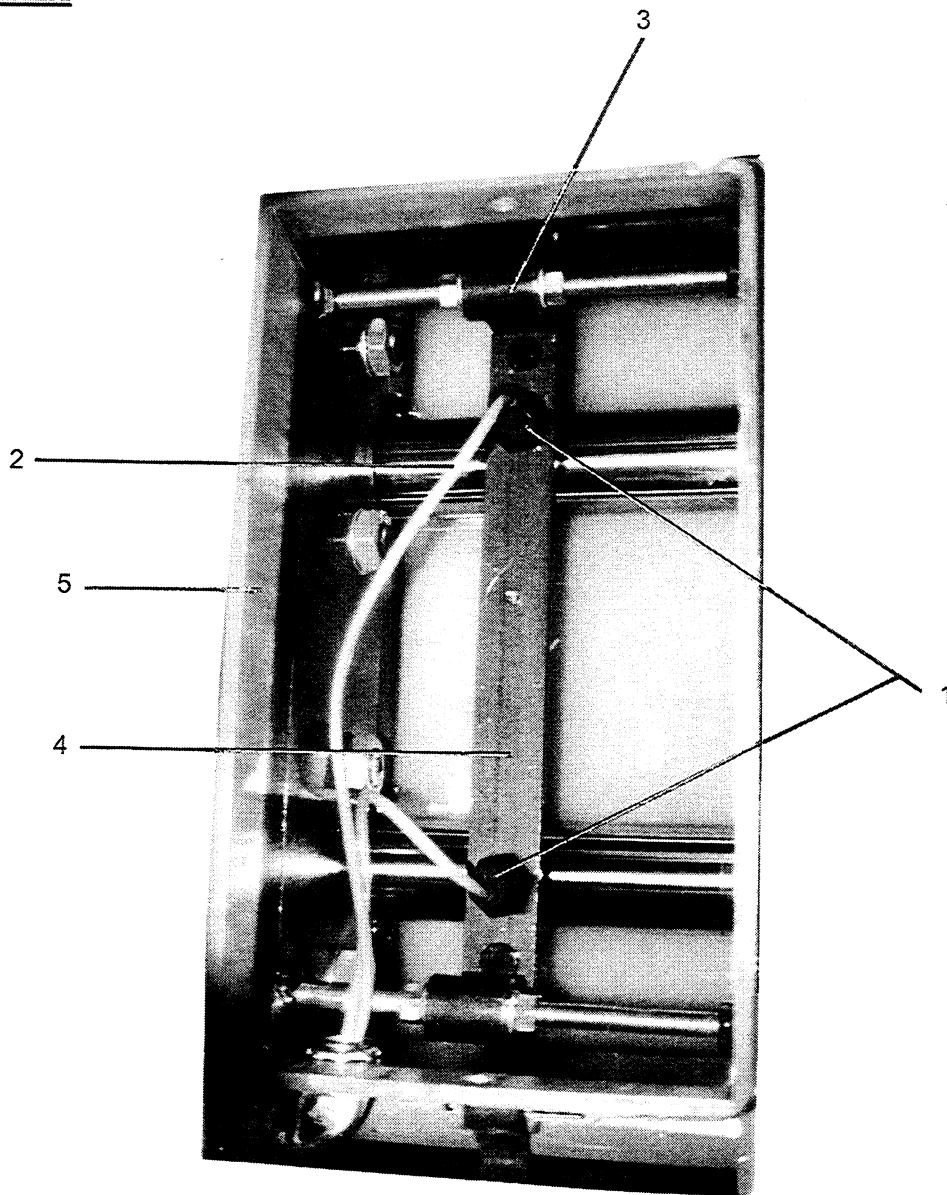

<u>ITEM</u>	<u>DESCRIPTION</u>	<u>PART#</u>	<u>QTY</u>
1	PROXIMITY SENSOR	77998	2
2	PROXIMITY SENSOR CABLE	77990	2
3	MOUNTING ANGLE	72940	1
4	MOUNTING BAR	72941	1
5	FLUSHBOX	73498	1

CONCRETE & HYDRAULIC CYLINDERS FOR 4040B, 4050B LIQUID COOLED

	<u>QTY</u>	
1) N/P/N - 3/4" X 3" BOLT	4	
2) 77852 - WEARPLATE	1	
3) N/P/N - 3/4" LOCKWASHER	4	
4) N/P/N - 3/4" COARSE NUT	4	
5) 70047 - ANTI-CHIP RING	2	
6) 70318 - CONCRETE CYLINDER ADAPTERS	2	
7) 73497 - CONCRETE CYLINDER (NEW STYLE)	2	
8) N/P/N - 3/8" X 1-1/2" FINE BOLT	8	
9) N/P/N - 3/8" INTERNAL LOCK WASHER	8	
10) 70057 - PISTON PLATE	2	
11) 70048 - PISTON CUP	2	
12) 74001 - O-RING	2	
13) 70076 - CONCRETE PISTON ADAPTER	2	
14) 77896 - PISTON COUPLER	2	
15) 73498 - FLUSH BOX WELDMENT	1	
16) N/P/N - 3/4" COARSE NUT	8	} INSIDE FLUSH BOX
17) N/P/N - 3/4" LOCKWASHER	8	
18) 77396 - 3/4" SEALING WASHER	8	
19) N/P/N - 3/4" X 6" COARSE SOCKET HEAD CAP SCREW	8	
20) 70986 - HYDRAULIC CYLINDER	2	
21) 73183 - END PLATE	1	
22) N/P/N - 1/2" LOCKWASHER	4	
23) N/P/N - 1/2" X 1" COARSE BOLT	4	
24) N/P/N - 1-1/4" FINE NUT	4	
25) 75882 - TIE ROD	4	

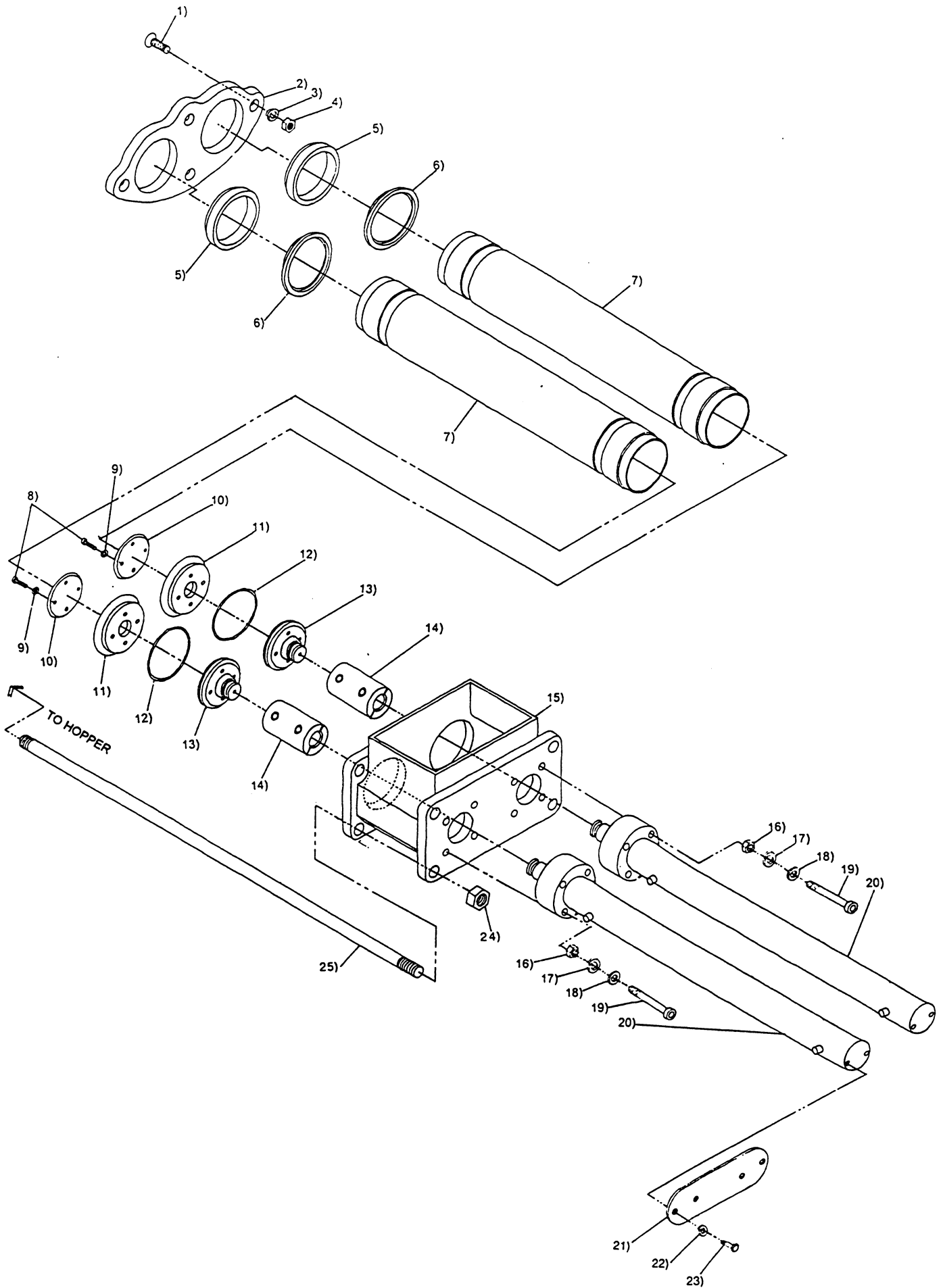

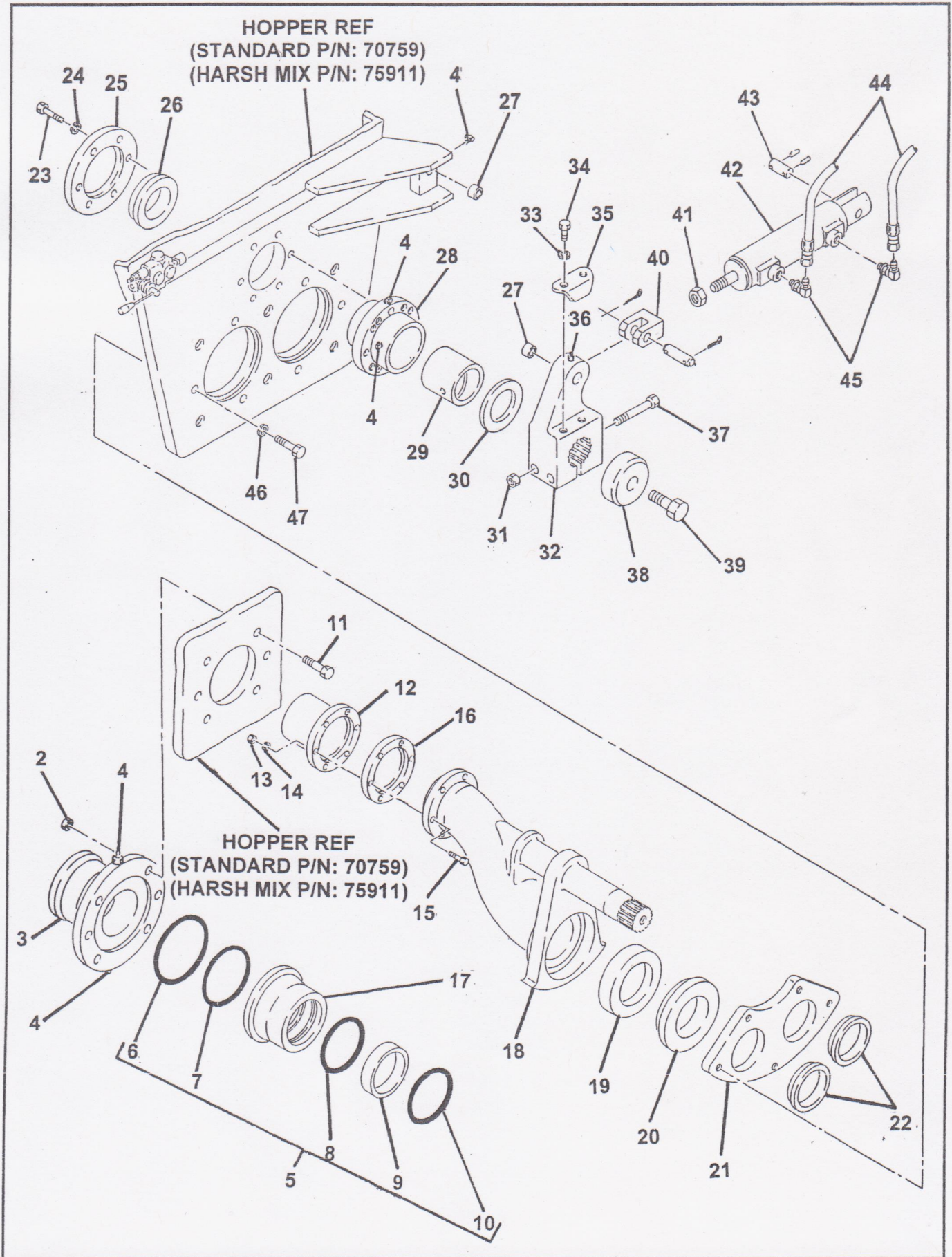

ITEM NO.	REED'S PARTS NO.	DESCRIPTION					QTY
		1	2	3	4	5	
-1	60-02	Assembly, Swing Valve (See Group 60, Figure 01 for NHA)					Ref
2		• Nut					6
3	72482	• Outlet, Machine 5"					1
4		• Fitting, Grease 90					5
5	79895	• Kit, Outlet Seal -					1
6	77761	• • O-Ring, Large					1
7	77762	• • O-Ring, Small					1
8	86504	• • Seal, Modified Outlet Thick					1
9	77763	• • Band, Guide					1
10	77765	• • Seal, Outlet Thick					1
11		• Bolt, Hex					6
12	70042	• Outlet, Chromed					1
13		• Nut, Nylock (attaching parts)					6
14		• Washer, Lock (attaching parts)					6
15		• Bolt, Hex (attaching parts)					6
16	73408	• Flange, Extension					A/R
17	72309	• Housing, Outlet Seal					1
18	77947	• Weldment, Standard Hopper Swing Tube					1
19	72311	• Ring, Thrust					1
20	72310	• Ring, Cutting					1
21	77852	• Plate, Wear					1
22	70047	• Ring, Anti Chip					2
23		• Bolt, Hex					4
24		• Washer, Lock					4
25	77398	• Retainer					1
26	75418	• Seal, Swing Tube					1
27	71011	• Race, Inner					2
28	77948	• Bearing, Flange					1
29	77949	• Bushing, Bronze					1
30	75506	• Washer, Thrust					1
31		• Nut					2
32	73476	• Crank, Bell					2
33		• Washer, Lock					2
34		• Bolt, Hex					1
35	73478	• Retainer, Bolt					1
36		• Fitting, Grease STR					1
37		• Bolt, Hex					2
38	77706	• Washer, Retainer					1
39	78060	• Bolt, Swing Tube					1
40	75260	• Kit, Clevis Pin					1

DASH (-) ITEM NOT ILLUSTRATED

ITEM NO.	REED'S PARTS NO.	DESCRIPTION					QTY
		1	2	3	4	5	
31		• Nut					2
32	73476	• Crank, Bell					2
33		• Washer, Lock					2
34		• Bolt, Hex					1
35	73478	• Retainer, Bolt					1
36		• Fitting, Grease STR					1
37		• Bolt, Hex					2
38	77706	• Washer, Retainer					1
39	78060	• Bolt, Swing Tube					1
40	75260	• Kit, Clevis Pin					1
41		• Nut, Hex					1
42	75087	• Sub-Assembly, Swing Ram Cylinder (See Group 60, Figure 03 for DET)					1
43	74207	• Clevis					1
44	79727	• Assembly, T50 Hose (See Schematic Section, Page 17 for REF)					1
45		• Fitting, 90					2
46		• Washer, Lock					6
47		• Bolt, Hex					6

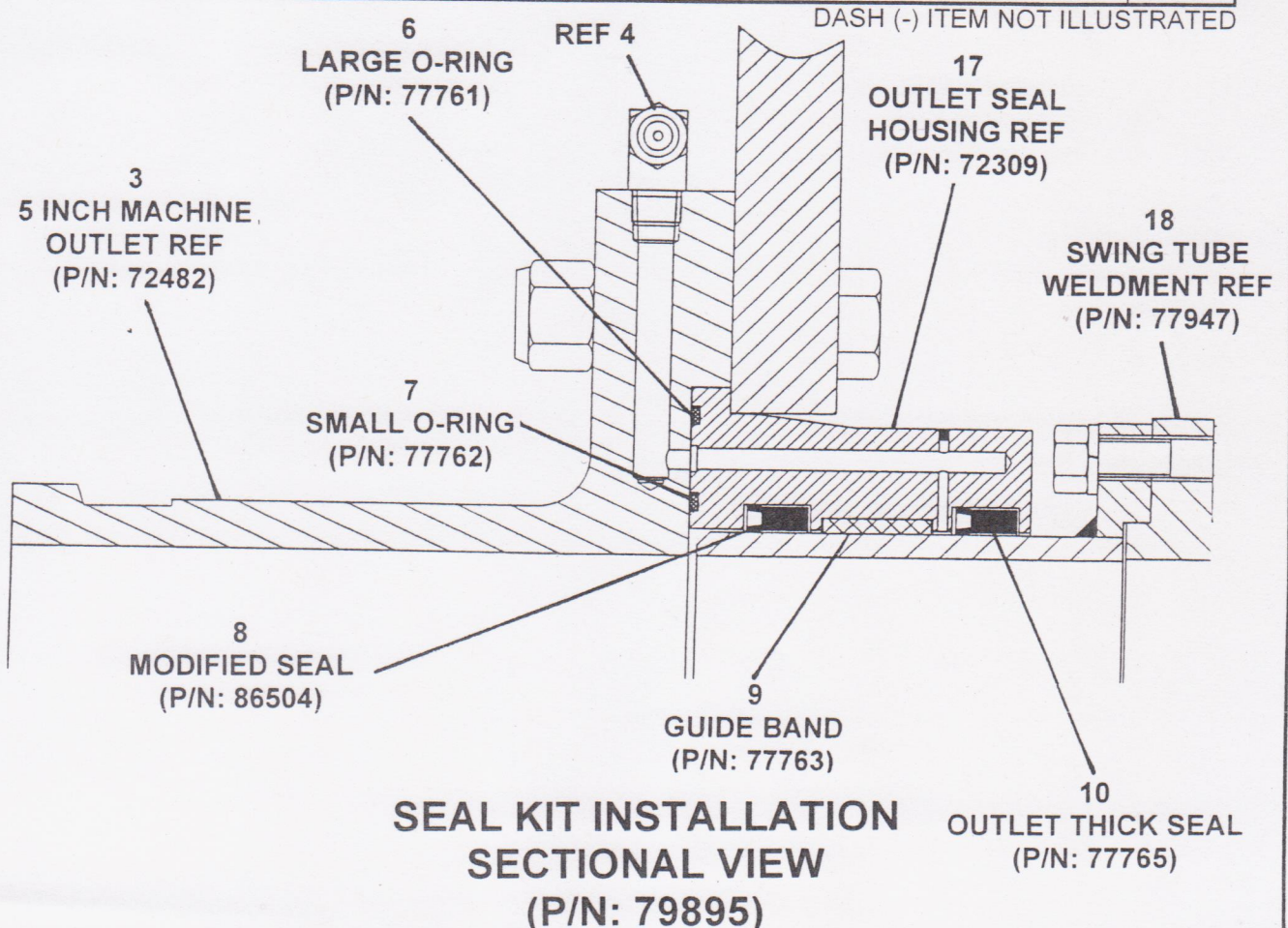

REAR HYDRAULIC TANK

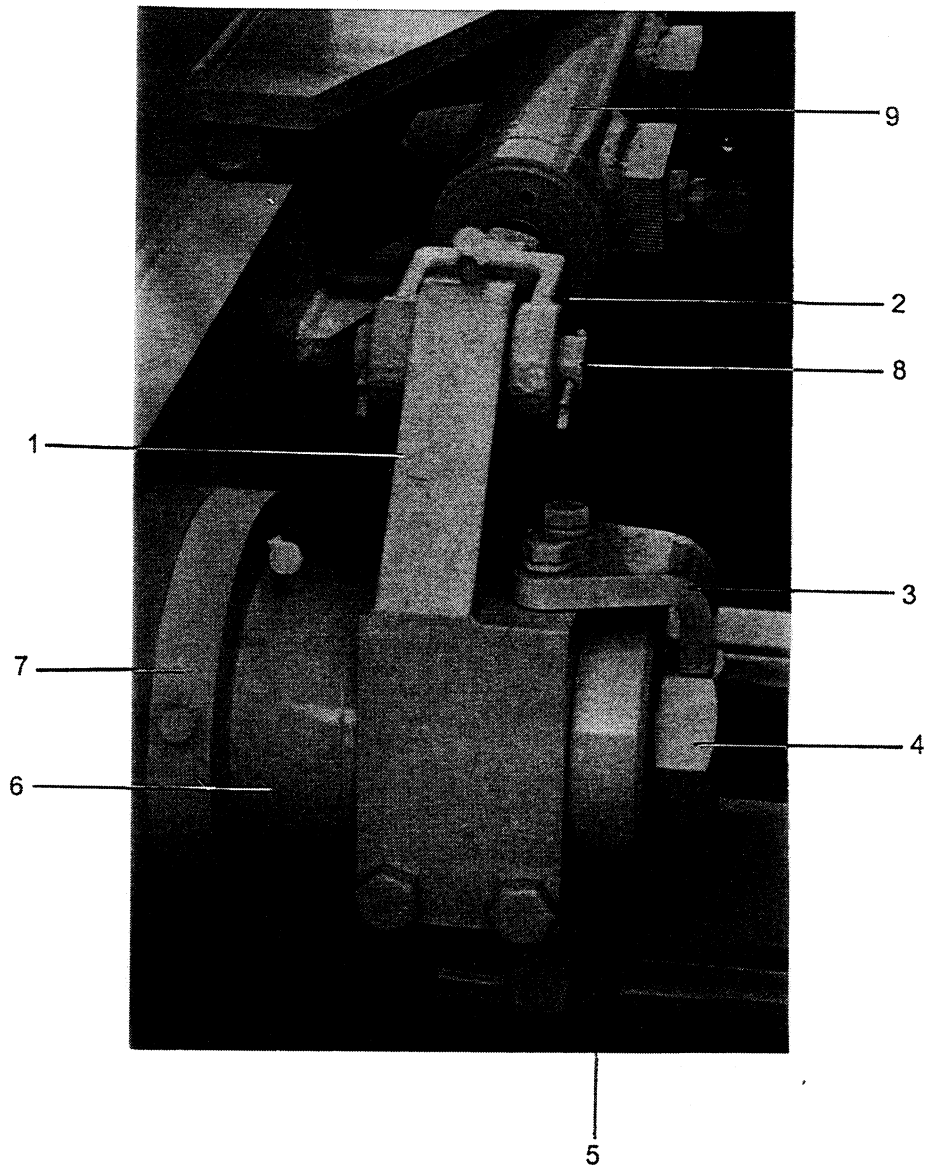

<u>ITEM</u>	<u>DESCRIPTION</u>	<u>PART#</u>	<u>QTY</u>
1	BELL CRANK	73476	1
2	CLEVIS WITH PIN 1"	75260	1
3	BOLT RETAINER SWING TUBE	73478	1
4	BOLT SWING TUBE	78060	1
5	WASHER SWING TUBE SHAFT END	77706	1
6	BRONZE BUSHING (INSIDE FLANGE BEARING)	77949	1
7	FLANGE BEARING	77948	1
8	PIN ONLY	75338	1
9	SWING TUBE HYDRAULIC CYLINDER BEHIND CLEVIS	75087	1

AGITATOR ASSEMBLY

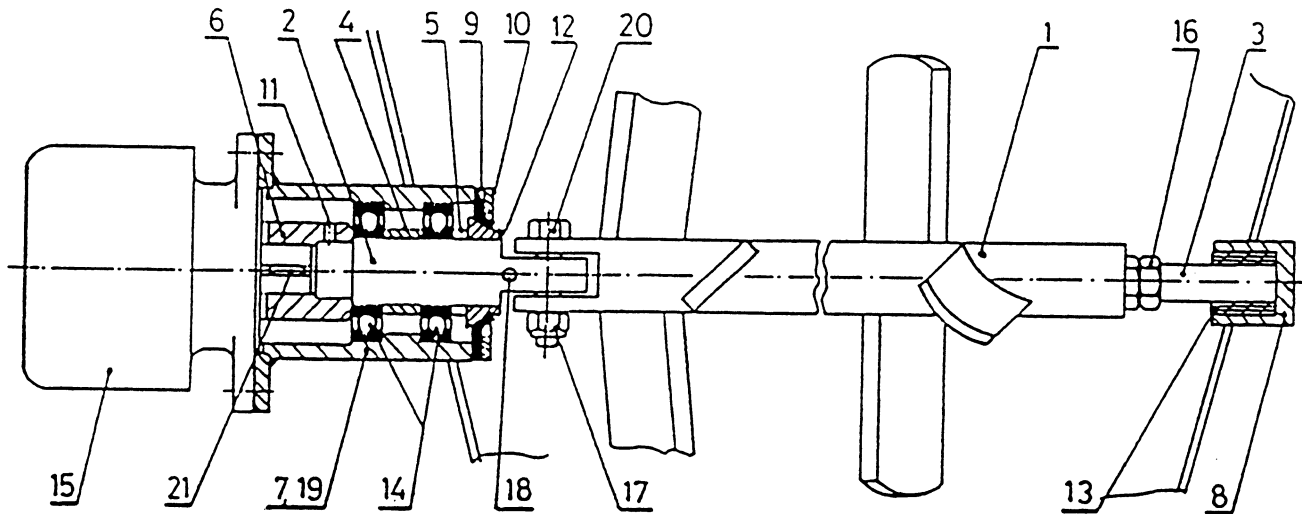

<u>ITEM</u>	<u>DESCRIPTION</u>	<u>PART #</u>	<u>QTY</u>
1	AGITATOR SHAFT WITH PADDLES	70202	1
2	SHAFT	70224	1
3	IDLER SHAFT	70214	1
4	SPACER--LONG	70215	1
5	SPACER--SHORT	70216	1
6	MOTOR COUPLING	70225	1
7	BEARING HOUSING	70223	1
8	IDLER BEARING HOUSING	70210	1
9	SEAL	70212	1
10	SEAL FLANGE	70211	1
11	SET SCREW	80374	1
12	WEAR RING	71018	1
13	IDLER BEARING	70219	1
14	BEARING SINGLE ROW BALL	71019	1
15	HYDRAULIC MOTOR	74529	1
16	HEX NUT M 20	80030	1
17	HEX NUT SELF-LOCKING 1/2-13	80019	1
18	SPRING PIN 3/16 X 1-3/4	80298	1
19	GREASE FITTING	80516	1
20	HEX HEAD CAP SCREW 1/2-13 X 2-1/2	80156	1
21	KEY	30216	1