



**TRAILER MOUNTED PUMP MODEL C50HP
DRIVE CYLINDER CIRCUIT
HYDRAULIC COMPONENTS**

SCMTC

PAGE 01

Code	Description	Part No.	Qty
DRIVE CYLINDER CIRCUIT			
P1	Main Pump - 100 cc	75864	1
PCP1	Pressure Control Pilot Valve	77040	1
CYL1	Hydraulic Drive Cylinder-3.50x2.00x41	86222	2
C1	Check Valve	78961	4
C2			
C3	Check Valve	77282	1
HOS1	Hot Oil Shuttle Valve	72980	1
RV1	Pressure Limiter Valve	800074	2
G1	Pressure Gauge - 6000 psi	74562	1
OC1	Oil Cooler	86078	1
RF1	Return Filter	85282	1
	Return Filter Element	85283	1
G3	Pressure Gauge - Return	85575	1
SS1	Magnetic Suction Strainer	79247	1
S-TUBE CIRCUIT			
P2	Tandem Gear Pump - 12/10cc	73156	1
	Gear Pump -5.5cc	87153	1
CYL2	S-Tube Shift Cylinder-2.50x5.75	86220	2
MAN2	Manifold - S-Tube Circuit(#86821 Manifold Only)	85249 ASSY	1
SV2	Solenoid Valve - S-Tube Circuit	85693	1
SV2-1	Solenoid Valve - Main	85694	1
SV2-2	Solenoid Valve - Pilot	85695	1
	Coil for SV2-2	85692	2
SV3	Solenoid Valve Cartridge	87246	1
	Coil for SV3	87247	1
SV4	Solenoid Valve Cartridge	87248	1
	Coil for SV4	87249	1
RV2	Relief Valve Cartridge	85703	1
UV1	Unloader Valve Cartridge	85704	1
BV1	Ball Valve	85705	1
ACC1	Accumulator	74515	1
G2	Pressure Gauge - 3000 psi	70366	1
SS2	Magnetic Suction Strainer	79247	1
AGITATOR / OUTRIGGER CIRCUIT			
DV3	Directional Valve - Agitator / Outrigger	74471	1
RV3	Relief Valve Cartridge	85706	1
SV5	Solenoid Valve	87154	1
	Coil for SV5	87155	1
M1	Agitator Motor - 747cc (Standard Hopper)	85811	1
CYL3	Hydraulic Outrigger Cylinder-2.00x12.00	86574	2
SS3	Magnetic Suction Strainer	79247	1

REVISION:



TRAILER MOUNTED PUMP MODEL C50HP
DUAL SHIFT SWING TUBE CIRCUIT
HYDRAULIC SCHEMATIC

SCMTC

PAGE 03

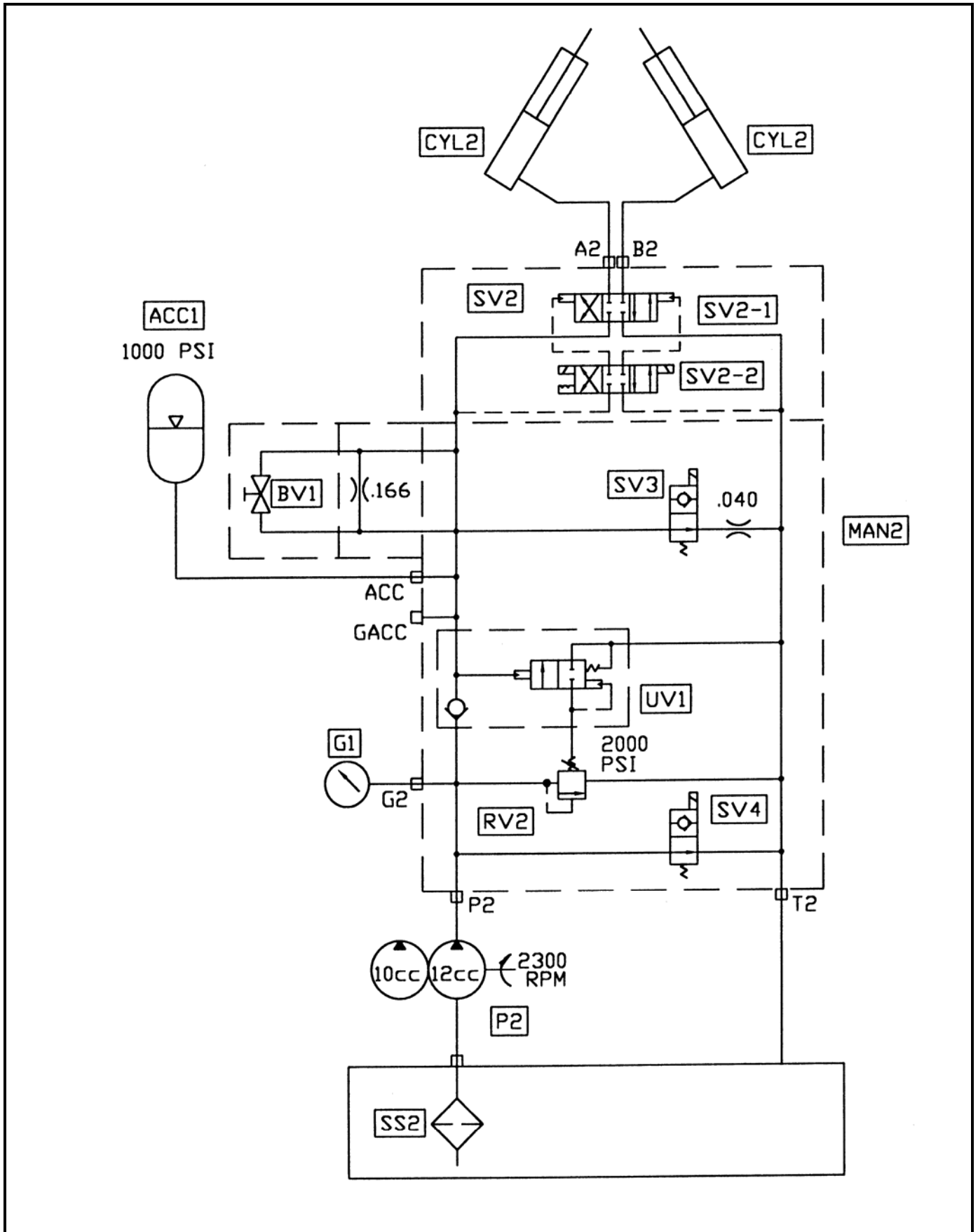

REVISION:



TRAILER MOUNTED PUMP MODEL C50HP
AGITATOR / OUTRIGGER OPTION CIRCUIT
HYDRAULIC SCHEMATIC

SCMTC

PAGE 04

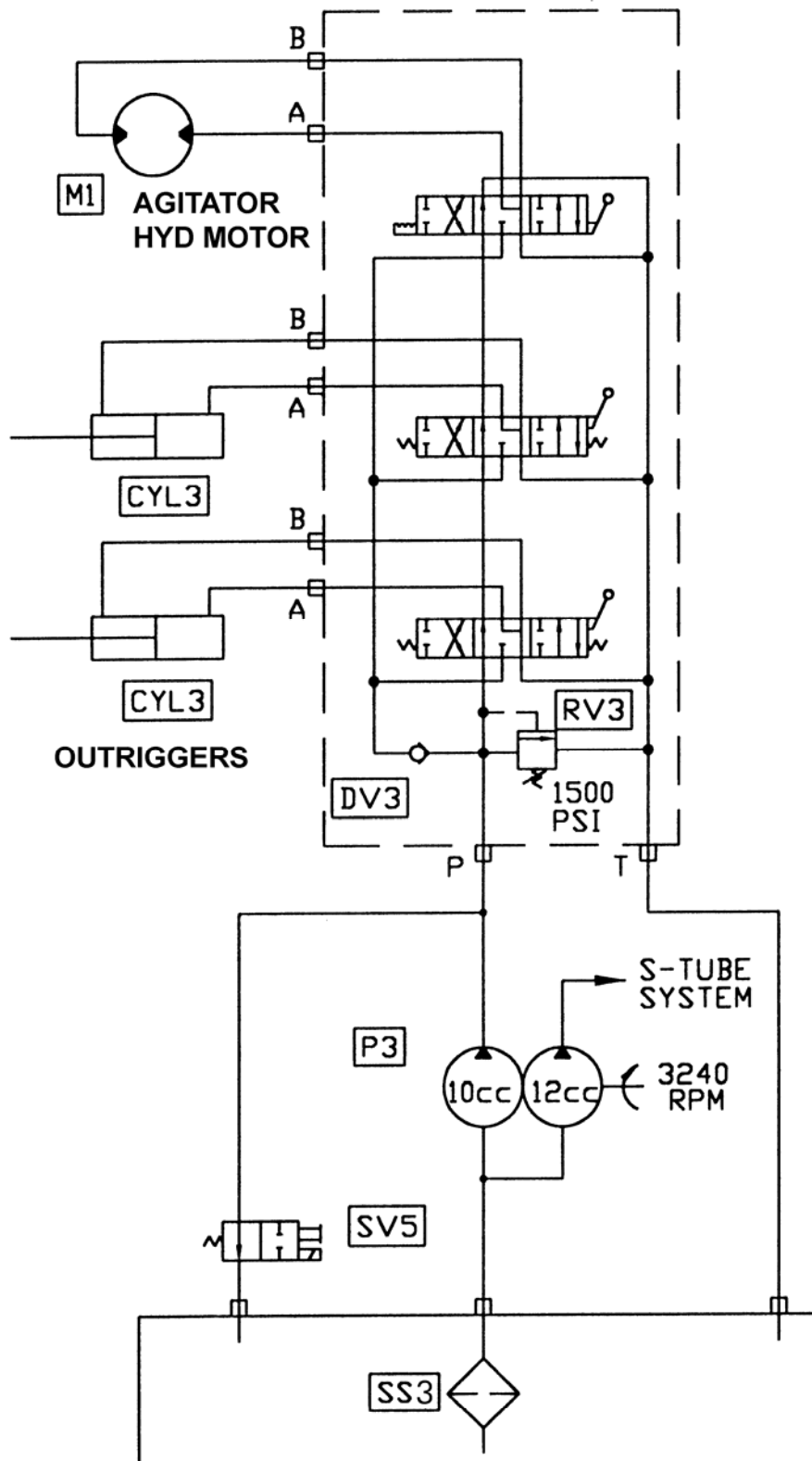

REVISION:



**TRAILER MOUNTED PUMP MODEL C50HP
ELECTRICAL COMPONENTS (1 OF 2)**

Code	Description	Part No.	Qty	Location
SWITCHES				
1S1	Key Switch	71154	1	Control Panel
2S2	Toggle Switch, Horn	85347	1	Control Panel
2S10	Toggle Switch, Cyl Chg-Over Fast/Slow	72963	1	Control Panel
3S3	Toggle Switch, Local/Remote	78563	1	Control Panel
3S4	Toggle Switch, Pump On/Reverse	72003	1	Control Panel
3S5	Toggle Switch, Test A/B	85346	1	Control Panel
3S6	E-Stop Switch	85342	1	Control Panel
	Contact Block, 1NC for 3S6	85343	1	Control Panel
3S7	E-Stop Switch	85342	1	Remote Control
	Contact Block, 1NC for 3S7	85343	1	Remote Control
3S8	Toggle Switch, Horn	85347	1	Remote Control
3S9	Toggle Switch, Pump On/Reverse	72003	1	Remote Control
RELAYS				
1K1	Relay, Engine Start	85348	1	Engine
LIGHTS				
1L1	Light, Green, Control On	85355	1	Control Panel
1L2	Light, Red, Oil Temperature	73775	1	Control Panel
1L4	Light, Red, Oil Pressure	73775	1	Control Panel
1L5	Light, Red, Alternator	73775	1	Control Panel
	Bulb for 1L2, 1L3, 1L4, 1L5	72022	4	Control Panel
2L6	Bulb, E-Stop	85344	1	Control Panel
2L7	Light, Green, Local	85355	1	Control Panel
3L8	Light, Yellow, Remote	85356	1	Control Panel
3L9	Light, Green, Pump On	85355	1	Control Panel
3L10	Light, Green, Reverse	85355	1	Control Panel
3L11	Bulb, E-Stop	85344	1	Remote Control
3L12	Light, Green, Pump On	85355	1	Remote Control
GAUGES				
1G1	Hour Meter	74240	1	Control Panel
1G2	Tachometer	78687	1	Control Panel



**TRAILER MOUNTED PUMP MODEL C50HP
ELECTRICAL COMPONENTS (2 OF 2)**

Code	Description	Part No.	Qty	Location
FUSES				
1F1	Fuse, 25A	800447	1	Control Panel
1F2	Fuse, 20A	800448	1	Control Panel
1F3	Fuse, 5A	90392	1	Control Panel
2F4	Fuse, 10A	800449	1	Control Panel
2F5	Fuse, 10A	800449	1	Control Panel
2F6	Fuse, 5A	90392	1	Control Panel
2F8	Fuse, 10A	800449	1	Control Panel
	Fuse Block, 8 Way	85354	1	Control Panel
SOLENOID VALVE COILS				
1Y1	Coil, Fuel Solenoid	Deutz	1	Engine
1Y2	Coil, Accumulator Bypass	85700	1	S-Tube Manifold
1Y3	Coil, S-Tube Bypass	85702	1	S-Tube Manifold
1Y4	Coil, Agitator Bypass	73184	1	Hyd. Tank
2Y5	Coil, EDC	85692	1	Main Pump
2Y7	Coil, S-Tube Shift "A"	85692	1	Pump Manifold
2Y8	Coil, S-Tube Shift "B"	85692	1	Pump Manifold
	Plugs for 1Y2, 1Y3, 1Y4, 2Y7, 2Y8	74597	5	Manifolds
MISCELLANEOUS				
2BB1	Black Box, Pump Control	85334	1	Control Box
2BB2	Black Box, E-Stop Logic	85596	1	Control Box
2P1	Proximity Switch, Cyl "B"	77998	1	Water Box
2P2	Proximity Switch, Cyl "A"	77998	1	Water Box
2H1	Horn	800347	1	Control Box
3R1	Resistor, 100 Ohm	72777	1	Remote Control
3R2	Resistor, 100 Ohm	72777	1	Control Box
3R3	Potentiometer, 100 Ohm	77642	1	Control Box
3R4	Potentiometer, 100 Ohm	77642	1	Remote Control
CONNECTORS				
X1	Connector Insert, 24 Pin, Female	78696	1	Control Box
X1	Connector Base	78697	1	Control Box
X1	Connector Insert, 24 Pin, Male	78695	1	Harness
X1	Connector Hood	800424	1	Harness
X2	Terminal Block	72820	8	Control Box
X3	Connector Insert, 10 Pin, Female	79963	1	Control Box
X3	Connector Base	79965	1	Control Box
X3	Connector Insert, 10 Pin, Male	79964	1	Remote Control
X3	Connector Hood	79966	1	Remote Control
X4	Connector, Engine	72779	1	Harness
X6	Connector, Pump	72906	1	Harness



TRAILER MOUNTED PUMP MODEL C50HP ELECTRICAL SCHEMATIC (2 OF 3)

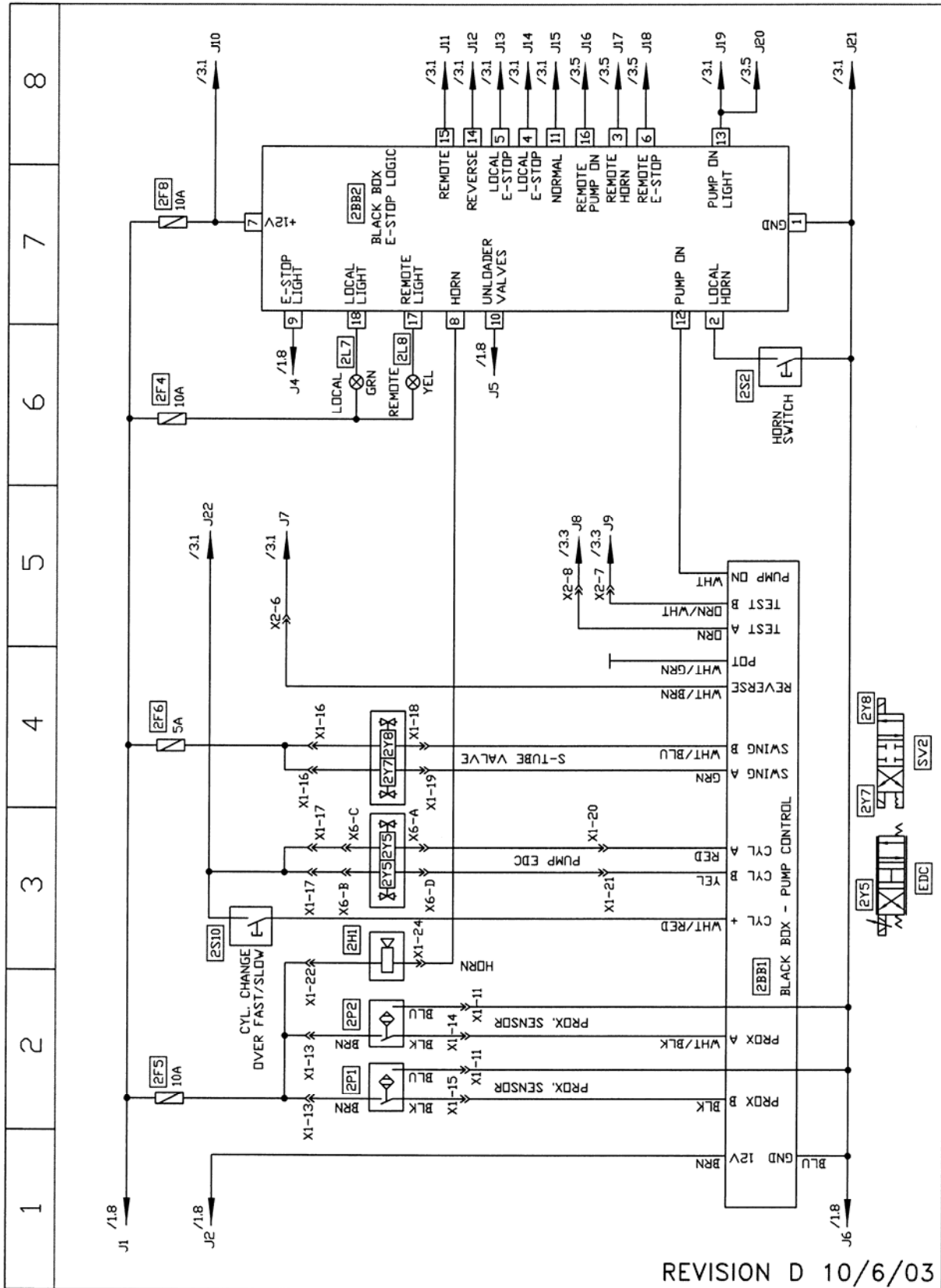

REVISION D 10/6/03

REVISION:



TRAILER MOUNTED PUMP MODEL C50HP ELECTRICAL SCHEMATIC (3 OF 3)

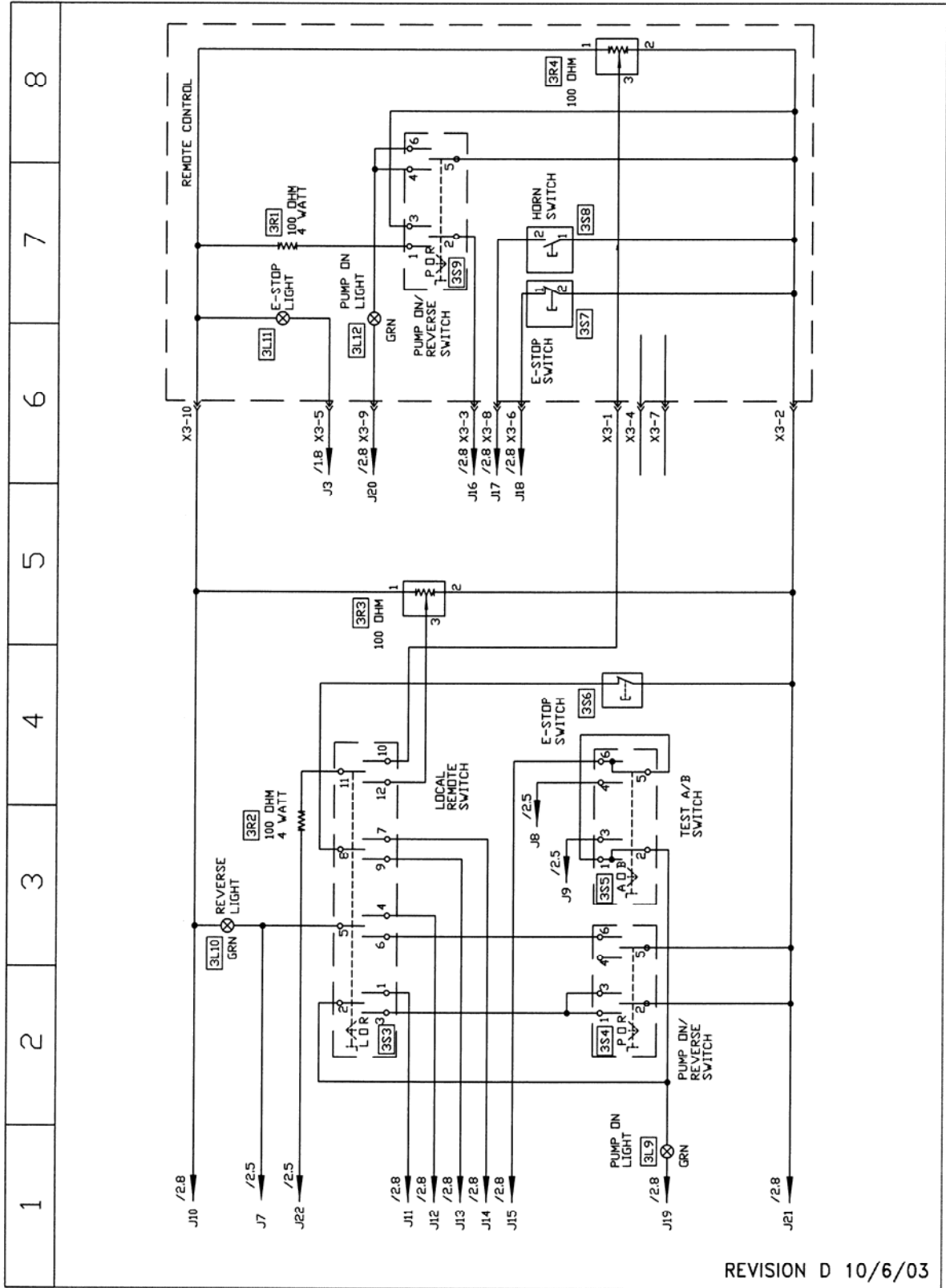

REVISION D 10/6/03

REVISION:



TRAILER MOUNTED PUMP MODEL C50HP CONTROL BOX ELECTRICAL COMPONENTS

SCMTC

PAGE 10

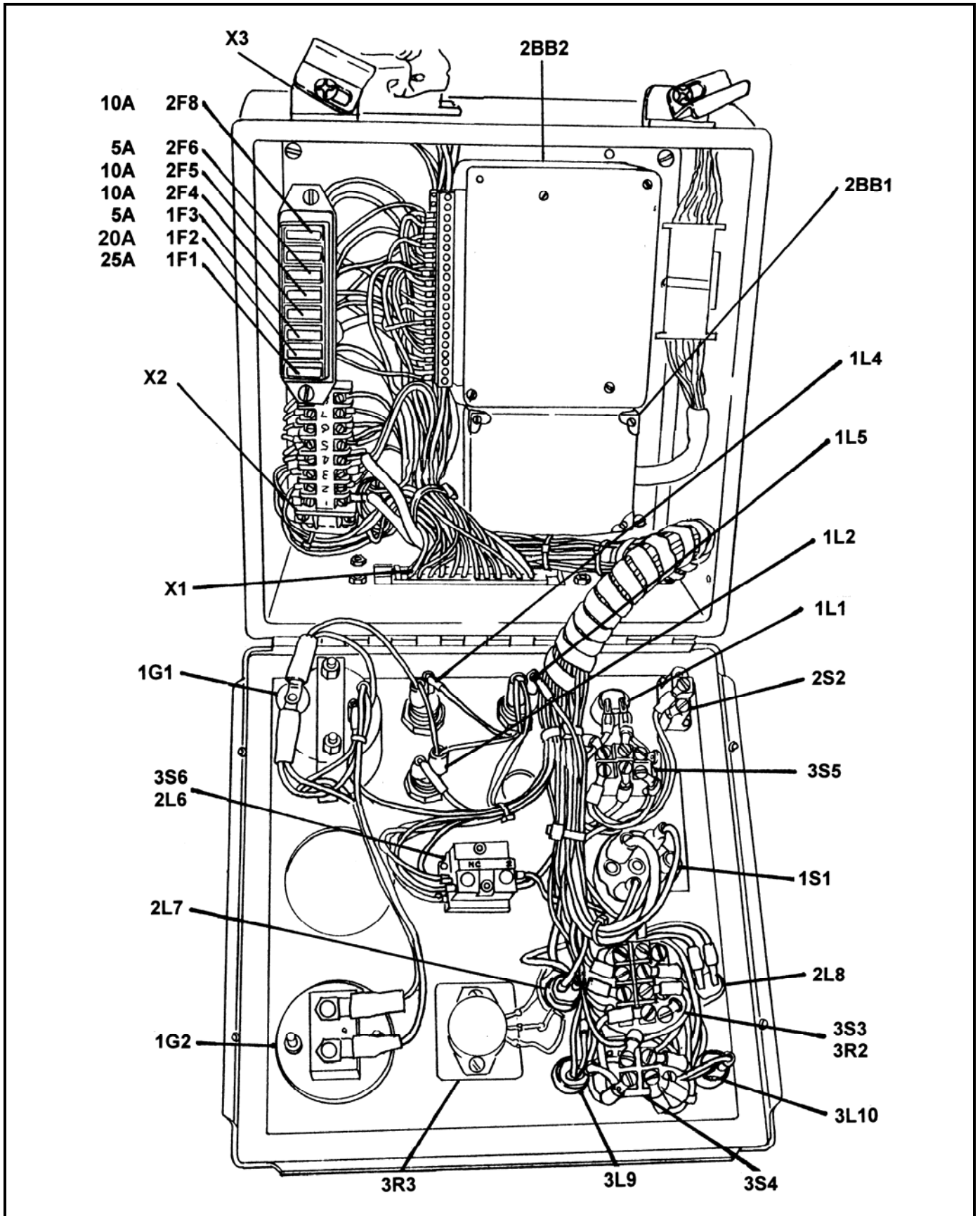

REVISION:



TRAILER MOUNTED PUMP MODEL *C50HP*
WIRE PROCEDURE
FOR POTENTIOMETER

LOOKING FROM THE BACK OF THE COMPONENT

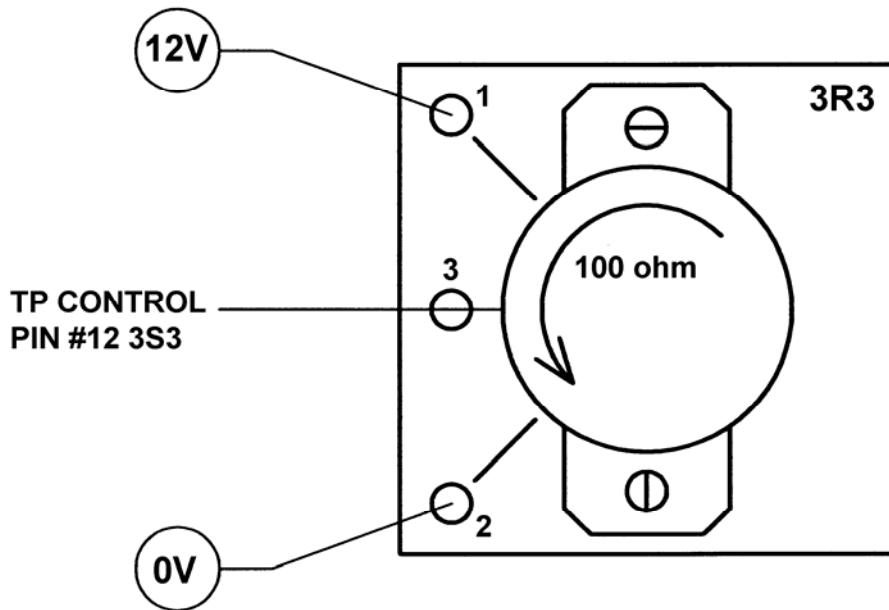

WIRE PROCEDURE FOR POTENTIOMETER
USED ON C-SERIES CONTROL BOXES



TRAILER MOUNTED PUMP MODEL C50HP
CABLE REMOTE CONTROL ASSEMBLY

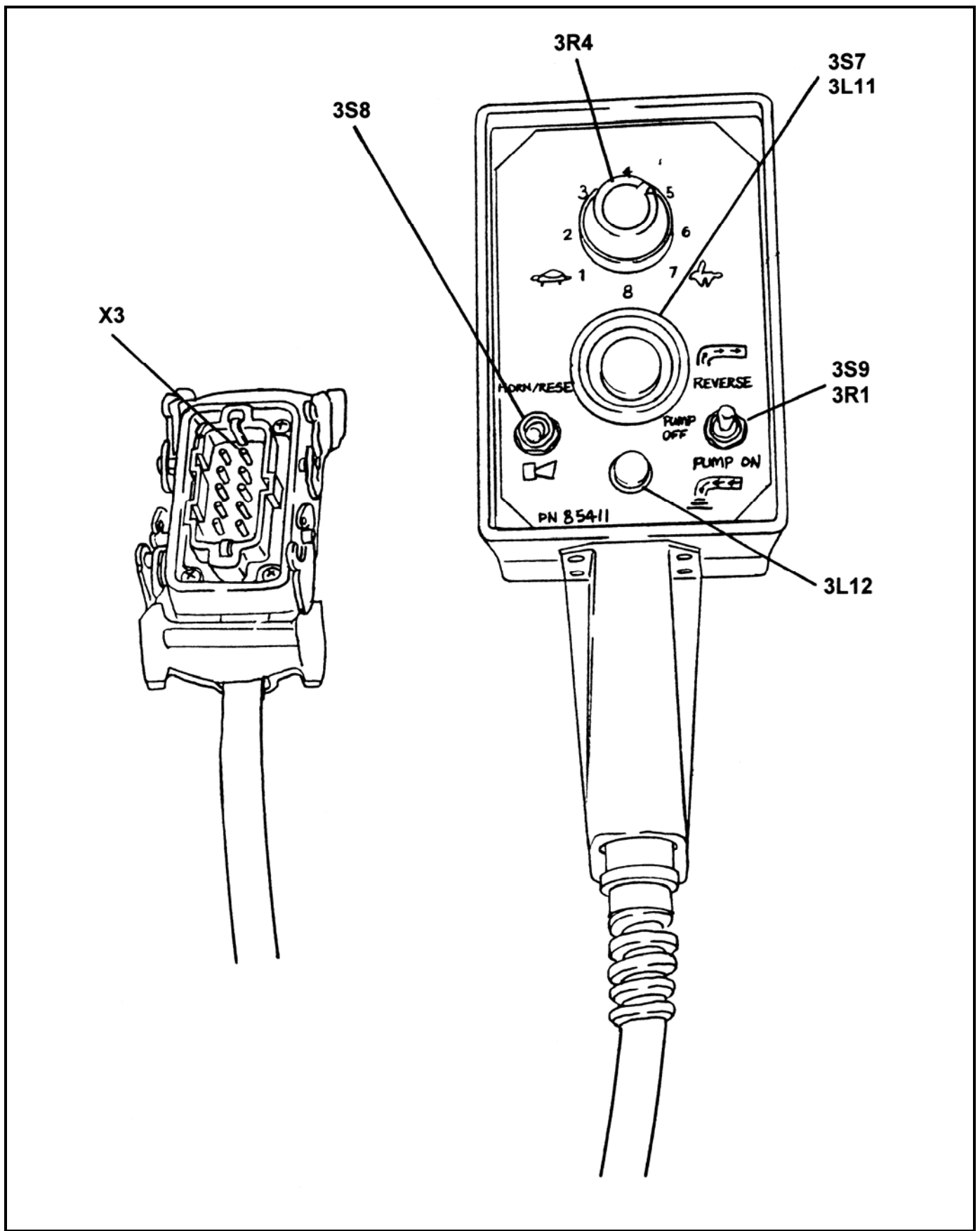

REVISION:



TRAILER MOUNTED PUMP MODEL C50HP WIRING HARNESS

SCMTC

PAGE 13

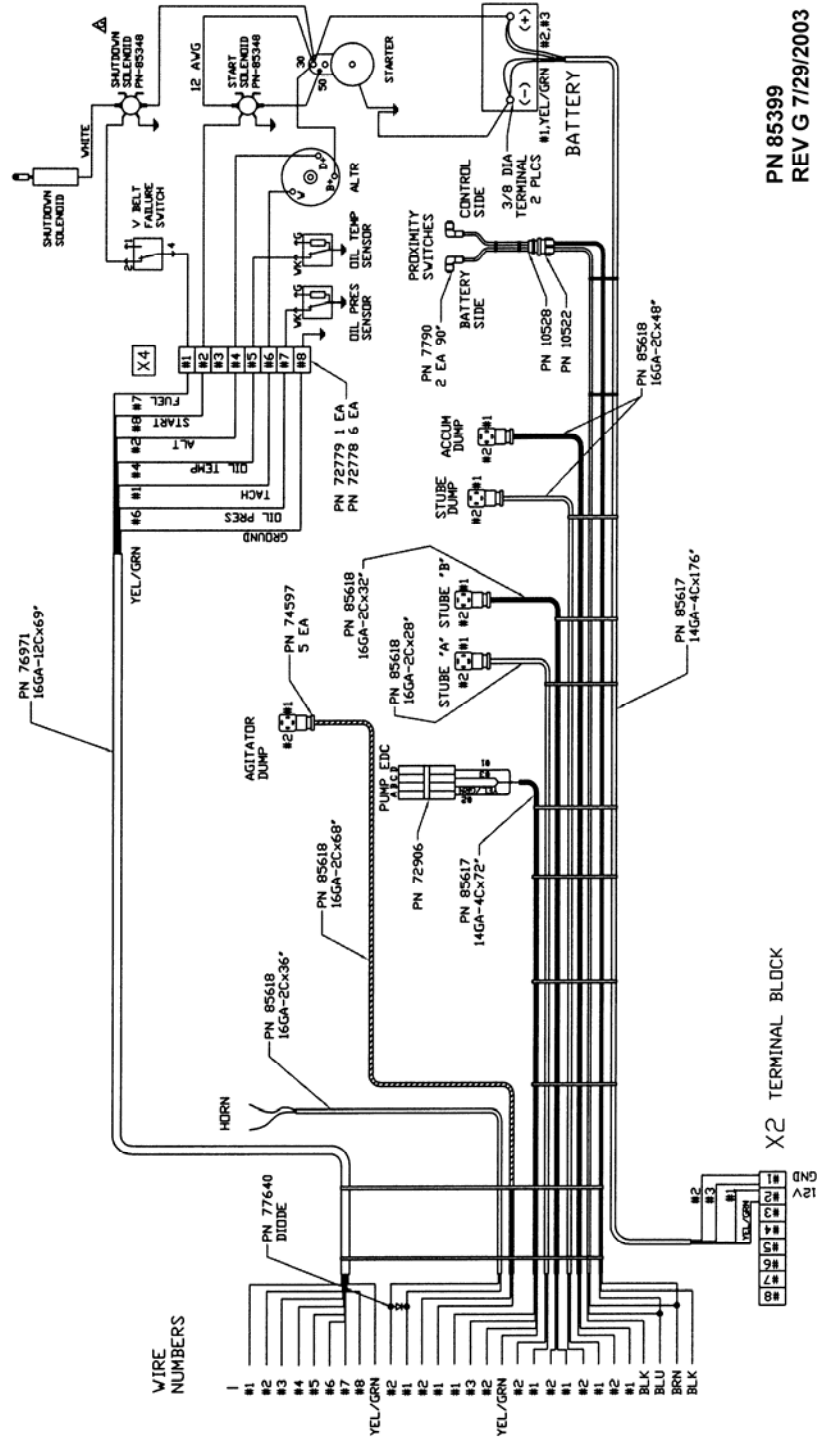

PN 85399
REV G 7/29/2003

- PN 800424 HOOD
PN 78695 INSERT
PN 801479 CONNECTOR
- 24 PIN PLUG X1
- | | |
|------|---------------|
| #1 | TACHMETER |
| #2 | ALTERNATOR |
| #3 | OIL TEMP |
| #4 | OIL PRESSURE |
| #5 | FUEL SOLENOID |
| #6 | ENG. START |
| #7 | GROUND |
| #8 | GROUND |
| #9 | HORN |
| #10 | HORN |
| #11 | HORN |
| #12 | HORN |
| #13 | HORN |
| #14 | HORN |
| #15 | HORN |
| #16 | HORN |
| #17 | HORN |
| #18 | HORN |
| #19 | HORN |
| #20 | HORN |
| #21 | HORN |
| #22 | HORN |
| #23 | HORN |
| #24 | HORN |
| #25 | HORN |
| #26 | HORN |
| #27 | HORN |
| #28 | HORN |
| #29 | HORN |
| #30 | HORN |
| #31 | HORN |
| #32 | HORN |
| #33 | HORN |
| #34 | HORN |
| #35 | HORN |
| #36 | HORN |
| #37 | HORN |
| #38 | HORN |
| #39 | HORN |
| #40 | HORN |
| #41 | HORN |
| #42 | HORN |
| #43 | HORN |
| #44 | HORN |
| #45 | HORN |
| #46 | HORN |
| #47 | HORN |
| #48 | HORN |
| #49 | HORN |
| #50 | HORN |
| #51 | HORN |
| #52 | HORN |
| #53 | HORN |
| #54 | HORN |
| #55 | HORN |
| #56 | HORN |
| #57 | HORN |
| #58 | HORN |
| #59 | HORN |
| #60 | HORN |
| #61 | HORN |
| #62 | HORN |
| #63 | HORN |
| #64 | HORN |
| #65 | HORN |
| #66 | HORN |
| #67 | HORN |
| #68 | HORN |
| #69 | HORN |
| #70 | HORN |
| #71 | HORN |
| #72 | HORN |
| #73 | HORN |
| #74 | HORN |
| #75 | HORN |
| #76 | HORN |
| #77 | HORN |
| #78 | HORN |
| #79 | HORN |
| #80 | HORN |
| #81 | HORN |
| #82 | HORN |
| #83 | HORN |
| #84 | HORN |
| #85 | HORN |
| #86 | HORN |
| #87 | HORN |
| #88 | HORN |
| #89 | HORN |
| #90 | HORN |
| #91 | HORN |
| #92 | HORN |
| #93 | HORN |
| #94 | HORN |
| #95 | HORN |
| #96 | HORN |
| #97 | HORN |
| #98 | HORN |
| #99 | HORN |
| #100 | HORN |

REVISION:



TRAILER MOUNTED PUMP MODEL C50HP
 RADIO REMOTE CONTROL OPTION
 WIRING DIAGRAM

SCMTC

PAGE 15

X3 PIN	FUNCTION
1	
2	GROUND
3	PUMP ON/REV.
4	
5	
6	'E' STOP
7	
8	HORN
9	
10	+12 vdc

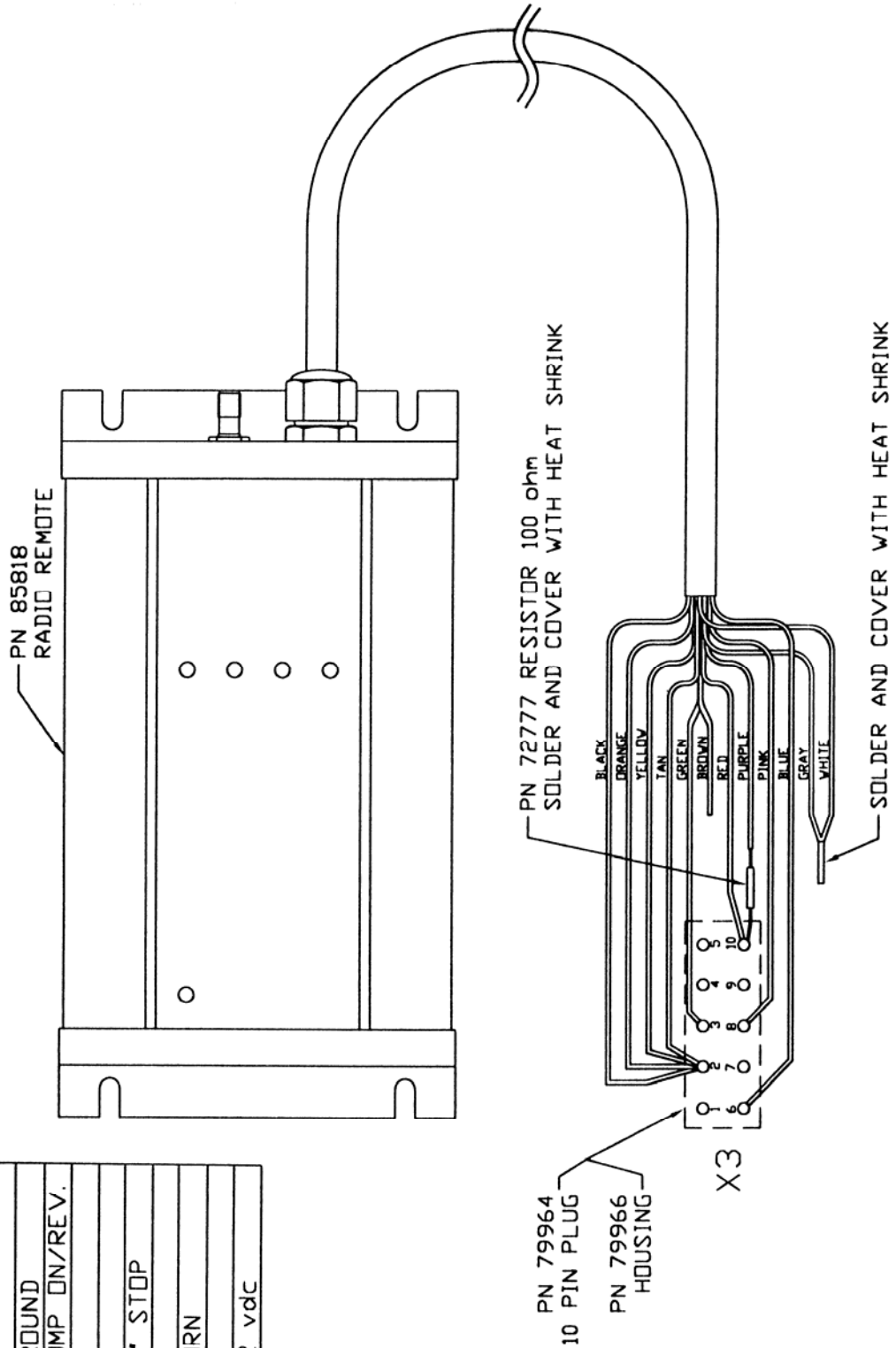

REVISION:



TRAILER MOUNTED PUMP MODEL C50HP HOPPER VIBRATOR ELECTRICAL SCHEMATIC

SCMTC

PAGE 16

1	2	3	4	5	6	7	8
---	---	---	---	---	---	---	---

CODE	PART NO.	DESCRIPTION
M1	71429	VIBRATOR
K1	W-105618	RELAY
S1	72965	TOGGLE SWITCH
F1	85839	FUSE - 30A
D1	776404	DIODE
X1	85899	RECEPTACLE
X1	85898	CABLE V/ PLUG

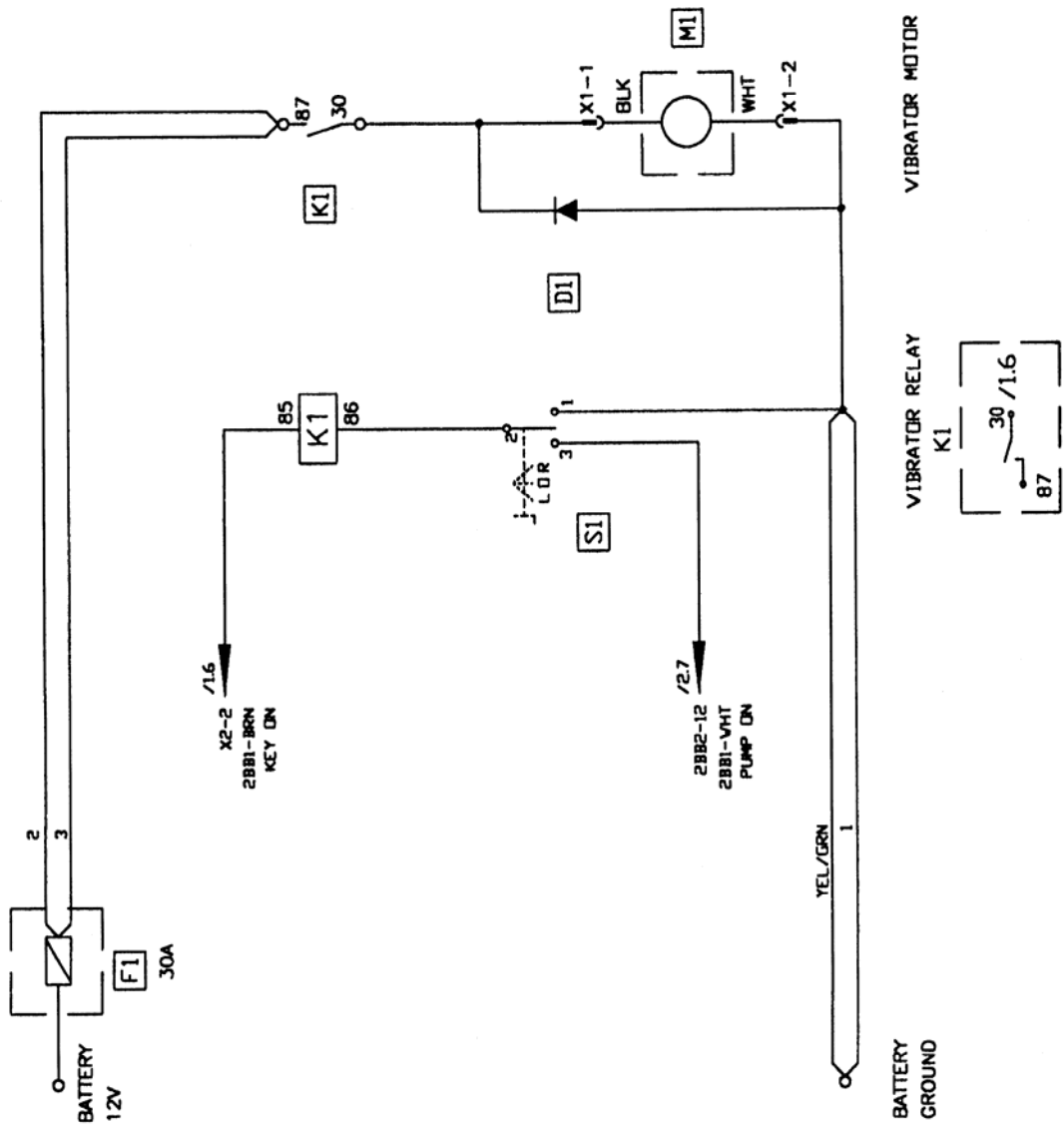

REVISION:



TRAILER MOUNTED PUMP MODEL C50HP RADIO REMOTE CONTROL OPTION ELECTRICAL SCHEMATIC

SCMTC

PAGE 17

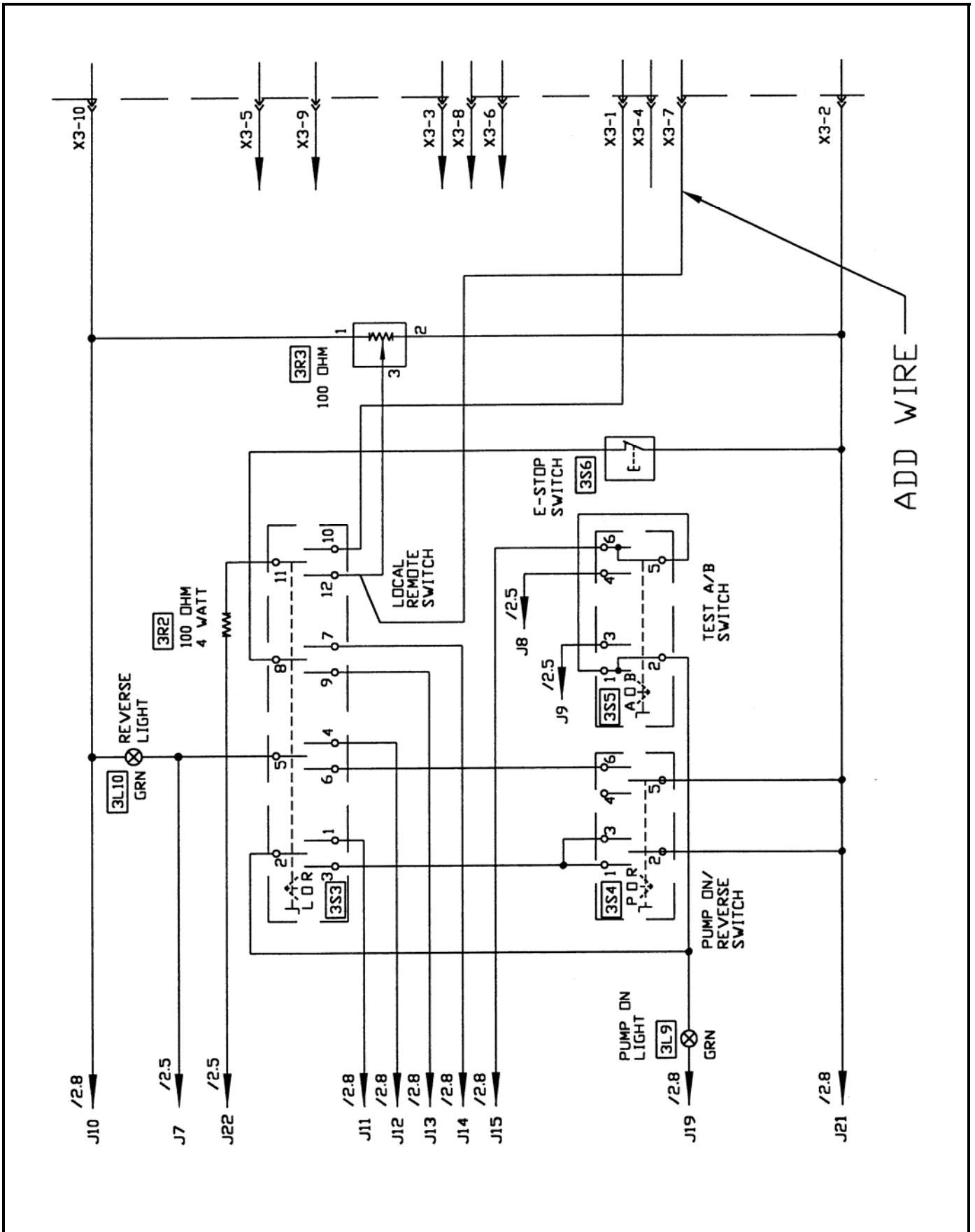

REVISION:



**TRAILER MOUNTED PUMP
MODEL C50HP
HYDRAULIC HOSE KIT**

SCMTC

PAGE 18

No.	Part No.	End #1	End #2
DRIVE CYLINDER CIRCUIT			
H01	85664-002	Tank Suction	Main Pump "S"
H02	85666-003	Main Pump "A"	Cylinder "A"
H03	85666-003	Main Pump "B"	Cylinder "B"
H04	85659-011	Main Pump "M2"	Hot Oil Shuttle "B"
H05	85659-004	Main Pump "M2"	Relief Valve (B) "1"
H06	85659-012	Main Pump "M4"	Relief Valve (B) "2"
H07	85659-004	Main Pump "M1"	Relief Valve (A) "1"
H08	85659-012	Main Pump "M5"	Relief Valve (A) "2"
H09	85659-013	Main Pump "M2"	Shuttle Valve
H10	85659-013	Main Pump "M1"	Shuttle Valve
H11	85654-002	Main Pump "L1"	Tank - 25 psi Check
H12	85654-003	Main Pump "L1"	Oil Cooler "IN"
H13	85654-004	Oil Cooler "OUT"	Tank Return Filter
H14	85659-014	Main Pump "CD"	Hot Oil Shuttle "T"
H15			
H16			
H17	85659-002	Check Loop	
H18	85659-002	Check Loop	
H19	85659-002	Check Loop	
H20	85659-002	Check Loop	
SWING TUBE CIRCUIT			
H21	85663-003	Tank Suction	Tandem Pump "S"
H22	85657-002	Tandem Pump 12 cc	Swing Tube Manifold "P2"
H23	85667-002	Swing Tube Manifold "ACC"	Accumulator
H24	85657-002	Swing Ram Bulkhead "A"	Swing Ram (A)
H25	85657-002	Swing Ram Bulkhead "B"	Swing Ram (B)
H26			
AGITATOR / OUTRIGGER CIRCUIT			
H27	85657-007	Tandem Pump 10 cc	Bulkhead "P" Tee
H28	85657-002	Bulkhead "P" Tee	Bypass Valve "1"
H29	85657-006	Bulkhead "P"	Agitator - O/R Valve "P"
H30	85658-003	Agitator Valve "A"	Agitator Motor "A"
H31	85658-003	Agitator Valve "B"	Agitator Motor "B"
H32	85659-010	O/R Valve "A"	RH Outrigger Bore
H33	85659-010	O/R Valve "B"	RH Outrigger Rod
H34	85659-010	O/R Valve Tube "A"	LH Outrigger Bore
H35	85659-010	O/R Valve Tube "B"	LH Outrigger Rod
H36	85657-002	Agitator - O/R Valve "T"	Bulkhead "T"
H37	85657-002	Bulkhead "T"	Tank Return
FUEL SYSTEM			
	85669-001	Fuel Tank	Fuel Filter "IN"
	85669-003	Fuel Filter "OUT"	Engine
	85669-004	Fuel Tank Crossover	

REVISION:

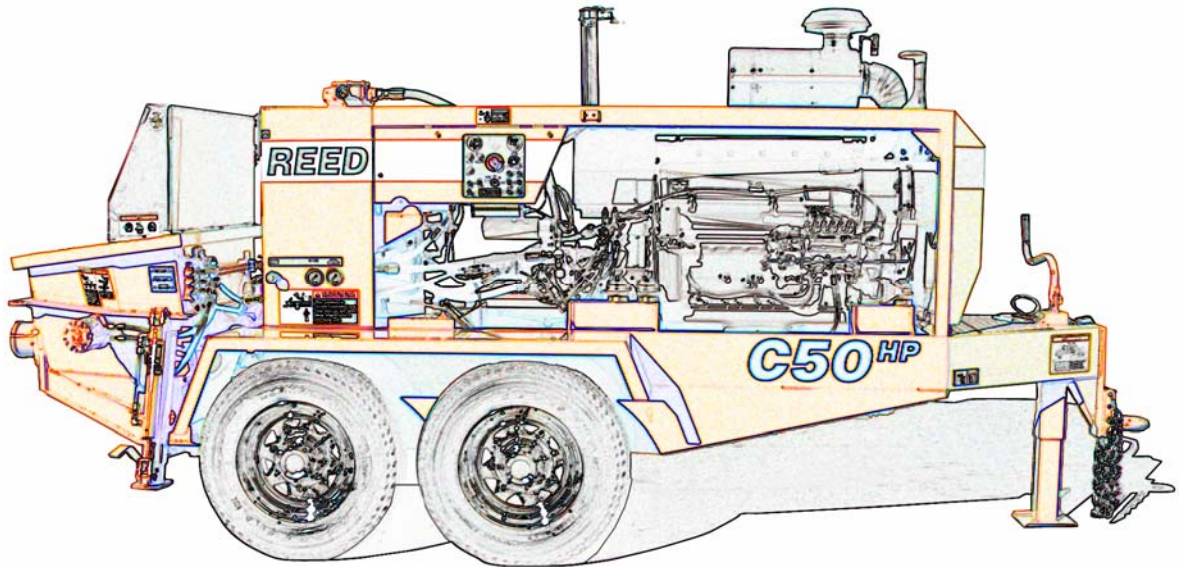

REED TRAILER MOUNTED CONCRETE PUMP 02 MODEL C50HP ILLUSTRATED PARTS MANUAL CONTAINS THE FOLLOWING GROUPS AND FIGURES:

GROUP 00 HOW TO USE PARTS MANUAL

- FIGURE 00** TABLE OF CONTENTS
- FIGURE 01** HOW TO USE PARTS MANUAL
- FIGURE 02** HOW TO ORDER PARTS

GROUP 10 FINAL INSTALLATION

- FIGURE 00** TABLE OF CONTENTS
- FIGURE 01** FINAL INSTALLATION
- FIGURE 02** DECAL ASSEMBLY

GROUP 20 HOPPER INSTALLATION

- FIGURE 00** TABLE OF CONTENTS
- FIGURE 01** HOPPER INSTALLATION
- FIGURE 02** HOPPER CLEAN OUT DOOR ASSEMBLY
- FIGURE 03** AGITATOR ASSEMBLY
- FIGURE 04** AGITATOR MOTOR ASSEMBLY
- FIGURE 05** AGITATOR/OUTRIGGERS CONTROL VALVE ASSEMBLY
- FIGURE 06** AGITATOR/OUTRIGGER CONTROL VALVE SUB-ASSEMBLY

GROUP 30 TANK INSTALLATION

FIGURE 00	TABLE OF CONTENTS
FIGURE 01	TANK INSTALLATION
FIGURE 02	HYDRAULIC TANK ASSEMBLY
FIGURE 03	ACCUMULATOR ASSEMBLY
FIGURE 04	ACCUMULATOR BLADDER REPAIR KIT
FIGURE 05	SWING TUBE CIRCUIT MANIFOLD ASSEMBLY
FIGURE 06	SWING TUBE CIRCUIT MAIN SOLENOID VALVE ASSEMBLY
FIGURE 07	SWING TUBE CIRCUIT PILOT SOLENOID VALVE ASSEMBLY
FIGURE 08	BALL VALVE ASSEMBLY

GROUP 40 POWER TRAIN INSTALLATION

FIGURE 00	TABLE OF CONTENTS
FIGURE 01	POWER TRAIN INSTALLATION
FIGURE 02	POWER TRAIN ASSEMBLY
FIGURE 03	DOUBLE AUXILIARY PUMP ASSEMBLY
FIGURE 04	SINGLE AUXILIARY PUMP ASSEMBLY (OPTIONAL)
FIGURE 05	HOT OIL SHUTTLE ASSEMBLY
FIGURE 06	MAIN HYDRAULIC PUMP ASSEMBLY
FIGURE 07	BATTERY MOUNTING ASSEMBLY

GROUP 50 CONTROLS INSTALLATION

FIGURE 00	TABLE OF CONTENTS
FIGURE 01	CONTROLS INSTALLATION
FIGURE 02	CONTROL BOX ASSEMBLY
FIGURE 03	50 FEET CABLE REMOTE CONTROL ASSEMBLY
FIGURE 04	100 FEET CABLE REMOTE CONTROL ASSEMBLY
FIGURE 05	RADIO REMOTE CONTROL ASSEMBLY

GROUP 60 PUMPING TRAIN INSTALLATION

FIGURE 00	TABLE OF CONTENTS
FIGURE 01	PUMPING TRAIN INSTALLATION
FIGURE 02	SWING VALVE ASSEMBLY
FIGURE 03	SWING RAM CYLINDER SUB-ASSEMBLY
FIGURE 04	CONCRETE CYLINDER ASSEMBLY
FIGURE 05	FLUSHBOX ASSEMBLY
FIGURE 06	HYDRAULIC DRIVE CYLINDER ASSEMBLY
FIGURE 07	HYDRAULIC DRIVE CYLINDER SUB-ASSEMBLY

GROUP 70 FRAME INSTALLATION

FIGURE 00	TABLE OF CONTENTS
FIGURE 01	FRAME INSTALLATION
FIGURE 02	HYDRAULIC OUTRIGGER CYLINDER ASSEMBLY
FIGURE 03	HUB AND BRAKE ASSEMBLY
FIGURE 04	NON-OPERATOR SIDE ELECTRIC BRAKE ASSEMBLY
FIGURE 05	OPERATOR SIDE ELECTRIC BRAKE ASSEMBLY

GROUP 80 OPTIONAL INSTALLATION

FIGURE 00	TABLE OF CONTENTS
FIGURE 01	OPTIONAL INSTALLATION
FIGURE 02	LUBE SYSTEM ASSEMBLY
FIGURE 03	12 VOLT LUBE PUMP ASSEMBLY
FIGURE 04	HOPPER VIBRATOR ASSEMBLY
FIGURE 05	CHROME WHEEL ASSEMBLY
FIGURE 06	OPTIONAL TOOL KIT ASSEMBLY
FIGURE 07	ACTUATOR BRAKES ASSEMBLY
FIGURE 08	WASH PUMP ASSEMBLY
FIGURE 09	WASH PUMP CONTROL VALVE ASSEMBLY
FIGURE 10	WASH PUMP MOTOR ASSEMBLY
FIGURE 11	ACCUMULATOR CHARGE KIT
FIGURE 12	NON-OPERATOR SIDE HYDRAULIC BRAKE ASSEMBLY
FIGURE 13	OPERATOR SIDE HYDRAULIC BRAKE ASSEMBLY
FIGURE 14	1 SPOOL CONTROL VALVE ASSEMBLY
FIGURE 15	1 SPOOL CONTROL VALVE SUB-ASSEMBLY
FIGURE 16	2 SPOOL CONTROL VALVE ASSEMBLY
FIGURE 17	2 SPOOL CONTROL VALVE SUB-ASSEMBLY





**TRAILER MOUNTED PUMP MODEL C50HP
HOW TO USE PART MANUAL**

**C50HPS
PARTS
GROUP 00
FIGURE 01
PAGE 01**

I. PURPOSE

This parts manual is prepared, issued and/or revised by **REED** Manufacturing, for the exclusive use of its customers and is intended for use in provisioning, requisitioning, storing and issuing replaceable **REED** trailer mounted pump **02** model **C50HP**. The contents are proprietary to **REED** and are subject to change without notice. The use of any part of this document by any other person or persons or for any other purpose without the written consent of **REED** is expressly prohibited. In addition, **REED** expressly disclaims any and all responsibility arising in or any way related to such **REED**'s prior written consent thereto.

The parts number content of this document, arrangement and breakdown sequence of items is compatible with Military Standard (**MS**) and Air Transport Association Specification (**ATA**).

II. GENERAL SYSTEM OF ASSEMBLY ORDER – Detailed Parts List (Refer to Next Page)

1. This area refers to the corresponding illustration

MODEL – GROUP – FIGURE – PAGE

A. MODEL shows which is **REED**'s model number.

B. GROUP should be divided with:

- 00** **02** MODEL **C50HP** PARTS MANUAL
- 10** FINAL INSTALLATION
- 20** HOPPER INSTALLATION
- 30** TANK INSTALLATION
- 40** POWER TRAIN INSTALLATION
- 50** CONTROL INSTALLATION
- 60** PUMPING TRAIN INSTALLATION
- 70** FRAME INSTALLATION
- 80** OPTIONAL INSTALLATION

C. FIGURE belong to the group. Please see page of contents and each group.

D. PAGE numbers follow to the right of each figure number.

2. The **ITEM NUMBER** corresponds to the item number shown for the part in illustration. Parts with item number preceded by a dash (such as: -1, -5, -12 etc.) are not illustrated.

3. **PARTS NUMBERS** that carry a **REED** part number.



TRAILER MOUNTED PUMP MODEL C50HP HOW TO USE PART MANUAL

C50HP
PARTS
GROUP 00
FIGURE 01
PAGE 02

DUAL SHIFT SWING VALVE ASSEMBLY

01 B40
PARTS
GROUP 60
FIGURE 04
PAGE 02

ITEM NO.	REED'S PARTS NO.	DESCRIPTION					QTY
		1	2	3	4	5	
-1	60-04	Assembly, Dual Shift Swing Valve (See Group 60, Figure 02 for NHA)					Ref
-2	86321	• Assembly, Outlet Group					1
3		•• Nut					6
4	72482	•• Outlet, Machine 5"					1
5		•• Fitting, Grease					2
6	79895	•• Kit, Outlet Seal					1
7	77761	••• O-Ring, Large					1
8	77762	••• O-Ring, Small					1
9	86504	••• Seal, Modified Outlet Thick					1
10	77763	••• Band, Guide					1
11	77765	••• Seal, Outlet Thick					1
12	72309	•• Housing, Outlet Seal					1
13		•• Bolt, Hex					6
14		•• Nut, Nylock (attaching parts)					6
15		•• Washer, Lock (attaching parts)					6
16	70042	•• Outlet, Chromed					1
17		•• Bolt, Hex (attaching parts)					6
-18	86317	• Assembly, Swing Tube Group					1
19	85965	•• Weldment, Harsh Swing Tube					1
20	86065	•• Seal, 6 Inch Single Lip					1
21	72310	•• Ring, 6 Inch Single Lip Wear					1
22	86031	•• Plate, Wear					1
23	86086	•• Ring, Anti Chip					2
24		•• Bolt, Flat Head					4
25		•• Washer, Lock					4
26		•• Nut, Hex					4
27		•• Bolt, Hex					6
28		•• Washer, Lock					6
29	85962	•• Seal, Flange Bearing					1
30		•• Pin, Dowel					1
31		•• Fitting, Grease 90					2
32	85133	•• Bearing, 3 Inch Spline Flange					1
33	85294	•• Washer, Thrust					1
34	85134	•• Spacer, Swing Tube Nut					1
35	70825	•• Nut, Swing Tube					1
36		•• Pin Cotter					1
-37	86320	• Assembly, Swing Tube Dual Shift Group					1
38		•• Plug, Pipe					4
39	86052	•• Pin, Spring					4
40		•• Fitting, Grease 90					2
41	86441	•• Retainer, Swing Ram					2

DASH (-) ITEM NOT ILLUSTRATED

REVISION:

REVISION:

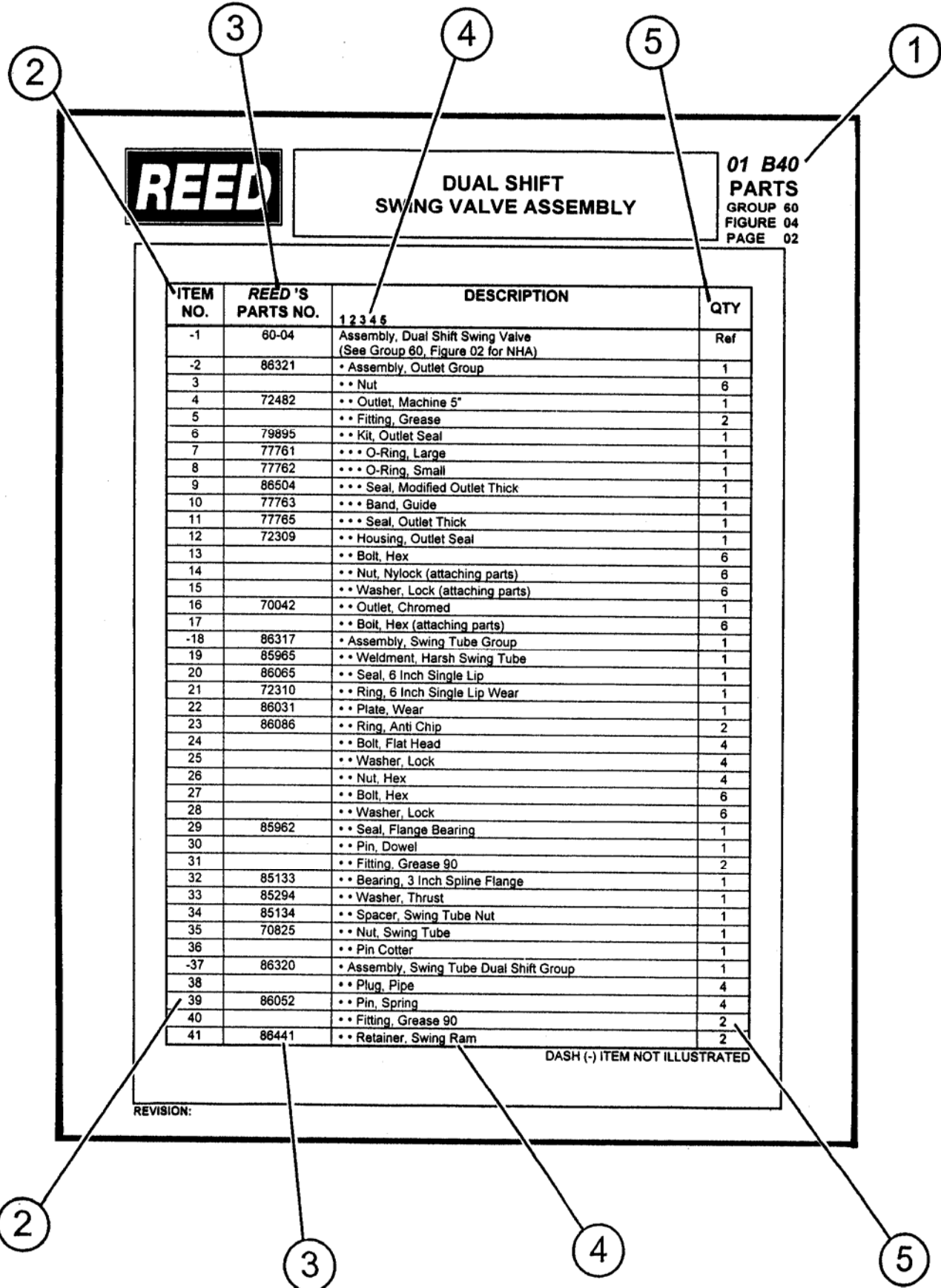



TRAILER MOUNTED PUMP MODEL C50HP HOW TO USE PART MANUAL

C50HP
PARTS
GROUP 00
FIGURE 01
PAGE 04

4. DESCRIPTION

A. The **INDENTURE SYSTEM** used in the parts list shows the relationship of one part to another. For a given item, the number of indentures depicts the relationship of the item to the components of the item as follows:

1 2 3 4 5

Assembly (or Installation)

- **Detail part of assembly**
- **Sub-assembly**
- **Attaching parts for sub-assembly**
 - • **Detail part of sub-assembly**
 - • **Sub-sub-assembly**
 - • **Attaching parts for sub-sub-assembly**
 - • • **Detail part of sub-sub-assembly**
 - • • **Sub-sub-sub-assembly**
 - • • **Attaching parts of sub-sub-sub-assembly**
 - • • • **Detail part of sub-sub-sub-assembly**

B. "See Group 60, Figure 02 For **NHA**"

Identifies the illustrated parts chapter location; indicates where the Next Higher Assembly (**NHA**) of the item shown.

C. "See Group 60, Figure 07 For **DET**"

Identifies the illustrated parts chapter location; indicates where the item and its Detailed Breakdown (**DET**) is shown.

D. "See Group 30, Figure 05 for **REF**" or "See Vendor Chapter For **REF**"

Identifies the illustrated parts chapter where the part is, and if listed and illustrated in Vendor Chapter. It is used as a cross-reference (**REF**).

5. QUANTITY

A. Reference (**REF**) indicates the items that is listed previously in the Next Higher Assembly (**NHA**) and then again in this figure.

B. As Required (**A/R**) indicates the parts that is used in a quantity as required.

C. A number entry indicates the quantity of the part used in its next higher application.

6. Functionally related assemblies are illustrated in phantom (— — — —) but not listed on the detail parts list page.

REVISION:



TRAILER MOUNTED PUMP MODEL C50HP HOW TO ORDER PARTS

C50HP
PARTS
GROUP 00
FIGURE 02
PAGE 01

1. Always give serial number and model of **REED** trailer mounted concrete pump **02** model **C50HP**. (Refer to each unit name plate shown below). NOTE: This manual is being released to cover unit starting with serial number **3-04-1-2107** to current production. Some components used on earlier units differ from current productions. Where this occurs, the part is identified by a serial number.

REED		PHONE (909) 287-2100	
13822 OAKS AVENUE		FAX (909) 287-2140	
CHINO, CA 91710 USA			
MODEL		SERIAL NO	
MATERIAL PRESSURE		PSI	
HYDRAULIC PRESSURE		PSI	
ENGINE / PTO ELECTRIC MOTOR		RPM	
PN 96636			

2. Always specify part number and complete name of parts ordered.
- A. Turn to table of content in the desired Installation. Refer to main group in which part should be listed.
 - B. Find title of figure in which the part should be shown. Note figure number.

TRAILER MOUNTED PUMP 01 MODEL B40

GROUP 60 PUMPING TRAIN INSTALLATION

01 B40

PARTS

GROUP 60

FIGURE 00

PAGE 01

SHOWN MODEL DUAL SHIFT HARSH MIX HOPPER UNIT

REED TRAILER MOUNTED CONCRETE PUMP 01 MODEL B45 ILLUSTRATED PARTS MANUAL GROUP 60 PUMPING TRAIN INSTALLATION CONTAINS THE FOLLOWING FIGURES:

FIGURE 00	TABLE OF CONTENTS
FIGURE 01	SINGLE SHIFT PUMPING TRAIN INSTALLATION
FIGURE 02	DUAL SHIFT PUMPING TRAIN INSTALLATION
FIGURE 03	SINGLE SHIFT SWING VALVE ASSEMBLY
FIGURE 04	DUAL SHIFT SWING VALVE ASSEMBLY
FIGURE 05	SINGLE SHIFT SWING RAM CYLINDER SUB-ASSEMBLY
FIGURE 06	DUAL SHIFT SWING RAM CYLINDER SUB-ASSEMBLY
FIGURE 07	MATERIAL CYLINDER ASSEMBLY
FIGURE 08	FLUSHBOX ASSEMBLY
FIGURE 09	HYDRAULIC DRIVE CYLINDER ASSEMBLY
FIGURE 10	HYDRAULIC DRIVE CYLINDER SUB-ASSEMBLY

REVISION:

REVISION:

REED **DUAL SHIFT SWING VALVE ASSEMBLY** 01 B40 PARTS GROUP 00 FIGURE 04 PAGE 01

HOPPER REF (STANDARD P/N: 88107) (HARSH MIX P/N: 88032)

SWING RAM HOUSE REF (RH P/N: 85941) (LH P/N: 85942)

HOPPER REF (STANDARD P/N: 88107) (HARSH MIX P/N: 88032)

REVISION:

REED **DUAL SHIFT SWING VALVE ASSEMBLY** 01 B40 PARTS GROUP 00 FIGURE 04 PAGE 02

ITEM NO.	REED'S PARTS NO.	DESCRIPTION	QTY
-1	60-04	Assembly, Dual Shift Swing Valve (See Group 60, Figure 02 for NHA)	Ref
-2	86321	Assembly, Outlet Group	1
3		** Nut	6
4	72482	** Outlet, Machine 5"	1
5		** Fitting, Grease	2
6	79895	** Kit, Outlet Seal	1
7	77781	** O-Ring, Large	1
8	77782	** O-Ring, Small	1
9	86504	** Seal, Modified Outlet Thick	1
10	77783	** Band, Guide	1
11	77785	** Seal, Outlet Thick	1
12	72309	** Housing, Outlet Seal	1
13		** Bolt, Hex	6
14		** Nut, Nylock (attaching parts)	6
15		** Washer, Lock (attaching parts)	6
16	70042	** Outlet, Chromed	1
17		** Bolt, Hex (attaching parts)	6
-18	86317	Assembly, Swing Tube Group	1
19	85965	** Weldment, Harsh Swing Tube	1
20	86085	** Seal, 6 Inch Single Lip	1
21	72310	** Ring, 6 Inch Single Lip Wear	1
22	86031	** Plate, Wear	1
23	86086	** Ring, Anti Chip	2
24		** Bolt, Flat Head	4
25		** Washer, Lock	4
26		** Nut, Hex	4
27		** Bolt, Hex	6
28		** Washer, Lock	6
29	85962	** Seal, Flange Bearing	1
30		** Pin, Dowel	1
31		** Fitting, Grease 90	2
32	80723	** Bearing, 3 Inch Spring Flange	1
33	85294	** Washer, Thrust	1
34	86184	** Spacer, Swing Tube Nut	1
35	70825	** Nut, Swing Tube	1
36		** Pin Cotter	1
-37	86320	Assembly, Swing Tube Dual Shift Group	1
38		** Plug, Pipe	4
39	86082	** Pin, Spring	4
40		** Fitting, Grease 90	2
41	86441	** Retainer, Swing Ram	2

DASH (-) ITEM NOT ILLUSTRATED

REVISION:

C. Turn to corresponding page, find the group and figure.

D. Check your required part and its attaching parts and match with illustration page.

E. Refer to corresponding item number in the part list page.
Part numbers are located in the part number column.

F. When ordering variable or optional miscellaneous parts which are not found this in parts chapter, follow the above outlined procedure of how to order parts.

1). When applicable, give model and serial number of the component for which parts are desired.

2). In a specific, difficult to describe situation, a marked-up photograph or detailed sketch would be helpful.



**TRAILER MOUNTED PUMP MODEL C50HP
HOW TO ORDER PARTS**

**C50HP
PARTS
GROUP 00
FIGURE 02
PAGE 03**

3. Do not designate quantity by "set". State specifically how many parts are wanted.
4. Always give complete address and full shipping instructions. Specify shipping instructions, truck freight, air freight. United Parcel Service (UPS), or FEDEX and DHL are available in designated areas.

5. TO ORDER

A. BY MAIL

Attention: Parts Department
REED
13822 Oaks Avenue
Chino, CA. 91710

B. BY FAX

(909) 287 - 2141

C. BY PHONE

(909) 287 - 2100

6. Parts return without authorization will not be accepted. If it is necessary to return parts for any reason, written authorization may be obtained from **REED** Parts Department, Chino, CA. 91710-7008. A Parts Return Authorization form is provided when **REED** deems its necessary to have the part returned for evaluation. The form is issued by the Warranty of Parts Department of **REED**.
 - A. The form will be filled by **REED** unless requesting necessary information and you will receive a copy as well as shipping tag.
 - B. Attach shipping tag to part insert return original invoice.
 - C. Ship part to **REED PREPAID**.
 - D. Part must be returned to **REED** within 30 days from date of authorization.

REED TRAILER MOUNTED CONCRETE PUMP 02 MODEL C50HP ILLUSTRATED PARTS MANUAL GROUP 10 FINAL INSTALLATION CONTAINS THE FOLLOWING FIGURES:

- FIGURE 00** TABLE OF CONTENTS
- FIGURE 01** FINAL INSTALLATION
- FIGURE 02** DECAL ASSEMBLY

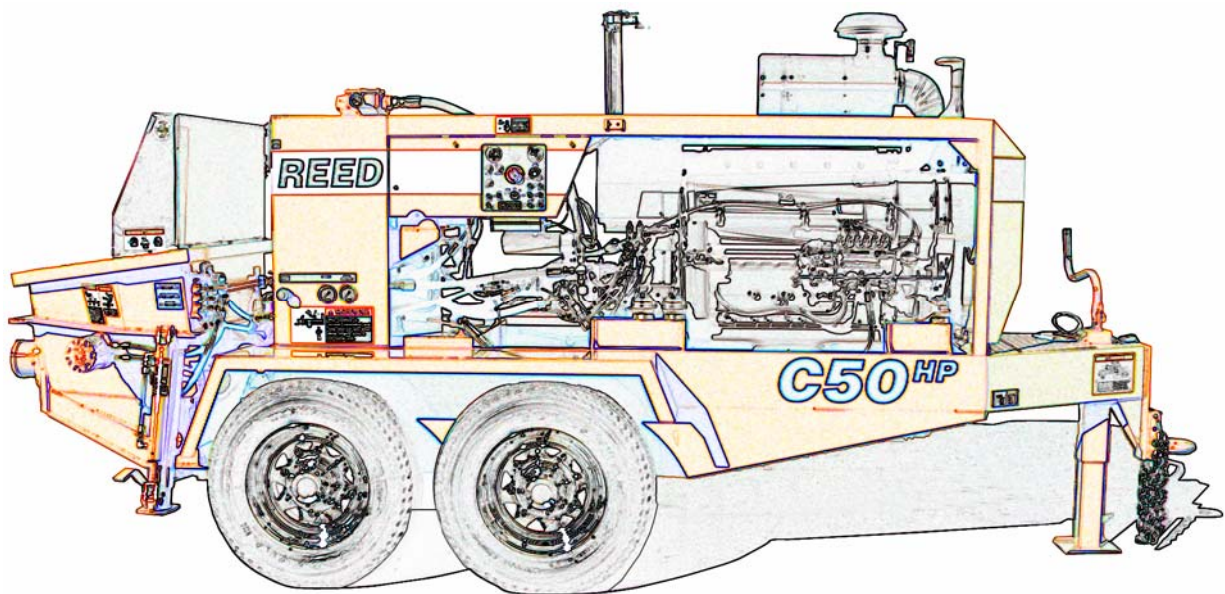



STANDARD HOPPER WITH
DUAL SHIFT FINAL INSTALLATION

C50HP
PARTS
GROUP 10
FIGURE 01
PAGE 01

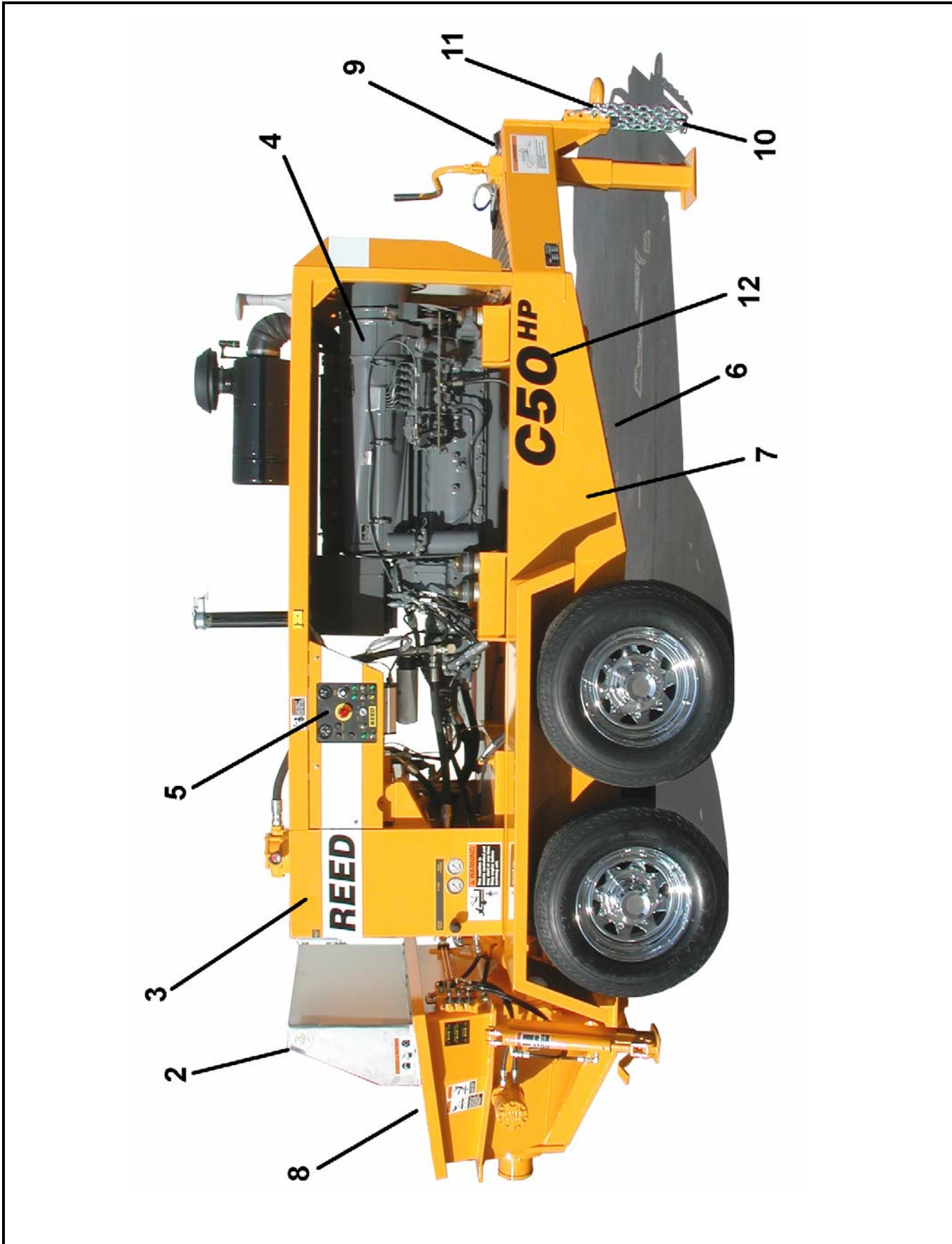

REVISION:



STANDARD HOPPER WITH DUAL SHIFT FINAL INSTALLATION

C50HP
PARTS
GROUP 10
FIGURE 01
PAGE 02

ITEM NO.	REED'S PARTS NO.	DESCRIPTION					QTY
		1	2	3	4	5	
-1	C50HPC-V02	Installation, C50HP Std Hopper with Dual Shift Final					Ref
2	20-02	• Installation, Hopper (See Group 20, Figure 01 for DET)					1
3	30-01	• Installation, Tank (See Group 30, Figure 01 for DET)					1
4	40-01	• Installation, Power Train (See Group 40, Figure 01 for DET)					1
5	50-01	• Installation, Control (See Group 50, Figure 01 for DET)					1
6	60-01	• Installation, Dual Shift Pumping Train (See Group 60, Figure 01 for DET)					1
7	70-01	• Installation, Frame (See Group 70, Figure 01 for DET)					1
8	80-01	• Installation, Optional (See Group 80, Figure 01 for DET)					1
9	77705	• Kit, Break Away					1
10	86730	• Chain 5.5FT					2
11	87085	• Shackle Anchor-Screw Pin 1/2"					4
12	10-03	• Kit, C50HP Decal (See Group 10, Figure 02 for DET)					1

DASH (-) ITEM NOT ILLUSTRATED

REVISION:



DECAL ASSEMBLY

C50HP
PARTS
GROUP 10
FIGURE 02
PAGE 01

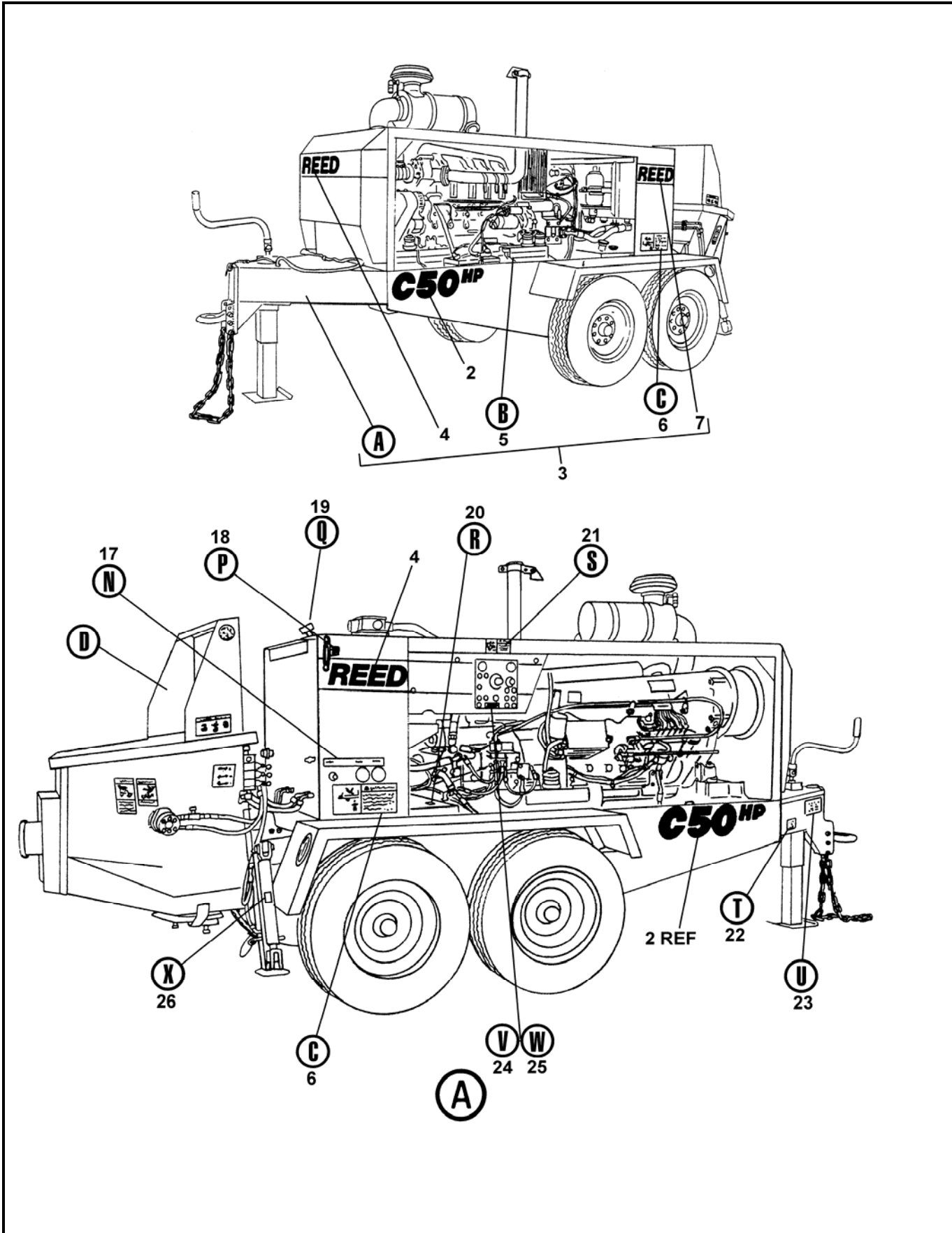

REVISION:



ITEM NO.	REED'S PARTS NO.	DESCRIPTION					QTY
		1	2	3	4	5	
-1	10-02	Kit, C50HP Decal (See Group 10, Figure 01 for NHA)					Ref
2	85415	• Decal, C50HP 6 Inch Black					2
3	85430	• Kit, C-Series Decal					1
4	85418	•• Decal, REED 4 1/2 Inch Black and White 48 Inch					2
5	800916	•• Decal, Warning, Keep Hand Out of Water Box					1
6	800924	•• Decal, Warning, This Machine is Remote Controlled and					2
7	85416	•• Decal, REED 4 1/2 Inch Black and White 20 Inch					1
8	800922	•• Decal, Warning, Before Opening a Blocked Pipeline,					1
9	800921	•• Decal, Warning, Do Not Operate at Pressures Exceeding					1
10	73132	•• Decal, REED 4 1/2 Inch					1
11	800931	•• Decal, ACPA Member					1
12	800929A	•• Decal, Warning					2
13	85846	•• Decal, Agitator					1
14	85845	•• Decal, Outriggers					1
15	800917	•• Decal, Warning, Keep Hand Out of Hopper and Valve					2
16	800918	•• Decal, Warning, Do Not Stand on Hopper Grate					2
17	85684	•• Decal, C-Series Gauge					1
18	75020	•• Decal, Hydraulic Oil					1
19	85844	•• Decal, Oil Level					1
20	75017	•• Decal, Diesel Fuel Only					1
21	800926	•• Decal, Warning, Do Not Operate This Machine without					1
22	75009	•• Nameplate, REED , Serial No.					1
23	86245	•• Decal, Warning, Towing Instruction					1
24	85409	• Decal, C50HP Control Box Panel					1
25	85411	• Decal, C50HP Remote Control					1
26	800919	• Decal, Optional, Warning, Stand Clear Outriggers When					2

DASH (-) ITEM NOT ILLUSTRATED



! WARNING

This machine is remote controlled and may start at any time. Stop engine before servicing unit.

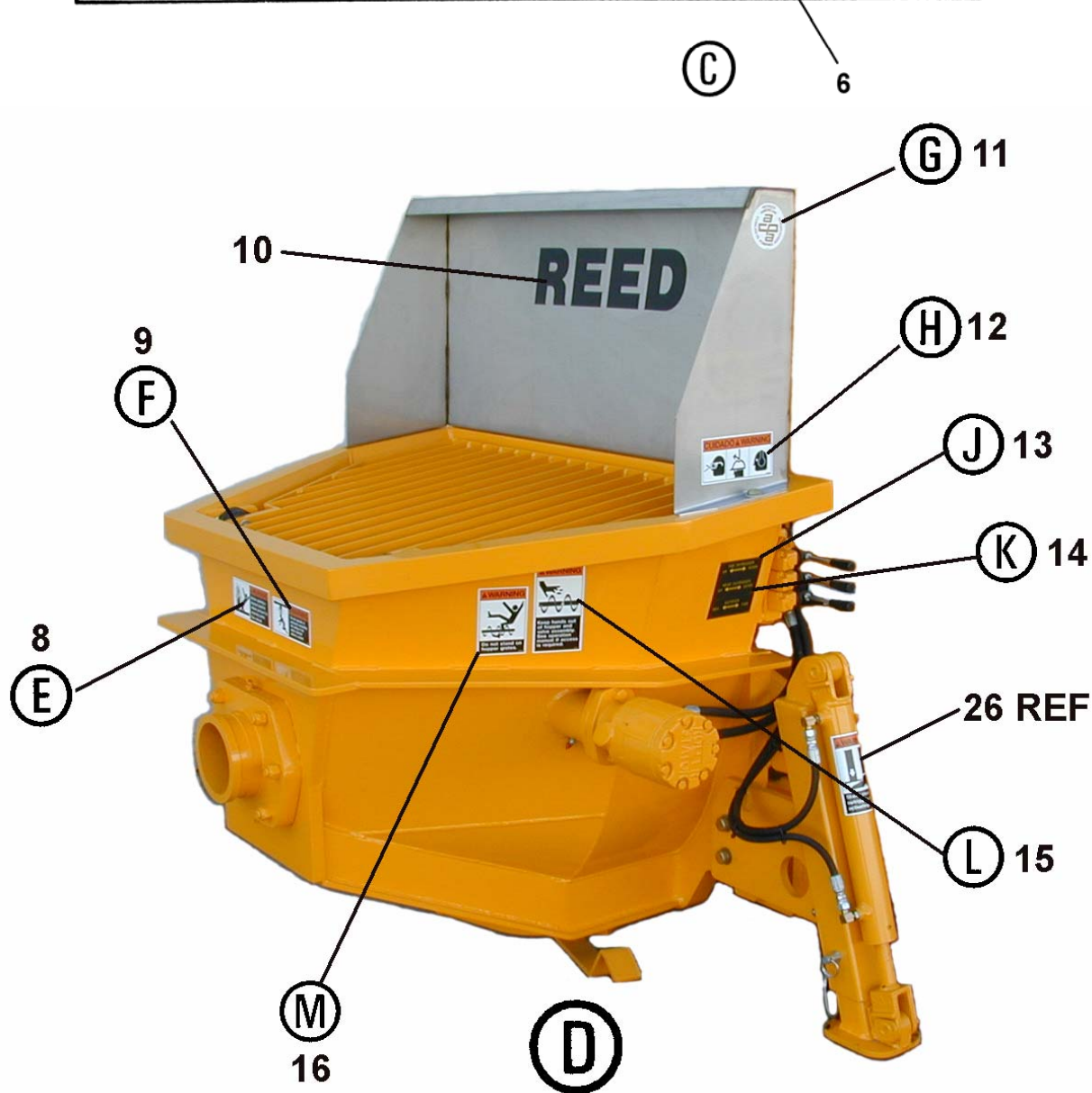

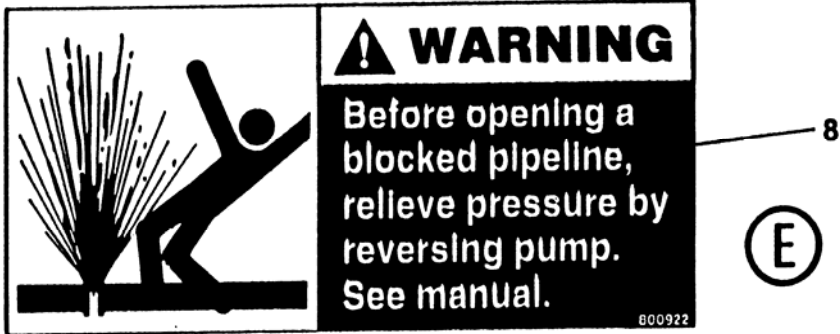



DECAL ASSEMBLY

C50HP
PARTS
GROUP 10
FIGURE 02
PAGE 05

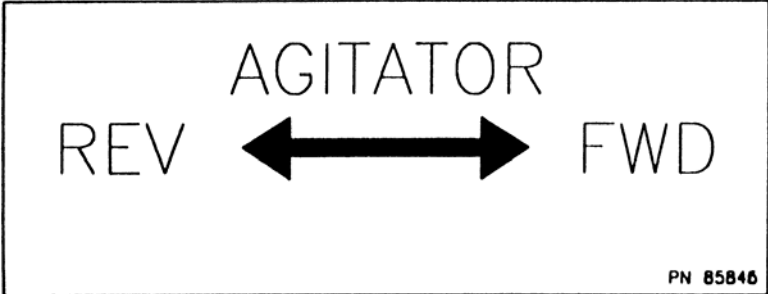

13

ⓐ



Ⓛ

15

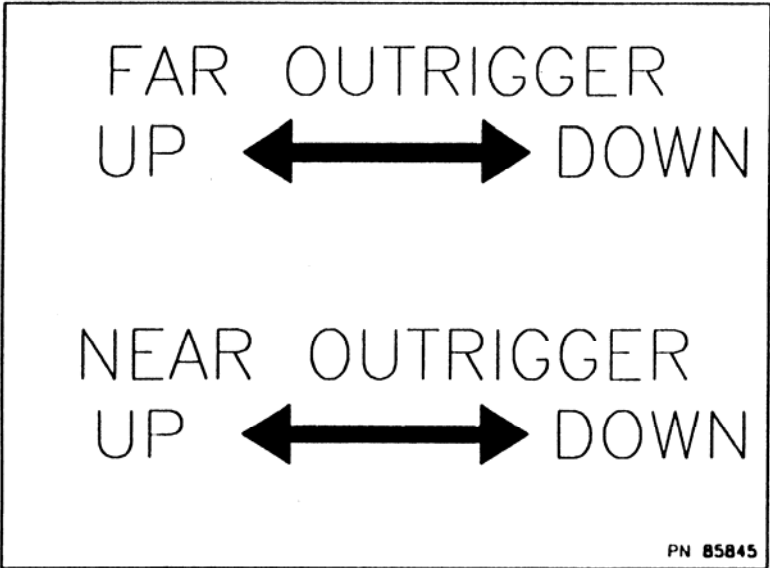

14

Ⓚ

ENGINE SPEED	S-TUBE	DRIVE CYLINDER
-----------------	--------	-------------------

(N)

17

⚠ WARNING



**Do not stand on
hopper grates.**

600918

16

HYDRAULIC OIL



MAX. LEVEL

PN 85844

(P)

18

HYDRAULIC OIL

19

(Q)

DIESEL FUEL
ONLY

20

(R)



(S)

21

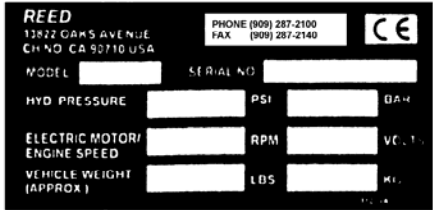

22

(T)

! WARNING

34" MINIMUM

- THE TONGUE WEIGHT ON TANDEM AXLE TRAILERS DECREASES AS THE TONGUE IS LOWERED.
- TOWING WITH INSUFFICIENT TONGUE WEIGHT MAY CAUSE INSTABILITY OF THE TRAILER.
- REED C-SERIES MODELS MUST BE TOWED WITH A MINIMUM TONGUE HEIGHT OF 34 INCHES.

PN 86245

(U)

23

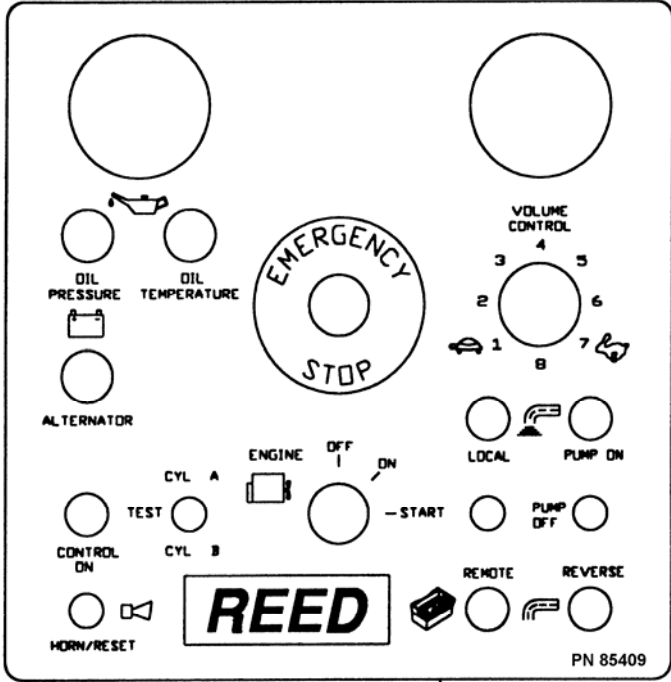

(V) 24

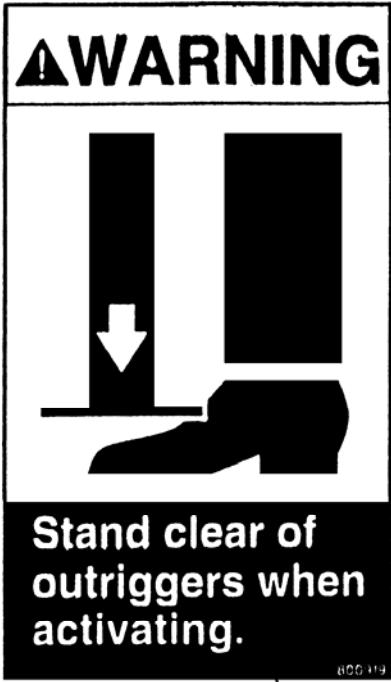

(X) 26

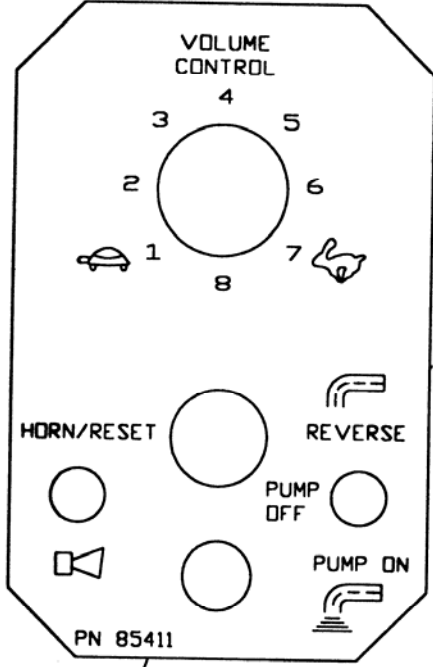

25 (W)



TRAILER MOUNTED PUMP 02 MODEL C50HP
GROUP 10 FINAL INSTALLATION

C50HP
PARTS
GROUP 10
FIGURE 03
PAGE 01

THIS PAGE INTENTIONALLY LEFT BLANK.

REED TRAILER MOUNTED CONCRETE PUMP 02 MODEL **C50HP** ILLUSTRATED PARTS MANUAL GROUP 20 HOPPER INSTALLATION CONTAINS THE FOLLOWING FIGURES:

- FIGURE 00** TABLE OF CONTENTS
- FIGURE 01** STANDARD HOPPER INSTALLATION
- FIGURE 02** ROUNDED CLEAN OUT DOOR ASSEMBLY
- FIGURE 03** AGITATOR ASSEMBLY
- FIGURE 04** AGITATOR MOTOR ASSEMBLY
- FIGURE 05** AGITATOR/OUTRIGGERS CONTROL VALVE ASSEMBLY
- FIGURE 06** AGITATOR/OUTRIGGERS CONTROL VALVE SUB-ASSEMBLY





STANDARD HOPPER INSTALLATION

C50HP
PARTS
GROUP 20
FIGURE 01
PAGE 01

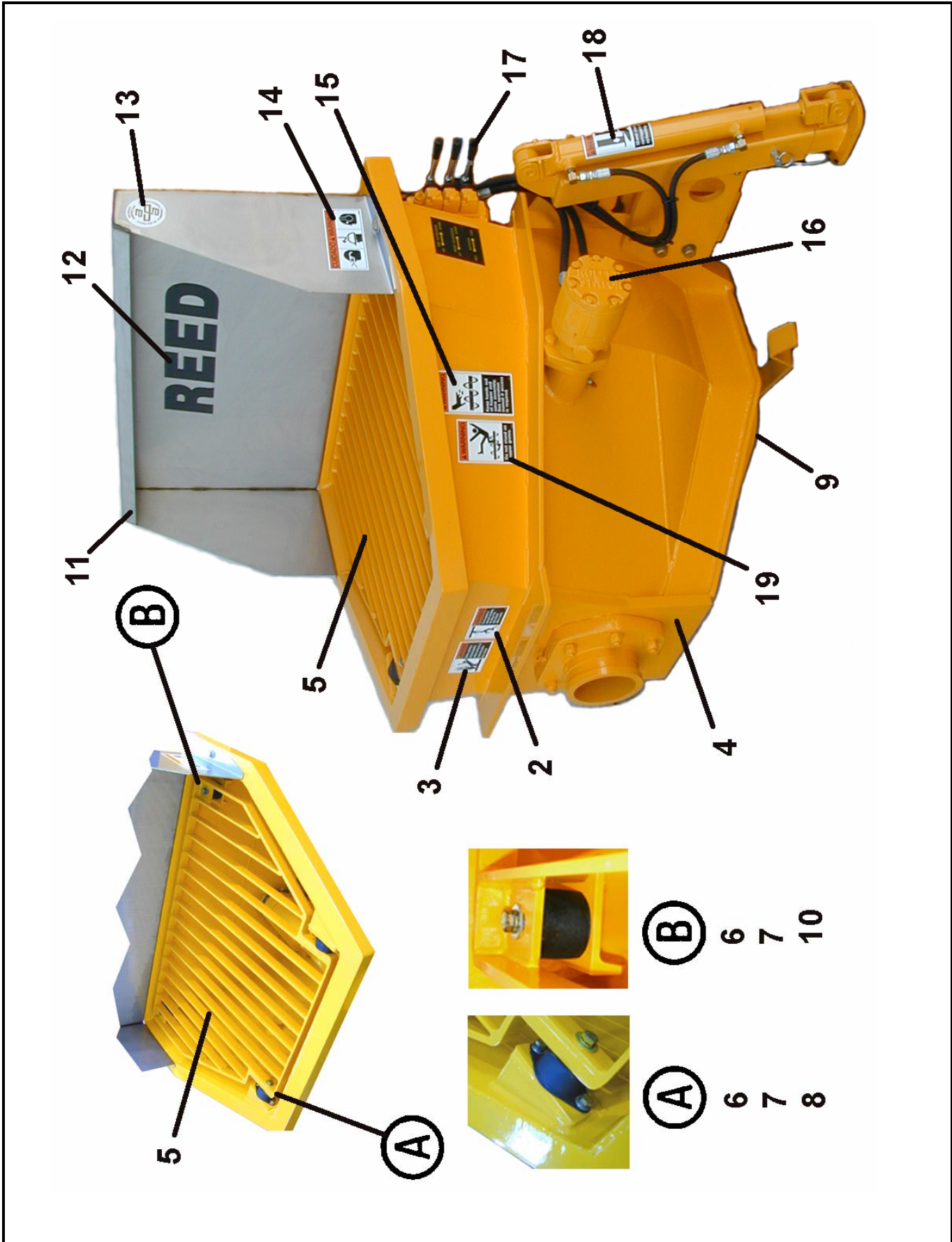

REVISION:



STANDARD HOPPER INSTALLATION

C50HP
PARTS
GROUP 20
FIGURE 01
PAGE 02

ITEM NO.	REED'S PARTS NO.	DESCRIPTION	QTY
		1 2 3 4 5	
-1	20-01	Installation, Standard Hopper (See Group 10, Figure 01 for NHA)	Ref
2	800921	• Decal, Warning, Do Not Operate at Pressures Exceeding	1
3	800922	• Decal, Warning, Before Opening a Blocked Pipeline,	1
4	86121	• Weldment, Hopper-Standard	1
5	86113	•• Grate, Standard Hopper	1
6	-	•• Bolt, Hex (attaching parts)	A/R
7	-	•• Washer, Lock (attaching parts)	A/R
8	86118	•• Mount, Hopper Grate	2
9	86542	•• Assembly, Rounded Clean Out Door (See Group 20, Figure 03 for DET)	1
10	86083	•• Bumper, Hopper Grate	2
11	85390	• Guard, Splash	1
12	73132	• Decal, REED 4 1/2 Inch	1
13	800931	• Decal, ACPA Member	1
14	800929	• Decal, Warning	2
15	800917	• Decal, Warning, Keep Hand Out of Hopper and Valve	2
16	20-04	• Assembly, Hopper Agitator (See Group 20, Figure 04 for DET)	1
17	20-06	• Assembly, Agitator / Outriggers Control Valve (See Group 20, Figure 06 for DET)	1
18	800919	• Decal, Warning, Stand Clear Outriggers When Activating	2
19	800918	• Decal, Warning, Do Not Stand on Hopper Grate	2

REVISION:



ROUNDED CLEAN OUT DOOR ASSEMBLY

C50HP
PARTS
GROUP 20
FIGURE 02
PAGE 01

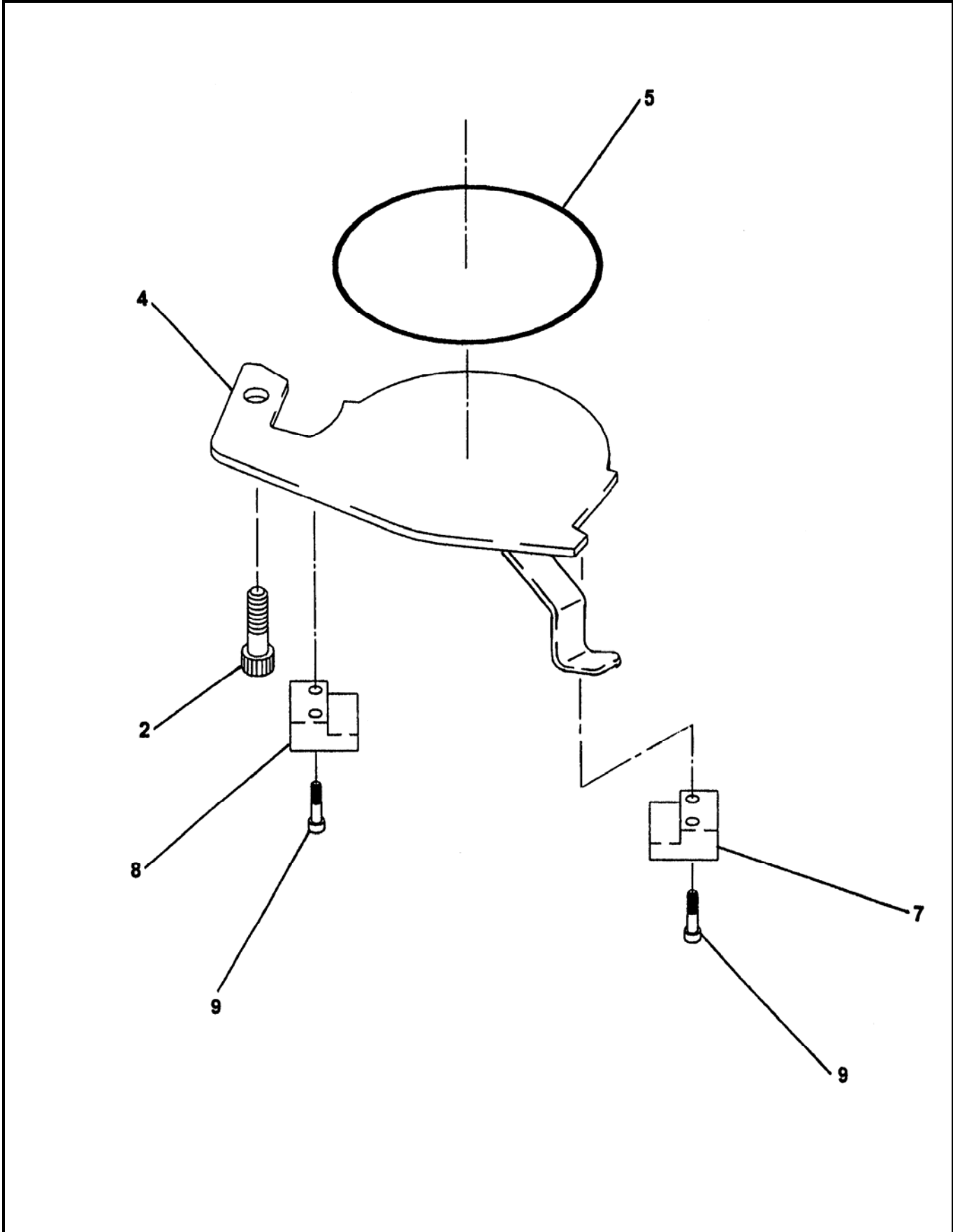

REVISION:



ROUNDED CLEAN OUT DOOR ASSEMBLY

C50HP
PARTS
GROUP 20
FIGURE 02
PAGE 02

ITEM NO.	REED'S PARTS NO.	DESCRIPTION	QTY
		1 2 3 4 5	
-1	86542	Assembly, Rounded Clean Out Door (See Group 20, Figure 01 and Figure 02 for NHA)	Ref
2	86922	• Bolt, Shoulder	1
3	-	• OPEN	-
4	86988	• Door, Weldment Clean-Out	1
5	W-102908A	• Cord, Hopper Door O-Ring 2.21 FT	1
6	-	• OPEN	-
7	86560	• Block, RH Clean Out Door	1
8	86559	• Block, LH Clean Out Door	1
9		• Capscrew, Socket Head	4
-10	85312	• Plate, Seal	1
-11	85371	• Neck, Clean Out Door	1

REVISION:



AGITATOR ASSEMBLY

C50HP
PARTS
GROUP 20
FIGURE 03
PAGE 01

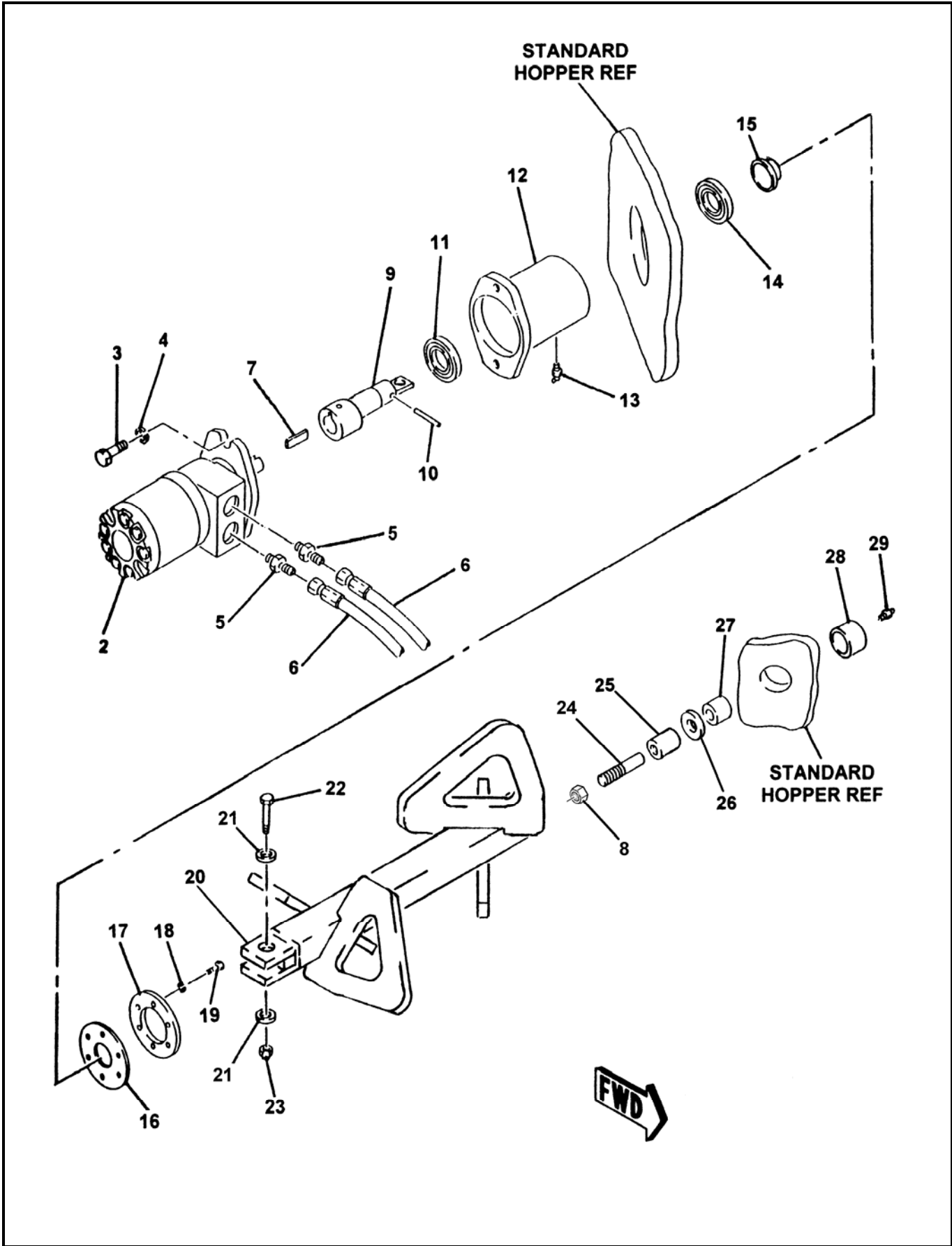

REVISION:



AGITATOR ASSEMBLY

C50HP
PARTS
 GROUP 20
 FIGURE 03
 PAGE 02

ITEM NO.	REED'S PARTS NO.	DESCRIPTION	QTY
		1 2 3 4 5	
-1	86322	Assembly, Standard Hopper Agitator (Optional Item) (See Group 20, Figure 01 for NHA)	Ref
2	85811	• Assembly, Standard Hopper Agitator Motor (See Group 20, Figure 05 for DET)	1
3	-	• Bolt, Hex (attaching parts)	1
4	-	• Washer, Lock (attaching parts)	2
5	-	• Fitting, STR	2
6	85658-002	• Assembly, Hose	2
7	30216	• Key	1
8	80030	• Nut, Lock-Jam 20mm	1
9	85923	• Shaft, Agitator	1
10	86758	• Pin, Spring	1
11	85979	• Bearing, with Seal Ball	1
12	70226	• Housing, Bearing with Flange (Welded on Standard Hopper)	1
13	-	• Fitting, 45° Grease	1
14	85978	• Bearing, Plain Ball	1
15	85976	• Ring, Agitator Wear	1
16	70212	• Seal	1
17	70211	• Flange, Seal	1
18	86743	• Washer, Lock 1/4 (attaching parts)	6
19	86744	• Bolt, Hex 1/4-28 x 3/4 (attaching parts)	6
20	86330	• Weldment, Standard Hopper Agitator Shaft	1
21		• Washer, Flat 1/2 (attaching parts)	2
22	86756	• Screw, Hex Head Cap 1/2-13 x 2 1/2 GR8 (attaching parts)	1
23	80075	• Nut 1/2-13 (attaching parts)	1
24	70214	• Shaft, Idle	1
25	77877	• Spacer	1
26	86186	• Washer	1
27	70219	• Bearing, Idler	1
28	70210	• Housing, Idler Bearing (Welded on Standard Hopper)	1
29		• Fitting, STR Grease	1
-30	85846	• Decal, Agitator	1
DASH (-) ITEM NOT ILLUSTRATED			

REVISION:



AGITATOR MOTOR ASSEMBLY

C50HP
PARTS
GROUP 20
FIGURE 04
PAGE 01

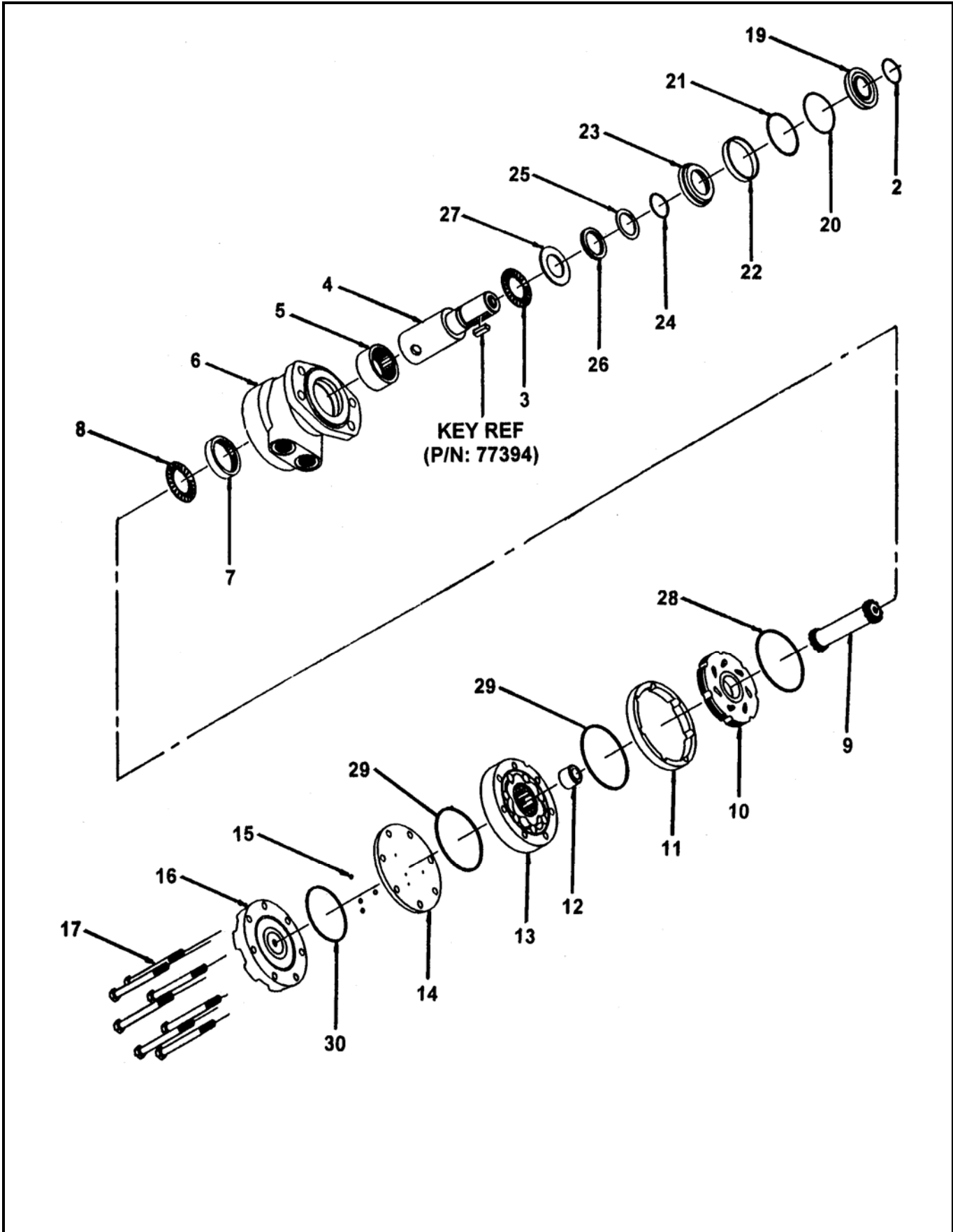

REVISION:



AGITATOR MOTOR ASSEMBLY

C50HP
PARTS
GROUP 20
FIGURE 04
PAGE 02

ITEM NO.	REED'S PARTS NO.	DESCRIPTION	QTY
		1 2 3 4 5	
-1	85811	Assembly, Standard Hopper Agitator Motor (See Group 20, Figure 04 for NHA)	Ref
2		• Ring, Wire	1
3		• Bearing, Front Thrust	1
4		• Kit, Shaft	1
5		• Bearing, Front Housing	1
6		• Kit, Housing	1
7		• Bearing, Rear Housing	1
8		• Bearing, Rear Thrust	1
9		• Kit, Drive Link	1
10		• Bearing, Front Thrust	1
11		• Manifold	1
12		• Boot, Manifold	1
13		• Kit, Free Turn Rotor	1
14		• Plate, Balance	1
15		• Ball, Steel	4
16		• Cover, Motor End	1
17		• Bolt, Hex (attaching parts)	7
-18	85809SK	• Kit, Seal	1
19		•• Seal, Dust	1
20		•• Ring, Split Wire	1
21		•• Shim, Metal Back Up	1
22		•• Seal, High Pressure	1
23		•• Carrier, Seal	1
24		•• Shim, Metal Back Up	1
25		•• Seal, Polyamid	1
26		•• Seal, Shaft	1
27		•• Washer, Thrust	1
28		•• Seal, Rear Housing	1
29		•• Seal, Body	2
30		•• Seal, End Cover	1

DASH (-) ITEM NOT ILLUSTRATED

REVISION:



AGITATOR / OUTRIGGERS CONTROL VALVE ASSEMBLY

C50HP
PARTS
GROUP 20
FIGURE 05
PAGE 01

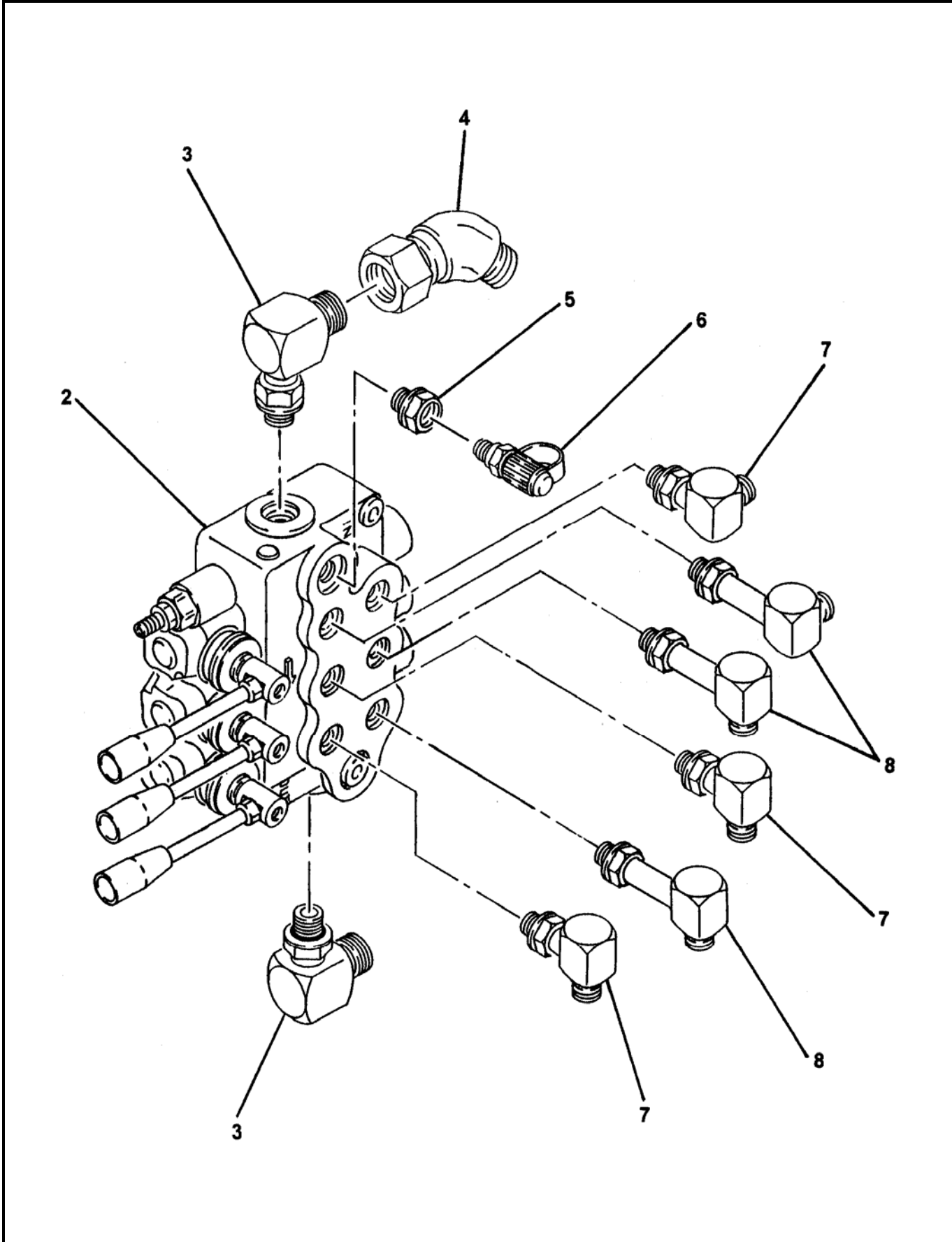

REVISION:



**AGITATOR / OUTRIGGERS
CONTROL VALVE ASSEMBLY**

**C50HP
PARTS
GROUP 20
FIGURE 05
PAGE 02**

ITEM NO.	REED'S PARTS NO.	DESCRIPTION					QTY
		1	2	3	4	5	
-1	20-08	Assembly, 3 Spool Control Valve (See Group 20, Figure 01 and Figure 02 for NHA)					Ref
2	74471	• Sub-Assembly, Agitator Control Valve (See Group 20, Figure 10 for DET)					1
3		• Fitting, 90					2
4		• Swivel, 45					1
5		• Reducer, 8-6					1
6	800083	• Fitting, Mini Check (Port)					1
7		• Fitting, 90					3
8		• Fitting, 90					3
-9		• Bolt, Hex					2
-10		• Washer, SPL Lock					2

DASH (-) ITEM NOT ILLUSTRATED



**AGITATOR / OUTRIGGERS
CONTROL VALVE SUB-ASSEMBLY**

**C50HP
PARTS
GROUP 20
FIGURE 06
PAGE 02**

ITEM NO.	REED'S PARTS NO.	DESCRIPTION	QTY
		1 2 3 4 5	
-1	74471	Sub-Assembly, 3 Spool Control Valve (See Group 20, Figure 08 for NHA)	Ref
2	85706	• Cartridge, Relief	1
3		• • Kit, Screw	1
4		• • Spring	1
5		• • Pin, Screw Kit	1
6		• • Ring	1
7		• • O-Ring	1
8		• O-Ring	4
9		• Kit, Spool Control	3
10		• Cap, Spool	3
11		• Screw, SOC (attaching Parts)	6
12		• Nut	1
13		• Bolt, Hex	1
14		• Kit, VRS	1
15		• Plug	2
16		• Plug	1
17		• Handle, Remixer Valve	3
18		• Nut (attaching parts)	3
19		• Screw, SOC	6
20		• Lever, L	3
21		• Spool	3
22		• Body, Valve	1

DASH (-) ITEM NOT ILLUSTRATED

REVISION:



**C50HPS TRAILER MOUNTED PUMP
GROUP 20 HOPPER INSTALLATION**

**C50HP
PARTS
GROUP 20
FIGURE 07
PAGE 01**

THIS PAGE INTENTIONALLY LEFT BLANK.

REED TRAILER MOUNTED CONCRETE PUMP 02 MODEL C50HP ILLUSTRATED PARTS MANUAL GROUP 30 HYDRAULIC TANK INSTALLATION CONTAINS THE FOLLOWING FIGURES:

- FIGURE 00** TABLE OF CONTENTS
- FIGURE 01** TANK INSTALLATION
- FIGURE 02** HYDRAULIC TANK ASSEMBLY
- FIGURE 03** ACCUMULATOR ASSEMBLY
- FIGURE 04** ACCUMULATOR BLADDER REPAIR KIT
- FIGURE 05** SWING TUBE CIRCUIT MANIFOLD ASSEMBLY
- FIGURE 06** SWING TUBE CIRCUIT MAIN SOLENOID VALVE ASSEMBLY
- FIGURE 07** SWING TUBE CIRCUIT PILOT SOLENOID VALVE ASSEMBLY
- FIGURE 08** BALL VALVE ASSEMBLY

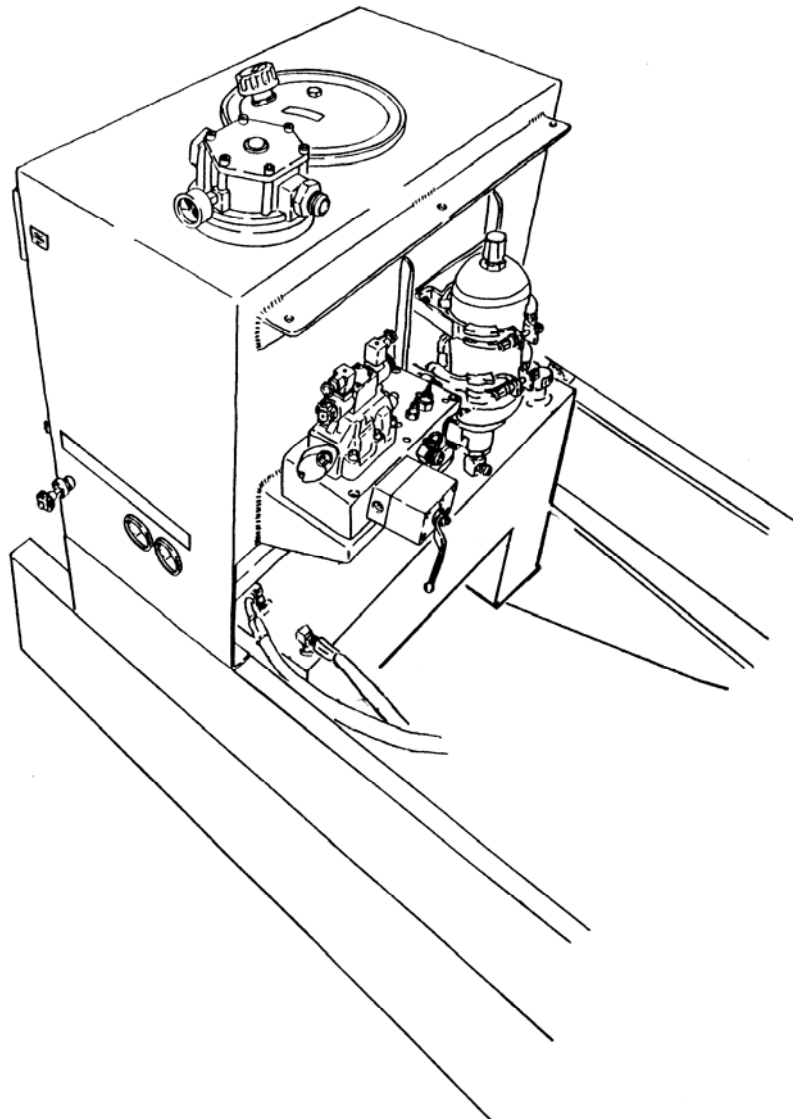



TANK INSTALLATION

C50HP
PARTS
GROUP 30
FIGURE 01
PAGE 01

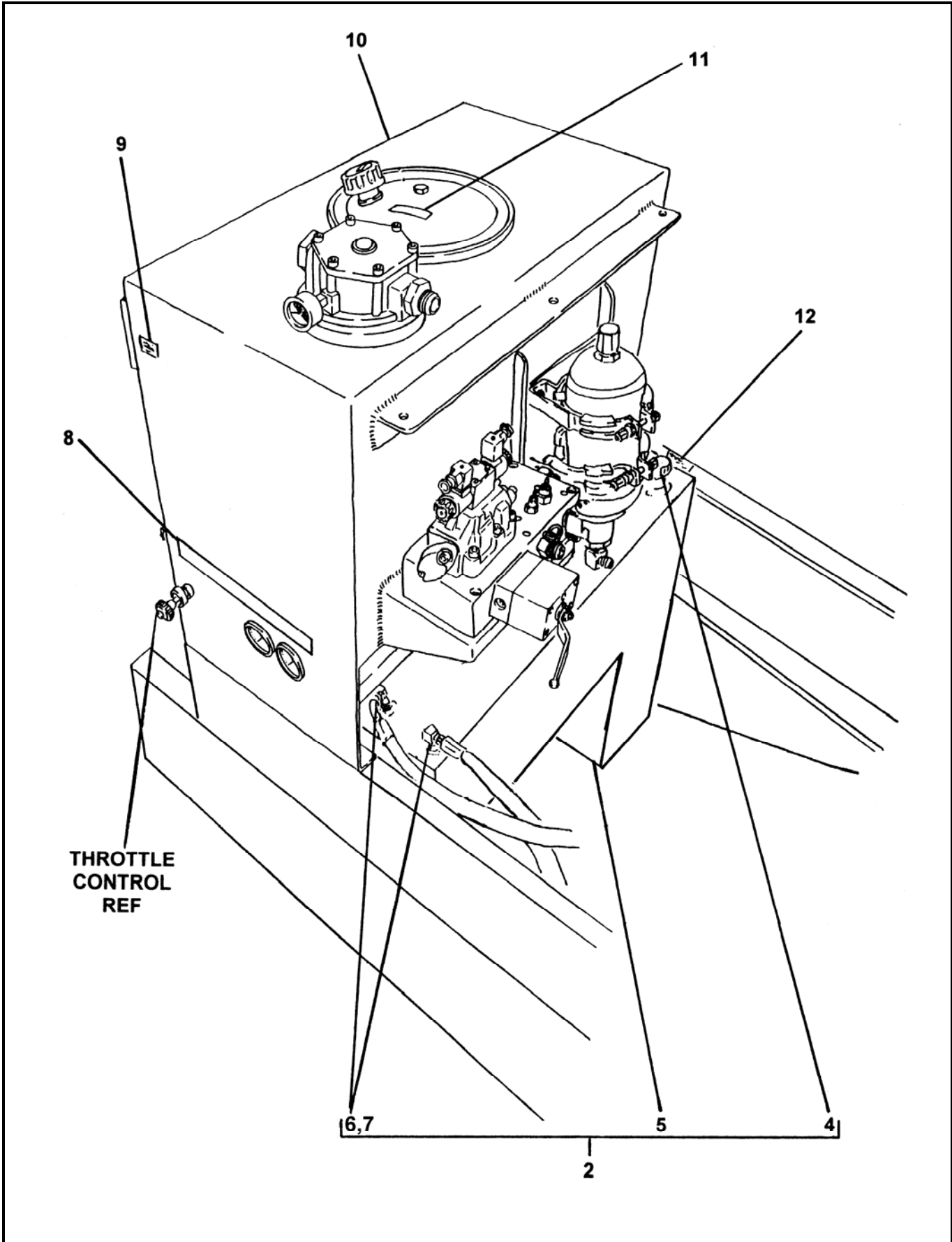

REVISION:



TANK INSTALLATION

C50HP
PARTS
GROUP 30
FIGURE 01
PAGE 02

ITEM NO.	REED'S PARTS NO.	DESCRIPTION	QTY
		1 2 3 4 5	
-1	30-01	Installation, Tank (See Group 10, Figure 01 for NHA)	Ref
2	85437	• Assembly, Fuel Tank	1
-3	77191	•• Gauge, Fuel	1
4	85570	•• Cap, Fuel	1
5	77181	•• Weldment, Fuel Tank	1
6	77183	•• Assembly, Fuel Pick-Up Tube (Screws into Tank)	2
7		•• Elbow, 90	2
8	85684	• Decal, Gauge	1
9	85844	• Decal, Oil Level	1
10	85431	• Assembly, Hydraulic Tank (See Group 30, Figure 02 for DET)	1
-11	75020	• Decal, Hydraulic Oil	2
-12	86366	• Kit, C50HP Hose (See SCHEMATIC Section for DET)	1
		DASH ITEM (-) NOT ILLUSTRATED	

REVISION:



HYDRAULIC TANK ASSEMBLY

C50HP
PARTS
GROUP 30
FIGURE 02
PAGE 01

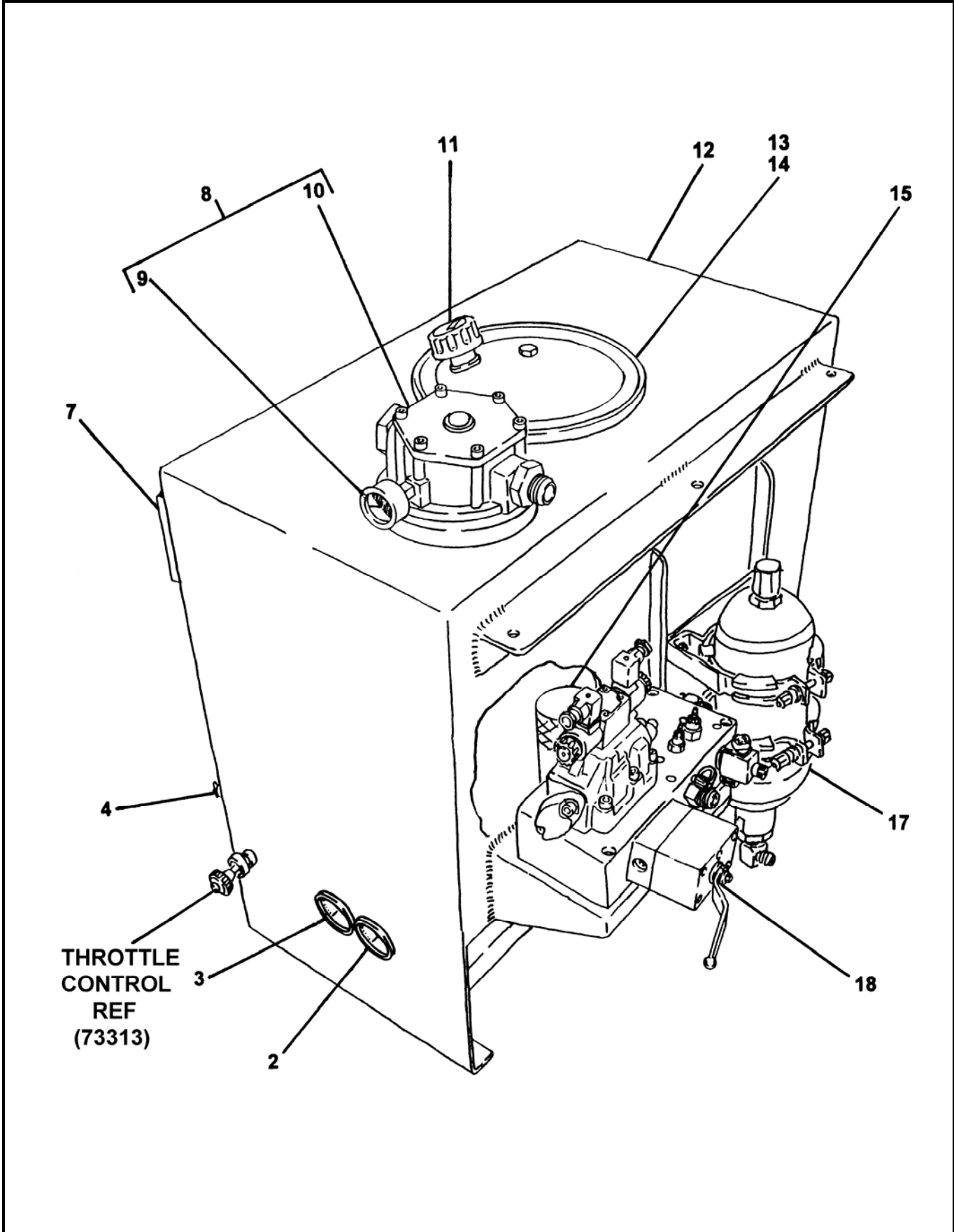

REVISION:



HYDRAULIC TANK ASSEMBLY

C50HP
PARTS
GROUP 30
FIGURE 02
PAGE 02

ITEM NO.	REED'S PARTS NO.	DESCRIPTION	QTY
		1 2 3 4 5	
-1	85431	Assembly, Hydraulic Tank (See Group 30, Figure 01 for NHA)	Ref
2	70366	• Gauge, 3,000 PSI Hydraulic	1
3	74562	• Gauge, 6,000 PSI Hydraulic	1
4	801025	• Cock, Drain	1
7	74509	• Gauge, Sight	1
8	85282	• Filter, Return	1
9	85575	• • Gauge, Return Filter	1
10	85283	• • Element, Return Filter	1
11	85537	• Filler, Breather	1
12	85360	• Weldment, Hydraulic Tank	1
13	85529	• • End Cover, Hydraulic Tank	1
14	85867	• • Gasket, End Cover	1
15	79247	• Separator, Magnetic	1
-16	77282	• Valve, Check	1
17	30-03	• Assembly, Accumulator (See Group 30, Figure 03 for DET)	1
18	85249	• Assembly, Swing Tube Circuit Manifold (See Group 30, Figure 05 for DET)	1
-19	78598	• Plug, Hoffman	A/R
		DASH (-) ITEM NOT ILLUSTRATED	

REVISION:



ACCUMULATOR ASSEMBLY

C50HP
PARTS
GROUP 30
FIGURE 03
PAGE 01

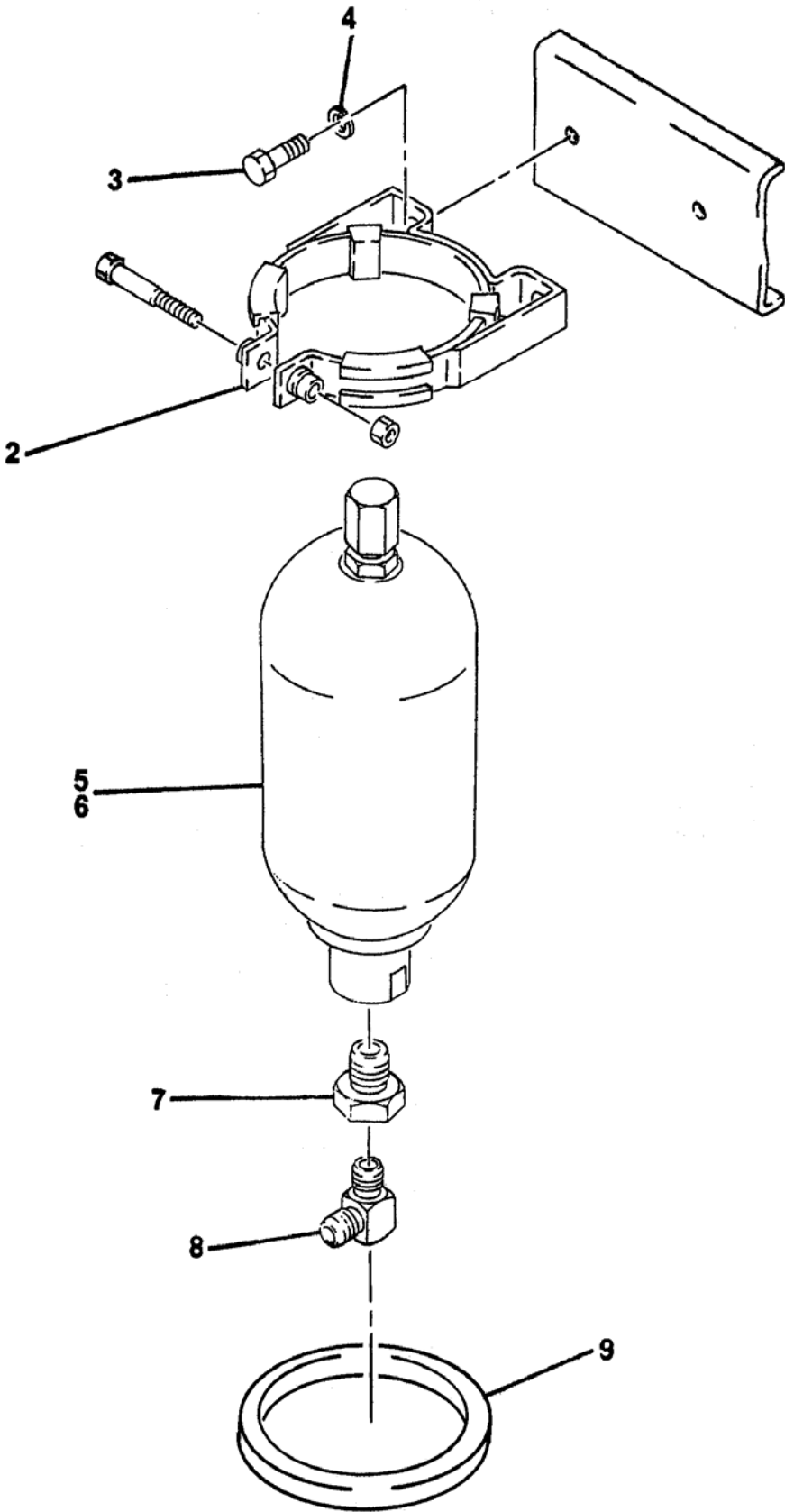

REVISION:



ACCUMULATOR ASSEMBLY

C50HP
PARTS
GROUP 30
FIGURE 03
PAGE 02

ITEM NO.	REED'S PARTS NO.	DESCRIPTION	QTY
		1 2 3 4 5	
-1	30-03	Assembly, Accumulator (See Group 30, Figure 01 for NHA)	Ref
2	73171	• Bracket, Accumulator	1
3		• Bolt, Hex (attaching parts)	2
4		• Washer, Lock (attaching parts)	2
5	74515	• Accumulator, 1 Gal	1
6	30-04	• Kit, Bladder Repair (See Group 30, Figure 04 for DET)	1
7		• Reducer	1
8		• Elbow, 90	1
9	801028	• Grommet, Accumulator	1
-10	71460	• Kit, Accumulator Charge (See Group 80, Figure 07 for REF)	Ref

DASH (-) ITEM NOT ILLUSTRATED



ACCUMULATOR BLADDER REPAIR KIT

C50HP
PARTS
GROUP 30
FIGURE 04
PAGE 01

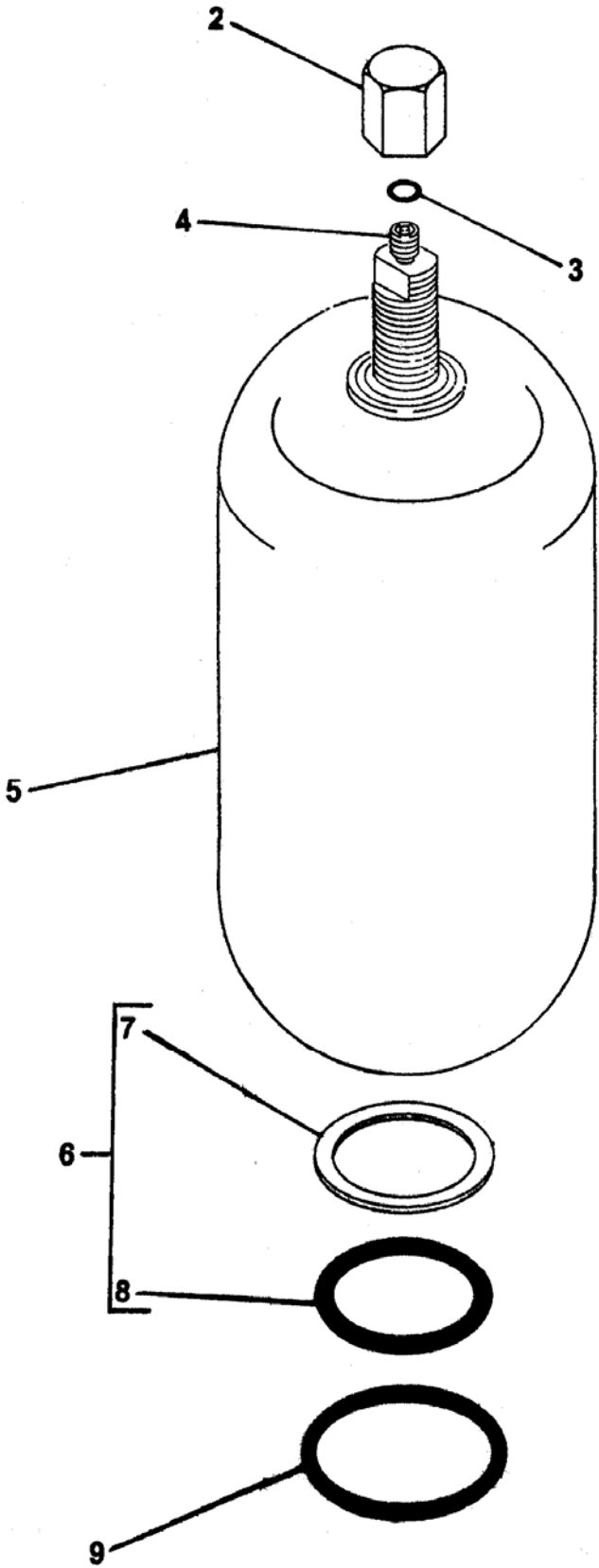

REVISION:



ACCUMULATOR BLADDER REPAIR KIT

C50HP
PARTS
GROUP 30
FIGURE 04
PAGE 02

ITEM NO.	REED'S PARTS NO.	DESCRIPTION	QTY
		1 2 3 4 5	
-1	30-04	Kit, Bladder Repair (Also See Group 30, Figure 03 for NHA)	Ref
2		• Cap, Valve Seal	1
3		• O-Ring	1
4		• Core, Gas Valve	1
5	74516	• Bladder, 1 Gal	1
6	85812	• Kit, Bladder Seal	1
7		• • Ring, Flat	1
8		• • O-Ring	1
9		• Ring, Back Up	1

DASH (-) ITEM NOT ILLUSTRATED

REVISION:



SWING TUBE CIRCUIT MANIFOLD ASSEMBLY

C50HP
PARTS
GROUP 30
FIGURE 05
PAGE 01

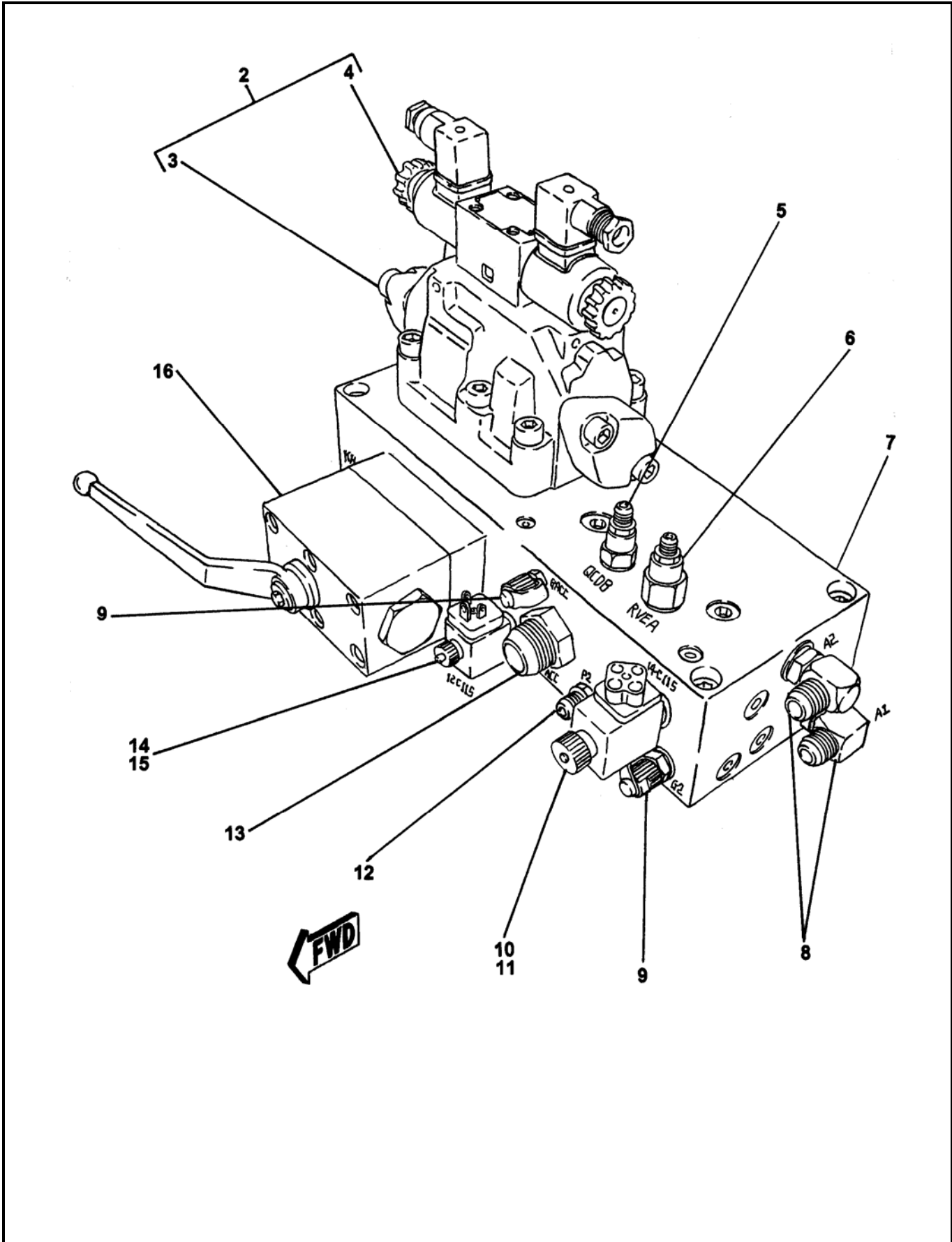

REVISION:



SWING TUBE CIRCUIT MANIFOLD ASSEMBLY

C50HP
PARTS
GROUP 30
FIGURE 05
PAGE 02

ITEM NO.	REED'S PARTS NO.	DESCRIPTION	QTY
		1 2 3 4 5	
-1	85249	Assembly, Swing Tube Circuit Manifold (See Group 30, Figure 02 for NHA)	Ref
2	85693	• Assembly, Swing Tube Circuit Solenoid Valve	1
3	85694	• • Assembly, Swing Tube Circuit Main Solenoid Valve (See Group 30, Figure 06 for DET)	1
4	85695	• • Assembly, Swing Tube Circuit Pilot Solenoid Valve (See Group 30, Figure 07 for DET)	1
5	85704	• Cartridge, Unloader Valve	1
6	85703	• Cartridge, Relief Valve	1
7		• Body, Swing Tube Circuit Manifold	1
8		• Elbow, 90	2
9	78593	• Port, Mini Check	2
10	85701	• Cartridge, SV4 Solenoid Valve	1
11	85702	• • Coil, SV4 Solenoid Valve Cartridge	1
12		• Fitting, STR	1
13		• Fitting, STR	1
14	85699	• Cartridge, SV3 Solenoid Valve	1
15	85700	• • Coil, SV3 Solenoid Valve Cartridge	1
16	85705	• Assembly, Ball Valve (See Group 30, Figure 08 for DET)	1

DASH (-) ITEM NOT ILLUSTRATED

REVISION:



SWING TUBE CIRCUIT MAIN SOLENOID VALVE ASSEMBLY

C50HP
PARTS
GROUP 30
FIGURE 06
PAGE 01

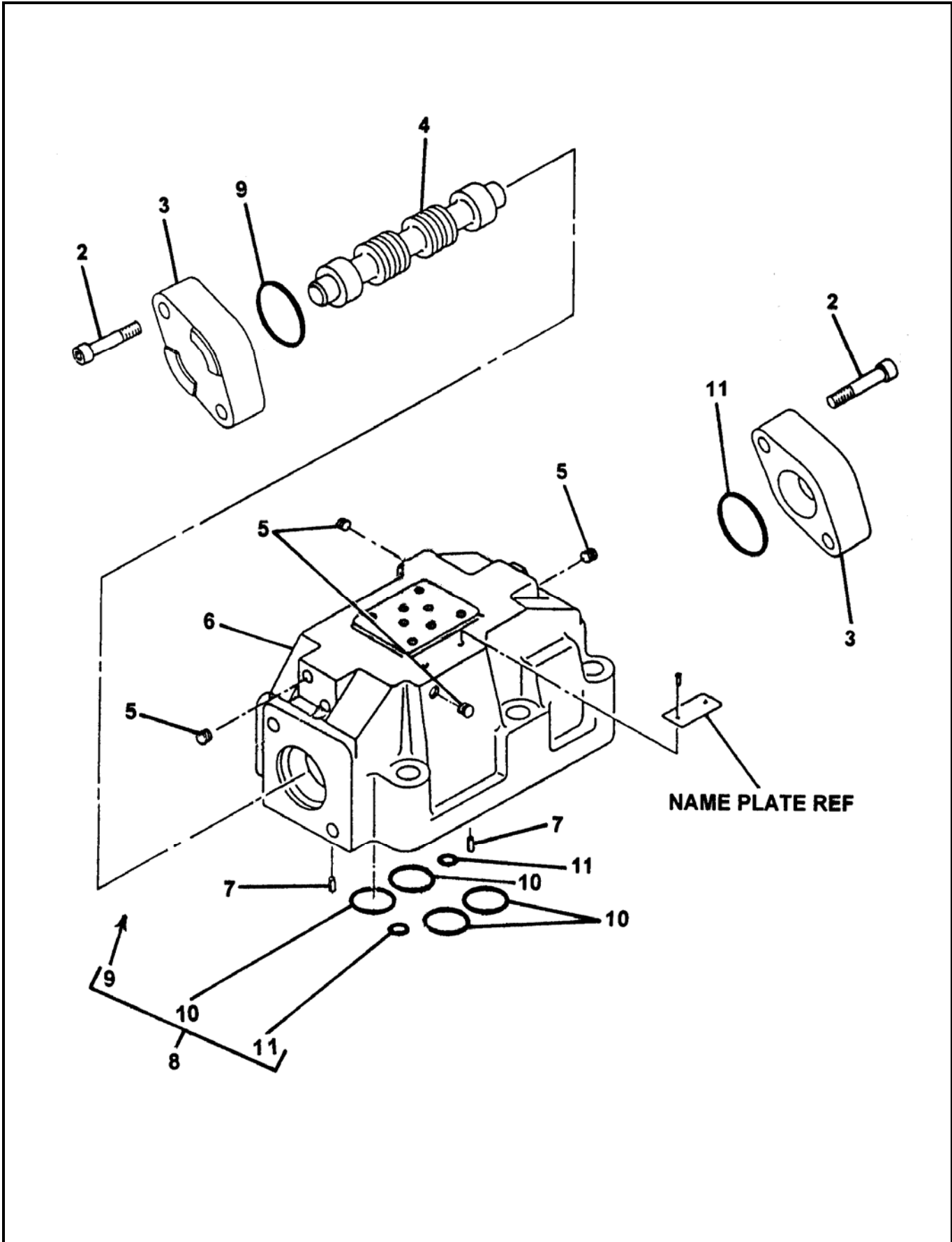

REVISION:



**SWING TUBE CIRCUIT
MAIN SOLENOID VALVE ASSEMBLY**

**C50HP
PARTS
GROUP 30
FIGURE 06
PAGE 02**

ITEM NO.	REED'S PARTS NO.	DESCRIPTION	QTY
		1 2 3 4 5	
-1	85694	Assembly, Swing Tube Circuit Main Solenoid Valve (See Group 30, Figure 05 for NHA)	Ref
2		• Screw, SOC	4
3		• Cover	2
4		• Spool	1
5		• Plug	4
6		• Housing, Cartridge	1
7		• Pin, Grooved	2
8	74994	• Kit, Seal	1
9		•• O-Ring	2
10		•• O-Ring	4
11		•• O-Ring	2

DASH (-) ITEM NOT ILLUSTRATED

REVISION:



SWING TUBE CIRCUIT PILOT SOLENOID VALVE ASSEMBLY

C50HP
PARTS
GROUP 30
FIGURE 07
PAGE 01

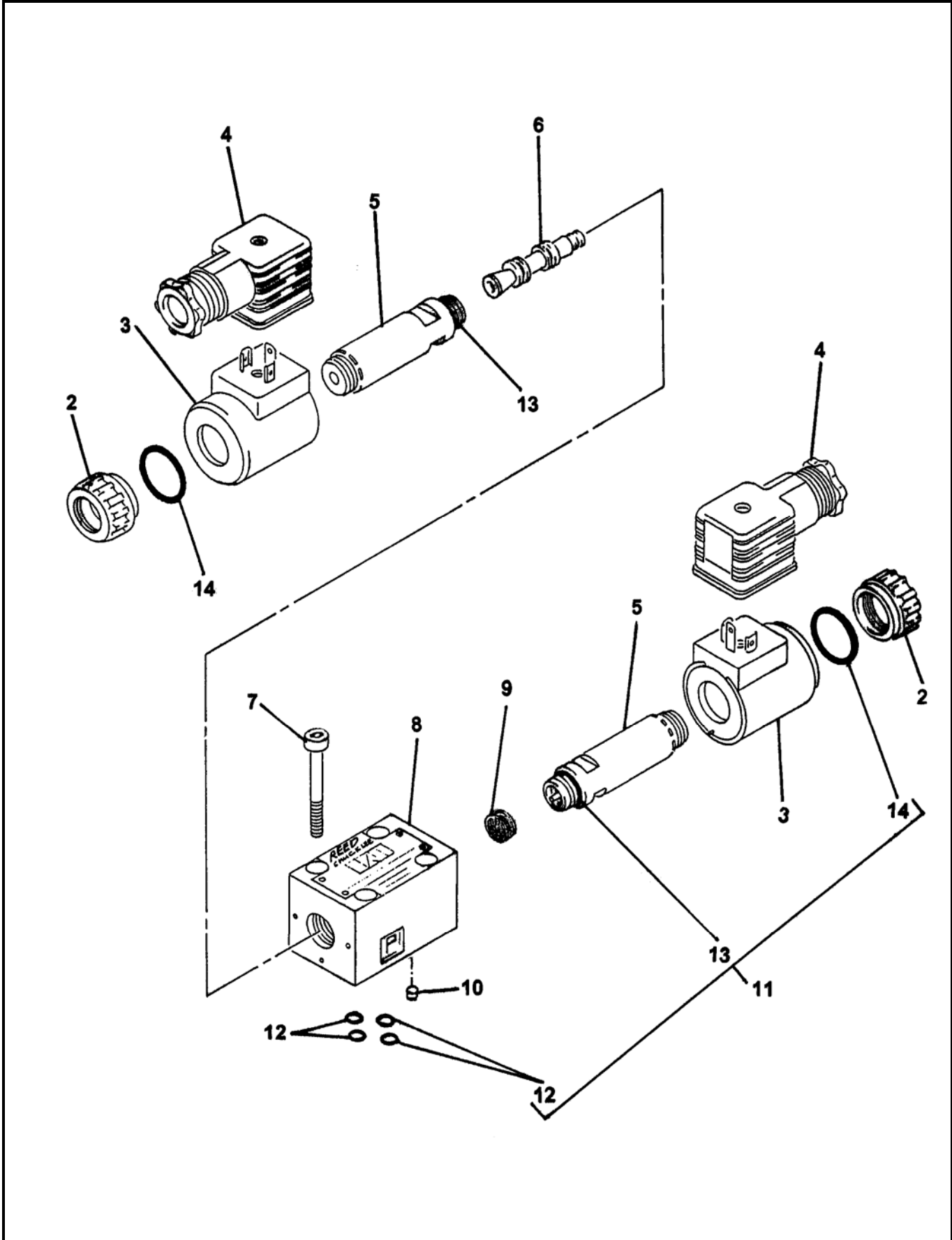

REVISION:



SWING TUBE CIRCUIT PILOT SOLENOID VALVE ASSEMBLY

C50HP
PARTS
GROUP 30
FIGURE 07
PAGE 02

ITEM NO.	REED'S PARTS NO.	DESCRIPTION	QTY
		1 2 3 4 5	
-1	85695	Assembly, Swing Tube Circuit Pilot Solenoid Valve (See Group 30, Figure 05 for NHA)	Ref
2		• Cap, Coil	2
3	85692	• Coil, Solenoid	2
4	74597	• Connector, Plug	2
5	74544	• Amature W/Coil	2
6		• Spool	1
7		• Screw, SOC	4
8		• Housing, Solenoid Valve	1
9		• Detent	1
10		• Orifice	1
11	72313	• Kit, O-ring	1
12		• • O-Ring	4
13		• • O-ring	2
14		• • O-ring	2
		DASH (-) ITEM NOT ILLUSTRATED	

REVISION:



BALL VALVE ASSEMBLY

C50HP
PARTS
GROUP 30
FIGURE 08
PAGE 01

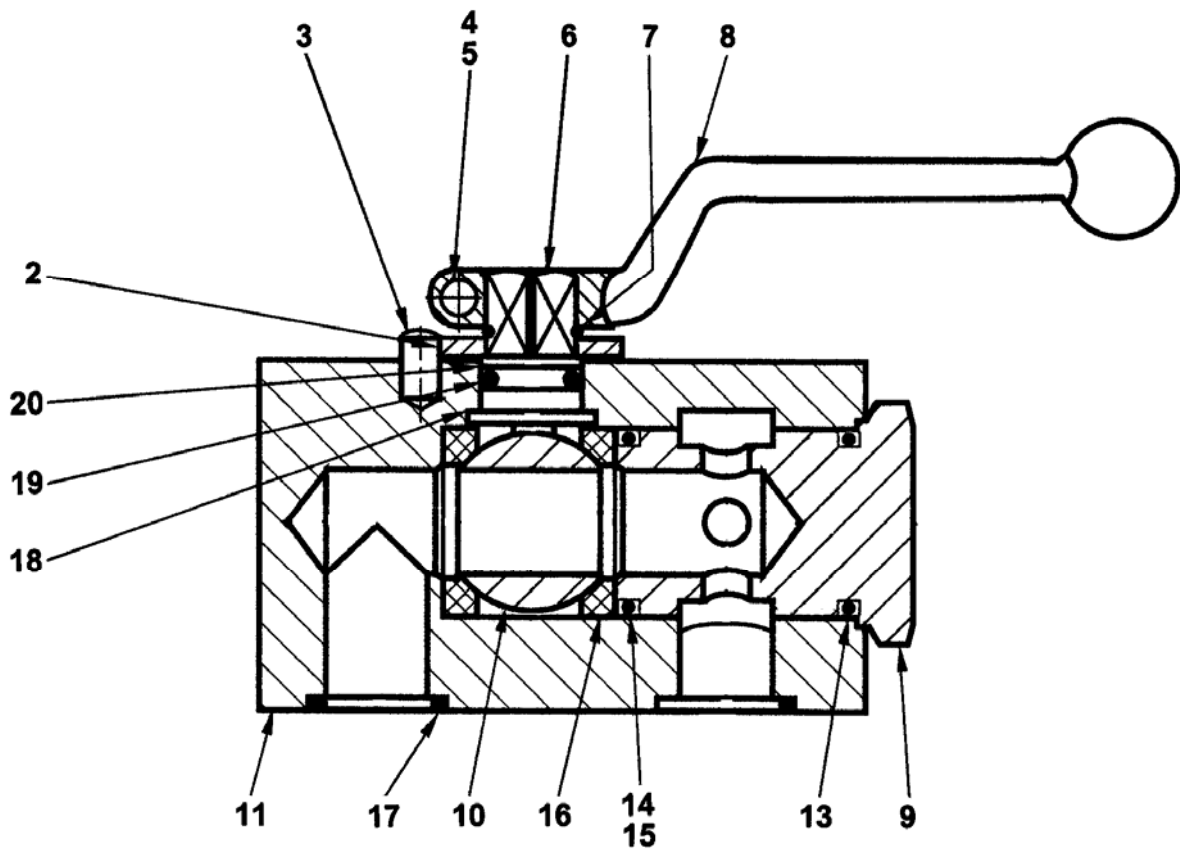

REVISION:



BALL VALVE ASSEMBLY

C50HP
PARTS
GROUP 30
FIGURE 08
PAGE 02

ITEM NO.	REED'S PARTS NO.	DESCRIPTION	QTY
		1 2 3 4 5	
-1	85705	Assembly, Ball Valve (See Group 30, Figure 05 for NHA)	Ref
2		• Washer, Limit	1
3		• Pin, Stop	1
4		• Bolt, Hex	1
5		• Nut, Hex	1
6		• Handle, Control	1
7		• Spindle, Control	1
8		• Retainer, Spring	1
9		• Plug	1
10		• Ball	1
11		• Housing	1
-12		• Kit, Seal	1
13		• • O-Ring	1
14		• • O-Ring	1
15		• • Ring, Back Up	1
16		• • Seal, Bowl	2
17		• • O-Ring	1
18		• • Washer, Thrust	1
19		• • O-Ring	1
20		• • Ring, Back Up	1

DASH (-) ITEM NOT ILLUSTRATED



**C50HPS TRAILER MOUNTED PUMP
GROUP 30 TANK INSTALLATION**

**C50HP
PARTS
GROUP 30
FIGURE 09
PAGE 01**

THIS PAGE INTENTIONALLY LEFT BLANK.



REED TRAILER MOUNTED CONCRETE PUMP 02 MODEL C50HP ILLUSTRATED PARTS MANUAL GROUP 40 POWER TRAIN INSTALLATION CONTAINS THE FOLLOWING FIGURES:

FIGURE 00	TABLE OF CONTENTS
FIGURE 01	POWER TRAIN INSTALLATION
FIGURE 02	POWER TRAIN ASSEMBLY
FIGURE 02	HYDRAULIC PUMPS ASSEMBLY
FIGURE 03	DOUBLE AUXILIARY PUMP ASSEMBLY
FIGURE 04	SINGLE AUXILIARY PUMP ASSEMBLY
FIGURE 05	HOT OIL SHUTTLE ASSEMBLY
FIGURE 06	MAIN HYDRAULIC PUMP ASSEMBLY
FIGURE 07	BATTERY MOUNTING ASSEMBLY



POWER TRAIN INSTALLATION

C50HP
PARTS
GROUP 40
FIGURE 01
PAGE 01

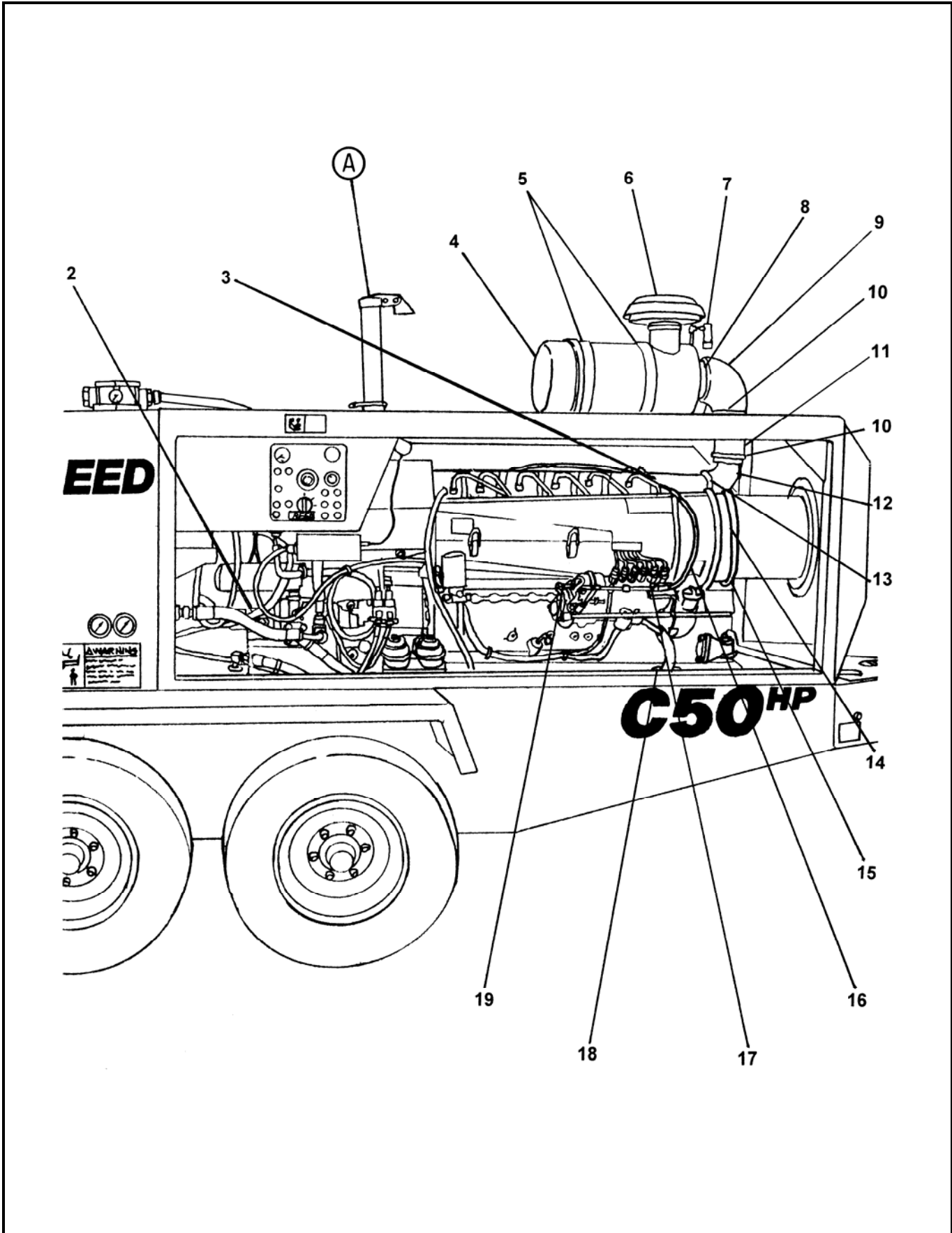

REVISION:



POWER TRAIN INSTALLATION

C50HP
PARTS
 GROUP 40
 FIGURE 01
 PAGE 02

ITEM NO.	REED'S PARTS NO.	DESCRIPTION	QTY
		1 2 3 4 5	
-1	40-01	Installation, Power Train (See Group 10, Figure 01 and Figure 02 for NHA)	Ref
2	86300	• Assembly, Power Train (Engine-PN 71150) (See Group 40, Figure 02 for DET)	1
3	77486	• Sleeve, Intake	1
4	73485	• Cleaner, Air	1
-4A	73584	• Element, Air Cleaner	1
5	77343	• Clamp, Air Cleaner Mount	2
6	73486	• Hood, Air Cleaner	1
7	78298	• Indicator, Vacuum gauge	1
8	78300	• Clamp	1
9	73487	• Elbow, Rubber	1
10	77477	• Clamp, T-Bolt	2
11	86111	• Tube, Air Intake	1
-11A	85876	• Tube, Air Intake	1
12	73479	• Elbow	1
13	73532	• Clamp, T-Bolt	3
14	85433	• Ring, Air Intake	1
15	85422	• Ring, Air Guide Brush	1
16	73313	• Cable, Throttle Control	1
17	71009	• U-Clip, Throttle Cable	1
18	76951	• Filter, Water Separator	1
-18A	79794	• • Element, Water Separator Filter	
19	71020	• Ends, Yoke	1
20	73475	• Cap, Rain	1
21	86495	• Elbow, Exhaust	1
22	77258	• Clamp	2
23	73426	• Reducer, Exhaust Pipe	1
24	85399	• Assembly, Engine Wiring Harness (See Schematic Section for REF)	1
25	40-07	• Assembly, Battery Mounting (See Group 40, Figure 07 for DET)	1
-26	85669-002	• Hose	1
-27	85881	• Support, Belt Guard	1
-28	85882	• Guard, Belt	1
-29	87087	• Mount, Engine Spacer	6
-30	10277	• Clamp, Fuel Hose	2
-31	77347A	• Assembly, 8 FT Hose	1
-32	800080	• Hose, Minicheck-72"	1
-33	86265-002	• Split Flange-Code 62-16 SAE	2
-34	86912-004	• Flange	2
DASH (-) ITEM NOT ILLUSTRATED			

REVISION:



POWER TRAIN INSTALLATION

C50HP
PARTS
GROUP 40
FIGURE 01
PAGE 03

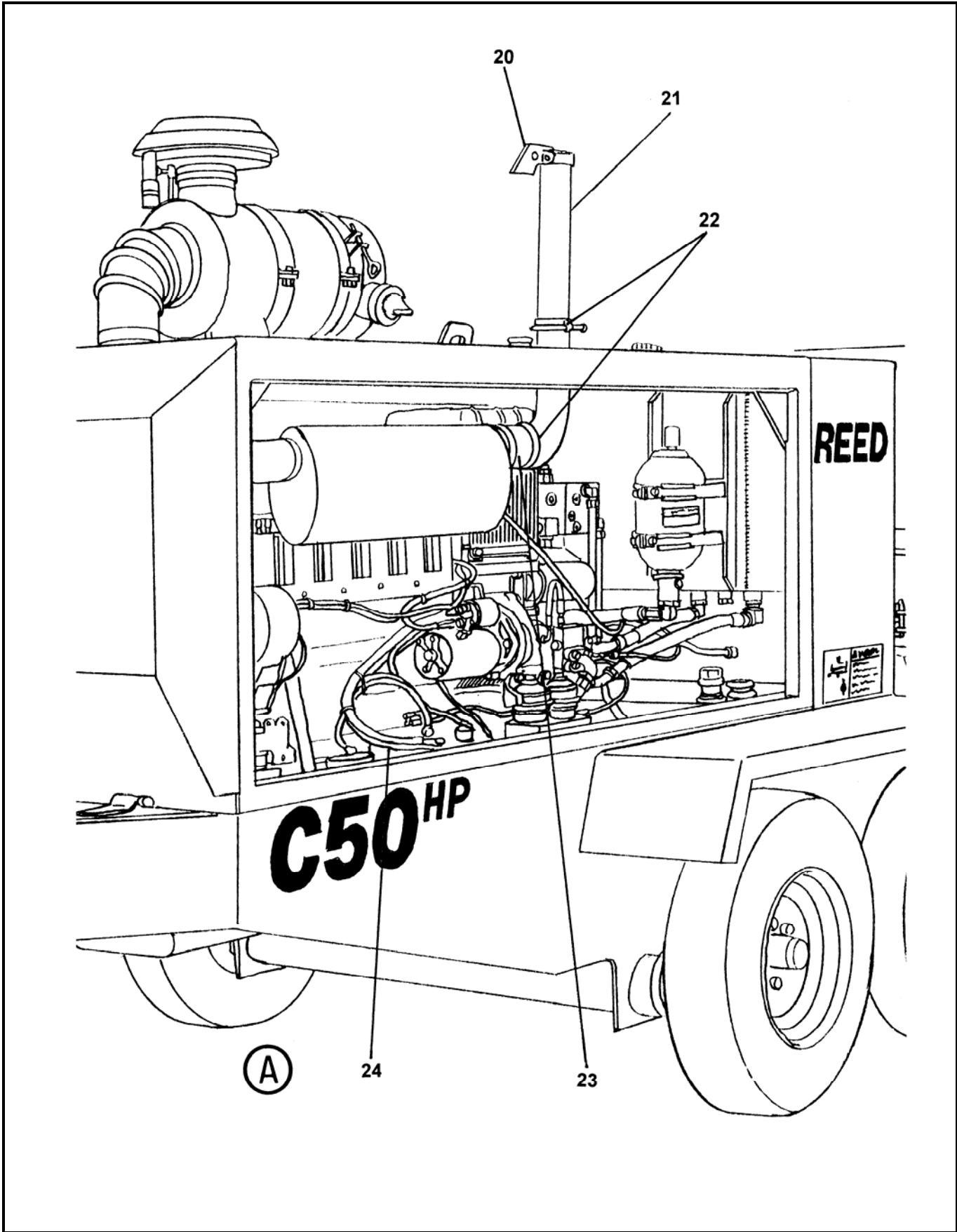

REVISION:



POWER TRAIN INSTALLATION

C50HP
PARTS
 GROUP 40
 FIGURE 01
 PAGE 04

ITEM NO.	REED'S PARTS NO.	DESCRIPTION	QTY
		1 2 3 4 5	
-1	40-01	Installation, Power Train (See Group 10, Figure 01 and Figure 02 for NHA)	Ref
2	86300	• Assembly, Power Train (Engine-PN 71150) (See Group 40, Figure 02 for DET)	1
3	77486	• Sleeve, Intake	1
4	73485	• Cleaner, Air	1
-4A	73584	• Element, Air Cleaner	1
5	77343	• Clamp, Air Cleaner Mount	2
6	73486	• Hood, Air Cleaner	1
7	78298	• Indicator, Vacuum gauge	1
8	78300	• Clamp	1
9	73487	• Elbow, Rubber	1
10	77477	• Clamp, T-Bolt	2
11	86111	• Tube, Air Intake	1
-11A	85876	• Tube, Air Intake	1
12	73479	• Elbow	1
13	73532	• Clamp, T-Bolt	3
14	85433	• Ring, Air Intake	1
15	85422	• Ring, Air Guide Brush	1
16	73313	• Cable, Throttle Control	1
17	71009	• U-Clip, Throttle Cable	1
18	76951	• Filter, Water Separator	1
-18A	79794	• • Element, Water Separator Filter	
19	71020	• Ends, Yoke	1
20	73475	• Cap, Rain	1
21	86495	• Elbow, Exhaust	1
22	77258	• Clamp	2
23	73426	• Reducer, Exhaust Pipe	1
24	85399	• Assembly, Engine Wiring Harness (See Schematic Section for REF)	1
25	40-07	• Assembly, Battery Mounting (See Group 40, Figure 07 for DET)	1
-26	85669-002	• Hose	1
-27	85881	• Support, Belt Guard	1
-28	85882	• Guard, Belt	1
-29	87087	• Mount, Engine Spacer	6
-30	10277	• Clamp, Fuel Hose	2
-31	77347A	• Assembly, 8 FT Hose	1
-32	800080	• Hose, Minicheck-72"	1
-33	86265-002	• Split Flange-Code 62-16 SAE	2
-34	86912-004	• Flange	2
DASH (-) ITEM NOT ILLUSTRATED			

REVISION:



POWER TRAIN ASSEMBLY

C50HP
PARTS
GROUP 40
FIGURE 02
PAGE 01

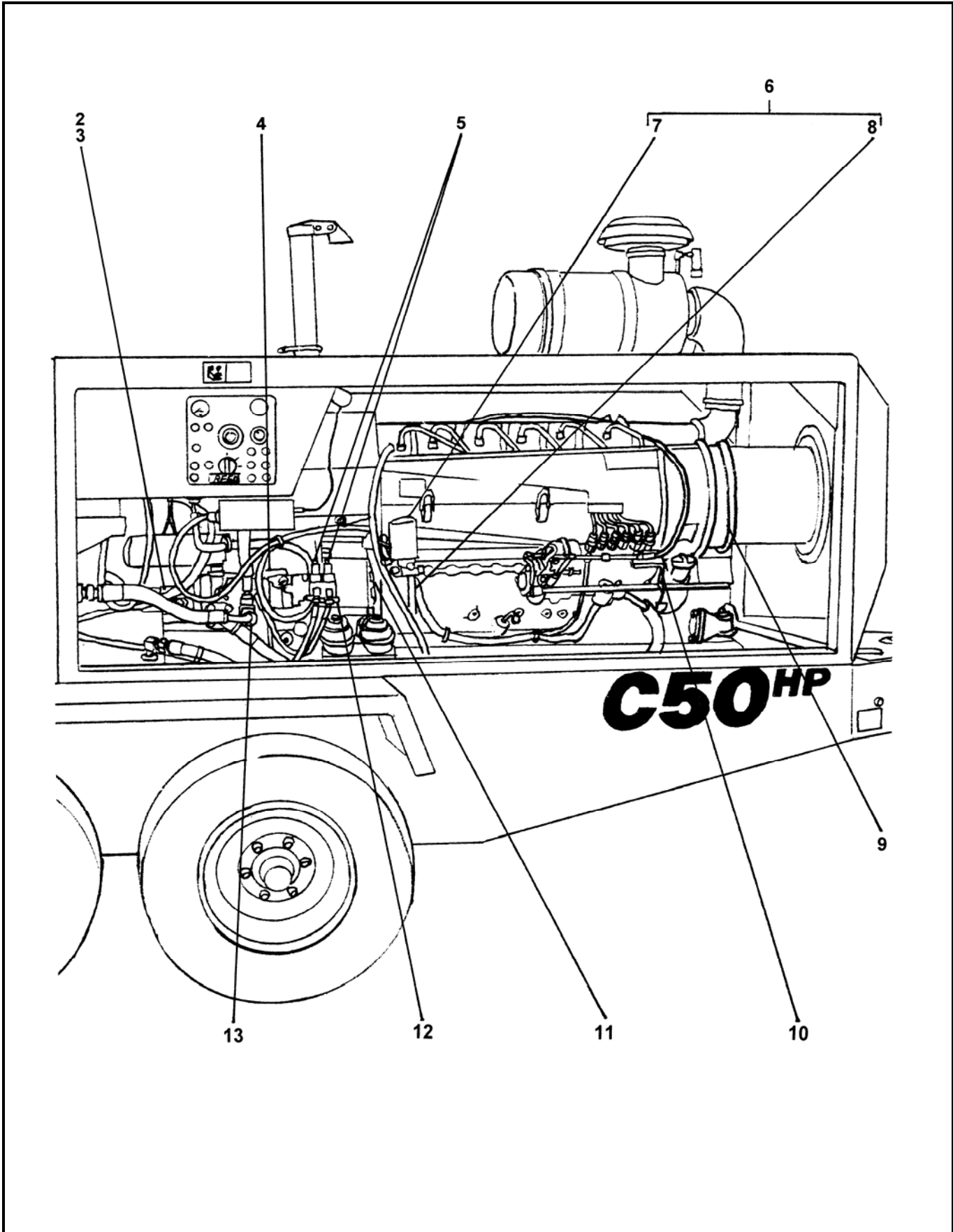

REVISION:



POWER TRAIN ASSEMBLY

C50HP
PARTS
 GROUP 40
 FIGURE 02
 PAGE 02

ITEM NO.	REED'S PARTS NO.	DESCRIPTION	QTY
		1 2 3 4 5	
-1	86300	Assembly, Power Train (See Group 40, Figure 01 for NHA)	Ref
2	87153	• Assembly, Double Auxiliary Pump (See Group 40, Figure 03 for DET)	1
3	87013	• Assembly, Single Auxiliary Pump (Optional Item) (See Group 40, Figure 04 for NHA)	1
4	72980	• Assembly, Hot Oil Shuttle (See Group 40, Figure 05 for DET)	1
5	800074	• Limiter, Remote Pressure	2
6	71150	• Assembly, C50HP Deutz Engine (See Vendor Section, Figure 01 for REF)	1
7	74501	• • Element, Fuel Filter	1
8	71156	• • Element, Engine Oil Filter	1
9	76923	• Ring, Air Brush	1
10	86955	• Bracket, Throttle	1
11	73948	• Assembly, Flywheel Coupling	1
12	72128	• Bracket, Remote Pressure Limiter	1
13	75864	• Assembly, C50HP Main Pump (See Group 40, Figure 06 for DET) (Also See Vendor Section, Figure 02 for REF)	1
-14	85887	• Valve, Shuttle	1
-15	86080	• Bracket, Shuttle Valve	1
-16	800083	• Adaptor, Minicheck	1
-17	86748	• Fitting	3
-18	86900-005	• Adaptor	1
DASH (-) ITEM NOT ILLUSTRATED			

REVISION:



DOUBLE AUXILIARY PUMP ASSEMBLY

C50HP
PARTS
GROUP 40
FIGURE 03
PAGE 01

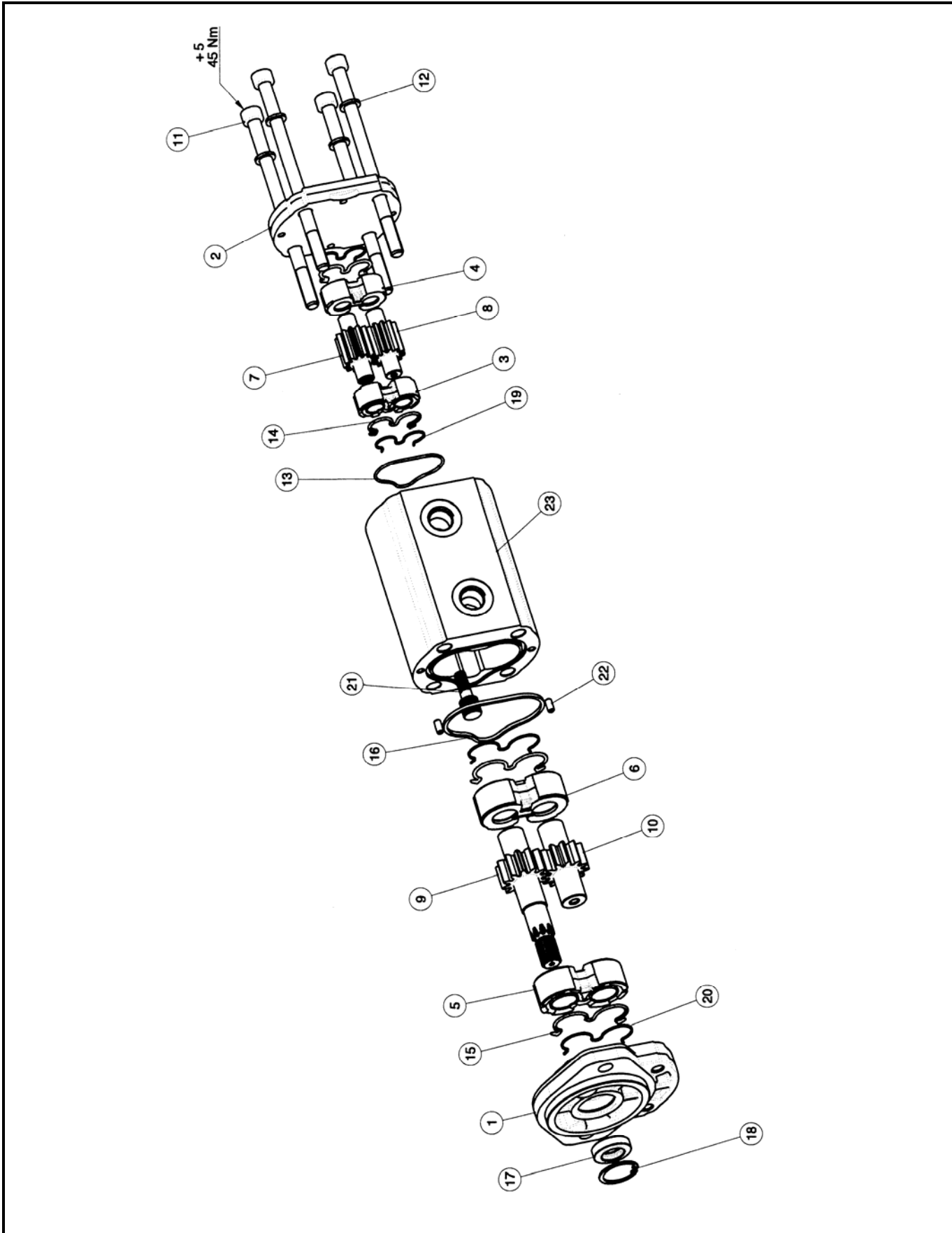

REVISION:



DOUBLE AUXILIARY PUMP ASSEMBLY

C50HP
PARTS
GROUP 40
FIGURE 03
PAGE 02

ITEM NO.	REED'S PARTS NO.	DESCRIPTION	QTY
		1 2 3 4 5	
	87153	Assembly Double Auxiliary Pump (See Group 40, Figure 02 for NHA)	Ref
1		• Cover, Front	1
2		• Cover, Twin Rear	1
3		• Plate, Thrust	1
4		• Plate, Thrust	1
5		• Plate, Thrust	1
6		• Plate, Thrust	1
7		• Gear, Drive	1
8		• Gear, Driven	1
9		• Shaft, Drive	1
10		• Gear, Driven	1
11		• Screw	4
12		• Washer	4
13		• O-Ring	1
14		• Plate, Seal	2
15		• Plate, Seal	2
16		• Plate, Seal	1
17		• Seal, Shaft	1
18		• Ring	1
19		• Plate, Anti-Intrusion	2
		DASH (-) ITEM NOT ILLUSTRATED	

REVISION:



SINGLE AUXILIARY PUMP ASSEMBLY

C50HP
PARTS
GROUP 40
FIGURE 04
PAGE 01

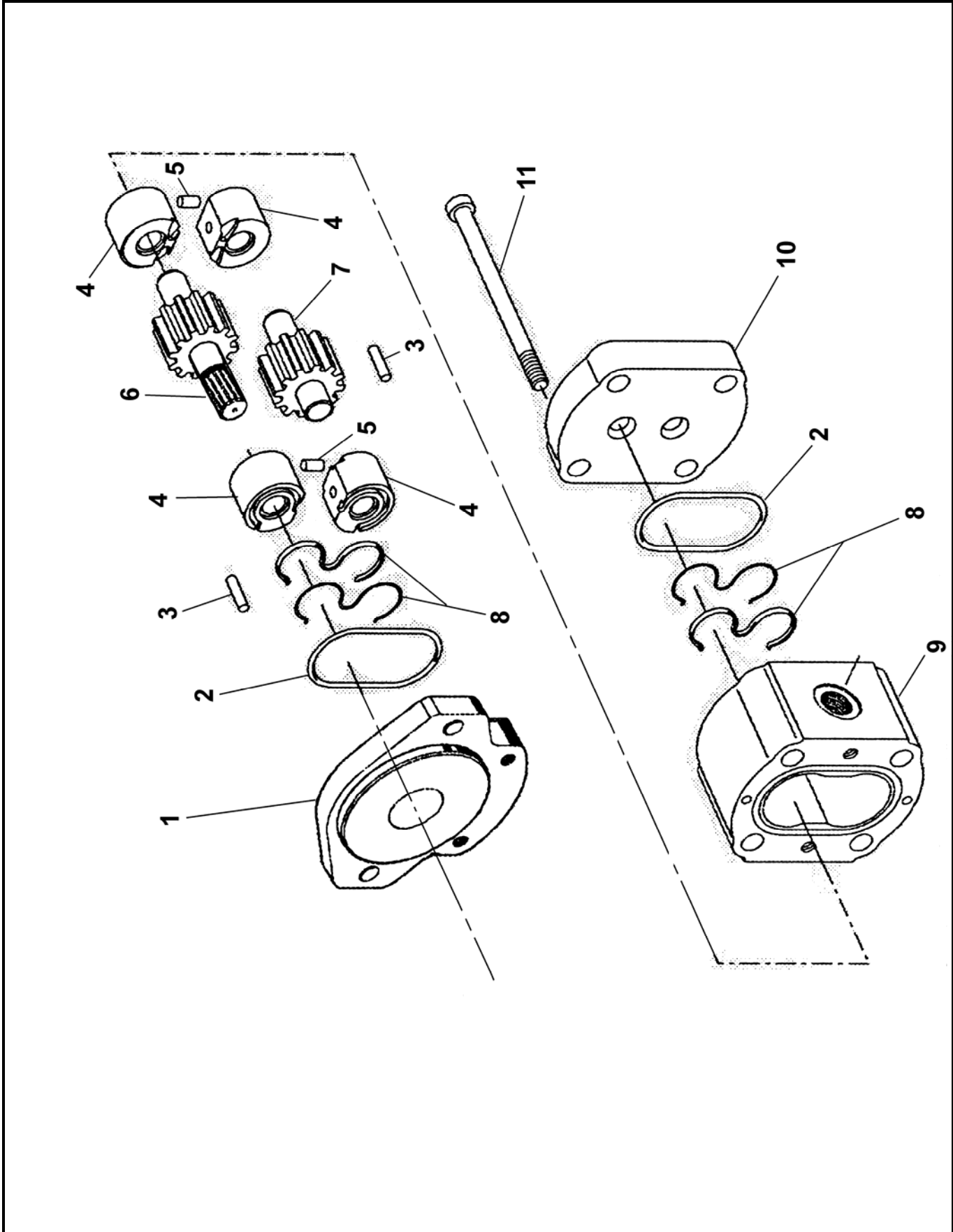

REVISION:



SINGLE AUXILIARY PUMP ASSEMBLY

C50HP
PARTS
GROUP 40
FIGURE 04
PAGE 02

ITEM NO.	REED'S PARTS NO.	DESCRIPTION					QTY
		1	2	3	4	5	
	87013	Assembly, Single Auxiliary Pump (See Group 40, Figure 02 for NHA)					Ref
1		• Cover, Front					1
2		• Seal					2
3		• Pin, Dowel					2
4		• Bearing					4
5		• Pin, Dowel					2
6		• Gear, Driven					1
7		• Gear, Drive					1
8		• Seal					2
9		• Housing, Pump					1
10		• Cover, End					1
11		• Bolt, Hex (attaching parts)					4
-12	87013SK	• Kit, Seal					1
DASH (-) ITEM NOT ILLUSTRATED							

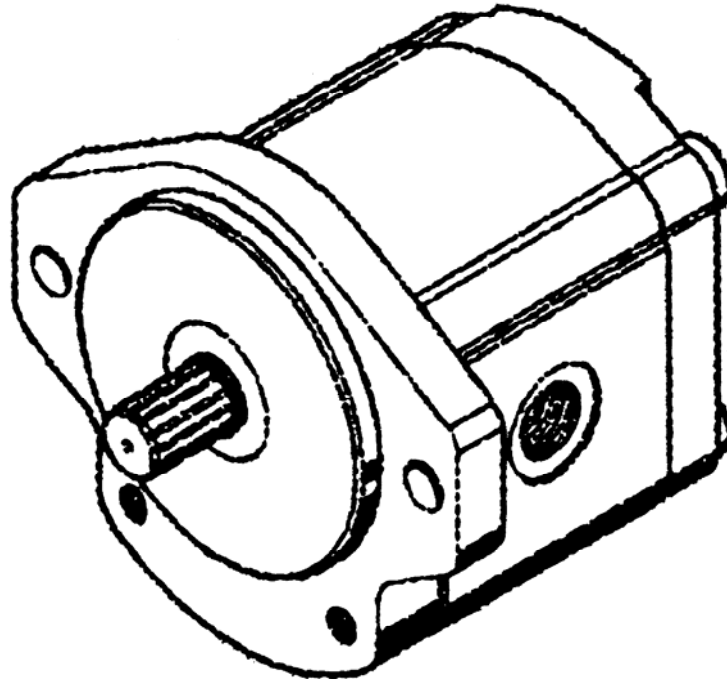

REVISION:



HOT OIL SHUTTLE ASSEMBLY

C50HP
PARTS
GROUP 40
FIGURE 05
PAGE 01

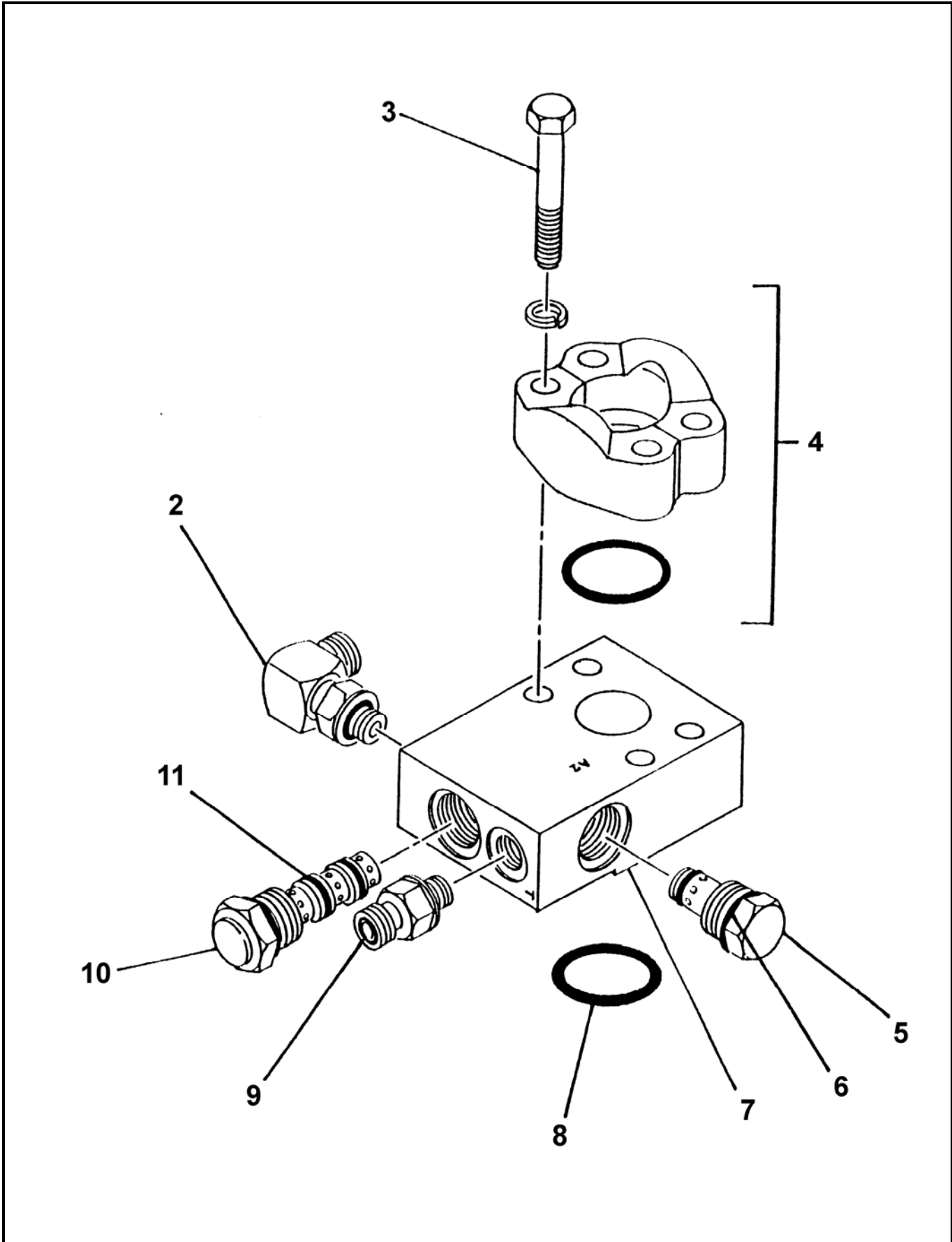

REVISION:



HOT OIL SHUTTLE ASSEMBLY

C50HP
PARTS
GROUP 40
FIGURE 05
PAGE 02

ITEM NO.	REED'S PARTS NO.	DESCRIPTION	QTY
		1 2 3 4 5	
-1	72980	Assembly, Hot Oil Shuttle (See Group 40, Figure 02 for NHA)	Ref
2		• Fitting, 90	1
3		• Bolt, Hex	4
4		• Kit, Flange	1
5	73157-STEEL	• Cartridge, Check Valve	1
6	73251	• • Kit, Check Valve Cartridge Seal For 73157	1
7		• Manifold, Hot Oil Shuttle	1
8		• • O-Ring	1
9		• Filter, STR FS6400-6-6	1
10	73185-STEEL	• Cartridge, Hot Oil Shuttle	1
11	73204	• • Kit, Hot Oil Shuttle Cartridge Seal For 73185	1
		DASH (-) ITEM NOT ILLUSTRATED	

REVISION:



MAIN HYDRAULIC PUMP ASSEMBLY

C50HP
PARTS
GROUP 40
FIGURE 06
PAGE 01

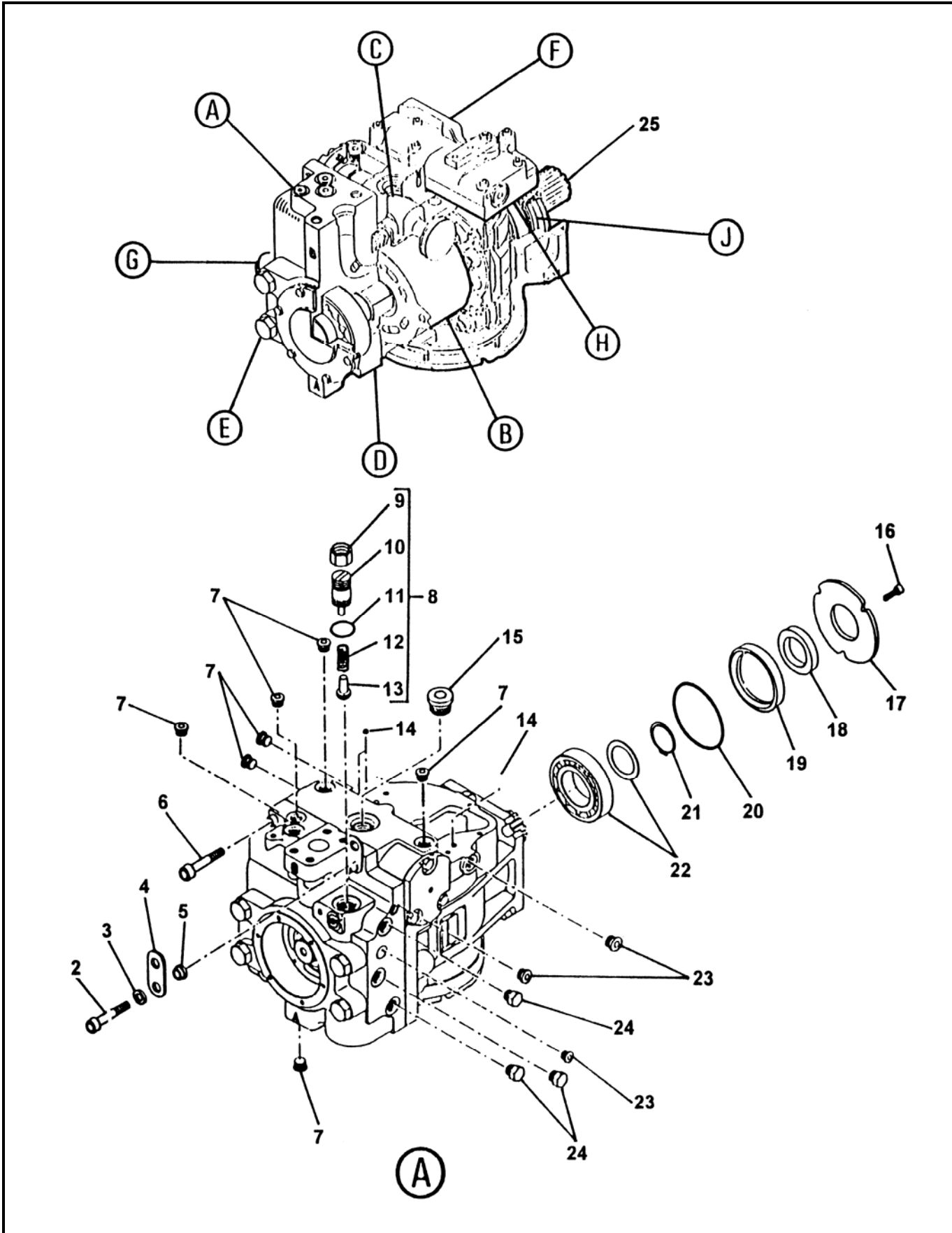

REVISION:



MAIN HYDRAULIC PUMP ASSEMBLY

C50HP
PARTS
GROUP 40
FIGURE 06
PAGE 02

ITEM NO.	REED'S PARTS NO.	DESCRIPTION					QTY
		1	2	3	4	5	
-1	75864	Assembly, Main Hydraulic Pump (See Group 40, Figure 02 for NHA)					Ref
2		• Screw					1
3		• Washer					1
4		• Bracket, Lifting					1
5		• Spacer					1
6		• Screw					1
7		• Plug					7
8		• Kit, Adjustment Charge Relief					1
9		•• Nut					1
10		•• Assembly, Plug					1
11		•• O-Ring					1
12		•• Spring					1
13		•• Puppet					1
14		• Screen, Control Filter					3
15		• Plug					1
16		• Screw					3
17		• Plate, Retainer					1
18		• Seal, Lip					1
19		• Carrier, Seal					1
20		• O-Ring					1
21		• Ring, Retaining					1
22		• Bearing, Roller					1
23		• Plug					3
24		• Plug					3
25		• Shaft, 13T					1

DASH (-) ITEM NOT ILLUSTRATED

REVISION:



MAIN HYDRAULIC PUMP ASSEMBLY

C50HP
PARTS
GROUP 40
FIGURE 06
PAGE 03

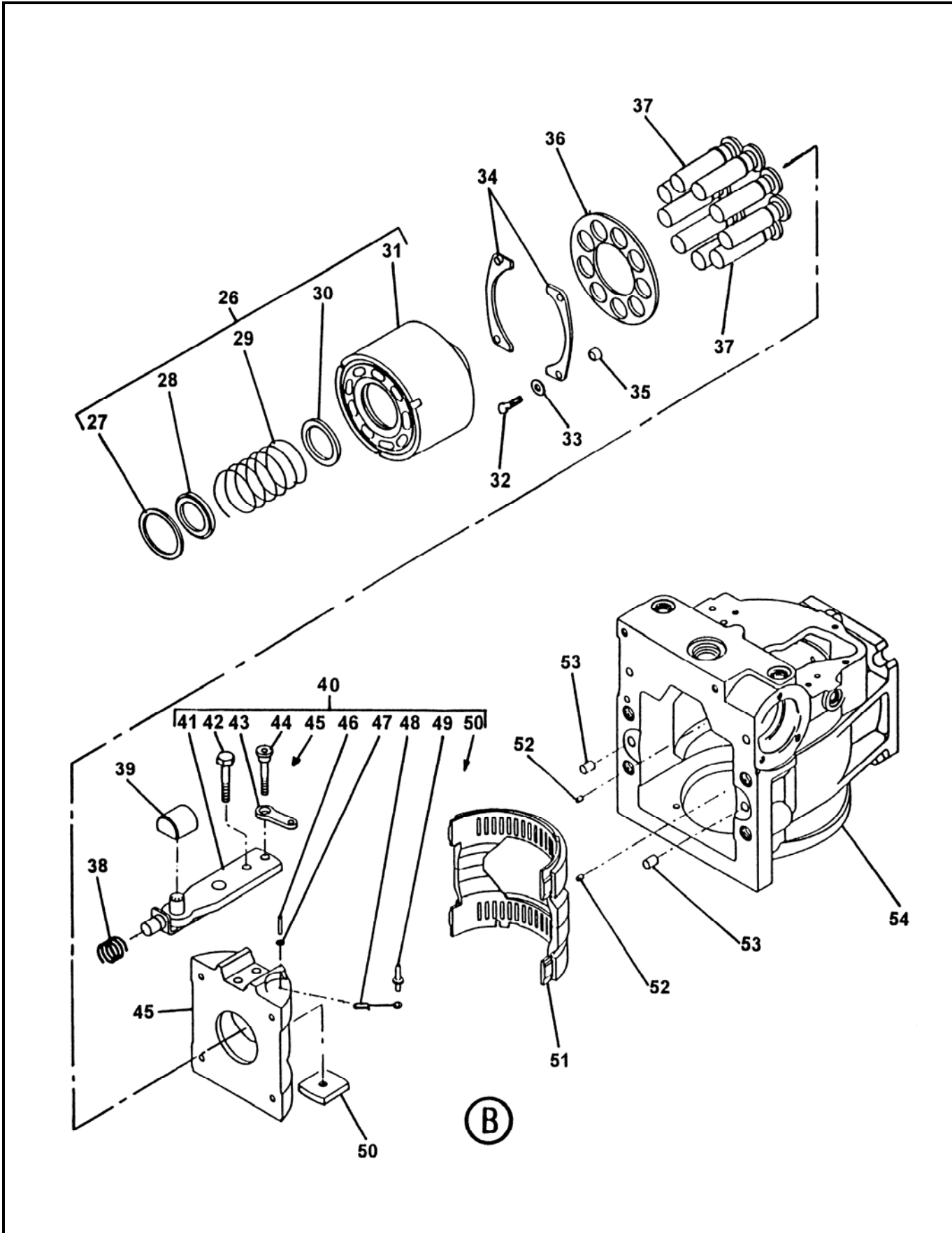

REVISION:



MAIN HYDRAULIC PUMP ASSEMBLY

C50HP
PARTS
GROUP 40
FIGURE 06
PAGE 04

ITEM NO.	REED'S PARTS NO.	DESCRIPTION	QTY
		1 2 3 4 5	
26		• Kit, Cylinder Block	1
27		•• Ring, Retaining	1
28		•• Retainer, Spring	1
29		•• Spring, Cylinder Block	1
30		•• Seat, Spring	1
31		•• Assembly, Cylinder	1
32		• Screw	4
33		• Washer	4
34		• Guide, Slipper Brg	1
35		• Spacer	1
36		• Guide, Slipper	4
37		• Piston, Welded	9
38		• Spring	1
39		• Block, Slider	1
40		• Assembly, Swash plate	1
41		•• Assembly, Servo Arm	1
42		•• Screw	1
43		•• Link, Feedback	1
44		•• Screw	1
45		•• Swash plate	1
46		•• Pin, Sprirl Head	1
47		•• Washer	1
48		•• Link, Cage Locator	1
49		•• Pin	1
50		•• Guide, Swash plate	1
51		• Bearing	1
52		• Pin	2
53		• Pin	2
54		• Housing, Variable	1

REVISION:

MAIN HYDRAULIC PUMP ASSEMBLY

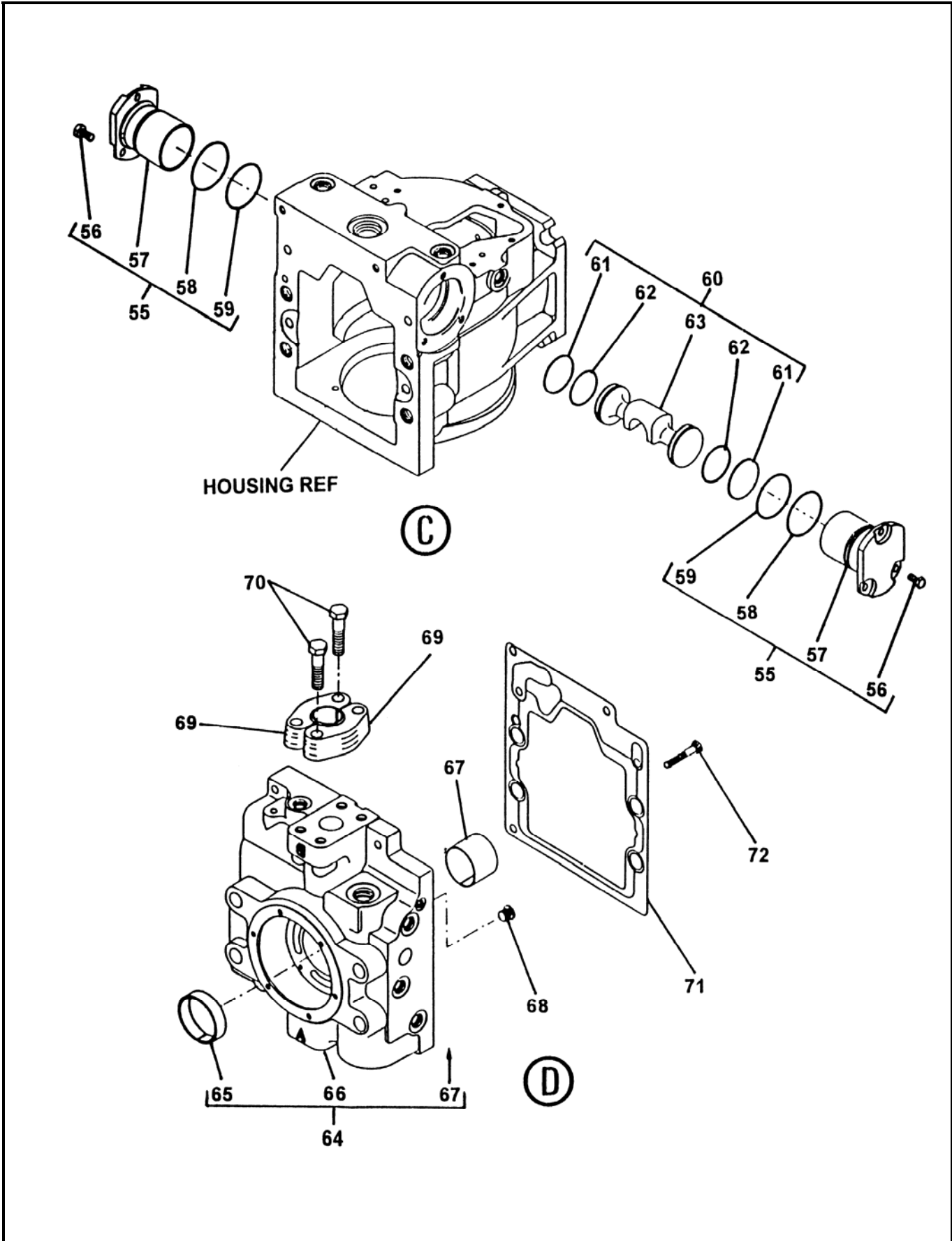



MAIN HYDRAULIC PUMP ASSEMBLY

C50HP
PARTS
GROUP 40
FIGURE 06
PAGE 06

ITEM NO.	REED'S PARTS NO.	DESCRIPTION	QTY
		1 2 3 4 5	
55		• Kit, Servo Sleeve	2
56		•• Screw	3
57		•• Sleeve, Servo	1
58		•• O-Ring	1
59		•• O-Ring	1
60		• Kit, Servo Piston	1
61		•• Ring, Piston	2
62		•• O-Ring	2
63		•• Piston, Servo	1
64		• Kit, Side Port End Cap	1
65		•• Bushing	1
66		•• Cap, End	1
67		•• Bearing, Journal	1
68		• Plug	1
69		• Clamp, Split	4
70		• Screw	4
71		• Gasket, End Cap	1
72		• Screw	1

REVISION:



MAIN HYDRAULIC PUMP ASSEMBLY

C50HP
PARTS
GROUP 40
FIGURE 06
PAGE 07

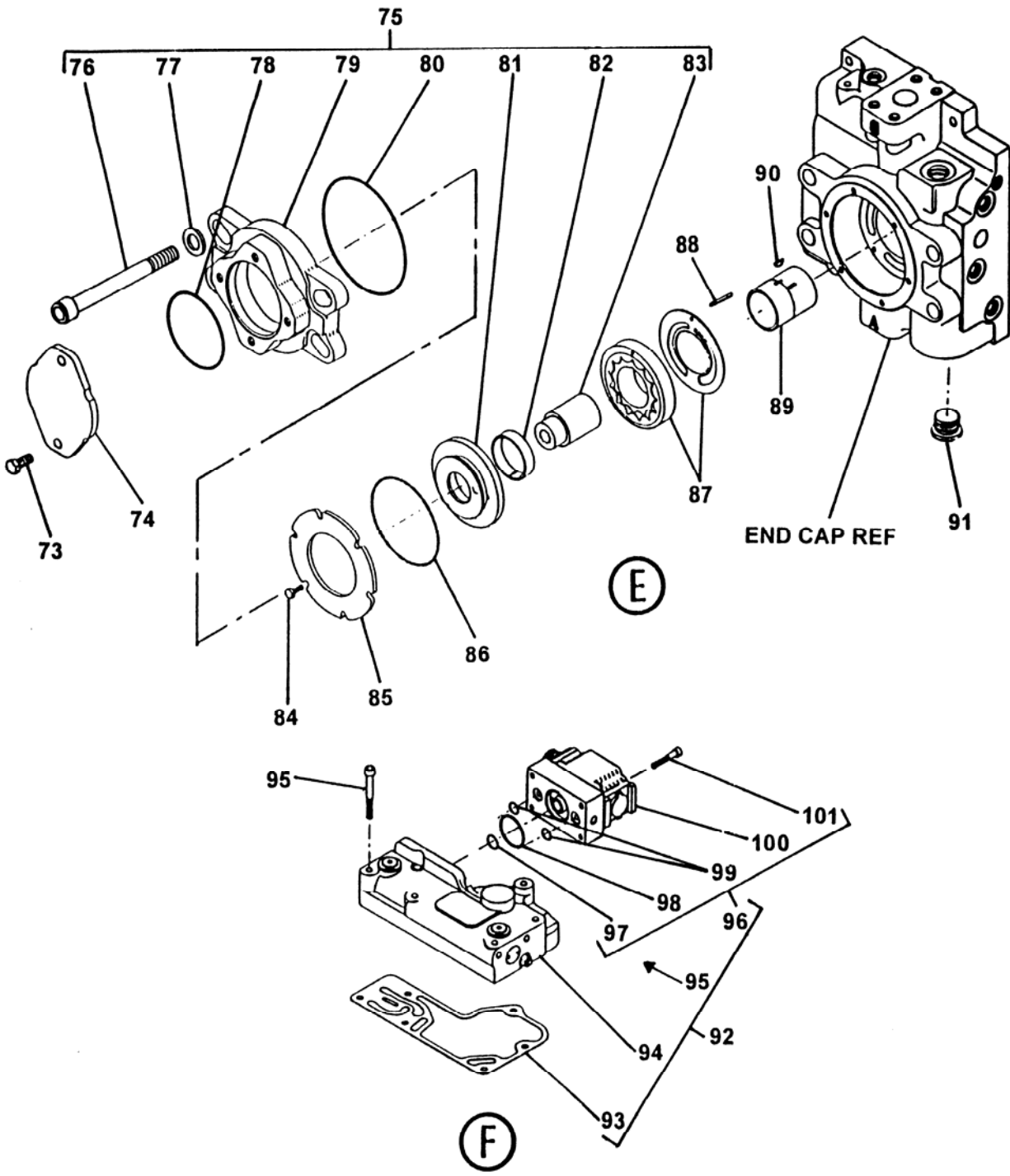

REVISION:



MAIN HYDRAULIC PUMP ASSEMBLY

C50HP
PARTS
GROUP 40
FIGURE 06
PAGE 08

ITEM NO.	REED'S PARTS NO.	DESCRIPTION	QTY
		1 2 3 4 5	
73		• Screw	2
74		• Plate, Cover	1
75		• Kit, Auxiliary Mounting Flange	1
76		•• Screw	4
77		•• Washer	4
78		•• O-Ring	1
79		•• Adapter, Flange	1
80		•• O-Ring	1
81		•• Assembly, Cover	1
82		••• Bushing	1
83		•• Coupling	1
84		• Screw	6
85		• Plate, Retaining	1
86		• O-Ring	1
87		• Pump, Charge	1
88		• Pin	1
89		• Shaft, Charge Pump	1
90		• Key	1
91		• Plug	1
92		• Kit, EDC1 Connector	1
93		•• Gasket, Control	1
94	72867	•• Connector, EDC1 Controller	1
95		•• Screw	6
96		•• Sub - Kit, PCP Type	1
97		••• O-Ring	1
98		••• O-Ring	1
99		••• O-ring	2
100	77040	••• PCP Coil	1
101		••• Screw	4

REVISION:



MAIN HYDRAULIC PUMP ASSEMBLY

C50HP
PARTS
GROUP 40
FIGURE 06
PAGE 09

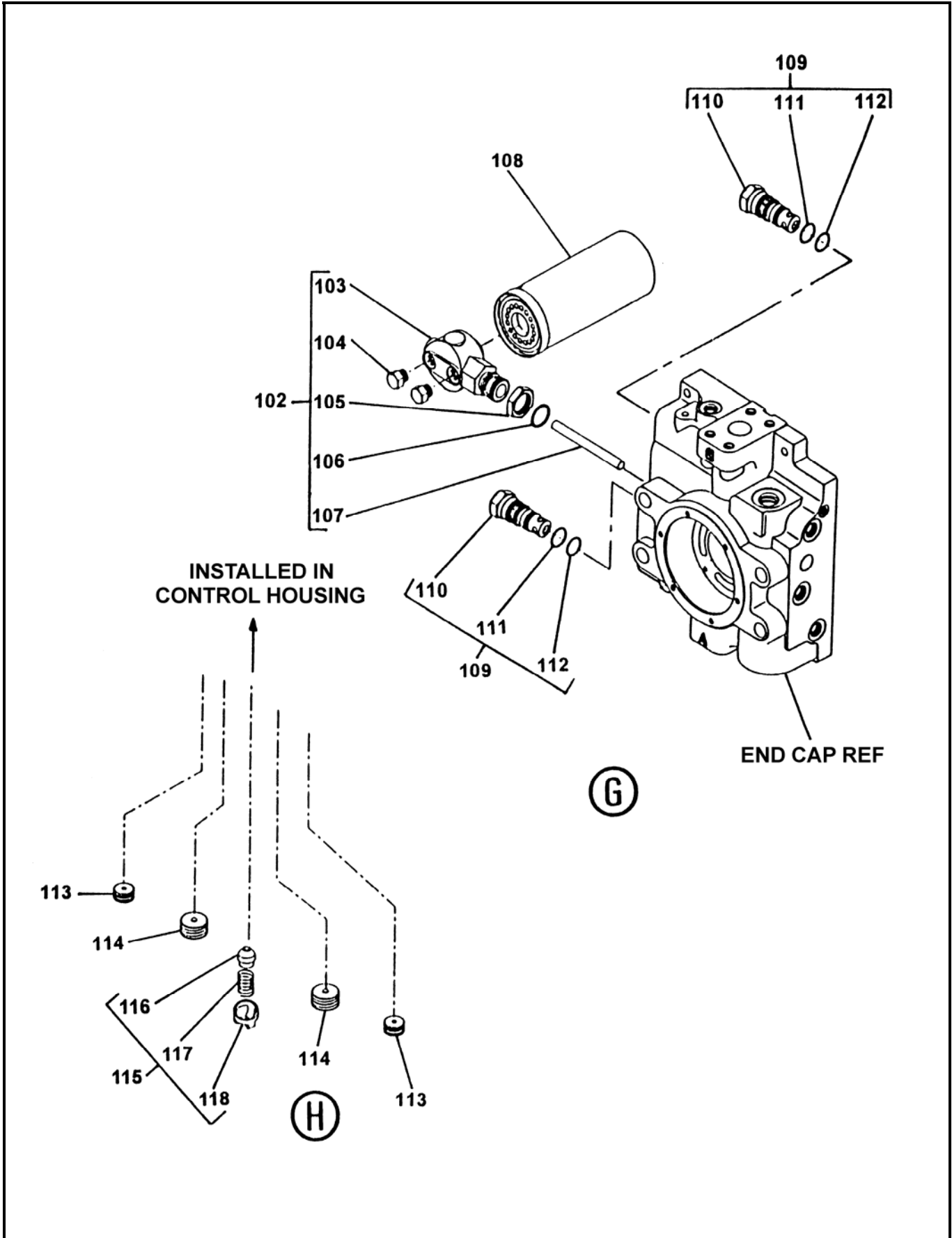

REVISION:



MAIN HYDRAULIC PUMP ASSEMBLY

C50HP
PARTS
GROUP 40
FIGURE 06
PAGE 10

	REED'S PARTS NO.	DESCRIPTION	QTY
		1 2 3 4 5	
102		• Kit, Filtration Manifold	1
103		•• Manifold, Filtration	1
104		•• Plug	2
105		•• Nut	1
106		•• O-Ring	1
107		•• Tube	1
108	73310	• Filter, Hydraulic Oil	1
109	72866	• Kit, Multi - Function Valve	2
110		•• Valve, Multi - Function	1
-110A	77446	•• Kit, Multi - Function Valve Seal	1
111		••• O-Ring	1
112		••• O-Ring	1
113		• Plug, M5 x 6	2
114		• Plug, M8 x 8	2
115		• Kit, Control Orifice	1
116		•• Valve, Orifice Check	1
117		•• Spring	1
118		•• Retainer, Spring	1

REVISION:

MAIN HYDRAULIC PUMP ASSEMBLY

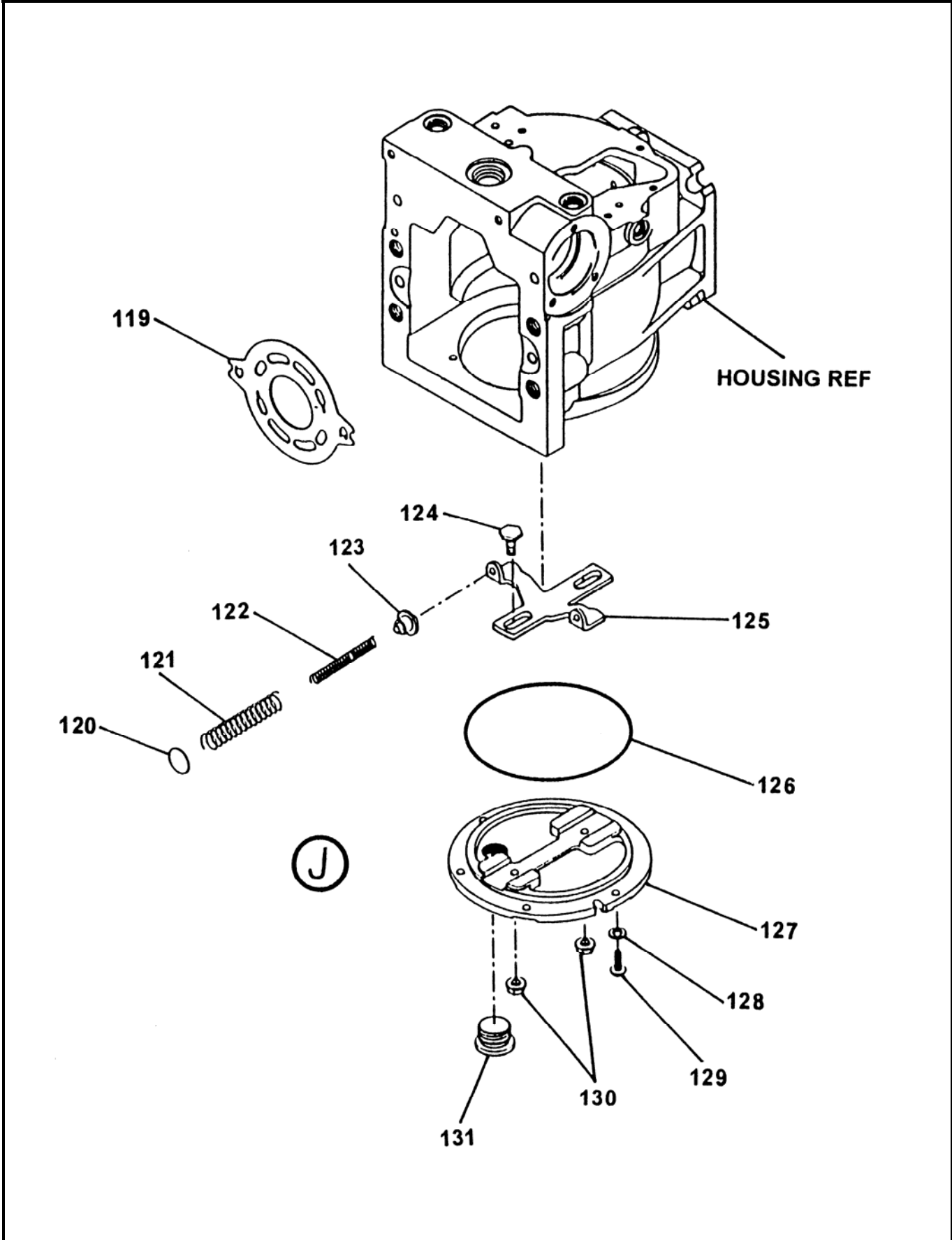

REVISION:



MAIN HYDRAULIC PUMP ASSEMBLY

C50HP
PARTS
GROUP 40
FIGURE 06
PAGE 12

ITEM NO.	REED'S PARTS NO.	DESCRIPTION	QTY
		1 2 3 4 5	
119		• Plate, Pump Valve	1
120		• Shim	2
121		• Spring	2
122		• Spring	2
123		• Seat, Spring	2
124		• Post, Guide	2
125		• Leveler	1
126		• O-Ring	1
127		• Cover, Side	1
128		• Washer	6
129		• Screw	6
130		• Nut	2
131		• Plug	1
-132		• Gasket, Manifold	1
-133		• Kit, 100 PV Overhaul Seal (Item Include 11,17, 19, 32, 58, 59, 61, 62, 71, 78, 80, 86, 93, 97, 98, 99, 106, 111, 112, 126, 129, 130 and 132)	1

DASH (-) ITEM NOT ILLUSTRATED

REVISION:



BATTERY MOUNTING ASSEMBLY

C50HP
PARTS
GROUP 40
FIGURE 07
PAGE 01

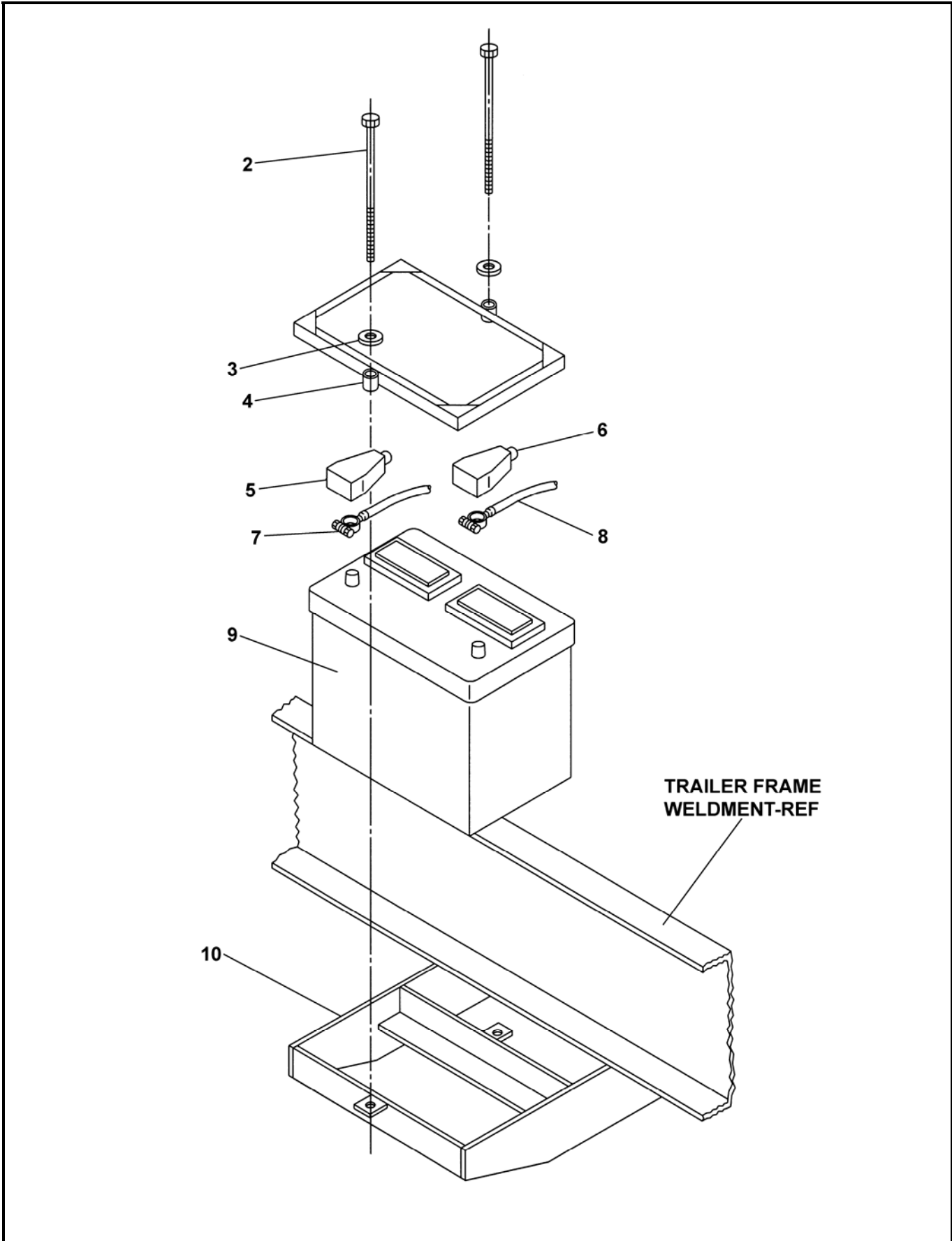

REVISION:



BATTERY MOUNTING ASSEMBLY

C50HP
PARTS
GROUP 40
FIGURE 07
PAGE 02

ITEM NO.	REED'S PARTS NO.	DESCRIPTION	QTY
		1 2 3 4 5	
-1	40-07	Assembly, Battery Mounting (See Group 40, Figure 01 for NHA)	Ref
2		• Bolt, Hex	2
3		• Washer Flat	2
4	72945	• Holder, Battery Down	1
5	77720	• Insulator, Negative Battery (Black)	1
6	77719	• Insulator, Positive Battery (Red)	1
7	72116	• Cable, 26 Inch Negative Battery (Black)	1
8	72014	• Cable, 38 Inch Long Positive Battery (Red)	1
9	77075	• Battery, 12 VDC	1
10	86240	• Weldment, Battery Box	1
-11	85348	• Connector, SPNO 12VDC	1
		DASH (-) ITEM NOT ILLUSTRATED	

REVISION:



TRAILER MOUNTED PUMP 02 MODEL C50HP
GROUP 40 POWER TRAIN INSTALLATION

C50HP
PARTS
GROUP 40
FIGURE 08
PAGE 01

THIS PAGE INTENTIONALLY LEFT BLANK.

REED TRAILER MOUNTED CONCRETE PUMP 02 MODEL C50HP ILLUSTRATED PARTS MANUAL GROUP 50 CONTROLS INSTALLATION CONTAINS THE FOLLOWING FIGURES:

- FIGURE 00** TABLE OF CONTENTS
- FIGURE 01** CONTROLS INSTALLATION
- FIGURE 02** CONTROL BOX INSTALLATION
- FIGURE 03** 50 FEET CABLE REMOTE CONTROL ASSEMBLY
- FIGURE 04** 100 FEET CABLE REMOTE CONTROL ASSEMBLY
- FIGURE 05** RADIO REMOTE CONTROL ASSEMBLY

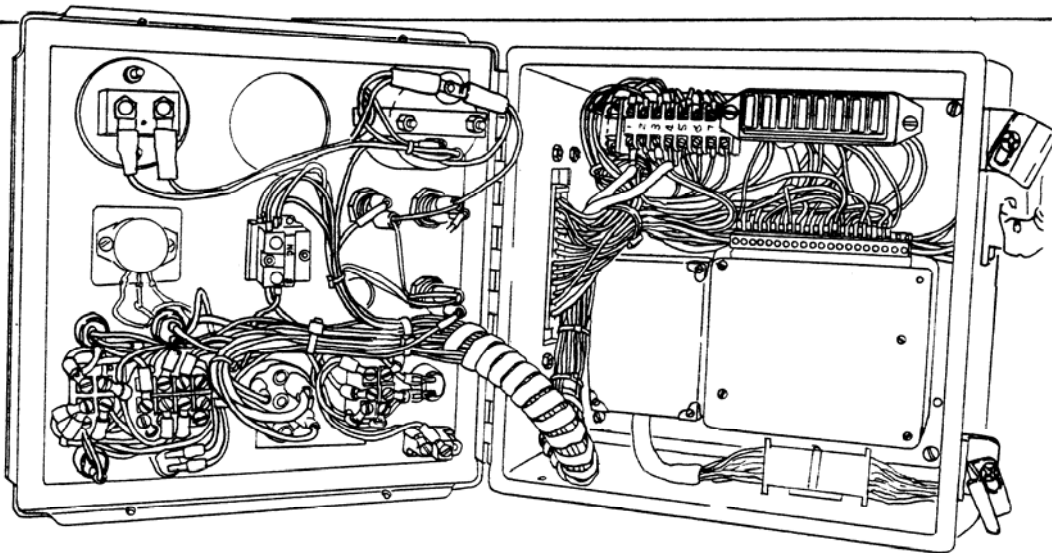
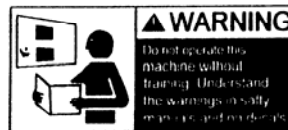



CONTROL INSTALLATION

C50HP
PARTS
GROUP 50
FIGURE 01
PAGE 01

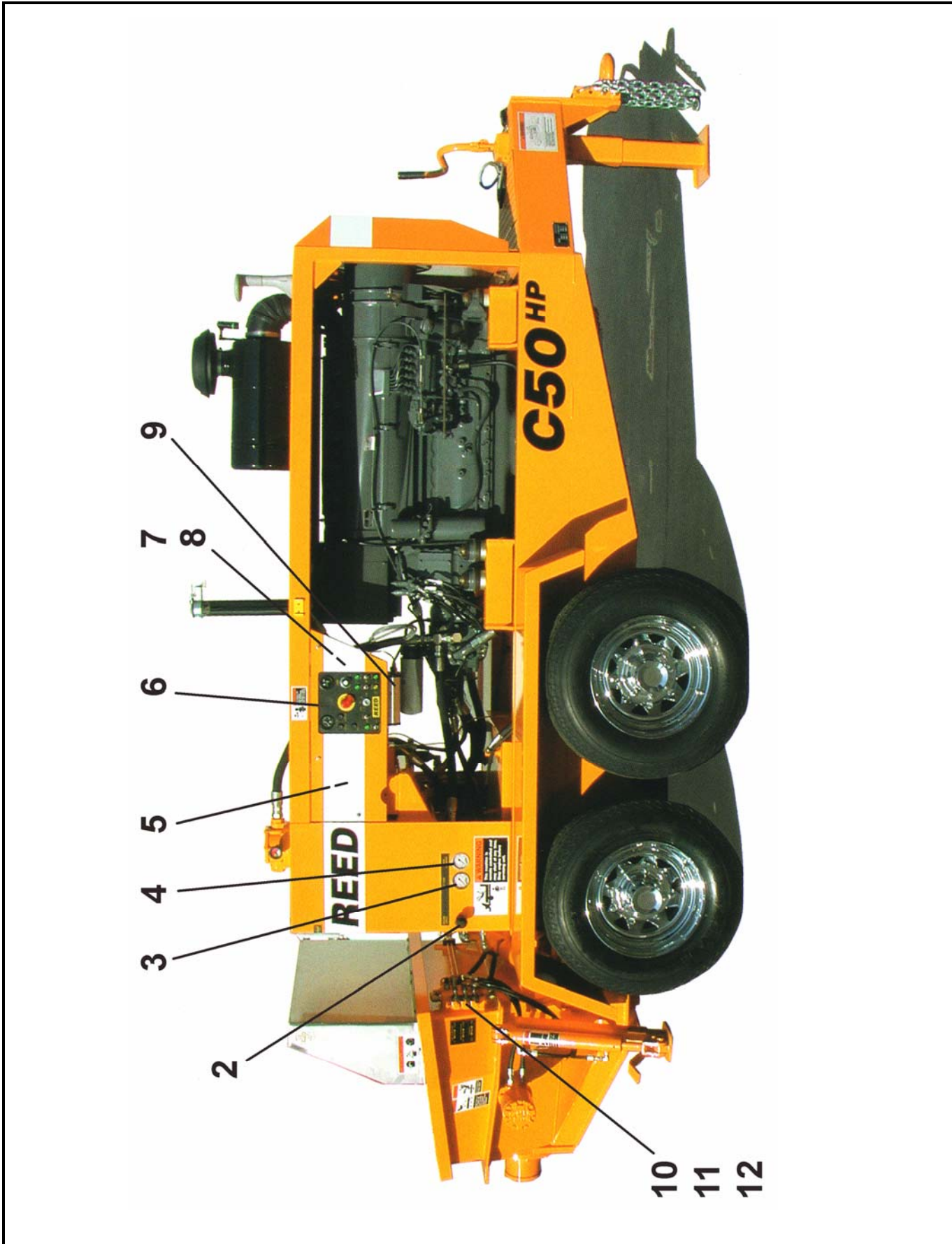

REVISION:



CONTROL INSTALLATION

C50HP
PARTS
GROUP 50
FIGURE 01
PAGE 02

ITEM NO.	REED'S PARTS NO.	DESCRIPTION					QTY
		1	2	3	4	5	
-1	50-01	Installation, Control (See Group 10, Figure 01 for NHA)					Ref
2	73313	• Cable, Throttle Control (See Group 40, Figure 01 for REF)					1
3	70366	• Gauge, 3,000 PSI Hydraulic (See Group 30, Figure 02 for REF)					1
4	74562	• Gauge, 6,000 PSI Hydraulic (See Group 30, Figure 02 for REF)					1
5	800347	• Horn, 12 V					1
6	85397	• Assembly, Control Box (See Group 50, Figure 02 for DET)					1
7	85398	• Assembly, 50 Feet Cable Remote Control (See Group 50, Figure 03 for DET)					1
8	85398A	• Assembly, 100 Feet Cable Remote Control (See Group 50, Figure 04 for DET)					1
9	86480	• Assembly, Radio Remote Control (Optional Item) (See Group 50, Figure 05 for DET)					1
-9A	85818	• • Radio Remote-Only					1
10	20-07	• Assembly, Agitator/Outriggers Control Valve (Optional Item) (See Group 20, Figure 07 for REF)					1
11	80-15	• Assembly, 1 Spool Valve (Optional Item) (See Group 80, Figure 15 for REF)					1
12	80-17	• Assembly, 2 Spool Valve (Optional Item) (See Group 80, Figure 17 for REF)					1
-13	86532	• Assembly, Trailer Wiring Harness (See Schematic Section for REF)					1
-14	85399	• Assembly, Engine Wiring Harness (See Schematic Section for REF)					1
DASH (-) ITEM NOT ILLUSTRATED							

REVISION:



CONTROL BOX ASSEMBLY

C50HP
PARTS
GROUP 50
FIGURE 02
PAGE 01

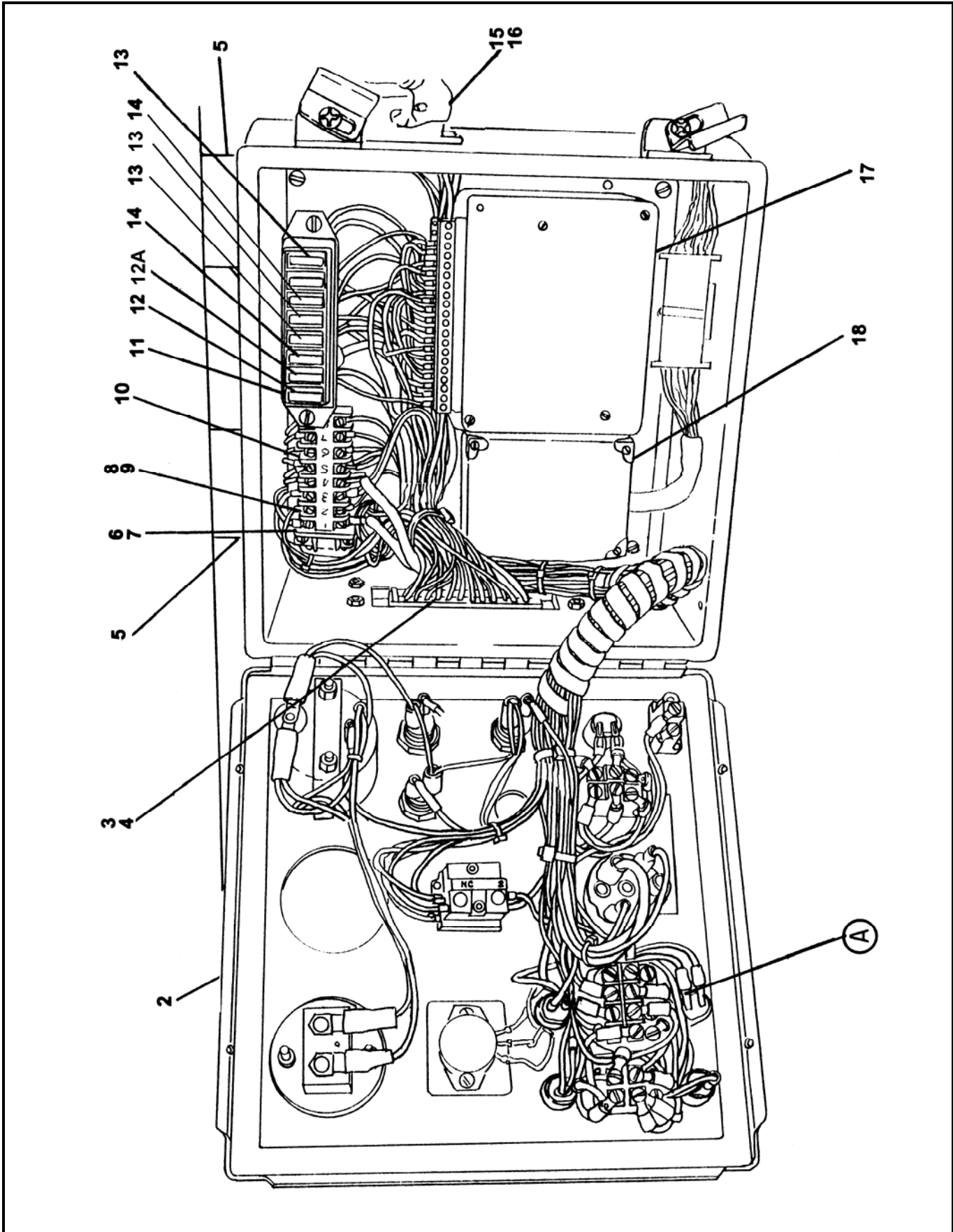

REVISION:



CONTROL BOX ASSEMBLY

C50HP
PARTS
GROUP 50
FIGURE 02
PAGE 02

ITEM NO.	REED'S PARTS NO.	DESCRIPTION	QTY
		1 2 3 4 5	
-1	85397	Assembly, Control Box (See Group 50, Figure 01 for NHA)	Ref
2	85400	• Box, Control	1
3	78696	• Insert, Connector	1
4	78697	• Base, Connector	1
5	73748	• Bumper	4
6	75654	• End, Barrier	1
7	72821	• Rail, 0.333 Feet Barrier	1
8	72820	• Terminal	8
9	72824	• Jumper	2
10	85354	• Block, Fuse	1
11	85419	• Stand Off	1
12	800447	• Fuse, 25	1
12A	800448	• Fuse, 20	1
13	800449	• Fuse, 10	3
14	90392	• Fuse, 5	2
15	79963	• Insert, Connector	1
16	79965	• Base, Connector	1
17	85596	• Box, Black	1
18	85334	• Box, Pump Black	1
-19	10528	• Nut	1
-20	10523	• Relief, Strain	1
		DASH (-) ITEM NOT ILLUSTRATED	

REVISION:



CONTROL BOX ASSEMBLY

C50HP
PARTS
GROUP 50
FIGURE 02
PAGE 03

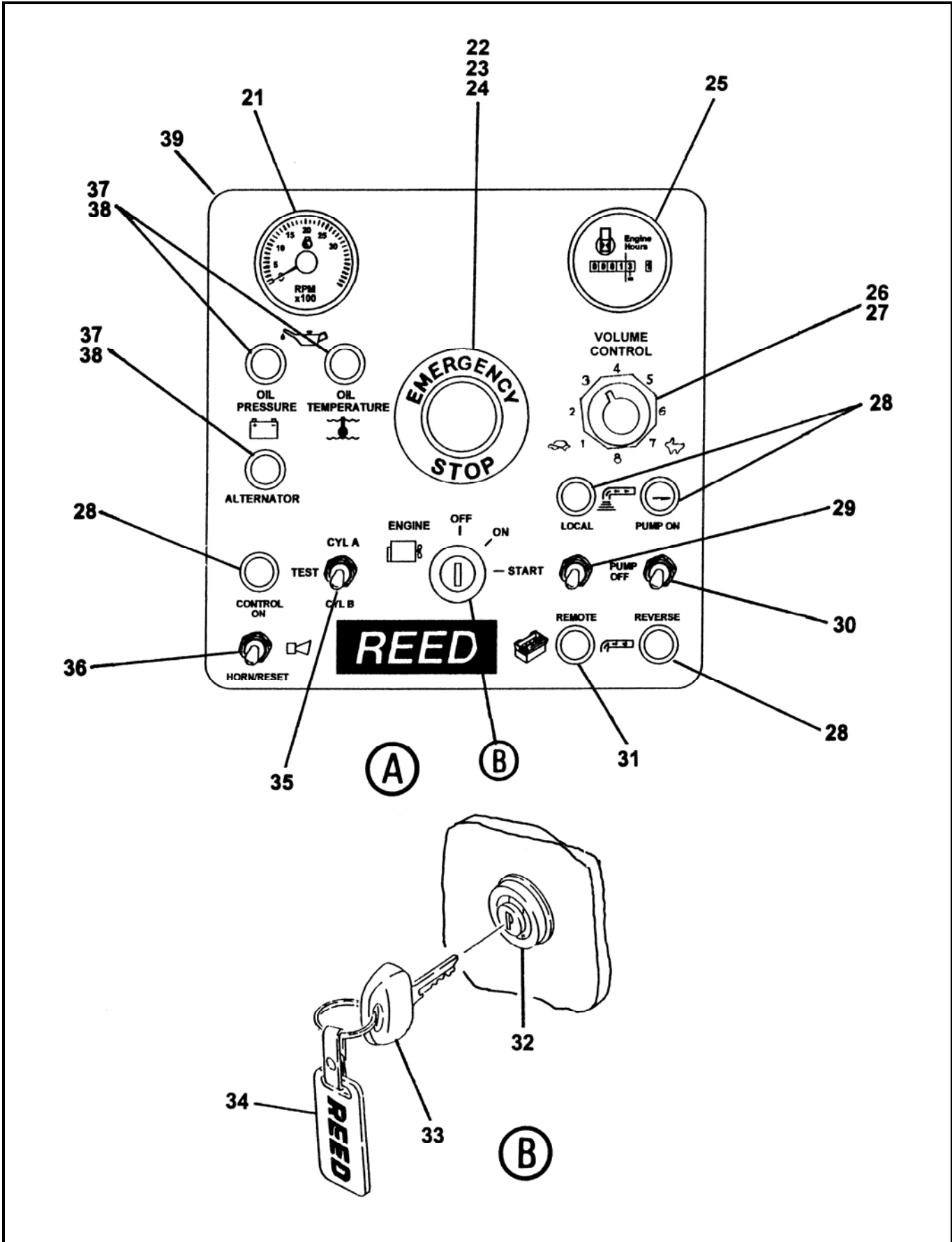

REVISION:



CONTROL BOX ASSEMBLY

C50HP
PARTS
GROUP 50
FIGURE 02
PAGE 04

ITEM NO.	REED'S PARTS NO.	DESCRIPTION	QTY
		1 2 3 4 5	
21	78687	• Tachometer	1
22	85342	• Operator, Emergency Stop	1
23	85343	• Block, Contact	1
24	85344	• Bulb, Emergency Stop	1
25	74240	• Meter, Engine Hour	1
26	77642	• Potentiometer, 100 OHM	1
27	72777	• Resistor, Green 100 OHM	1
28	85355	• Pilot, Light	4
29	78563	• Switch, Local / Remote	1
30	72003	• Switch, Pump On / Reverse	1
31	85356	• Pilot, Light	1
32	71154	• Switch, Ignition	1
33	71155	• • Key	1
34	72862	• Gauge, Proximity Switch	1
35	85346	• Switch, CYL A / CYL B	1
36	85347	• Switch, Horn / Reset	1
37	73775	• Indicator, Red Light 14 VDC	3
38	72022	• Bulb, Indicator	3
39	85409	• Decal, C50HP Control Box	1
		DASH (-) ITEM NOT ILLUSTRATED	

REVISION:



50 FEET CABLE REMOTE CONTROL ASSEMBLY

C50HP
PARTS
GROUP 50
FIGURE 03
PAGE 01

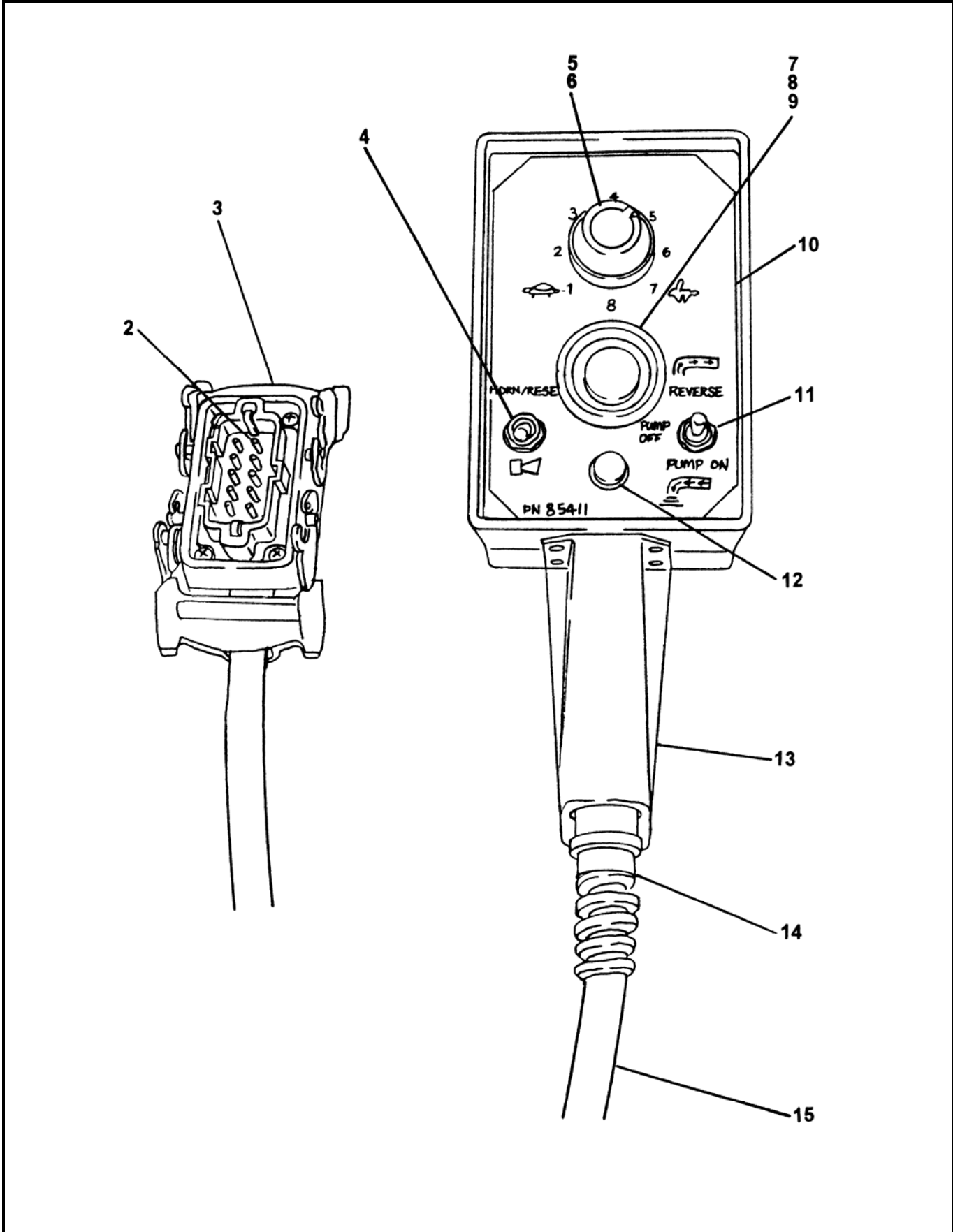

REVISION:



50 FEET CABLE REMOTE CONTROL ASSEMBLY

C50HP
PARTS
GROUP 50
FIGURE 03
PAGE 02

ITEM NO.	REED'S PARTS NO.	DESCRIPTION	QTY
		1 2 3 4 5	
-1	85398	Assembly, 50 Feet Cable Remote Control (See Group 50, Figure 01 for NHA)	Ref
2	79964	• Connector, Insert	1
3	79966	• Connector, Hood	1
4	85347	• Switch, Horn / Reset	1
5	77642	• Potentiometer, 100 OHM	1
6	72777	• Resistor, Green 100 OHM	1
7	85342	• Operator, Emergency Stop	1
8	85343	• Block, Contact	1
9	85344	• Bulb, Emergency Stop	1
10	85411	• Decal, C50HP Remote Control Box	1
11	72003	• Switch, Pump On / Reverse	1
12	85355	• Pilot, Light	1
13	85412	• Enclosure, Remote Control	1
14	85621	• Relief, Spiral Strain	1
15	85620	• Cable, 50 Feet Remote Control	1
		DASH (-) ITEM NOT ILLUSTRATED	

REVISION:



100 FEET CABLE REMOTE CONTROL ASSEMBLY

C50HP
PARTS
GROUP 50
FIGURE 04
PAGE 01

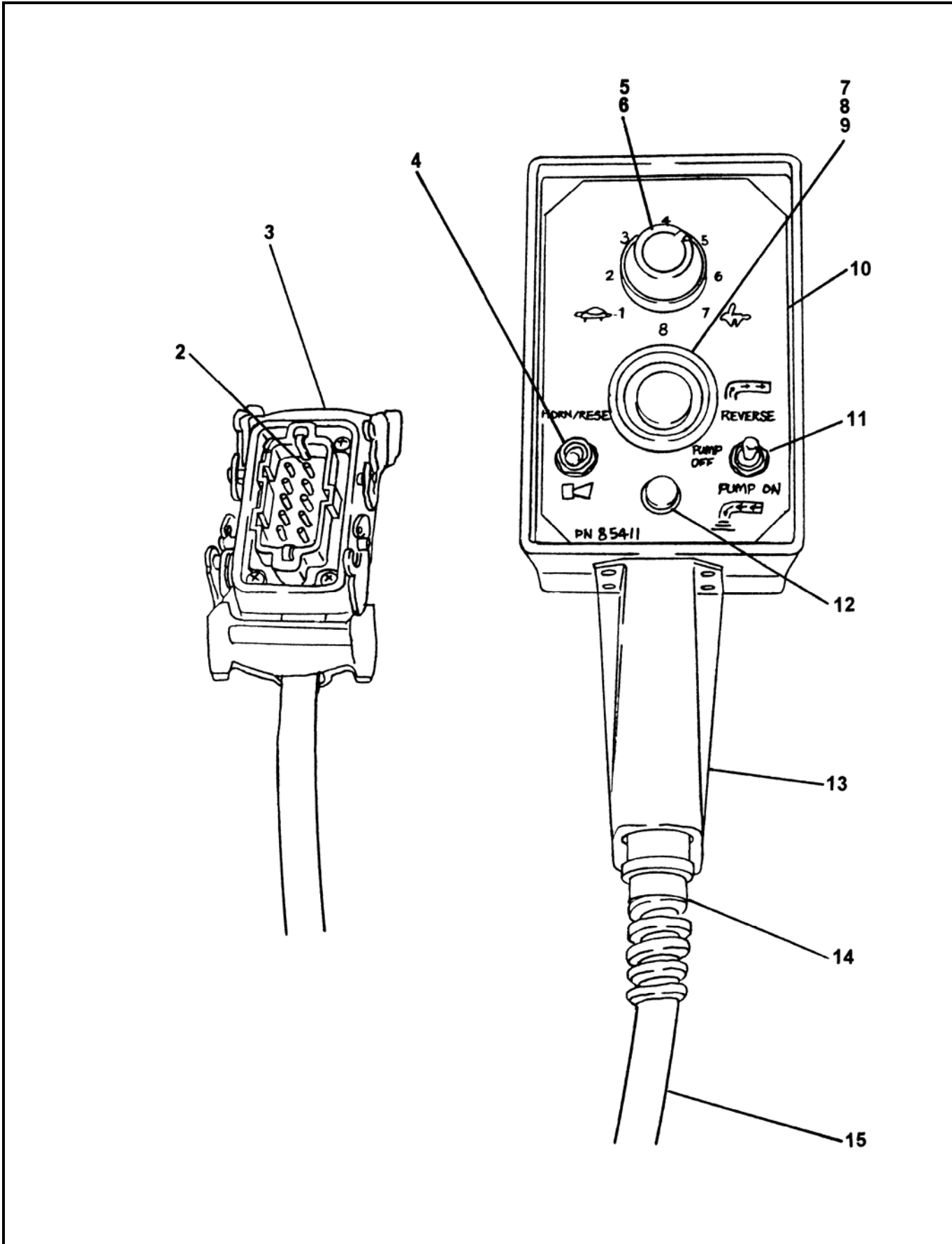

REVISION:



100 FEET CABLE
REMOTE CONTROL ASSEMBLY

C50HP
PARTS
GROUP 50
FIGURE 04
PAGE 02

ITEM NO.	REED'S PARTS NO.	DESCRIPTION	QTY
		1 2 3 4 5	
-1	85398A	Assembly, 100 Feet Cable Remote Control (See Group 50, Figure 01 for NHA)	Ref
2	79964	• Connector, Insert	1
3	79966	• Connector, Hood	1
4	85347	• Switch, Horn / Reset	1
5	77642	• Potentiometer, 100 OHM	1
6	72777	• Resistor, Green 100 OHM	1
7	85342	• Operator, Emergency Stop	1
8	85343	• Block, Contact	1
9	85344	• Bulb, Emergency Stop	1
10	85411	• Decal, C50HP Remote Control Box	1
11	72003	• Switch, Pump On / Reverse	1
12	85355	• Pilot, Light	1
13	85412	• Enclosure, Remote Control	1
14	85621	• Relief, Spiral Strain	1
15	85816	• Cable, 100 Feet Remote Control	1
		DASH (-) ITEM NOT ILLUSTRATED	

REVISION:



**OPTIONAL RADIO REMOTE
CONTROL ASSEMBLY**

**C50HP
PARTS
GROUP 50
FIGURE 05
PAGE 01**

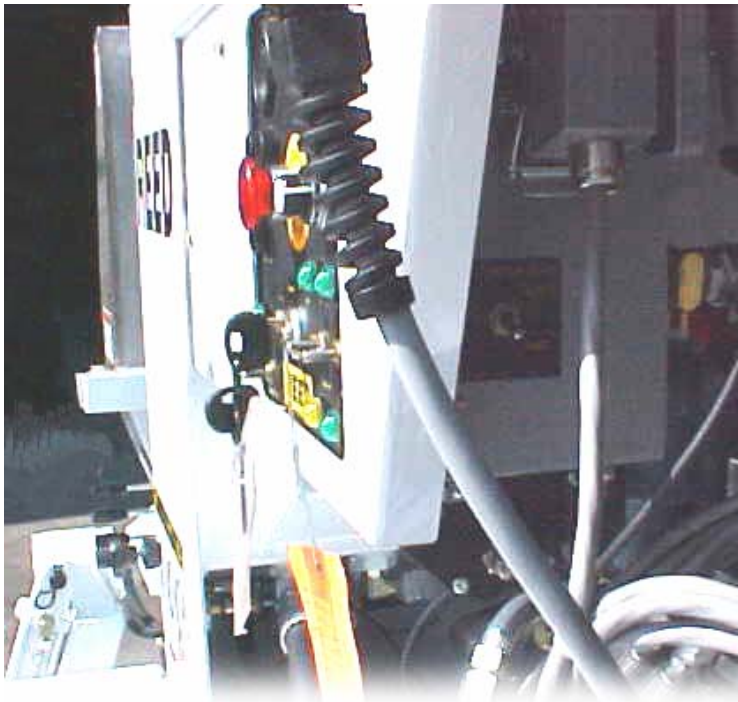

VIEW A

OPTIONAL RADIO REMOTE CONTROL ASSEMBLY

ITEM NO.	REED'S PARTS NO.	DESCRIPTION	QTY
		1 2 3 4 5	
1	86480	Assembly, Radio Remote (See Group 50, Figure 01 for NHA)	Ref
2	85818	• Remote, Radio-Remtron Pump Boss	1
3	72777	• Resistor-Green 100 Ohm	1
-4	79966	• Connector, Hood-Latch 10P	1
-5	79964	• Connector, Insert 10P Male16A	1
-6	-	• Antenna, Remote Control (Part of 85818 Kit)	1
7	-	• Transmitter w/Holster (Part of 85818 Kit)	1
8	-	• Receiver (Part of 85818 Kit)	1
9	-	• Cable, Coaxial (Part of 85818 Kit)	1
-	-	DASH (-) ITEM NOT ILLUSTRATED	
		Refer to SCHEMATICS SECTION FOR WIRING DIAGRAMS	



PN 85818 REMOTE KIT



**TRAILER MOUNTED PUMP 02 MODEL C50HP
GROUP 50 CONTROLS INSTALLATION**

**C50HP
PARTS
GROUP 50
FIGURE 06
PAGE 01**

THIS PAGE INTENTIONALLY LEFT BLANK.

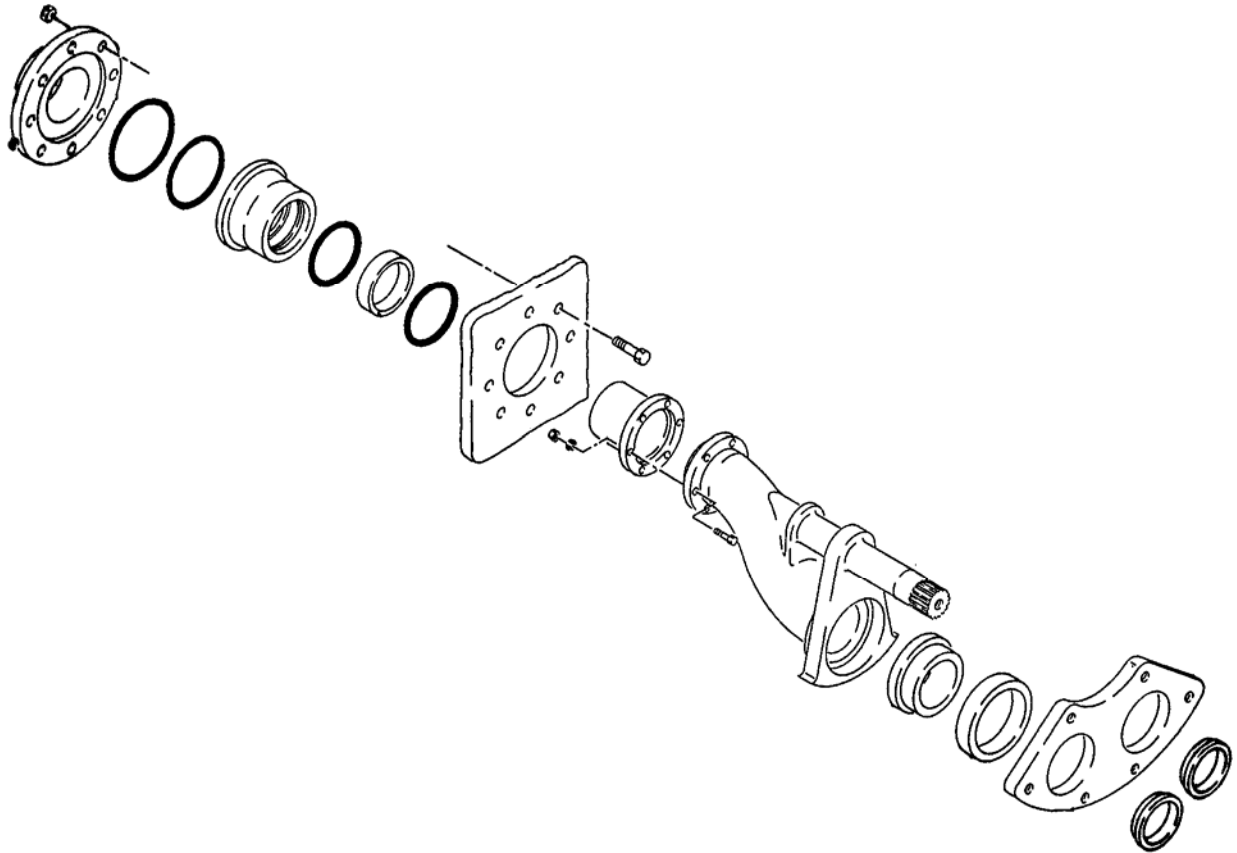

**REED TRAILER MOUNTED CONCRETE PUMP 02 MODEL C50HP
ILLUSTRATED PARTS MANUAL GROUP 60 PUMPING TRAIN INSTALLATION
CONTAINS THE FOLLOWING FIGURES:**

- | | |
|------------------|---------------------------------------|
| FIGURE 00 | TABLE OF CONTENTS |
| FIGURE 01 | PUMPING TRAIN INSTALLATION |
| FIGURE 02 | SWING VALVE ASSEMBLY |
| FIGURE 03 | SWING RAM CYLINDER SUB-ASSEMBLY |
| FIGURE 04 | MATERIAL CYLINDER ASSEMBLY |
| FIGURE 05 | FLUSHBOX ASSEMBLY |
| FIGURE 06 | HYDRAULIC DRIVE CYLINDER ASSEMBLY |
| FIGURE 07 | HYDRAULIC DRIVE CYLINDER SUB-ASSEMBLY |



DUAL SHIFT PUMPING TRAIN INSTALLATION

C50HP
PARTS
GROUP 60
FIGURE 01
PAGE 01

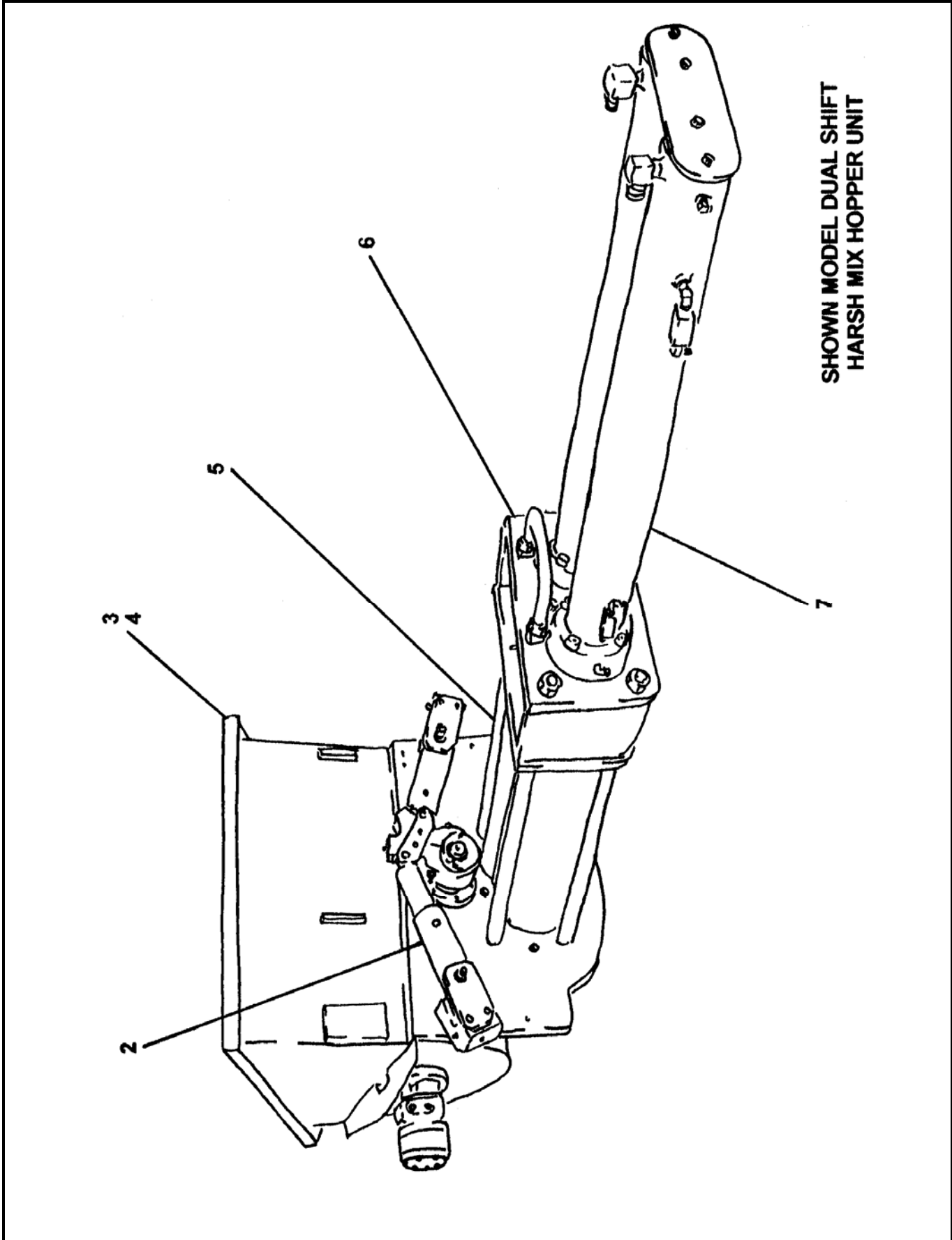

SHOWN MODEL DUAL SHIFT
HARSH MIX HOPPER UNIT

REVISION:



**DUAL SHIFT
PUMPING TRAIN INSTALLATION**

**C50HP
PARTS
GROUP 60
FIGURE 01
PAGE 02**

ITEM NO.	REED'S PARTS NO.	DESCRIPTION	QTY
		1 2 3 4 5	
-1	60-01	Installation, Dual Shift Pumping Train (See Group 10, Figure 01 and Figure 04 for NHA)	Ref
2	60-03	• Assembly, Dual Shift Swing Valve (See Group 60, Figure 03 for DET)	1
3	20-01	• Installation, Standard Hopper (See Group 20, Figure 01 for REF)	Ref
4	20-02	• Installation, Harsh Mix Hopper (See Group 20, Figure 02 for REF)	Ref
5	86311	• Assembly, Material Cylinder (See Group 60, Figure 07 for DET)	1
6	60-08	• Assembly, Flushbox (See Group 60, Figure 08 for DET)	1
7	86306	• Assembly, Hydraulic Drive Cylinder (See Group 60, Figure 09 for DET)	1

DASH (-) ITEM NOT ILLUSTRATED



SWING VALVE ASSEMBLY

C50HP
PARTS
GROUP 60
FIGURE 02
PAGE 01

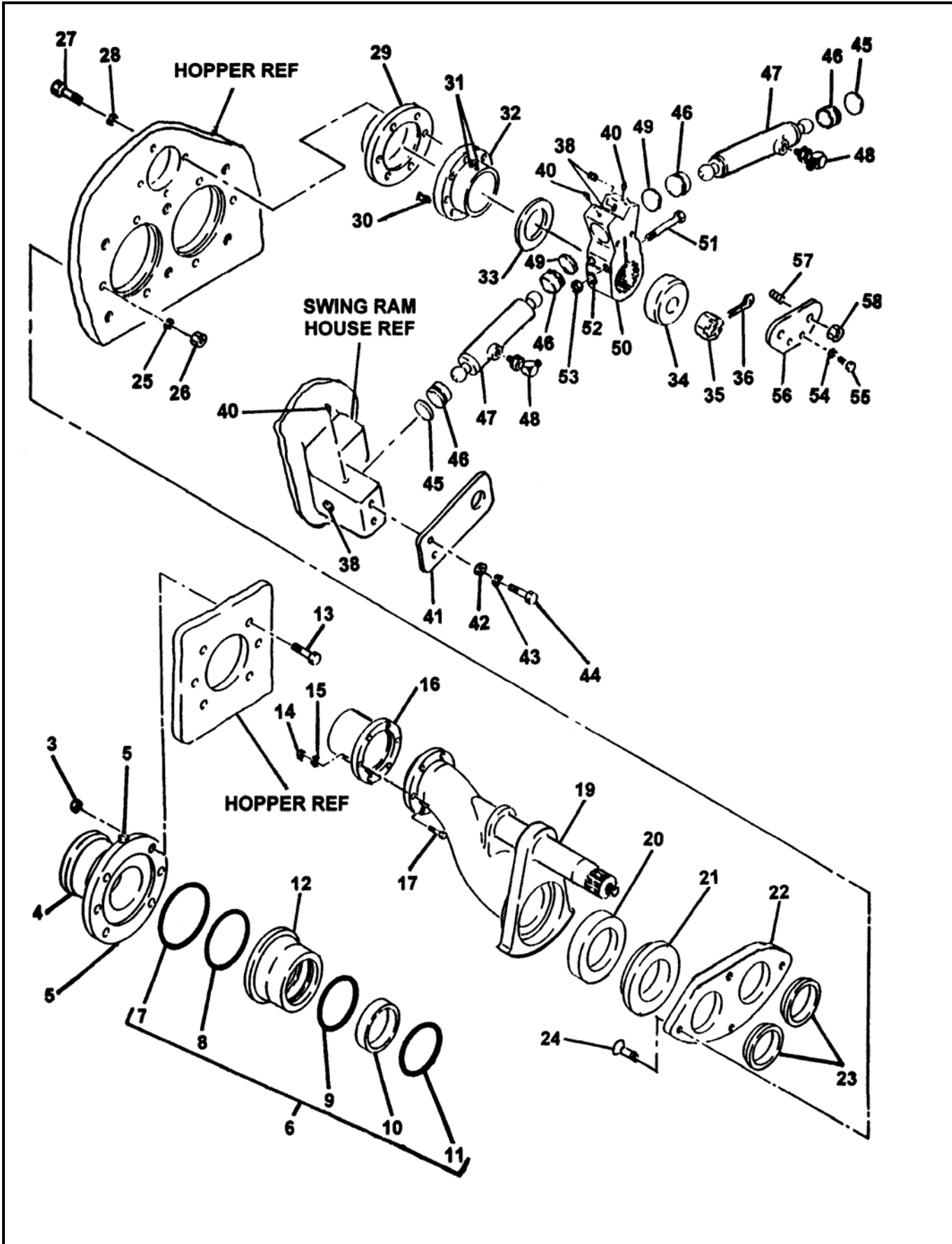

REVISION:



SWING VALVE ASSEMBLY

C50HP
PARTS
 GROUP 60
 FIGURE 02
 PAGE 02

ITEM NO.	REED'S PARTS NO.	DESCRIPTION	QTY
		1 2 3 4 5	
-1	60-02	Assembly, Dual Shift Swing Valve (See Group 60, Figure 01 for NHA)	Ref
-2	86321	• Assembly, Outlet Group	1
3		•• Nut	6
4	72482	•• Outlet, Machine 5"	1
5		•• Fitting, Grease	2
6	79895	•• Kit, Outlet Seal	1
7	77761	••• O-Ring, Large	1
8	77762	••• O-Ring, Small	1
9	86504	••• Seal, Modified Outlet Thick	1
10	77763	••• Band, Guide	1
11	77765	••• Seal, Outlet Thick	1
12	72309	•• Housing, Outlet Seal	1
13		•• Bolt, Hex	6
14		•• Nut, Nylock (attaching parts)	6
15		•• Washer, Lock (attaching parts)	6
16	70042	•• Outlet, Chromed	1
17		•• Bolt, Hex (attaching parts)	6
-18	86317	• Assembly, Swing Tube Group	1
19	86984	•• Weldment, Swing Tube	1
20	86085	•• Seal, 6 Inch Single Lip	1
21	72310	•• Ring, 6 Inch Single Lip Wear	1
22	86031	•• Plate, Wear	1
23	86086	•• Ring, Anti Chip	2
24	74988	•• Bolt, Universal Kit	1
25		•• Washer, Lock	4
26		•• Nut, Hex	4
27		•• Bolt, Hex	4
28		•• Washer, Lock	4
29	85962	•• Seal, Flange Bearing	1
30		•• Pin, Dowel	1
31		•• Fitting, Grease 90	2
32	85133	•• Bearing, 3 Inch Spline Flange	1
33	85294	•• Washer, Thrust	1
34	86985	•• Spacer, Swing Tube Nut	1
35	87012	•• Nut, Swing Tube	1
36		•• Pin, Cotter	1
-37	86320	• Assembly, Swing Tube Dual Shift Group	1
38		•• Plug, Pipe	4
39	86052	•• Pin, Spring	4
40		•• Fitting, Grease 90	2
41	86441	•• Retainer, Swing Ram	2
DASH (-) ITEM NOT ILLUSTRATED			

REVISION:



SWING VALVE ASSEMBLY

C50HP
PARTS
GROUP 60
FIGURE 02
PAGE 03

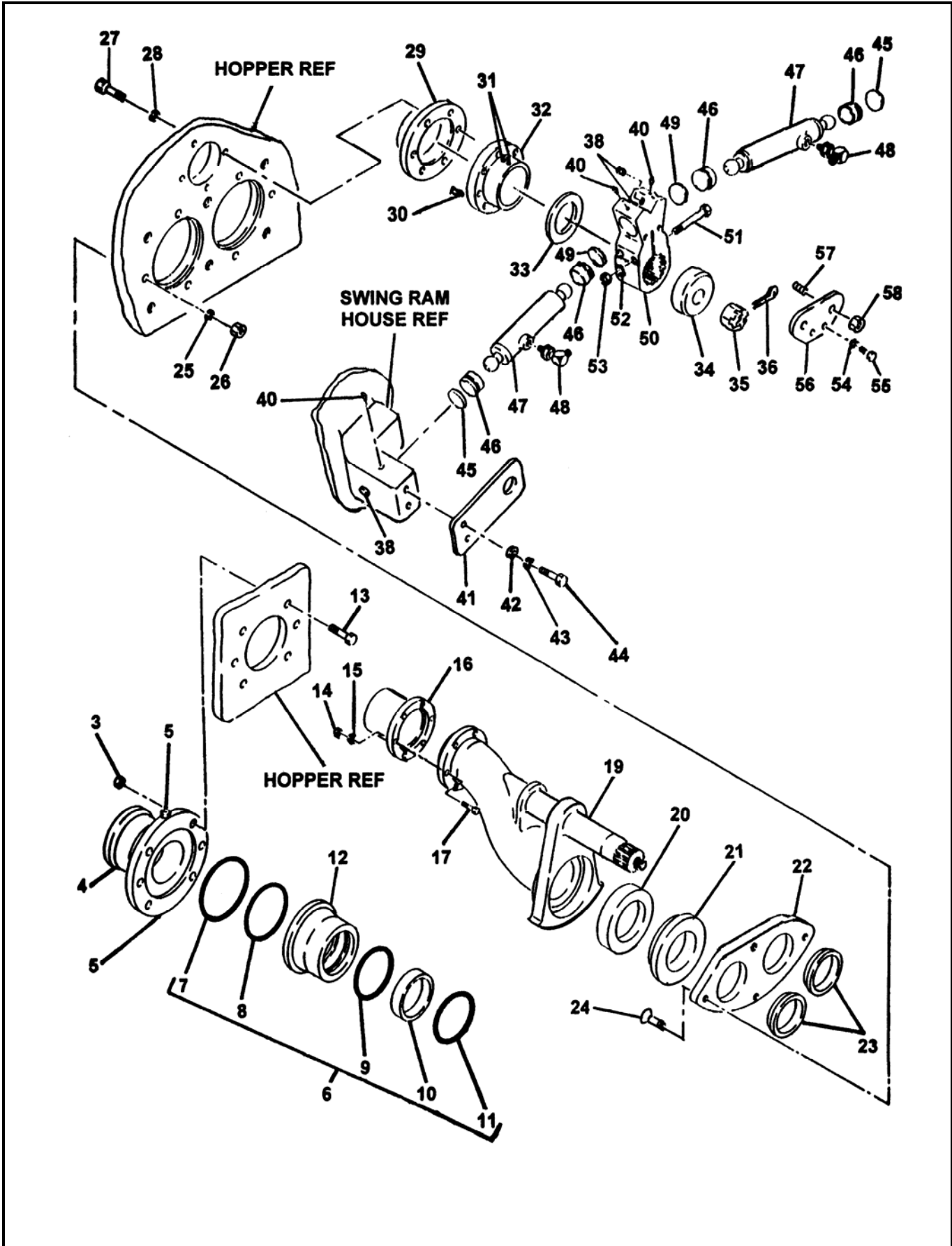

REVISION:



SWING VALVE ASSEMBLY

C50HP
PARTS
 GROUP 60
 FIGURE 02
 PAGE 04

ITEM NO.	REED'S PARTS NO.	DESCRIPTION					QTY
		1	2	3	4	5	
42		••	Washer, Flat (attaching parts)				4
43		••	Washer, Lock (attaching parts)				4
44		••	Bolt, Hex (attaching parts)				4
45	75501	••	Spacer				2
46	76798	••	Socket, Ball				4
47	86220	••	Assembly, Dual Shift Swing Ram Cylinder (See Group 60, Figure 03 for DET)				1
48	75502	••	Fitting, 90				2
49	75501	••	Spacer				2
50	85956	••	Crank, 3 Inch Dual Shift Splined Bell				1
51		••	Bolt, Hex (attaching parts)				2
52		••	Washer, SPL Lock (attaching parts)				2
53		••	Nut, Hex (attaching parts)				2
54		••	Washer, Lock				2
55	86283	••	Screw, Set				2
56	86282	••	Retainer, Dual Shift Cylinder				1
57		••	Stud				2
58		••	Nut, Hex				2

DASH (-) ITEM NOT ILLUSTRATED

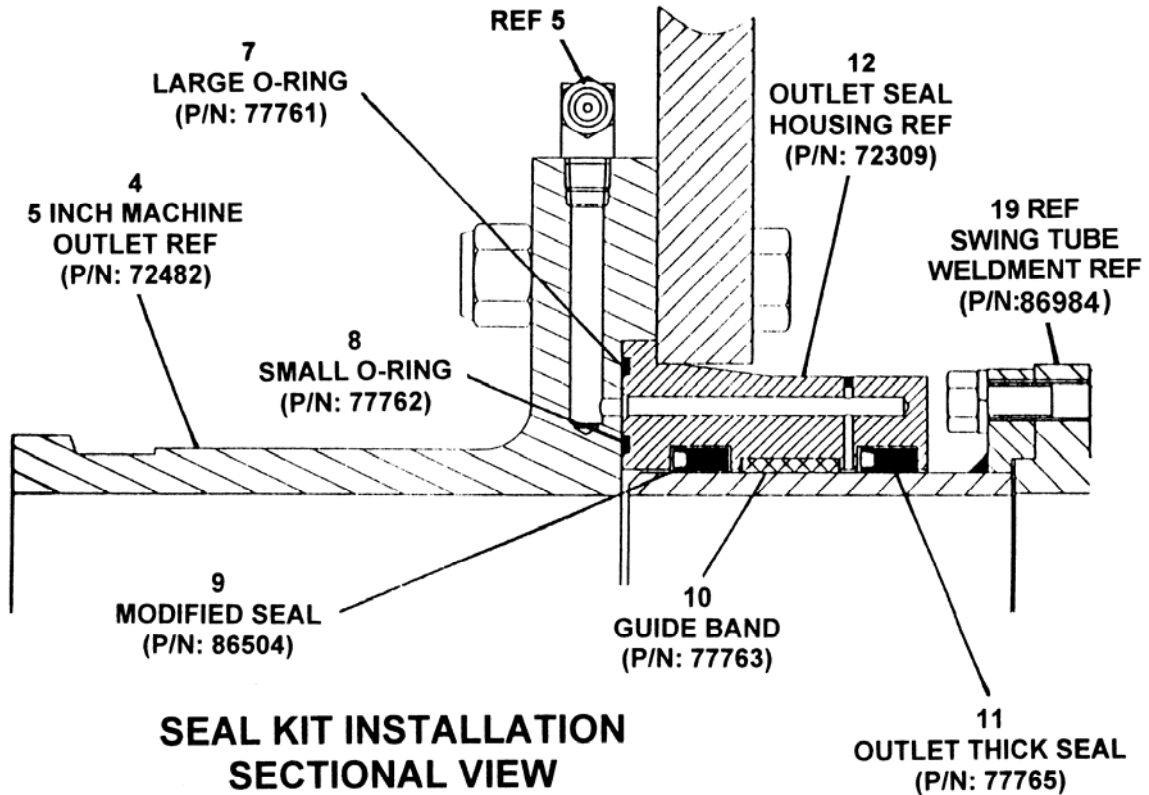

REVISION:



DUAL SHIFT SWING RAM CYLINDER ASSEMBLY

C50HP
PARTS
GROUP 60
FIGURE 03
PAGE 01

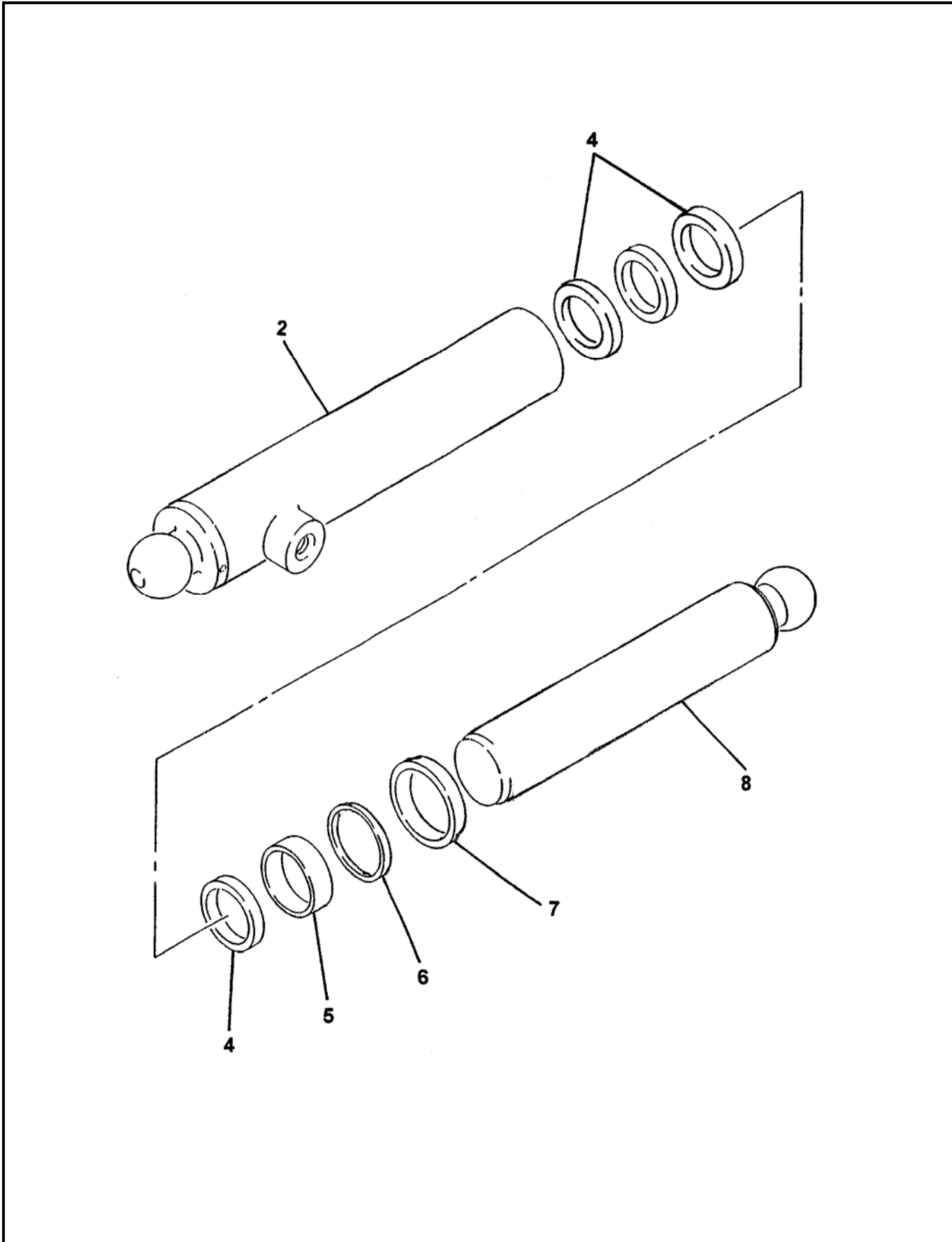

REVISION:



**DUAL SHIFT
SWING RAM CYLINDER ASSEMBLY**

**C50HP
PARTS
GROUP 60
FIGURE 03
PAGE 02**

ITEM NO.	REED'S PARTS NO.	DESCRIPTION	QTY
		1 2 3 4 5	
-1	86220	Assembly, Swing Ram Cylinder (See Group 60, Figure 02 for NHA)	Ref
2		• Weldment, Cylinder Case	1
-3	86220-SKTX	• Kit, Seal	1
4		•• Ring, Wear	1
5		•• U-Cup	1
6		•• Ring, Back-Up	4
7		•• Wiper, Rod	1
8		•• Weldment, Cylinder Rod	1
		DASH (-) ITEM NOT ILLUSTRATED	

REVISION:



MATERIAL CYLINDER ASSEMBLY

C50HP
PARTS
GROUP 60
FIGURE 04
PAGE 01

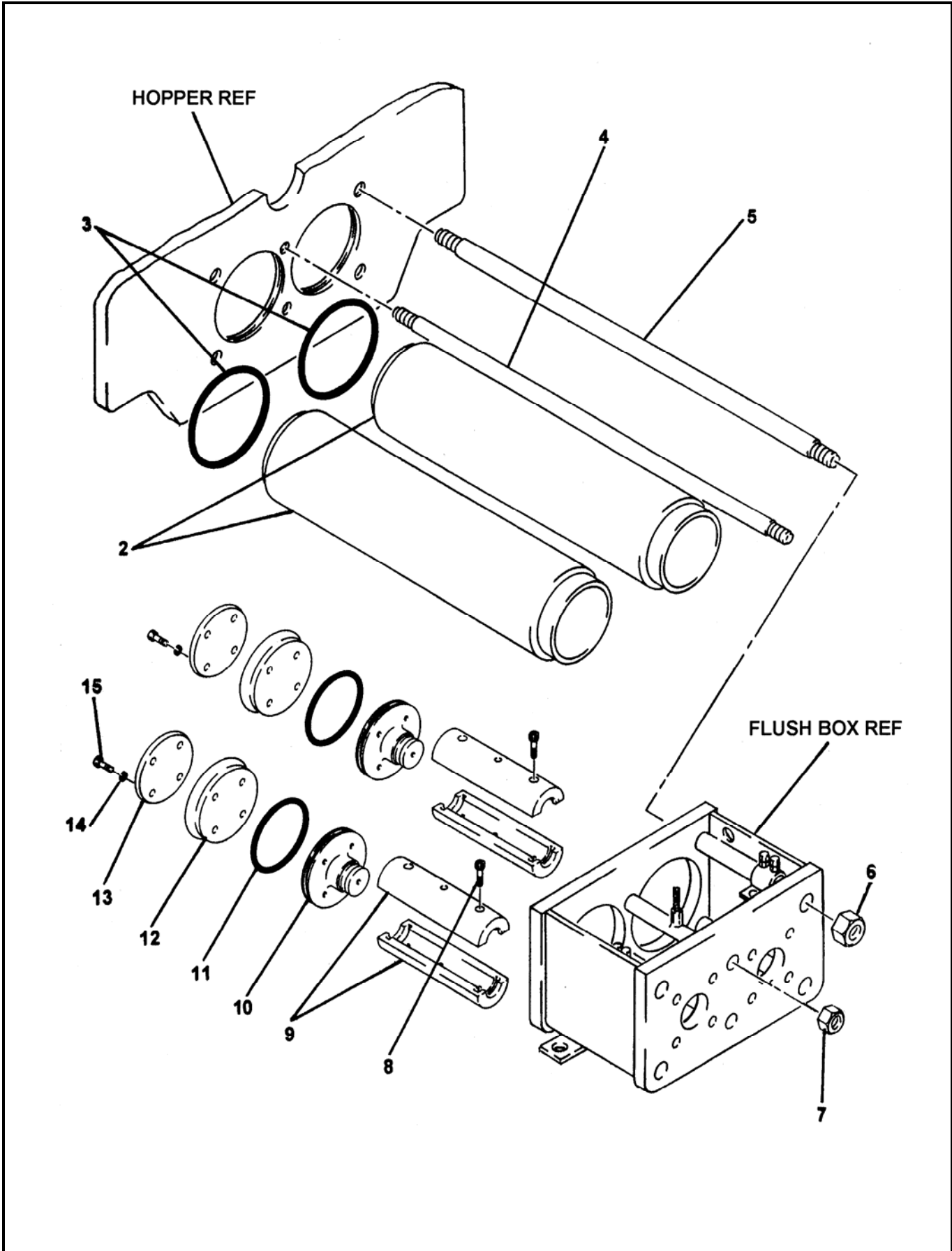

REVISION:



MATERIAL CYLINDER ASSEMBLY

C50HP
PARTS
GROUP 60
FIGURE 04
PAGE 02

ITEM NO.	REED'S PARTS NO.	DESCRIPTION					QTY
		1	2	3	4	5	
-1	86311	Assembly, Material Cylinder (See Group 60, Figure 01 for DET)					Ref
2	86147	• Cylinder, Material					2
3	86149	• O-Ring, Material Cylinder					2
4	86023	• Rod, Tie					2
5	86022	• Rod, Tie					4
6		• Nut, Hex (attaching parts)					4
7		• Nut, Hex (attaching parts)					2
8		• Screw, Cap					4
9	86024	• Coupling, Piston					2
10	77194	• Adapter, 6 Inch Piston					2
11	77120	• Band, Guide 6 Inch					2
12	70048	• Cup, 6 Inch Piston					2
13	70057	• Plate, 6 Inch Piston					2
14		• Washer, Star (attaching parts)					8
15		• Bolt, Hex (attaching parts)					8

DASH(-) ITEM NOT ILLUSTRATED



FLUSH BOX ASSEMBLY

C50HP
PARTS
GROUP 60
FIGURE 05
PAGE 01

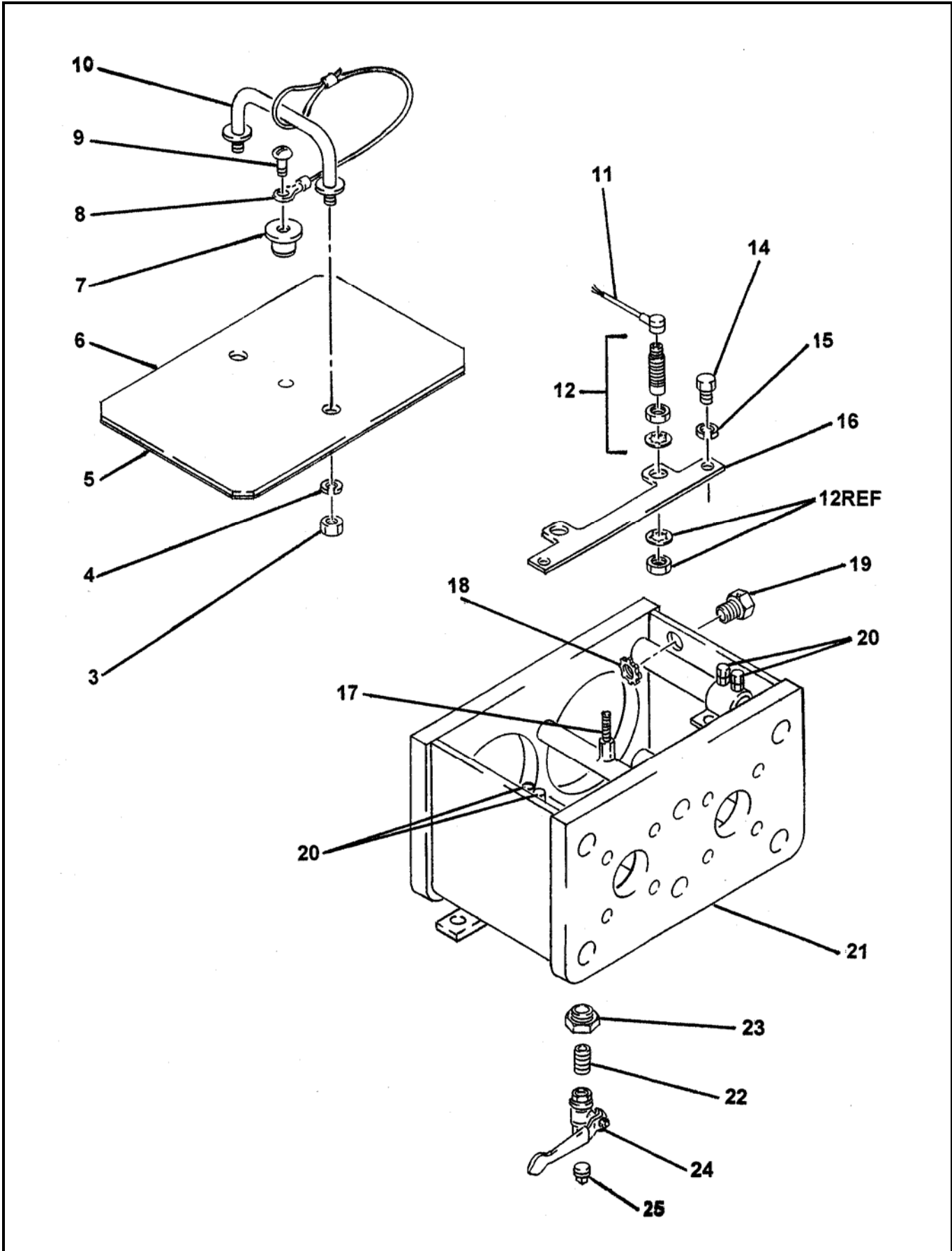

REVISION:



FLUSH BOX ASSEMBLY

C50HP
PARTS
GROUP 60
FIGURE 05
PAGE 02

ITEM NO.	REED'S PARTS NO.	DESCRIPTION	QTY
		1 2 3 4 5	
-1	60-05	Assembly, Flushbox (See Group 60, Figure 01 for NHA)	Ref
2	86106	• Assembly, Flush Box Cover	1
3		• • Nut, Hex	2
4		• • Washer, Lock	2
5	13257	• • Weatherstrip, Rubber	A/R
6	86010	• • Weldment, Flush Box Cover	1
7	86105	• • Knob	1
8	800418	• • Lanyard	1
9		• • Screw, Rd Hd	1
10	79056	• • Handle, Splash Guard	1
11	77998	• Cable, Proximity Switch	2
12	77990	• Sensor, Proximity Switch	2
-13	86307	• Assembly, 6 Inch Flush Box Group	1
14		• • Bolt, Hex	2
15		• • Washer, Lock	2
16	86006	• • Bracket, Proximity Switch	1
17	86665	• • Stud	1
18	10528	• • Nut	1
19	10522	• • Conduit, Fitting (Proximity wires must be removed to replace fitting)	1
20		• • Bolt, Hex	4
21	86093	• • Weldment, 6 Inch Flush Box	1
22	10224	• Bushing, Hex	1
23	10355	• Nipple	1
24	56413	• Valve, Ball	1
25	74944	• Plug	1
		DASH (-) ITEM NOT ILLUSTRATED	

REVISION:



HYDRAULIC DRIVE CYLINDER ASSEMBLY

C50HP
PARTS
GROUP 60
FIGURE 06
PAGE 01

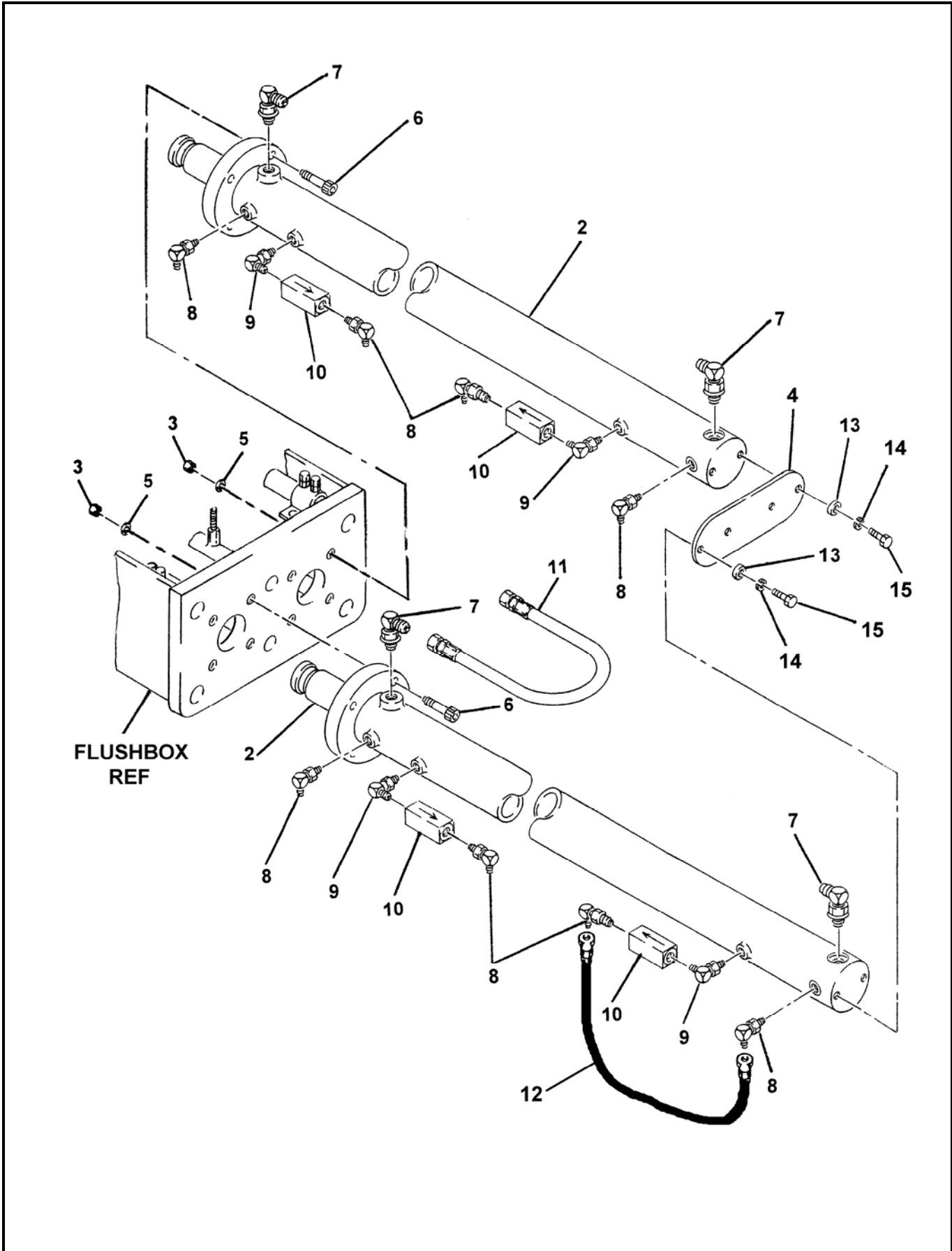

REVISION:



HYDRAULIC DRIVE CYLINDER ASSEMBLY

C50HP
PARTS
GROUP 60
FIGURE 06
PAGE 02

ITEM NO.	REED'S PARTS NO.	DESCRIPTION	QTY
		1 2 3 4 5	
-1	60-06	Assembly, Hydraulic Drive Cylinder (See Group 60, Figure 01 for NHA)	Ref
2	86222	• Sub-Assembly, Hydraulic Drive Cylinder (See Group 60, Figure 07 for DET)	1
3		• Nut, Hex (attaching parts)	8
4	86544	• Plate, End	1
5		• Washer, SAE (attaching parts)	8
6		• Bolt (attaching parts)	8
7		• Fitting, 90°	4
8		• Fitting, 90°	8
9		• Fitting, 90°	4
10	78961	• Valve, Check	4
11	85427	• Assembly, Tube	1
12	85659-002	• Assembly, Hose	4
13		• Washer, Flat (attaching parts)	4
14		• Washer, Lock (attaching parts)	4
15		• Bolt, Hex (attaching parts)	4
		DASH (-) ITEM NOT ILLUSTRATED	

REVISION:



HYDRAULIC DRIVE CYLINDER SUB-ASSEMBLY

C50HP
PARTS
GROUP 60
FIGURE 07
PAGE 01

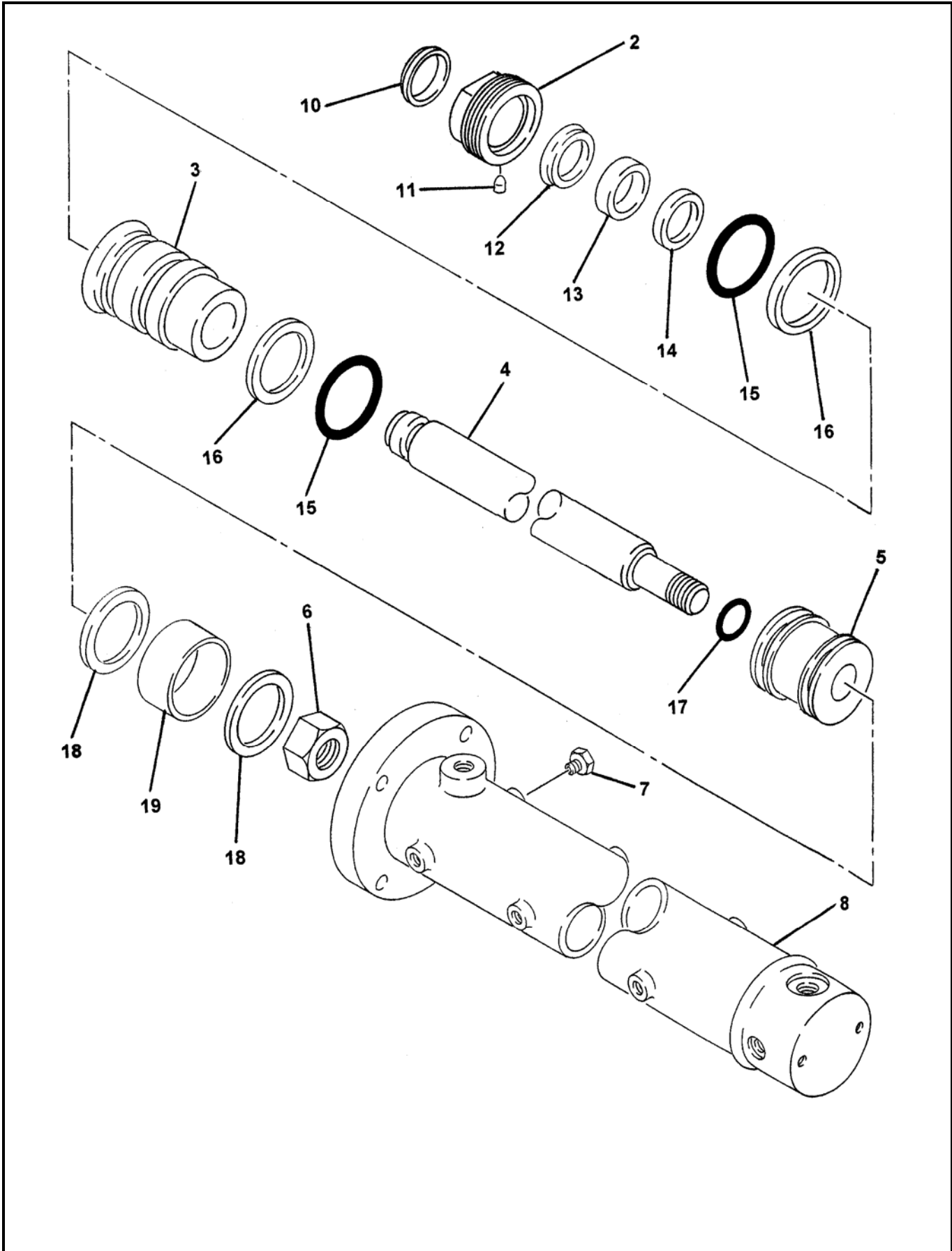

REVISION:



**HYDRAULIC DRIVE
CYLINDER SUB-ASSEMBLY**

**C50HP
PARTS
GROUP 60
FIGURE 07
PAGE 02**

ITEM NO.	REED'S PARTS NO.	DESCRIPTION	QTY
		1 2 3 4 5	
-1	86222	Sub-Assembly, Hydraulic Drive Cylinder (See Group 60, Figure 06 for NHA)	Ref
2		• Nut, Retaining	1
3		• Rod, Cylinder	1
4		• Retainer	1
5		• Piston	1
6		• Weldment, Cylinder Barrel	1
-7	86222-SKTX	• Kit, Seal	1
8		•• Wiper, Rod	1
9		•• Bearing, Rod Bronze	1
10		•• Seal, Rod	1
11		•• Seal, Static	1
12		•• Seal, Static	1
13		•• Seal, Piston	2
14		•• Ring, Wear	2
15		•• Nut, Piston	1
16		• Plug	4

DASH (-) ITEM NOT ILLUSTRATED



TRAILER MOUNTED PUMP 02 MODEL *C50HP*
ILLUSTRATED PARTS MANUAL

C50HP
PARTS
GROUP 60
FIGURE 08
PAGE 01

THIS PAGE INTENTIONALLY LEFT BLANK.

REED TRAILER MOUNTED CONCRETE PUMP 02 MODEL C50HP ILLUSTRATED PARTS MANUAL GROUP 70 FRAME INSTALLATION CONTAINS THE FOLLOWING FIGURES:

- FIGURE 00** TABLE OF CONTENTS
- FIGURE 01** FRAME INSTALLATION
- FIGURE 02** HYDRAULIC OUTRIGGER CYLINDER ASSEMBLY
- FIGURE 03** HUB AND BRAKE ASSEMBLY
- FIGURE 04** NON-OPERATOR SIDE ELECTRIC BRAKE ASSEMBLY
- FIGURE 05** OPERATOR SIDE ELECTRIC BRAKE ASSEMBLY

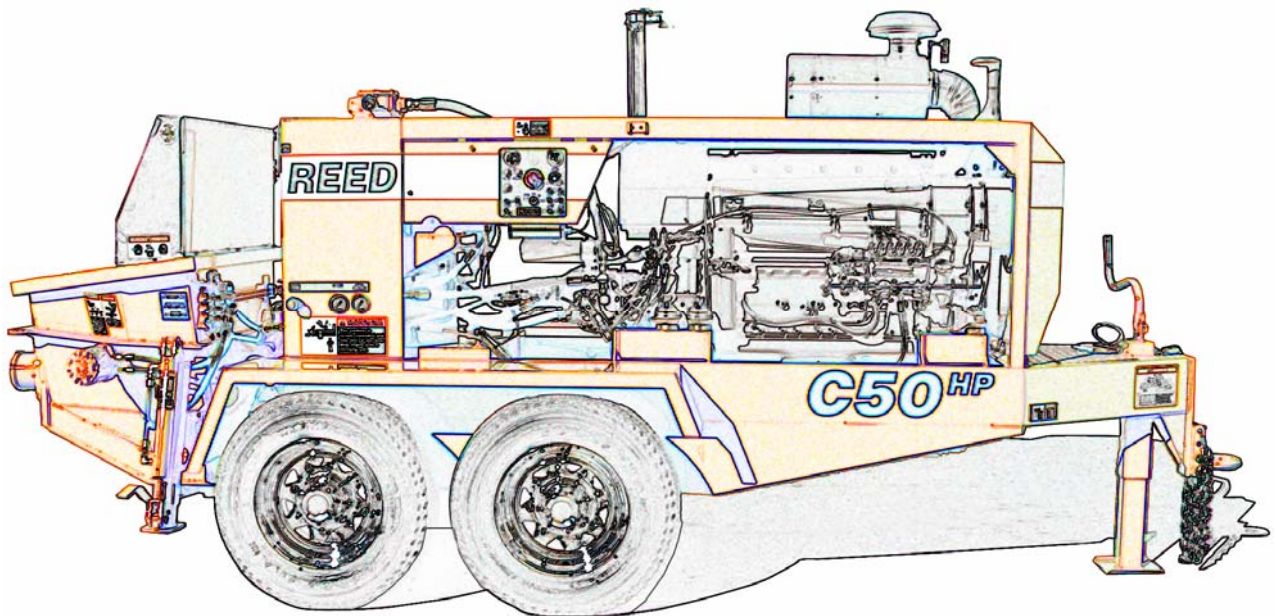



FRAME INSTALLATION

C50HP
PARTS
 GROUP 70
 FIGURE 01
 PAGE 02

ITEM NO.	REED'S PARTS NO.	DESCRIPTION	QTY
		1 2 3 4 5	
-1	70-01	Installation, Frame (See Group 10, Figure 01 for NHA)	Ref
2	86553	• Weldment, Outrigger Inner	2
3	85595	• Pin	2
4	800418	• Lanyard, Pin	2
5	86574	• Assembly, Hydraulic Outrigger Cylinder (See Group 70, Figure 02 for REF)	2
-6	85685	• Tube, Hydraulic Outrigger	1
-7	88686	• Tube, Hydraulic Outrigger	1
-8	801902-020	• Clamp, Tube	4
9	72948	• Light, Tail	2
10	85394	• Weldment, Right Fender	1
-11	85395	• Weldment, Left Fender	1
-12	85438	• Tube, Hydraulic Shift Cylinder	1
-13	85439	• Tube, Hydraulic Shift Cylinder	1
14	85406	• Cover, Front	1
15	86532	• Assembly, Trailer Wiring Harness (See Schematic Section for REF)	1
16	72813	• Grommet, Tool Box	1
17	72949	• Grommet, Trailer	5
18	85391	• Cover, Control Box	1
19	77179	• Weldment, Lifting Structure	1
20	87086	• Chain Assembly	2
20A	86730	•• Chain-5FT	2
21	87085	•• Shackle-Connector, Chain	4
22	87002	• Assembly, Frame	1
23	87037	•• Drawbar	1
24	85123	•• Weldment, Jack	1
25	86991	•• Weldment, Frame	1
26	85636	••• Cover, Tool Box	1
27	85383	•• Axle	2
28	70-03	•• Assembly, Hub and Brake (See Group 70, Figure 03 for DET)	4
29	85423	•• Assembly, Wheel and Tire	4
-30	10196	• Lok, Trim 1.5 FT	1
-31	73613	• Seal, Trim 6 FT	1
-32	13257	• Weatherstripping-24 Inches	1
-33	85405	• Weatherstripping-24 Inches	1
DASH (-) ITEM NOT ILLUSTRATED			

REVISION:



HYDRAULIC OUTRIGGER CYLINDER ASSEMBLY

C50HP
PARTS
GROUP 70
FIGURE 02
PAGE 01

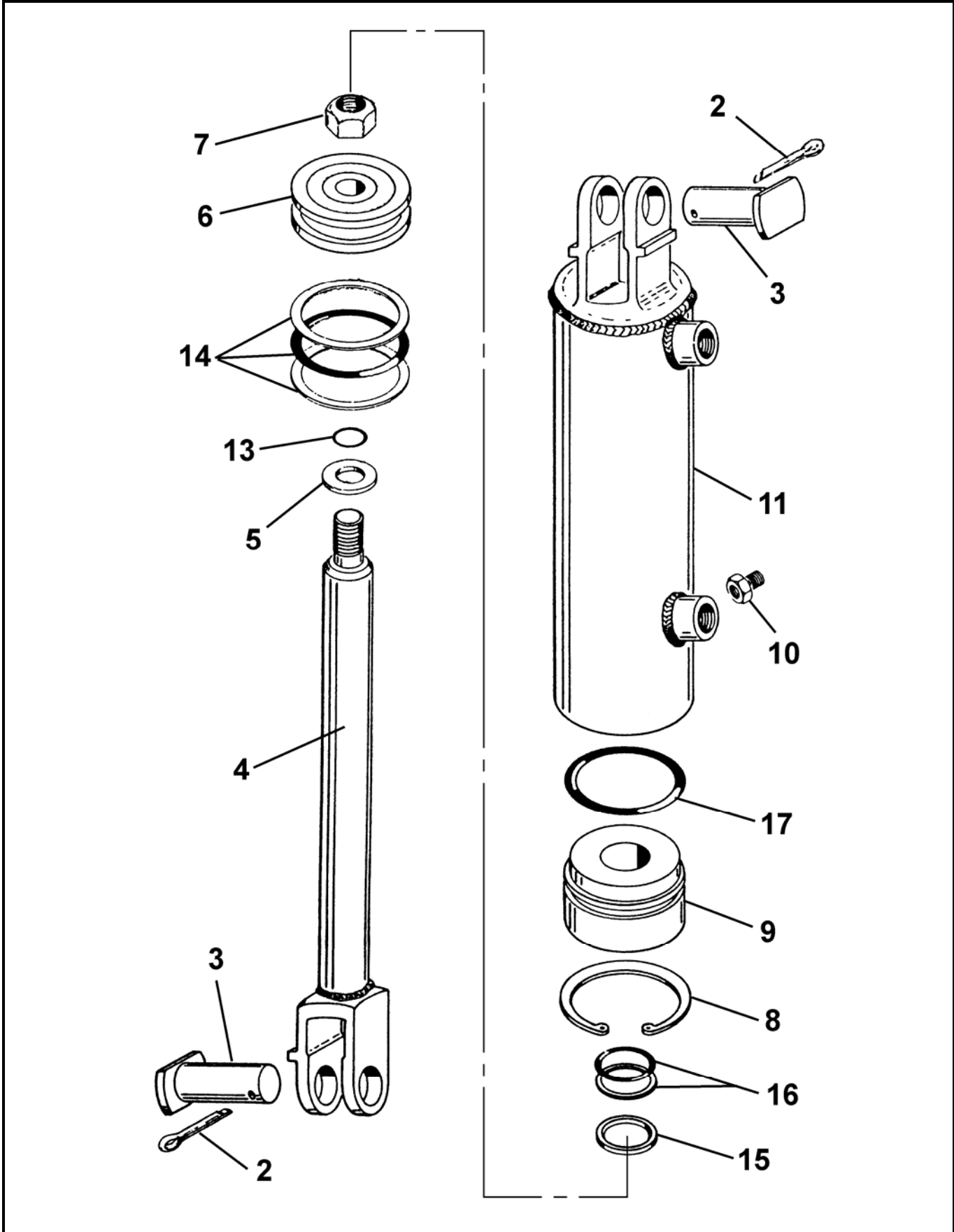

REVISION:



HYDRAULIC OUTRIGGER CYLINDER ASSEMBLY

C50HP
PARTS
GROUP 70
FIGURE 02
PAGE 02

ITEM NO.	REED'S PARTS NO.	DESCRIPTION	QTY
		1 2 3 4 5	
-1	86574	Assembly, Hydraulic Outrigger Cylinder (See Group 70, Figure 01 for NHA)	Ref
2		• Pin, Safety	2
3		• Pin, Clevis	2
4		• Assembly, Shaft	1
5		• Washer, Steel	1
6		• Piston	1
7		• Nut, Piston Lock	1
8		• Ring, Head Lock	1
9		• Head	1
10		• Screw, Head Set	1
11		• Assembly, Tube	1
-12	86574-SK	• Kit, Seal	1
13		•• O-Ring, Small	1
14		•• Sub-Assembly, Piston O-Ring	1
15		•• Wiper, Rod	1
16		•• Packing, Shaft (Pair)	1
17		•• O-Ring, Head	1
		DASH (-) ITEM NOT ILLUSTRATED	

REVISION:



HUB AND BRAKE ASSEMBLY

C50HP
PARTS
GROUP 70
FIGURE 03
PAGE 01

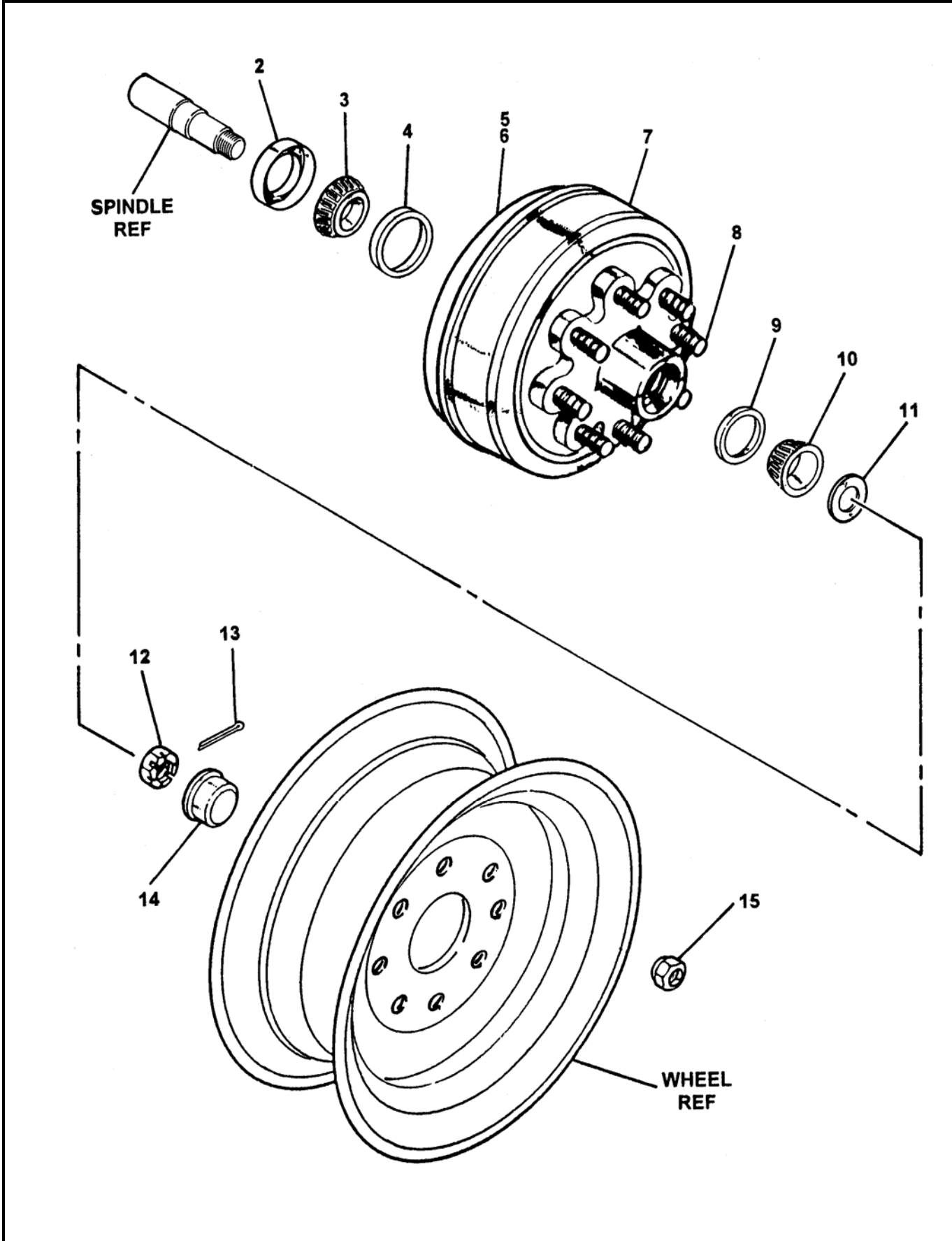

REVISION:



HUB AND BRAKE ASSEMBLY

C50HP
PARTS
GROUP 70
FIGURE 03
PAGE 02

ITEM NO.	REED'S PARTS NO.	DESCRIPTION	QTY
		1 2 3 4 5	
-1	70-03	Assembly, Hub and Brake (See Group 70, Figure 01 for NHA)	Ref
2	86709	• Seal, Double Lip Grease	2
3	71094	• Bearing, Inner	2
4	71092	• Race, Inner Bearing	2
5	71056-L	• Assembly, Non-Operator Electric Brake (See Group 70, Figure 04 for DET)	1
6	71056-R	• Assembly, Operator Electric Brake (See Group 70, Figure 05 for DET)	1
7	86717	• Assembly, Drum & Hub	2
8	86716	• Stud, Wheel	16
9	86710	• Race, Outer Bearing	2
10	71098	• Bearing, Outer	2
11	86711	• Washer, Spindle	2
12	86712	• Nut, Spindle	2
13	86713	• Pin, Cotter	2
14	86714	• Cap, Dust	2
15	86715	• Nut, Wheel	16
		DASH (-) ITEM NOT ILLUSTRATED	

REVISION:



NON OPERATOR SIDE ELECTRIC BRAKE ASSEMBLY

C50HP
PARTS
GROUP 70
FIGURE 04
PAGE 01

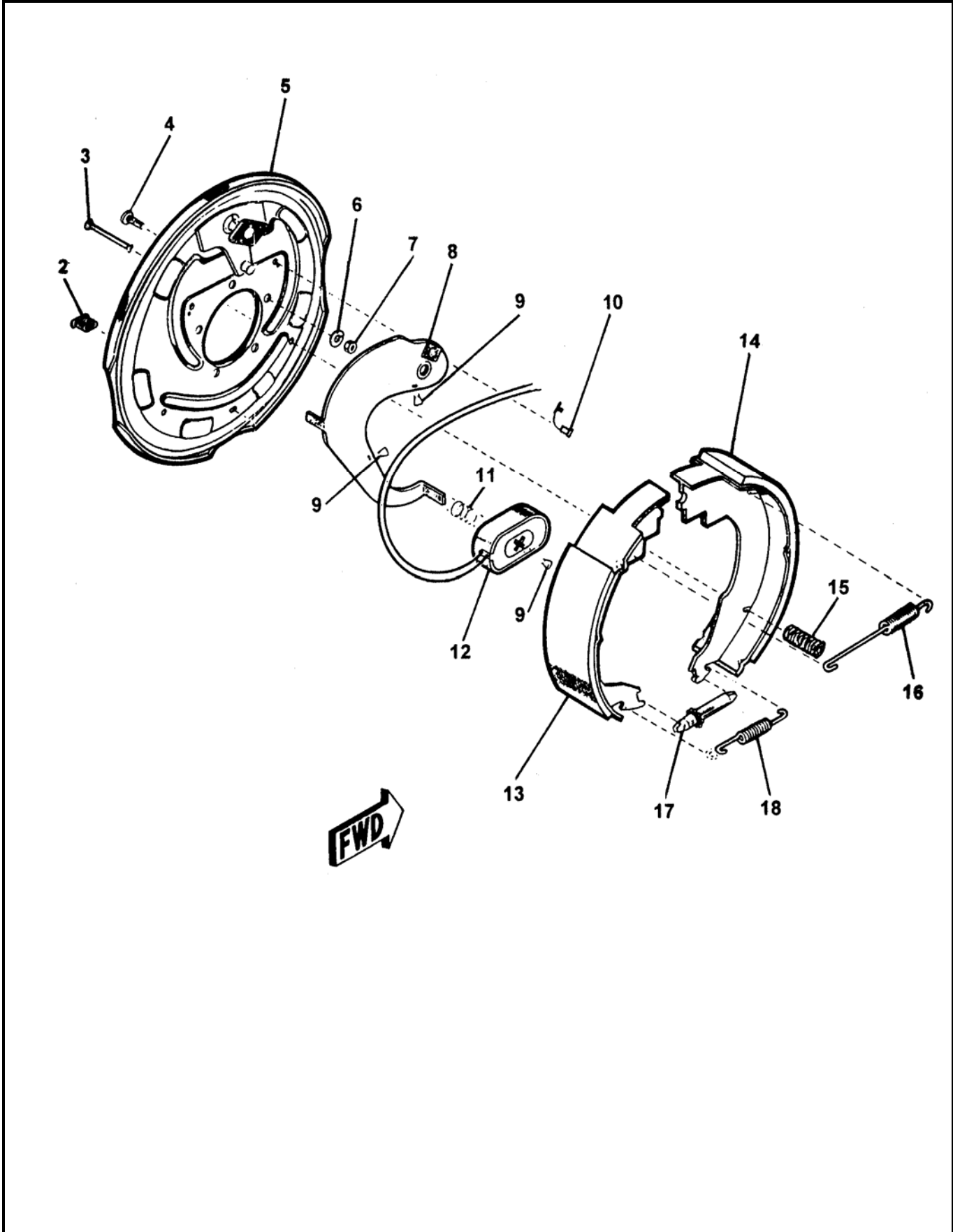

REVISION:



NON OPERATOR SIDE ELECTRIC BRAKE ASSEMBLY

C50HP
PARTS
GROUP 70
FIGURE 04
PAGE 02

ITEM NO.	REED'S PARTS NO.	DESCRIPTION	QTY
		1 2 3 4 5	
-1	71056-L	Assembly, Non-Operator Side Electric Brake (See Group 70, Figure 03 for NHA)	Ref
2		• Slot, Plug Adjust	1
3		• Pin, Shoe Hold down	1
4		• Stud, Brake Mounting	5
5		• Assembly, Baking Plate	1
6		• Washer, Brake Lock	5
7		• Nut, Brake Mounting	5
8		• Lever, Non-Operator Side	1
9		• Clip, Wire and Magnet	3
10		• Relief, Strain	2
11		• Spring, Magnet	1
12		• Sub-Assembly, Magnet	1
13		• Shoe and Lining, Primary	1
14		• Shoe and Lining, Secondary	1
15		• Spring, Shoe Hold down	1
16		• Spring, Shoe Retractor	1
17		• Sub-Assembly, Adjuster Screw	1
18		• Spring, Adjuster Screw	1
		DASH (-) ITEM NOT ILLUSTRATED	

REVISION:



OPERATOR SIDE ELECTRIC BRAKE ASSEMBLY

C50HP
PARTS
GROUP 70
FIGURE 05
PAGE 01

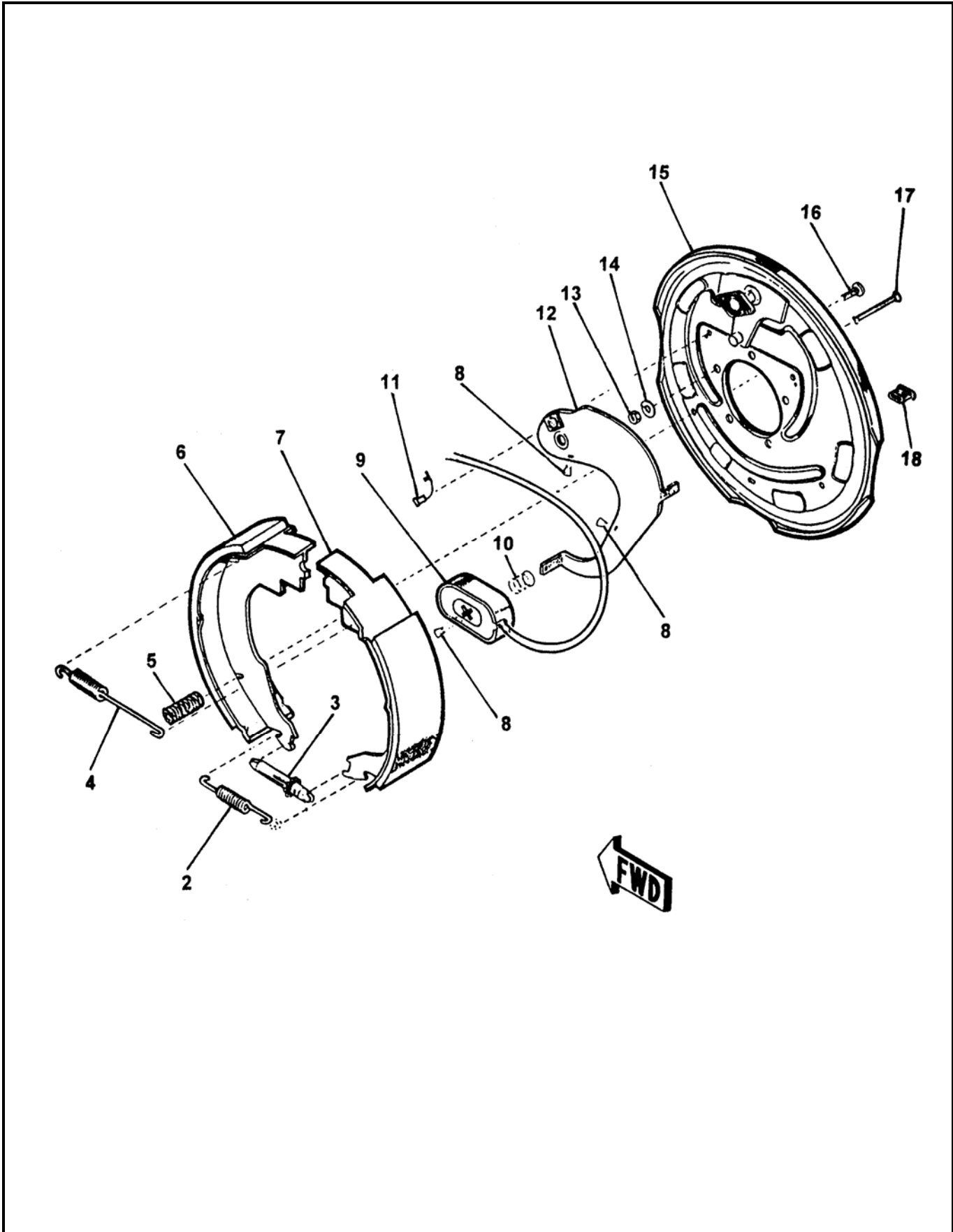

REVISION:



OPERATOR SIDE ELECTRIC BRAKE ASSEMBLY

C50HP
PARTS
GROUP 70
FIGURE 05
PAGE 02

ITEM NO.	REED'S PARTS NO.	DESCRIPTION	QTY
		1 2 3 4 5	
-1	71056-R	Assembly, Operator Side Electric Brake (See Group 70, Figure 03 for NHA)	Ref
2		• Spring, Adjuster Screw	1
3		• Sub-Assembly, Adjuster Screw	1
4		• Spring, Shoe Retractor	1
5		• Spring, Shoe Hold down	1
6		• Shoe and Lining, Secondary	1
7		• Shoe and Lining, Primary	1
8		• Clip, Wire and Magnet	3
9		• Sub-Assembly, Magnet	1
10		• Spring, Magnet	1
11		• Relief, Strain	2
12		• Lever, Operator Side	1
13		• Nut, Brake Mounting	5
14		• Washer, Brake Lock	5
15		• Assembly, Baking Plate	1
16		• Stud, Brake Mounting	5
17		• Pin, Shoe Hold down	1
18		• Slot, Plug Adjust	1
		DASH (-) ITEM NOT ILLUSTRATED	

REVISION:



TRAILER MOUNTED PUMP 02 MODEL C50HP
GROUP 70 FRAME INSTALLATION

C50HP
PARTS
GROUP 70
FIGURE 06
PAGE 01

THIS PAGE INTENTIONALLY LEFT BLANK.

REED TRAILER MOUNTED CONCRETE PUMP 02 MODEL **C50HP** ILLUSTRATED PARTS MANUAL GROUP 80 OPTIONAL INSTALLATION CONTAINS THE FOLLOWING FIGURES:

FIGURE 00	TABLE OF CONTENTS
FIGURE 01	OPTIONAL INSTALLATION
FIGURE 02	LUBE SYSTEM ASSEMBLY
FIGURE 03	12 VOLT LUBE PUMP ASSEMBLY
FIGURE 04	HOPPER VIBRATOR ASSEMBLY
FIGURE 05	CHROME WHEEL ASSEMBLY
FIGURE 06	OPTIONAL TOOL KIT ASSEMBLY
FIGURE 07	ACTUATOR BRAKES ASSEMBLY
FIGURE 08	WASH PUMP ASSEMBLY
FIGURE 09	WASH WATER PUMP ASSEMBLY
FIGURE 10	WASH PUMP MOTOR ASSEMBLY
FIGURE 11	ACCUMULATOR CHARGE KIT
FIGURE 12	NON-OPERATOR SIDE HYDRAULIC BRAKE ASSEMBLY
FIGURE 13	OPERATOR SIDE HYDRAULIC BRAKE ASSEMBLY
FIGURE 14	1 SPOOL VALVE ASSEMBLY
FIGURE 15	1 SPOOL VALVE SUB-ASSEMBLY
FIGURE 16	2 SPOOL VALVE ASSEMBLY
FIGURE 17	2 SPOOL VALVE SUB-ASSEMBLY

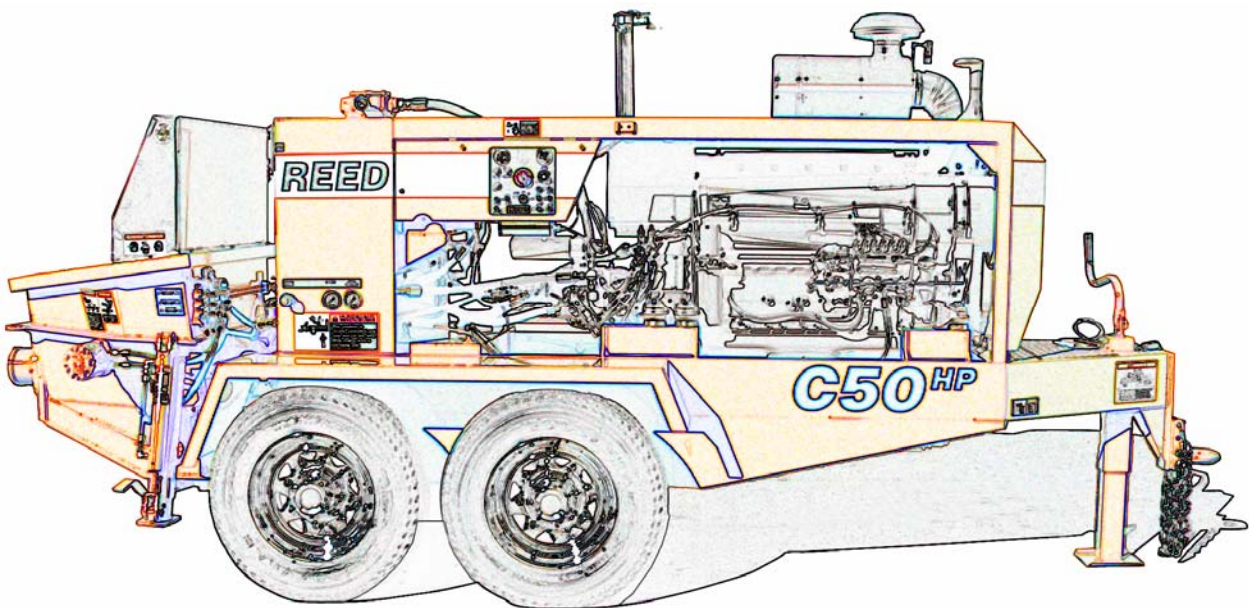



OPTIONAL INSTALLATION

C50HP
PARTS
GROUP 80
FIGURE 01
PAGE 01

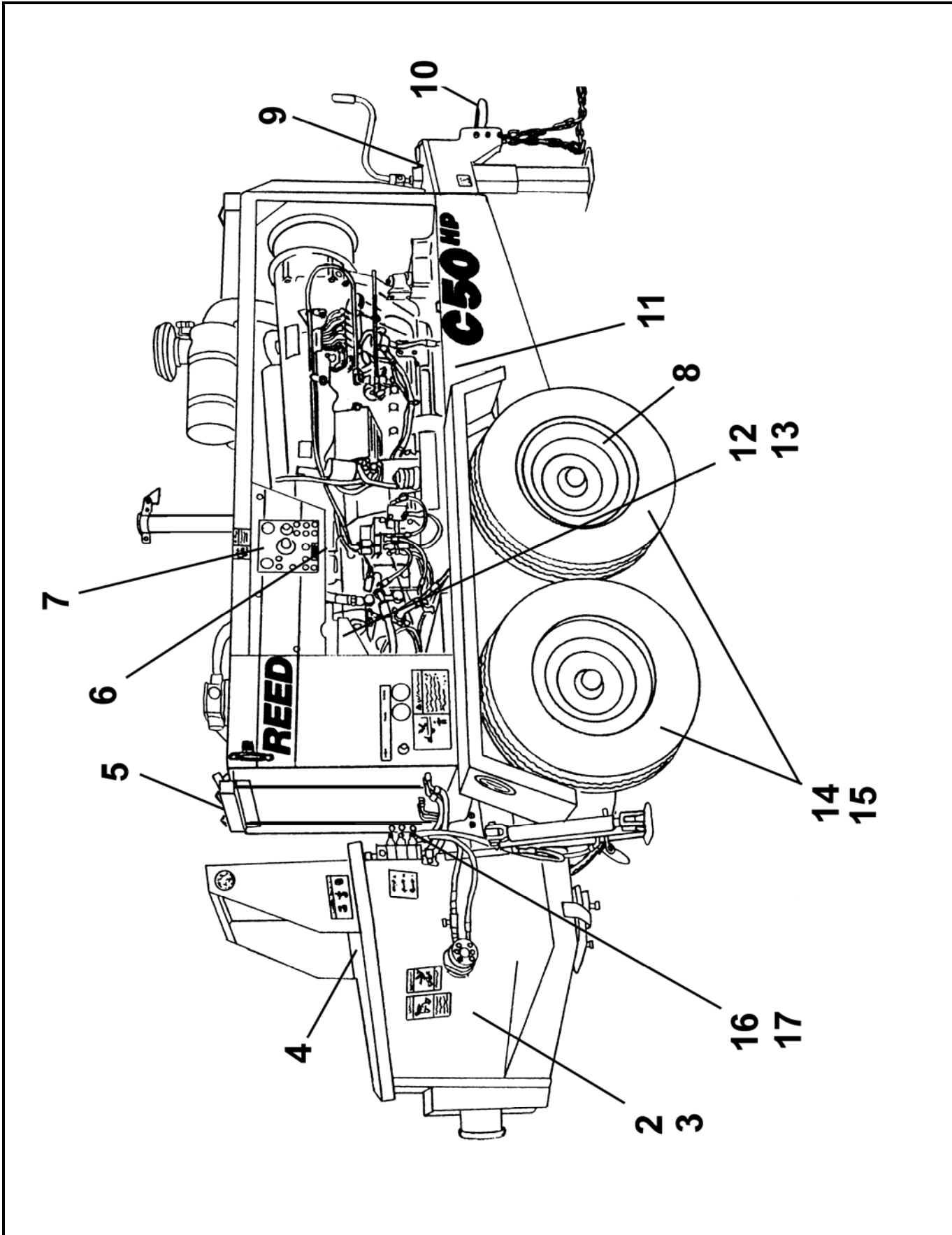

REVISION:



OPTIONAL INSTALLATION

C50HP
PARTS
GROUP 80
FIGURE 01
PAGE 02

ITEM NO.	REED'S PARTS NO.	DESCRIPTION	QTY
		1 2 3 4 5	
-1	80-01	Installation, Optional (See Group 10, Figure 01 and Figure 02 for NHA)	Ref
2	80-02	• Assembly, Lube System (See Group 80, Figure 02 for DET)	1
3	78736	• Assembly, Lube Pump (See Group 80, Figure 03 for DET)	1
4	86926	• Assembly, Hopper Vibration (See Group 80, Figure 04 for DET)	1
5	86863	• Assembly, Optional Lifting	1
6	85818	• Assembly, Radio Remote Control (See Group 50, Figure 04 for REF)	1
7	85774	• Assembly, Stroke Counter	1
8	80-05	• Assembly, Chrome Wheel (See Group 80, Figure 05 for DET)	1
9	79020	• Assembly, Optional Tool Kit (See Group 80, Figure 07 for DET)	1
10	87191	• Assembly, Actuator Brake (See Group 80, Figure 08 for DET)	1
11	86399	• Assembly, Wash Pump (See Group 80, Figure 09 for DET)	1
12	71460	• Kit, Accumulator Charge (See Group 80, Figure 12 for DET)	1
13	30-11	• Kit, Bladder Repair (See Group 30, Figure 11 for REF)	1
14	80-13	• Assembly, Non-Operator Side Hydraulic Brake (See Group 80, Figure 13 for DET)	2
15	80-14	• Assembly, Operator Side Hydraulic Brake (See Group 80, Figure 14 for DET)	2
16	80-15	• Assembly, 1 Spool Valve (See Group 80, Figure 15 for DET)	1
17	80-17	• Assembly, 2 Spool Valve (See Group 80, Figure 17 for DET)	1
		DASH (-) ITEM NOT ILLUSTRATED	

REVISION:



LUBE SYSTEM ASSEMBLY(OPTIONAL)

C50HP
PARTS
GROUP 80
FIGURE 02
PAGE 01



REVISION:



LUBE SYSTEM ASSEMBLY(OPTIONAL)

C50HP
PARTS
GROUP 80
FIGURE 02
PAGE 02

ITEM NO.	REED'S PARTS NO.	DESCRIPTION	QTY
		1 2 3 4 5	
-1	80-02	Assembly, Lube System (See Group 80, Figure 01 for NHA)	Ref
2		• Assembly, Lube Hose	A/R
3	75436	• Clamp, Pipe	3
4	72355	• Block, 6 Station Lube System	1
5	78532	• Gun, Grease	1
6		•• Plug	1
7		•• Handle, Pumping	1
8		•• Tube, Container	1
9		•• Cap, Tube	1
10		•• Handle, Follower	1
11		•• Spacer	1
12		•• Rod, Follower	1
13		•• Spring	1
14		•• Sub-Assembly, Follower	1
15		•• Packing, Container	1
16		•• Gasket	1
17		•• Housing, Spring	1
18		•• Spring	1
19		•• Ball, Check	1
20		•• Extension, Nozzle	1
21		•• Coupler, Hydraulic	1
22		•• Nipple, Filler (Optional Item)	1
		DASH (-) ITEM NOT ILLUSTRATED	

REVISION:



LUBE PUMP ASSEMBLY

C50HP
PARTS
GROUP 80
FIGURE 03
PAGE 01

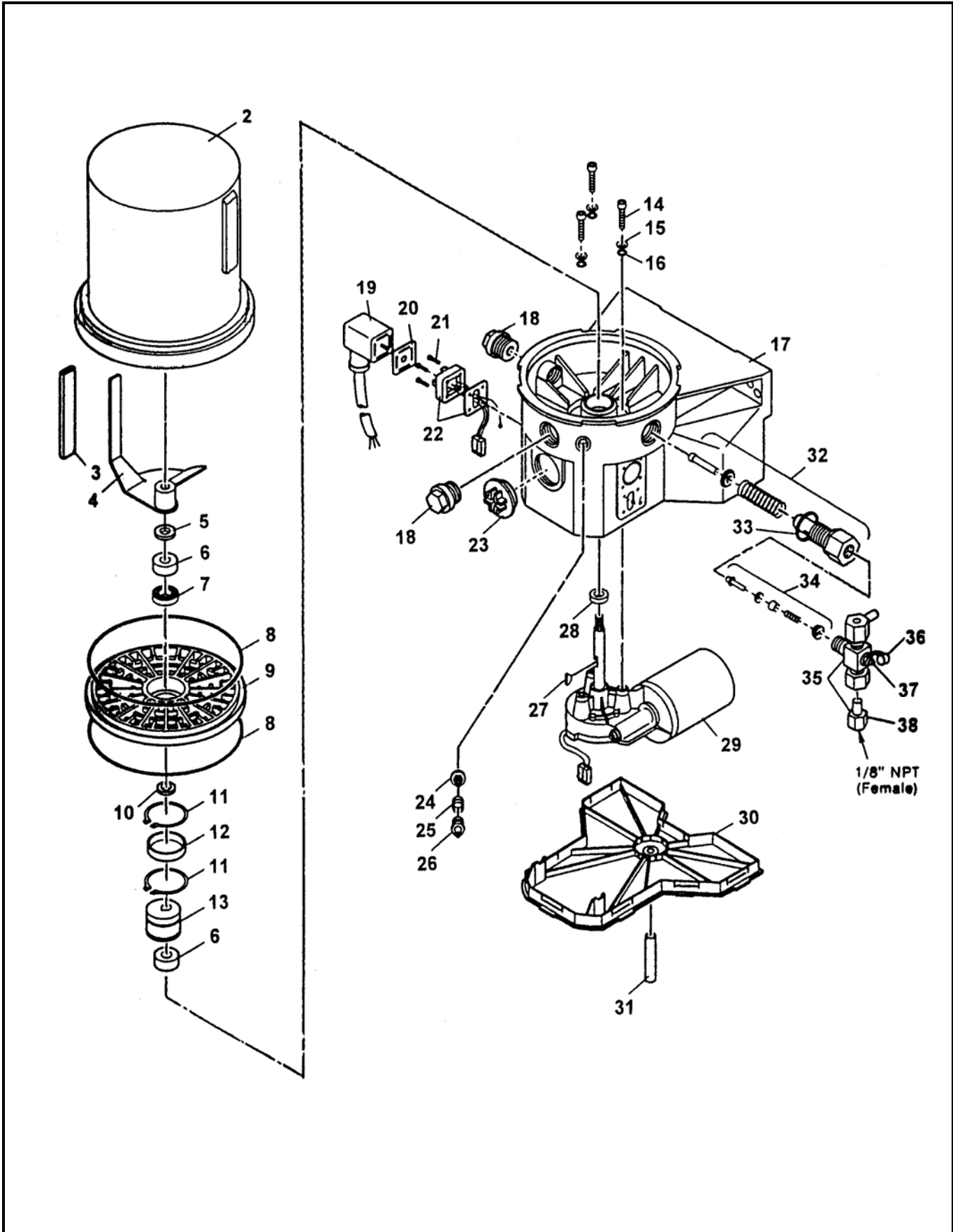

REVISION:



LUBE PUMP ASSEMBLY

C50HP
PARTS
GROUP 80
FIGURE 03
PAGE 02

ITEM NO.	REED'S PARTS NO.	DESCRIPTION	QTY
		1 2 3 4 5	
-1	78736	Assembly, Lube Pump (See Group 80, Figure 01 for NHA)	Ref
2		• Reservoir	1
3		• House	1
4		• Paddle, Stirring	1
5		• Washer	1
6		• Ring, Bearing	2
7		• Bearing	1
8		• O-Ring	2
9		• Plate, Intermediate	1
10		• Shim	1
11		• Ring, Snap	2
12		• Ring, Inner	1
13		• Cam, Eccentric	1
14		• Screw	3
15		• Washer	3
16		• O-Ring	3
17		• Housing, Pump	1
18		• Plug, Closure	2
19		• Socket with Cord	1
20		• Packing, Flat	1
21		• Screw	4
22		• Plug	1
23		• Plug, Sealing	1
24		• Insert, Filter	1
25		• Spring	1
26		• Fitting, Grease	1
27		• Key, Woodruff	1
28		• Seal, Radial	1
29		• Motor, 12 VDC	1
30		• Cover, Housing	1
31		• Hose	1
32		• Element, Pump	1
33		• Gasket	1
34		• Valve, Check	1
35		• Assembly, Pressure Reliefs	1
36		• Cap, Grease	1
37		• Fitting, Grease	1
38		• Assembly, Adapter for Relief	1
		DASH (-) ITEM NOT ILLUSTRATED	

REVISION:



HOPPER VIBRATOR ASSEMBLY

C50HP
PARTS
GROUP 80
FIGURE 04
PAGE 01

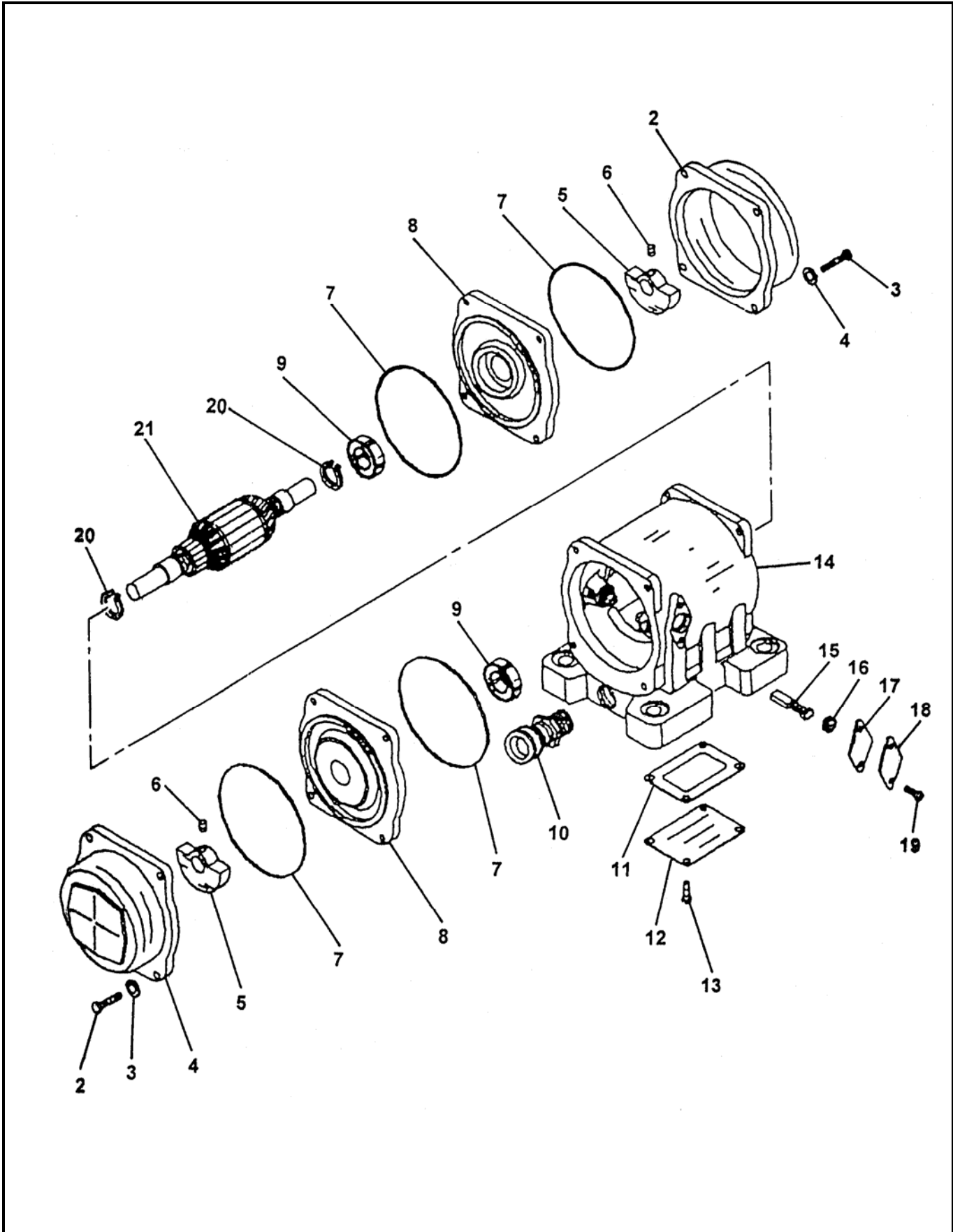

REVISION:



HOPPER VIBRATOR ASSEMBLY

C50HP
PARTS
GROUP 80
FIGURE 04
PAGE 02

ITEM NO.	REED'S PARTS NO.	DESCRIPTION	QTY
		1 2 3 4 5	
-1	86926	Assembly, Hopper Vibrator (See Group 80, Figure 01 for NHA)	Ref
2		• Cap, End	2
3		• Bolt (attaching parts)	8
4		• Washer, Lock (attaching parts)	8
5		• Weight	2
6		• Screw, Set (attaching parts)	2
7		• O-Ring	4
8		• Bell, End	2
9		• Bearing	2
10		• Holder, Cord	1
11		• Gasket	1
12		• Cover, Box	1
13		• Screw (attaching parts)	4
14		• Sub-Assembly, Housing	1
15		• Brush	1
16		• Cap, Brush	2
17		• Gasket	2
18		• Cover, Brush	2
19		• Screw (attaching parts)	4
20		• Ring, Snap	2
21		• Assembly, Armature	1
		DASH (-) ITEM NOT ILLUSTRATED	

REVISION:



CHROME WHEEL ASSEMBLY

C50HP
PARTS
GROUP 80
FIGURE 05
PAGE 01



REVISION:

CHROME WHEEL ASSEMBLY



ITEM NO.	REED'S PARTS NO.	DESCRIPTION	QTY
		1 2 3 4 5	
-1	80-05	Assembly, Chrome Wheel (See Group 80, Figure 01 for NHA)	Ref
2	73212	• Assembly, Chrome Wheel and Tire	4
3	73554	•• Tire	1
4	73555	•• Wheel	1
5	85383	• Axle	2



OPTIONAL TOOL KIT

C50HP
PARTS
GROUP 80
FIGURE 06
PAGE 01

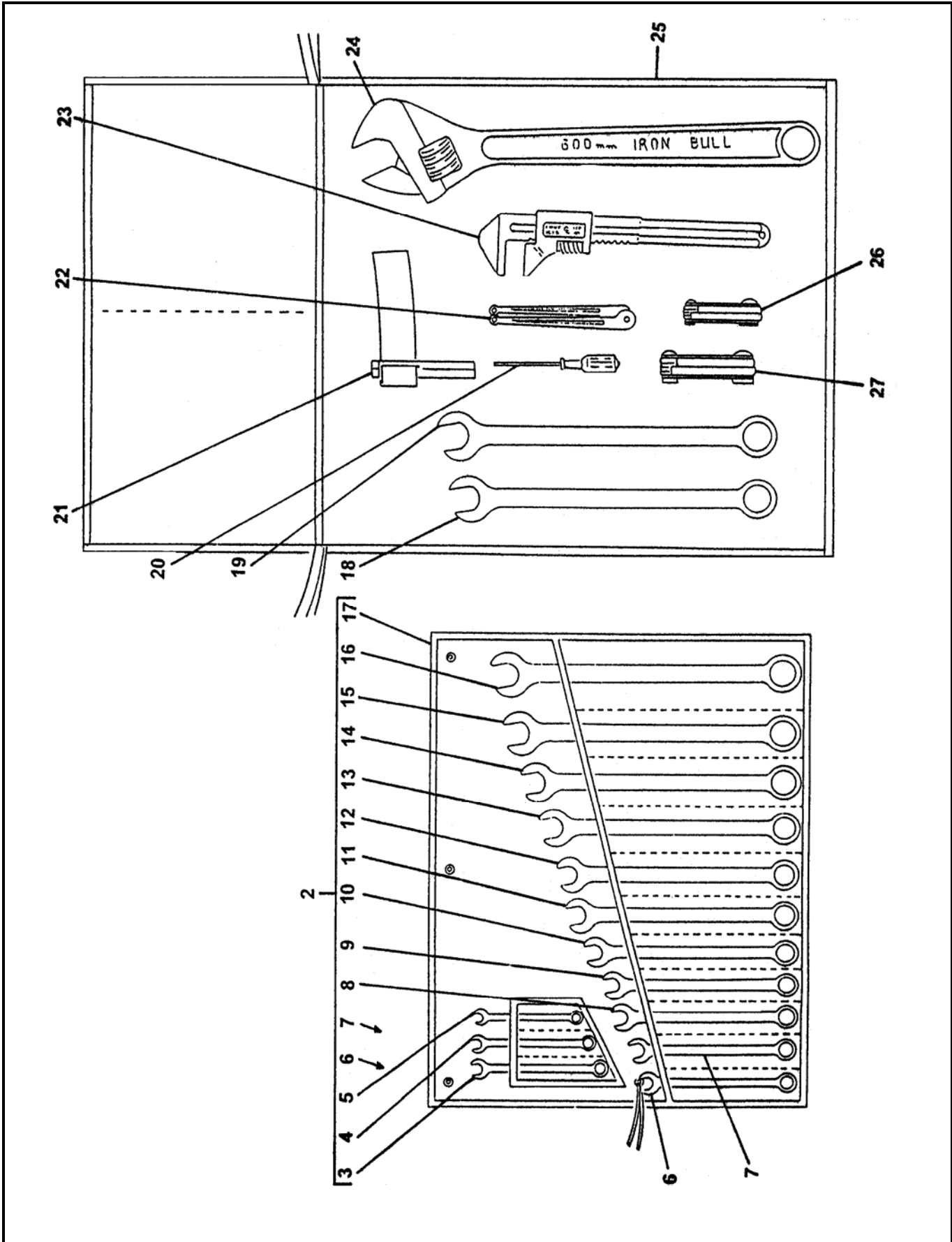

REVISION:



OPTIONAL TOOL KIT

ITEM NO.	REED'S PARTS NO.	DESCRIPTION	QTY
		1 2 3 4 5	
-1	79020	Assembly, Optional Tool Kit (See Group 80, Figure 01 for NHA)	Ref
2	79037	• Kit, Wrench	1
3		•• Wrench, 1/2 Inch	1
4		•• Wrench, 7/16 Inch	1
5		•• Wrench, 3/8 Inch	1
6		•• Wrench, 9/16 Inch	1
7		•• Wrench, 5/8 Inch	1
8		•• Wrench, 11/16 Inch	1
9		•• Wrench, 3/4 Inch	1
10		•• Wrench, 13/16 Inch	1
11		•• Wrench, 7/8 Inch	1
12		•• Wrench, 15/16 Inch	1
13		•• Wrench, 1 Inch	1
14		•• Wrench, 1-1/16 Inch	1
15		•• Wrench, 1-1/8 Inch	1
16		•• Wrench, 1-1/4 Inch	1
17		•• Wrap, Plastic	1
18	79036	• Wrench, 1-3/8 Inch	1
19	79028	• Wrench, 1-1/2 Inch	1
20	79038	• Screwdriver	1
21	79814	• Wrench, Strap (for Filter)	1
22	79325	• Wrench, Spanner	1
23	79031	• Wrench, Monkey	1
24	79032	• Wrench, Adjustable 24 Inch	1
25	77502	• Bag, Tool	1
26	79030	• Set, Metric Allen Key (2-8 mm)	1
27	79029	• Set, Standard Allen Key (3/16-3/8 Inch)	1
DASH (-) ITEM NOT ILLUSTRATED			

REVISION:



ACTUATOR BRAKES ASSEMBLY

C50HP
PARTS
GROUP 80
FIGURE 07
PAGE 01

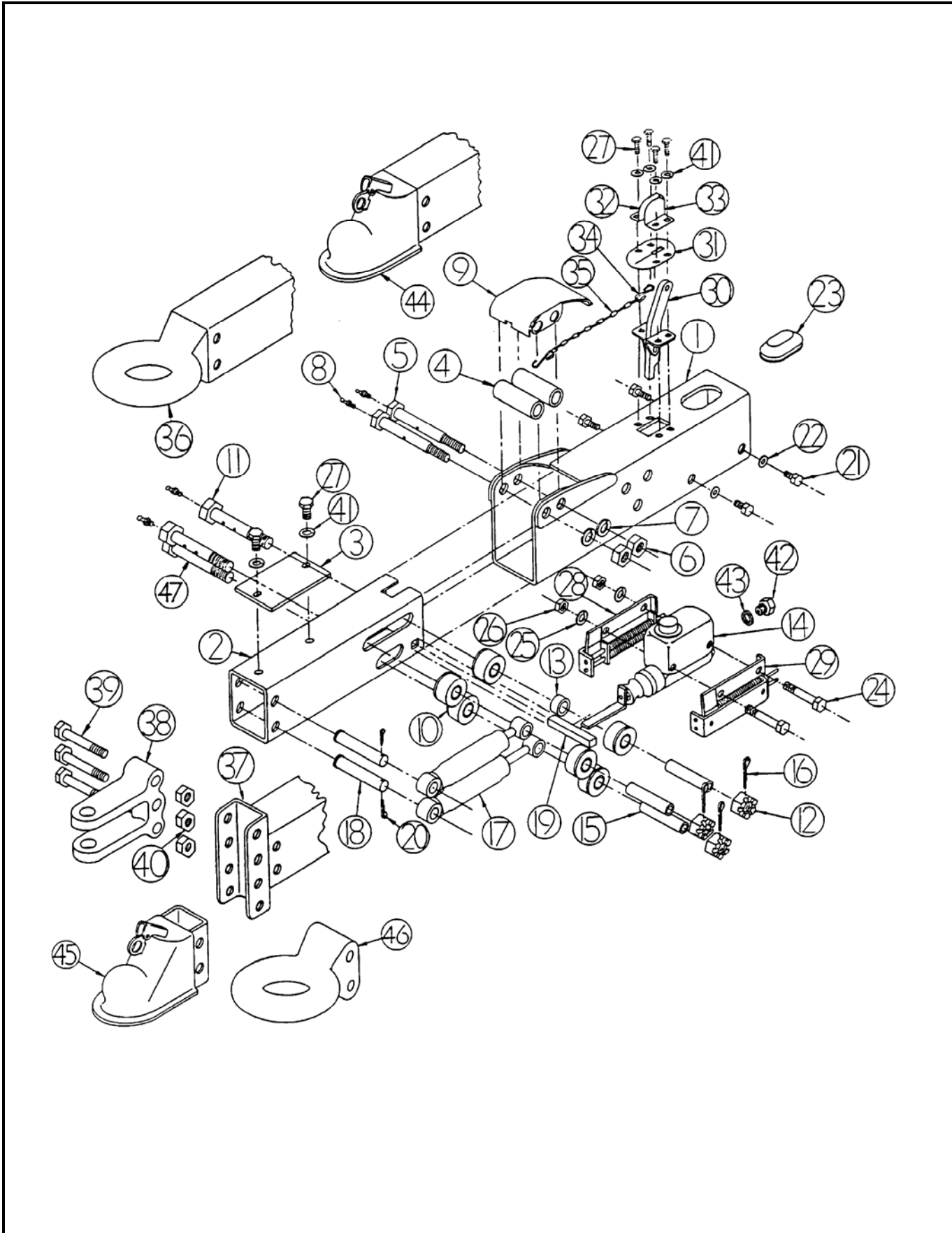

REVISION:



ACTUATOR BRAKES ASSEMBLY

C50HP
PARTS
 GROUP 80
 FIGURE 07
 PAGE 02

ITEM NO.	REED'S PARTS NO.	DESCRIPTION	QTY																																																																																																																																																																																																																								
A	87191	1 2 3 4 5 Assembly, Actuator Brakes (See Group 80, Figure 01 for NHA)	Ref																																																																																																																																																																																																																								
		<table border="1" style="width: 100%; border-collapse: collapse;"> <thead> <tr> <th style="width: 5%;">KEY NO.</th> <th style="width: 10%;">PART NO.</th> <th style="width: 45%;">DESCRIPTION</th> <th style="width: 5%;">KEY NO.</th> <th style="width: 10%;">PART NO.</th> <th style="width: 25%;">DESCRIPTION</th> </tr> </thead> <tbody> <tr> <td>1</td> <td>1055300</td> <td>Outer Case Assembly - Primer</td> <td>25</td> <td>1255200</td> <td>GR 5, Zinc STAR Lockwasher 3/8"</td> </tr> <tr> <td>1</td> <td>1734900</td> <td>Outer Case Assembly w/Mounting Channel - Primer</td> <td>26</td> <td>0797600</td> <td>Hex Nut 3/8 NC</td> </tr> <tr> <td></td> <td></td> <td></td> <td>27</td> <td>0794900</td> <td>HX HD Capscrew 5/16x5/8 NC, GR 5, Zinc</td> </tr> <tr> <td>1</td> <td>4488300</td> <td>Outer Case Assembly w/Mounting Channel - Plated</td> <td>28</td> <td>0838800</td> <td>RH Cylinder Bracket Assembly</td> </tr> <tr> <td>2</td> <td>1556300</td> <td>Inner Slide Assembly - No Coupler</td> <td>29</td> <td>0838900</td> <td>LH Cylinder Bracket Assembly</td> </tr> <tr> <td>2</td> <td>1735000</td> <td>Inner Slide Assembly w/2-5/16" Drop Coupler</td> <td>30</td> <td>1054100</td> <td>Breakaway Lever Assembly</td> </tr> <tr> <td></td> <td></td> <td></td> <td>31</td> <td>1055200</td> <td>Weather Seal</td> </tr> <tr> <td>2</td> <td>4490400</td> <td>Inner Slide Assembly w/2-5/16" Drop Coupler - Plated</td> <td>32</td> <td>1052700</td> <td>RH Breakaway Lock - Plated</td> </tr> <tr> <td></td> <td></td> <td></td> <td>33</td> <td>1052600</td> <td>LH Breakaway Lock - Plated</td> </tr> <tr> <td>3</td> <td>0828400</td> <td>Centering Rail</td> <td>34</td> <td>1055500</td> <td>S-Hook</td> </tr> <tr> <td>4</td> <td>1601900</td> <td>Front Roller - Plated</td> <td>35</td> <td>0776800</td> <td>Safety Chain</td> </tr> <tr> <td>5</td> <td>0828800</td> <td>Front Roller Bolt 5/8x5.25-1/2 NC</td> <td>36</td> <td>1297600</td> <td>Inner Slide Assembly w/ 3" Lunette Eye</td> </tr> <tr> <td>6</td> <td>0798500</td> <td>Hex Nut 1/2 NC</td> <td>37</td> <td>1058200</td> <td>Inner Slide Assembly w/Leveler Channel</td> </tr> <tr> <td>7</td> <td>0793700</td> <td>Lockwasher 1/2" STD</td> <td></td> <td></td> <td></td> </tr> <tr> <td>8</td> <td>0144901</td> <td>Zerk 35/64</td> <td>38</td> <td>1807800</td> <td>Clevis Hitch, For 1" Pin</td> </tr> <tr> <td>9</td> <td>0828900</td> <td>Front Roller Cover</td> <td>39</td> <td>0909300</td> <td>HHCS 5/8x4.5 NC, GR 5, Zinc</td> </tr> <tr> <td>9</td> <td>0828925</td> <td>Front Roller Cover - Plated</td> <td></td> <td></td> <td></td> </tr> <tr> <td>10</td> <td>0829100</td> <td>Rear Roller</td> <td>40</td> <td>1040500</td> <td>Locknut 5/8 NC</td> </tr> <tr> <td>11</td> <td>0829400</td> <td>Roller Bolt 5/8x5 NF, GR 5</td> <td>41</td> <td>0793800</td> <td>Lockwasher 5/16" STD</td> </tr> <tr> <td>12</td> <td>0797100</td> <td>Slotted Hex Nut 5/8 NC</td> <td>42</td> <td>1209900</td> <td>Connector Drum Brake</td> </tr> <tr> <td>13</td> <td>0332800</td> <td>Spacer</td> <td>42</td> <td>4750200, 4750300</td> <td>Connector Disc Brake</td> </tr> <tr> <td>14</td> <td>1250300</td> <td>Filler Cap (Included in 23744)</td> <td>43</td> <td>0774500</td> <td>Gasket</td> </tr> <tr> <td>14</td> <td>2374400</td> <td>Master Cylinder Assembly, 1-1/4" Bore (drum)</td> <td>44</td> <td>1278800</td> <td>Inner Slide Assembly w/2-5/16" Coupler - Primer</td> </tr> <tr> <td>14</td> <td>4747100</td> <td>Master Cylinder Assy. (disc)</td> <td>44</td> <td>4488400</td> <td>Inner Slide Assembly w/2-5/16" Coupler - Plated</td> </tr> <tr> <td>14</td> <td></td> <td>Push Rod Bracket Assembly (Included in 23744)</td> <td>45</td> <td>1882000</td> <td>Adjustable Ball Coupler - 2-5/16"</td> </tr> <tr> <td>15</td> <td>0829700</td> <td>Spacer</td> <td>46</td> <td>1613700</td> <td>Lunette Eye - 3" Adjustable</td> </tr> <tr> <td>16</td> <td>0799700</td> <td>Cotter Pin-1/8x1.00</td> <td>47</td> <td>0829500</td> <td>HX HD Screw 5/8x5 NF, GR 5</td> </tr> <tr> <td>17</td> <td>0778400</td> <td>Damper</td> <td></td> <td></td> <td></td> </tr> <tr> <td>18</td> <td>0829800</td> <td>Damper Bar</td> <td></td> <td>1018700</td> <td>1-1/4" Master Cylinder Repair Kit Drum Brake</td> </tr> <tr> <td>19</td> <td>0830100</td> <td>Pushrod Block</td> <td></td> <td>1848700</td> <td>2-5/16" Ball Coupler Repair Kit</td> </tr> <tr> <td>20</td> <td>0799700</td> <td>Cotter Pin-1/8x3/4</td> <td></td> <td></td> <td></td> </tr> <tr> <td>21</td> <td>0794800</td> <td>HX HD Capscrew 5/16x1/2 NC, GR 5, Zinc</td> <td></td> <td>2402900</td> <td>Model 20 I&I Manual</td> </tr> <tr> <td>22</td> <td>1248900</td> <td>Star Lockwasher 5/16"</td> <td></td> <td>4823800</td> <td>Master Cylinder Repair Kit Disc Brake</td> </tr> <tr> <td>23</td> <td>1507000</td> <td>Cylinder Cover</td> <td></td> <td></td> <td></td> </tr> <tr> <td>24</td> <td>0827100</td> <td>HX HD Capscrew 3/8x3 NC,</td> <td></td> <td></td> <td></td> </tr> </tbody> </table>	KEY NO.	PART NO.	DESCRIPTION	KEY NO.	PART NO.	DESCRIPTION	1	1055300	Outer Case Assembly - Primer	25	1255200	GR 5, Zinc STAR Lockwasher 3/8"	1	1734900	Outer Case Assembly w/Mounting Channel - Primer	26	0797600	Hex Nut 3/8 NC				27	0794900	HX HD Capscrew 5/16x5/8 NC, GR 5, Zinc	1	4488300	Outer Case Assembly w/Mounting Channel - Plated	28	0838800	RH Cylinder Bracket Assembly	2	1556300	Inner Slide Assembly - No Coupler	29	0838900	LH Cylinder Bracket Assembly	2	1735000	Inner Slide Assembly w/2-5/16" Drop Coupler	30	1054100	Breakaway Lever Assembly				31	1055200	Weather Seal	2	4490400	Inner Slide Assembly w/2-5/16" Drop Coupler - Plated	32	1052700	RH Breakaway Lock - Plated				33	1052600	LH Breakaway Lock - Plated	3	0828400	Centering Rail	34	1055500	S-Hook	4	1601900	Front Roller - Plated	35	0776800	Safety Chain	5	0828800	Front Roller Bolt 5/8x5.25-1/2 NC	36	1297600	Inner Slide Assembly w/ 3" Lunette Eye	6	0798500	Hex Nut 1/2 NC	37	1058200	Inner Slide Assembly w/Leveler Channel	7	0793700	Lockwasher 1/2" STD				8	0144901	Zerk 35/64	38	1807800	Clevis Hitch, For 1" Pin	9	0828900	Front Roller Cover	39	0909300	HHCS 5/8x4.5 NC, GR 5, Zinc	9	0828925	Front Roller Cover - Plated				10	0829100	Rear Roller	40	1040500	Locknut 5/8 NC	11	0829400	Roller Bolt 5/8x5 NF, GR 5	41	0793800	Lockwasher 5/16" STD	12	0797100	Slotted Hex Nut 5/8 NC	42	1209900	Connector Drum Brake	13	0332800	Spacer	42	4750200, 4750300	Connector Disc Brake	14	1250300	Filler Cap (Included in 23744)	43	0774500	Gasket	14	2374400	Master Cylinder Assembly, 1-1/4" Bore (drum)	44	1278800	Inner Slide Assembly w/2-5/16" Coupler - Primer	14	4747100	Master Cylinder Assy. (disc)	44	4488400	Inner Slide Assembly w/2-5/16" Coupler - Plated	14		Push Rod Bracket Assembly (Included in 23744)	45	1882000	Adjustable Ball Coupler - 2-5/16"	15	0829700	Spacer	46	1613700	Lunette Eye - 3" Adjustable	16	0799700	Cotter Pin-1/8x1.00	47	0829500	HX HD Screw 5/8x5 NF, GR 5	17	0778400	Damper				18	0829800	Damper Bar		1018700	1-1/4" Master Cylinder Repair Kit Drum Brake	19	0830100	Pushrod Block		1848700	2-5/16" Ball Coupler Repair Kit	20	0799700	Cotter Pin-1/8x3/4				21	0794800	HX HD Capscrew 5/16x1/2 NC, GR 5, Zinc		2402900	Model 20 I&I Manual	22	1248900	Star Lockwasher 5/16"		4823800	Master Cylinder Repair Kit Disc Brake	23	1507000	Cylinder Cover				24	0827100	HX HD Capscrew 3/8x3 NC,				
KEY NO.	PART NO.	DESCRIPTION	KEY NO.	PART NO.	DESCRIPTION																																																																																																																																																																																																																						
1	1055300	Outer Case Assembly - Primer	25	1255200	GR 5, Zinc STAR Lockwasher 3/8"																																																																																																																																																																																																																						
1	1734900	Outer Case Assembly w/Mounting Channel - Primer	26	0797600	Hex Nut 3/8 NC																																																																																																																																																																																																																						
			27	0794900	HX HD Capscrew 5/16x5/8 NC, GR 5, Zinc																																																																																																																																																																																																																						
1	4488300	Outer Case Assembly w/Mounting Channel - Plated	28	0838800	RH Cylinder Bracket Assembly																																																																																																																																																																																																																						
2	1556300	Inner Slide Assembly - No Coupler	29	0838900	LH Cylinder Bracket Assembly																																																																																																																																																																																																																						
2	1735000	Inner Slide Assembly w/2-5/16" Drop Coupler	30	1054100	Breakaway Lever Assembly																																																																																																																																																																																																																						
			31	1055200	Weather Seal																																																																																																																																																																																																																						
2	4490400	Inner Slide Assembly w/2-5/16" Drop Coupler - Plated	32	1052700	RH Breakaway Lock - Plated																																																																																																																																																																																																																						
			33	1052600	LH Breakaway Lock - Plated																																																																																																																																																																																																																						
3	0828400	Centering Rail	34	1055500	S-Hook																																																																																																																																																																																																																						
4	1601900	Front Roller - Plated	35	0776800	Safety Chain																																																																																																																																																																																																																						
5	0828800	Front Roller Bolt 5/8x5.25-1/2 NC	36	1297600	Inner Slide Assembly w/ 3" Lunette Eye																																																																																																																																																																																																																						
6	0798500	Hex Nut 1/2 NC	37	1058200	Inner Slide Assembly w/Leveler Channel																																																																																																																																																																																																																						
7	0793700	Lockwasher 1/2" STD																																																																																																																																																																																																																									
8	0144901	Zerk 35/64	38	1807800	Clevis Hitch, For 1" Pin																																																																																																																																																																																																																						
9	0828900	Front Roller Cover	39	0909300	HHCS 5/8x4.5 NC, GR 5, Zinc																																																																																																																																																																																																																						
9	0828925	Front Roller Cover - Plated																																																																																																																																																																																																																									
10	0829100	Rear Roller	40	1040500	Locknut 5/8 NC																																																																																																																																																																																																																						
11	0829400	Roller Bolt 5/8x5 NF, GR 5	41	0793800	Lockwasher 5/16" STD																																																																																																																																																																																																																						
12	0797100	Slotted Hex Nut 5/8 NC	42	1209900	Connector Drum Brake																																																																																																																																																																																																																						
13	0332800	Spacer	42	4750200, 4750300	Connector Disc Brake																																																																																																																																																																																																																						
14	1250300	Filler Cap (Included in 23744)	43	0774500	Gasket																																																																																																																																																																																																																						
14	2374400	Master Cylinder Assembly, 1-1/4" Bore (drum)	44	1278800	Inner Slide Assembly w/2-5/16" Coupler - Primer																																																																																																																																																																																																																						
14	4747100	Master Cylinder Assy. (disc)	44	4488400	Inner Slide Assembly w/2-5/16" Coupler - Plated																																																																																																																																																																																																																						
14		Push Rod Bracket Assembly (Included in 23744)	45	1882000	Adjustable Ball Coupler - 2-5/16"																																																																																																																																																																																																																						
15	0829700	Spacer	46	1613700	Lunette Eye - 3" Adjustable																																																																																																																																																																																																																						
16	0799700	Cotter Pin-1/8x1.00	47	0829500	HX HD Screw 5/8x5 NF, GR 5																																																																																																																																																																																																																						
17	0778400	Damper																																																																																																																																																																																																																									
18	0829800	Damper Bar		1018700	1-1/4" Master Cylinder Repair Kit Drum Brake																																																																																																																																																																																																																						
19	0830100	Pushrod Block		1848700	2-5/16" Ball Coupler Repair Kit																																																																																																																																																																																																																						
20	0799700	Cotter Pin-1/8x3/4																																																																																																																																																																																																																									
21	0794800	HX HD Capscrew 5/16x1/2 NC, GR 5, Zinc		2402900	Model 20 I&I Manual																																																																																																																																																																																																																						
22	1248900	Star Lockwasher 5/16"		4823800	Master Cylinder Repair Kit Disc Brake																																																																																																																																																																																																																						
23	1507000	Cylinder Cover																																																																																																																																																																																																																									
24	0827100	HX HD Capscrew 3/8x3 NC,																																																																																																																																																																																																																									

REVISION:



WASH PUMP ASSEMBLY

C50HP
PARTS
GROUP 80
FIGURE 08
PAGE 01

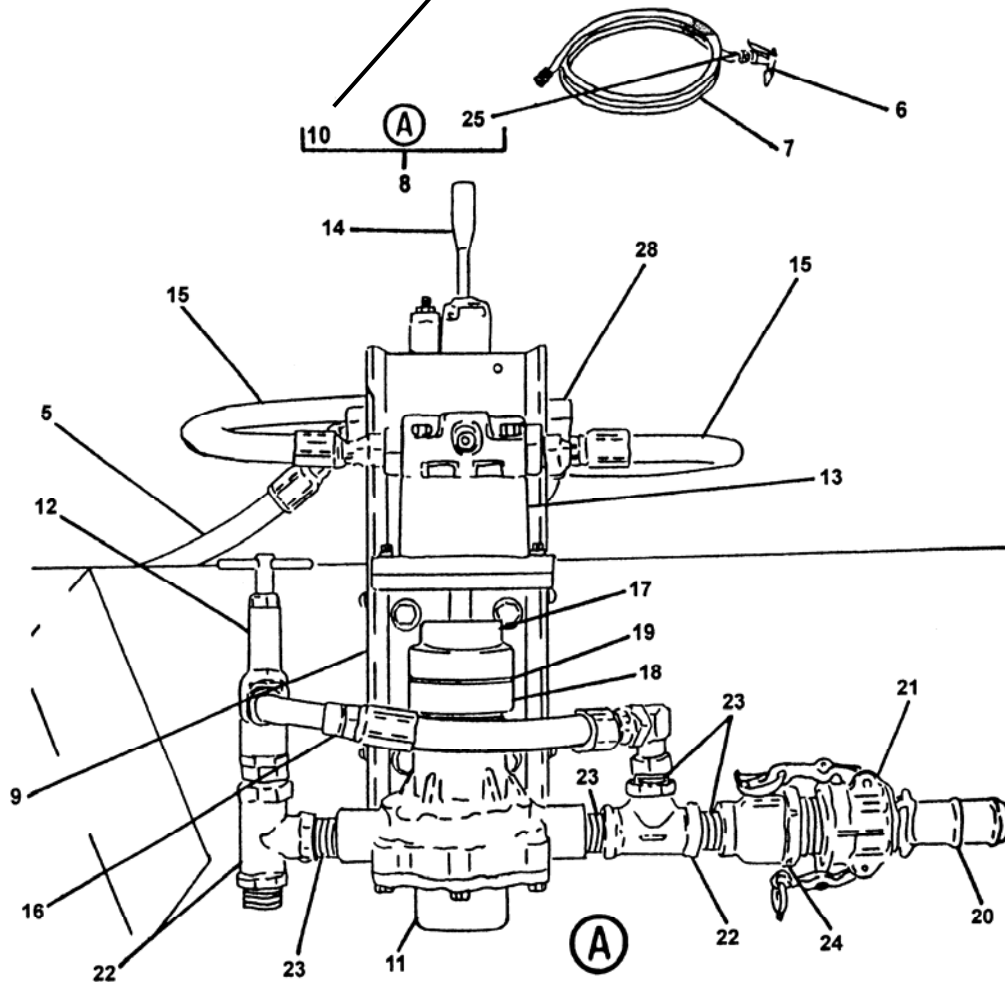

REVISION:



WASH PUMP ASSEMBLY

C50HP
PARTS
GROUP 80
FIGURE 08
PAGE 02

ITEM NO.	REED'S PARTS NO.	DESCRIPTION	QTY
		1 2 3 4 5	
-1	86399	Wash Pump Kit, C-Series (PN 86200 Wash Pump Assy-Only)	Ref
2	86384	• Sleeve, Power Beyond	1
3	86692	• Spacer, Agitator Valve	1
4	85657-021	• Hose-8M2T-10FJX-10FJX45-12.25	1
5	85657-020	• Hose-8M2T-10FJX-10FJX45-64.00	1
6	800098	• Nozzle, Garden Hose	1
7	86267	• Hose, Garden 20 FT	1
8	86200	• Wash Pump Assy-Only	1
9	86196	• Wash Pump Base Weldment	1
10	86199	• Cover, Wash Pump	1
11	78157	• Washpump-Hydro	1
12	78128	• Valve, Relief	1
13	78152	• Motor-Hyd Wash Pump	1
14	86397	• Valve-Manual-1 Spool-3 Way	1
15	85658-002	• Hose-6M2T-6FJX-6FJX-17.00	2
16	85657-022	• Hose-8M2T-10FJX-10FJX90S-11.25	1
17	78153	• Coupling, Wash Motor	1
18	78154	• Coupling, Wash Pump	1
19	78155	• Spider	1
20	10948	• Coupling-Cam/Groove 1.25" Female x MPT	1
21	10947	• Coupling-Cam/Groove 1.25" Male x MPT	1
22	10228	• Tee-3/4"	2
23	40047	• Nipple-Close Pipe-3/4"	4
24	86398	• Bell Reducer-3/4" x 1 1/4"	1
25	800371	• Fitting-Garden Hose	1
26	801902-020	• Tube Clamp-3/8" - Single	1
27	86721	• Wash Pump Installation C-Series (Drawing)	REF
28	85657-012	• Hose-8M2T-10FJX-10FJX-64.00	1
		DASH (-) ITEM NOT ILLUSTRATED	

REVISION:



WASH WATER PUMP ASSEMBLY

C50HP
PARTS
GROUP 80
FIGURE 09
PAGE 01

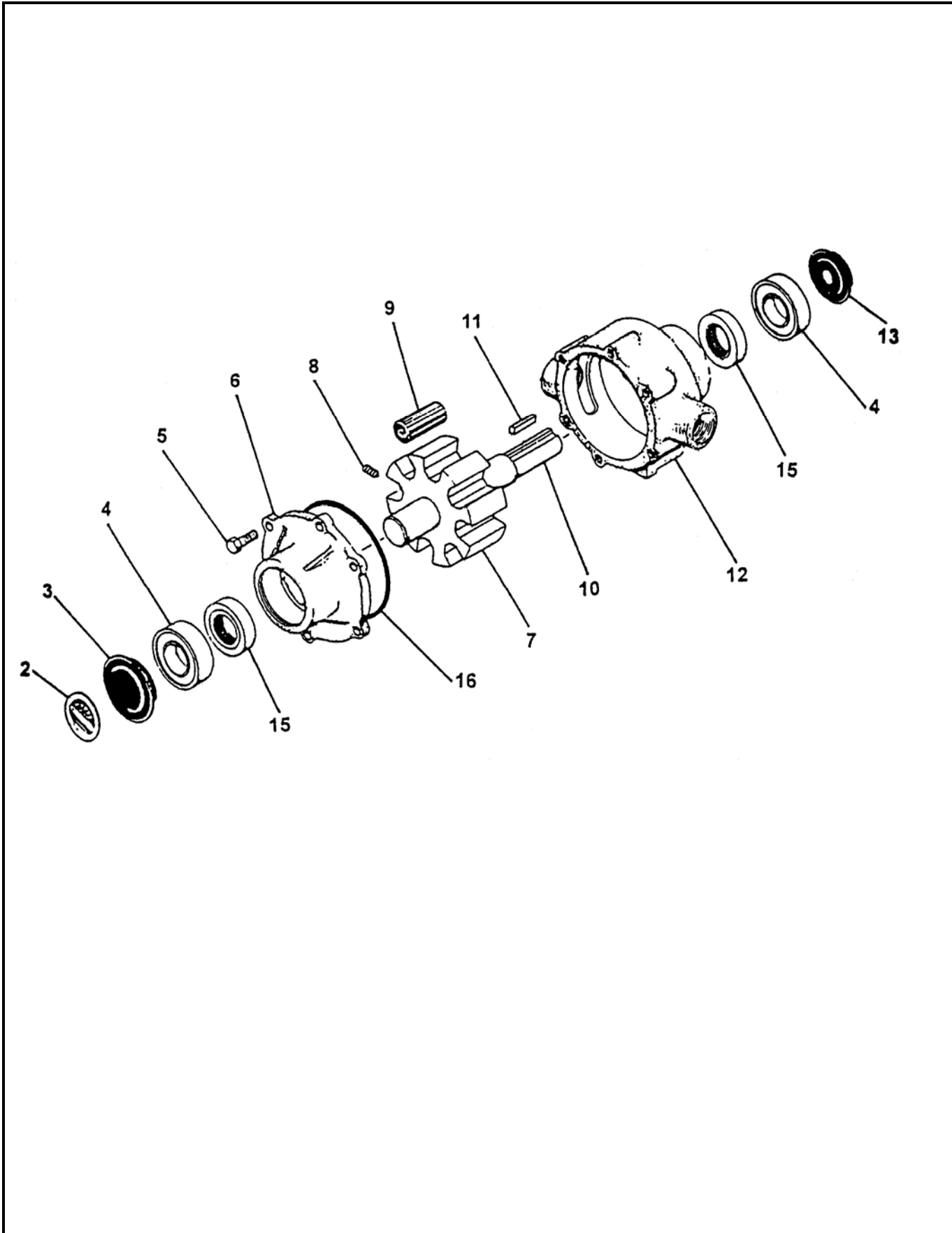

REVISION:



WASH WATER PUMP ASSEMBLY

C50HP
PARTS
GROUP 80
FIGURE 09
PAGE 02

ITEM NO.	REED'S PARTS NO.	DESCRIPTION	QTY
		1 2 3 4 5	
-1	78157	Assembly, Wash Water Pump (See Group 80, Figure 08 for NHA)	Ref
2		• Plate, Name	1
3		• Cover, Bearing Rear	1
4		• Bearing, Sealed Bowl	2
5		• Endplate, (Ni-Resist) with Seal	1
6		• Bolt, Hex (attaching parts)	6
7		• Rotor, (Ni-Resist) with Shaft	1
8		• Screw, Set (attaching parts)	1
9		• Roller, Teflon	1
10		• Shaft	1
11		• Key	1
12		• Body, (Ni-Resist) with Seal	1
13		• Cover, Bearing Shaft	1
-14	72329	• Kit, Seal	1
15		•• Seal, Buna	2
16		•• Gasket, End Plate O-Ring	1
		DASH (-) ITEM NOT ILLUSTRATED	

REVISION:



WASH PUMP MOTOR ASSEMBLY

C50HP
PARTS
GROUP 80
FIGURE 10
PAGE 01

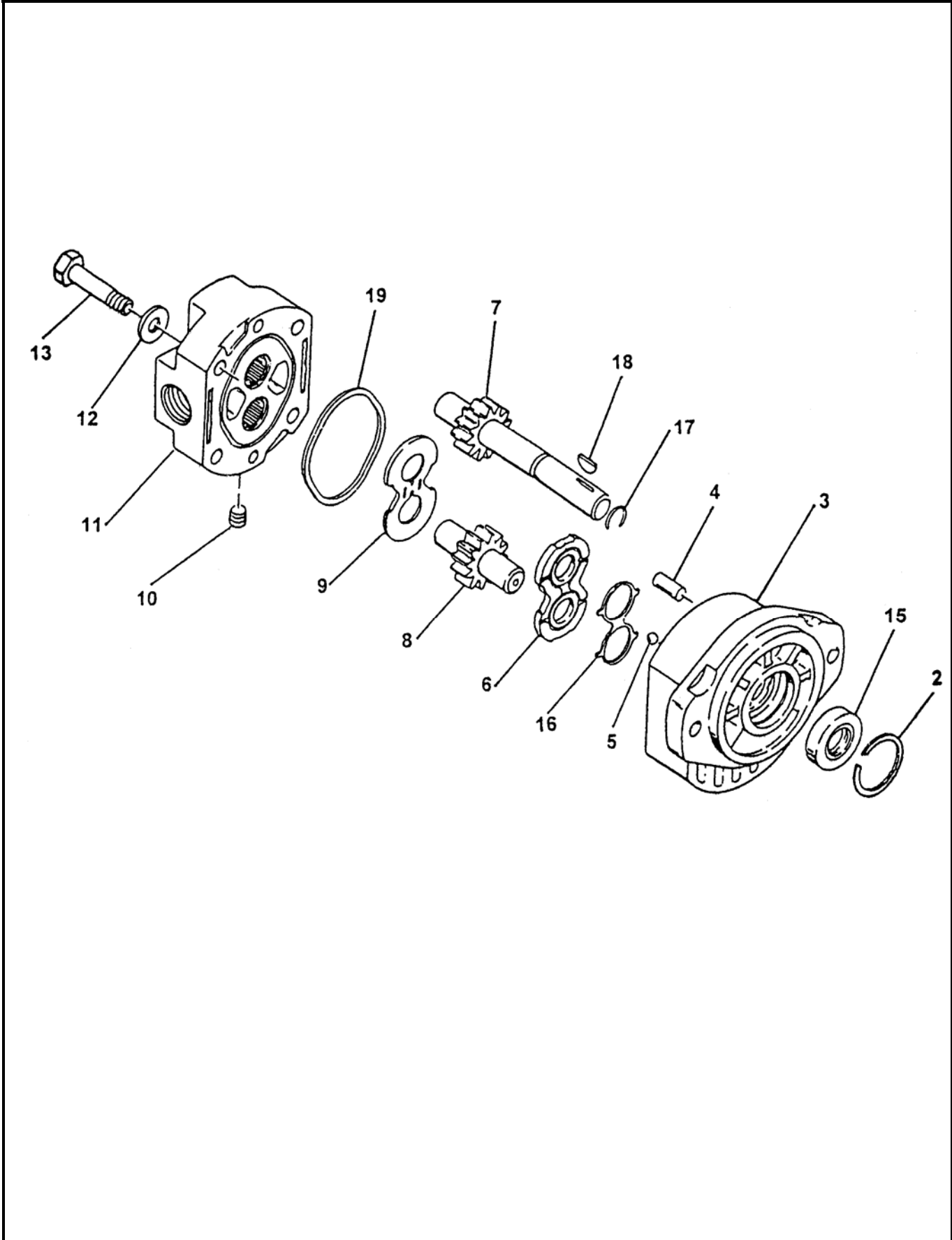

REVISION:



WASH PUMP MOTOR ASSEMBLY

C50HP
PARTS
GROUP 80
FIGURE 10
PAGE 02

ITEM NO.	REED'S PARTS NO.	DESCRIPTION	QTY
		1 2 3 4 5	
-1	78152	Assembly, Wash Pump Motor (See Group 80, Figure 09 for NHA)	Ref
2		• Retainer	1
3		• Assembly, Body	1
4		• Pin, Dowel	2
5		• Bearing, Ball	2
6		• Plate, Wear	1
7		• Gear, Driven Wear	1
8		• Gear, Driven	1
9		• Plate, Thrust	1
10		• Plug, Pipe	4
11		• Assembly, Cover	1
12		• Washer (attaching parts)	4
13		• Screw, Hex (attaching parts)	4
14		• Kit, Seal	1
15		• • Brush	1
16		• • Cap, Brush	1
17		• • Gasket	1
18		• • Cover, Brush	1
		DASH (-) ITEM NOT ILLUSTRATED	

REVISION:



ACCUMULATOR CHARGE KIT

C50HP
PARTS
GROUP 80
FIGURE 11
PAGE 01

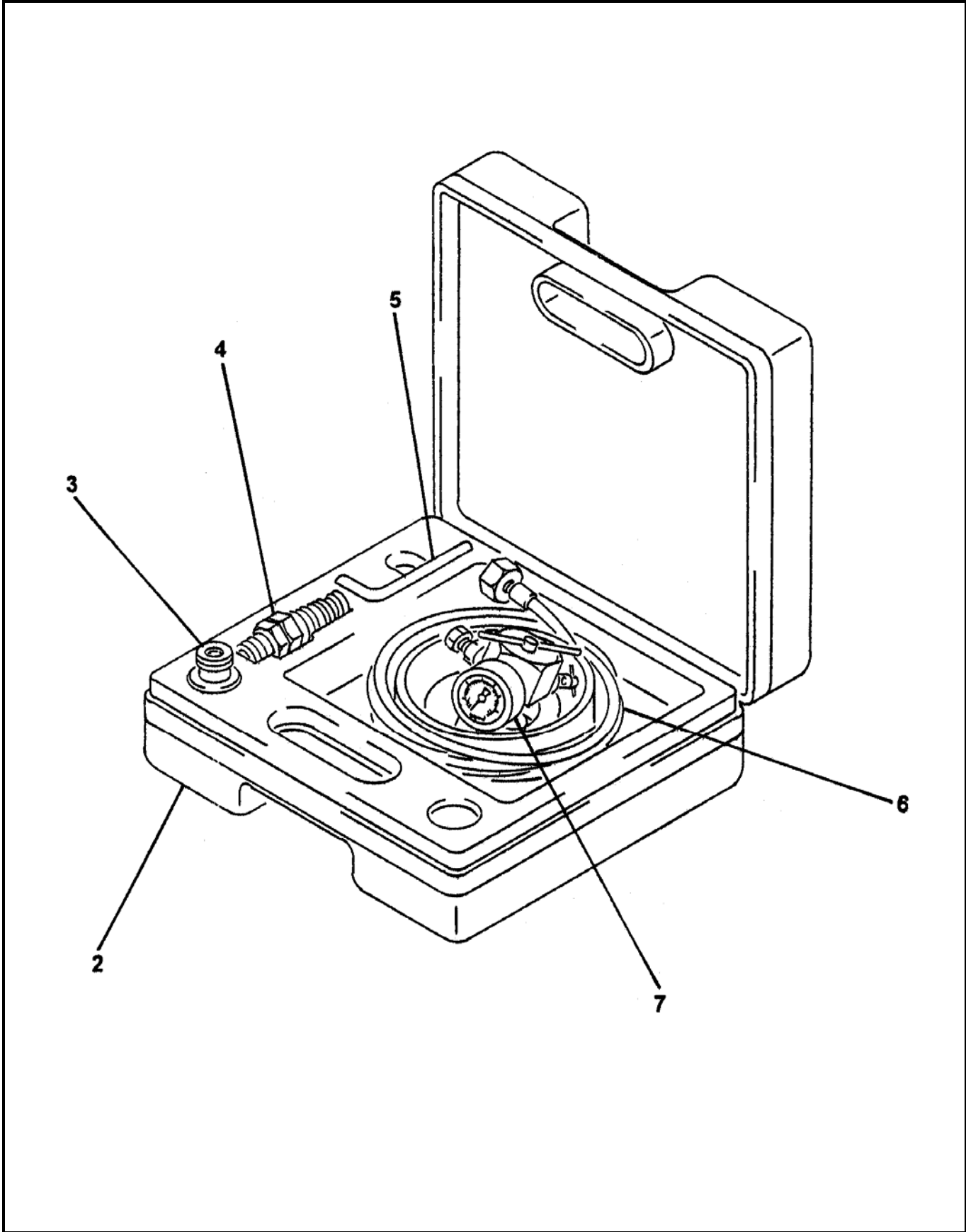

REVISION:



ACCUMULATOR CHARGE KIT

C50HP
PARTS
GROUP 80
FIGURE 11
PAGE 02

ITEM NO.	REED'S PARTS NO.	DESCRIPTION	QTY
-1	71460	1 2 3 4 5 Kit, Accumulator Charge (See Group 80, Figure 01 for NHA)	Ref
2		• Case, Charge Kit	1
3		• Adapter, FPK / SB	1
4		• Adapter, G4	1
5		• Wrench, Allen	1
6		• Hose, Charging	1
7		• Unit, FPK Charging and Gagging	1
		DASH (-) ITEM NOT ILLUSTRATED	

REVISION:



NON-OPERATOR SIDE HYDRAULIC BRAKE ASSEMBLY

C50HP
PARTS
GROUP 80
FIGURE 12
PAGE 01

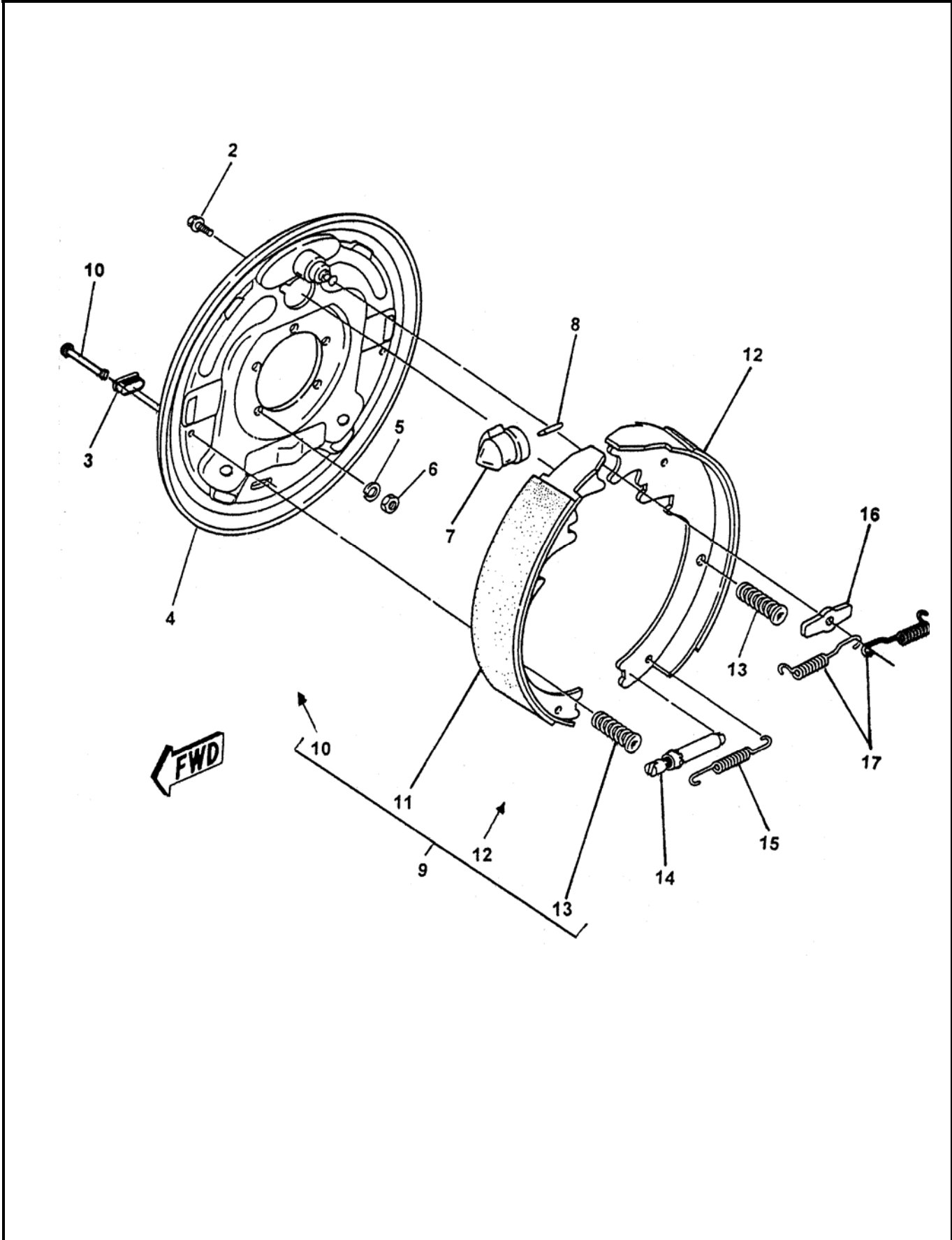

REVISION:



NON-OPERATOR SIDE HYDRAULIC BRAKE ASSEMBLY

C50HP
PARTS
GROUP 80
FIGURE 12
PAGE 02

ITEM NO.	REED'S PARTS NO.	DESCRIPTION	QTY
		1 2 3 4 5	
-1	80-12	Assembly, Non-Operator Side Hydraulic Brake (See Group 80, Figure 01 for NHA)	Ref
2		• Screw, with Washer	1
3		• Plug	2
4		• Plate, Backing	1
5		• Washer, Lock (attaching parts)	5
6		• Nut, Brake Mounting (attaching parts)	5
7		• Cylinder, Non-Operator Side Brake	1
8		• Rod, Push	1
9		• Kit, Non-Operator Side Shoe and Lining	1
10		• • Pin, Shoe Hold Down	2
11		• • Primary, Non-Operator Side	1
12		• • Secondary, Non-Operator Side	1
13		• • Pin, Shoe Hold Down	2
14		• Assembly, Adjuster	1
15		• Spring, Adjusting Screw	1
16		• Washer, Anchor Post	1
17		• Spring, Retractor	2
		DASH (-) ITEM NOT ILLUSTRATED	

REVISION:



OPERATOR SIDE HYDRAULIC BRAKE ASSEMBLY

C50HP
PARTS
GROUP 80
FIGURE 13
PAGE 01

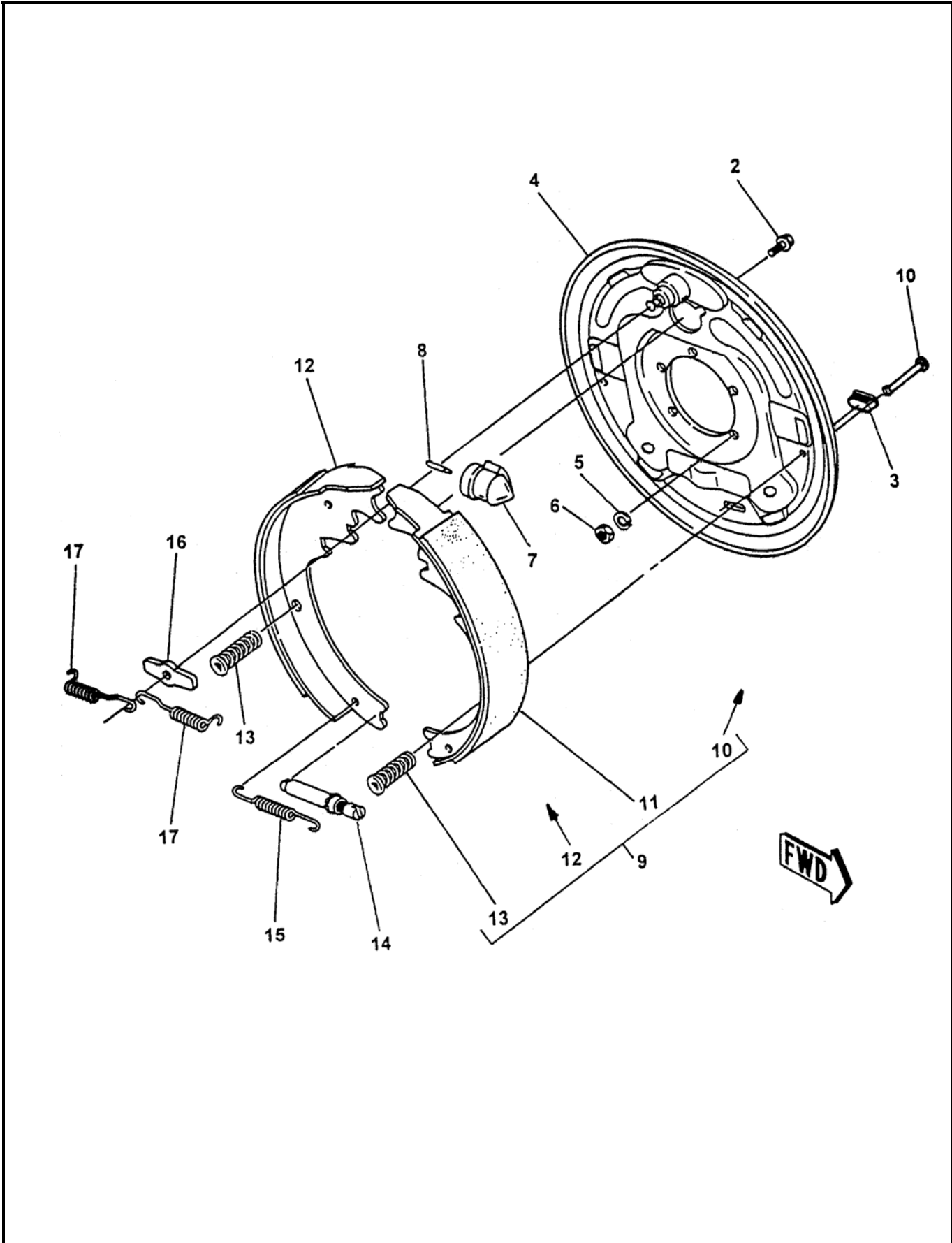

REVISION:



**OPERATOR SIDE
HYDRAULIC BRAKE ASSEMBLY**

**C50HP
PARTS
GROUP 80
FIGURE 13
PAGE 02**

ITEM NO.	REED'S PARTS NO.	DESCRIPTION	QTY
		1 2 3 4 5	
-1	80-13	Assembly, Operator Side Hydraulic Brake (See Group 80, Figure 01 for NHA)	Ref
2		• Screw, with Washer	1
3		• Plug	2
4		• Plate, Backing	1
5		• Washer, Lock (attaching parts)	5
6		• Nut, Brake Mounting (attaching parts)	5
7		• Cylinder, Operator Side Brake	1
8		• Rod, Push	1
9		• Kit, Operator Side Shoe and Lining	1
10		•• Pin, Shoe Hold Down	2
11		•• Primary, Operator Side	1
12		•• Secondary, Operator Side	1
13		•• Pin, Shoe Hold Down	2
14		• Assembly, Adjuster	1
15		• Spring, Adjusting Screw	1
16		• Washer, Anchor Post	1
17		• Spring, Retractor	2
		DASH (-) ITEM NOT ILLUSTRATED	

REVISION:



1 SPOOL VALVE ASSEMBLY

C50HP
PARTS
GROUP 80
FIGURE 14
PAGE 01

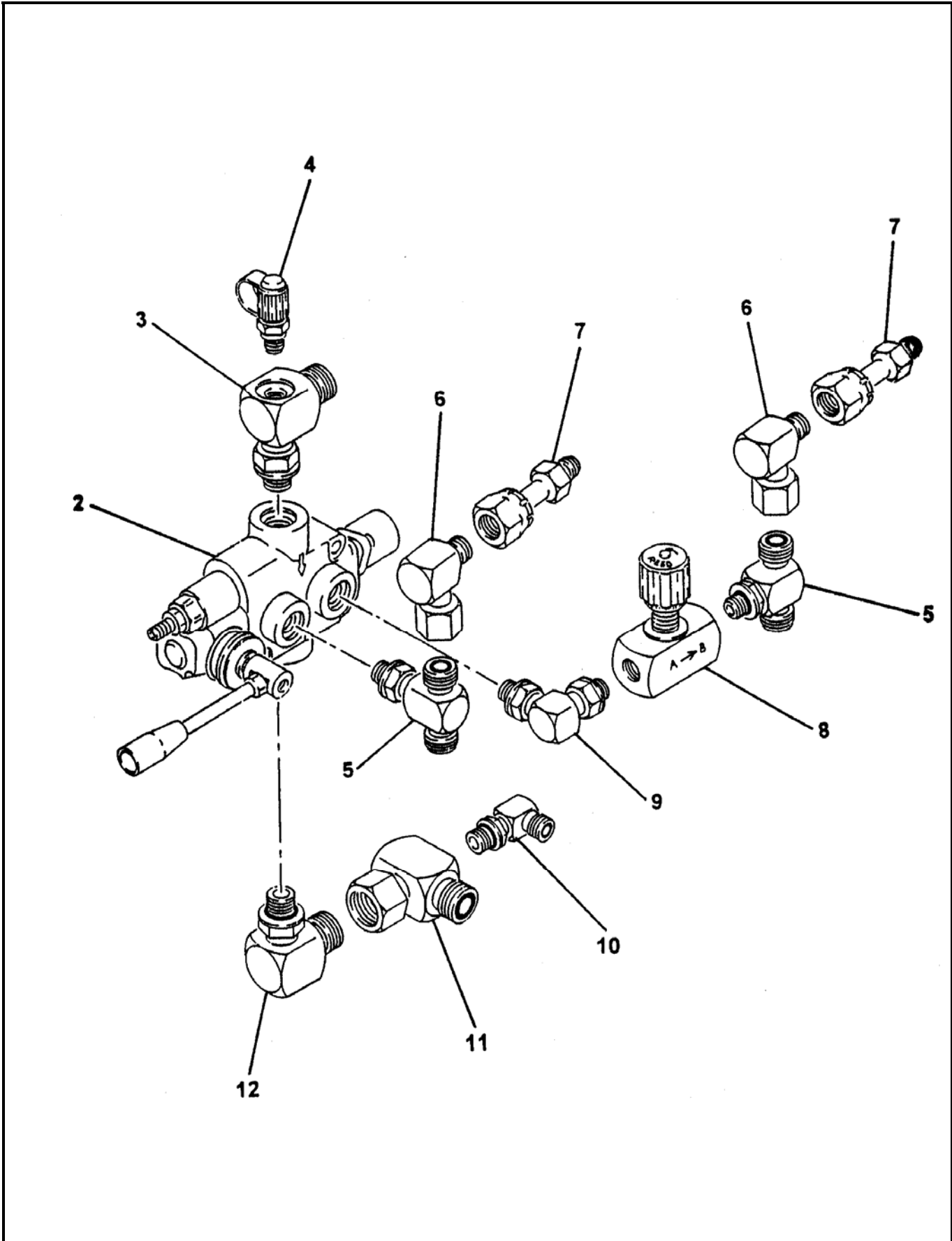

REVISION:



1 SPOOL VALVE ASSEMBLY

C50HP
PARTS
GROUP 80
FIGURE 14
PAGE 02

ITEM NO.	REED'S PARTS NO.	DESCRIPTION	QTY
-1	80-15	1 2 3 4 5 Assembly, 1 Spool Valve (See Group 80, Figure 01 for NHA)	Ref
2	74584	• Sub-Assembly, 1 Spool Valve (See Group 80, Figure 15 for DET)	1
3		• Tee, Special Drill	1
4	78593	• Fitting, Mini Check (Port)	1
5		• Tee	2
6		• Fitting, 90	2
7		• Fitting, Connector	2
8		• Controller, Check	1
9		• Fitting, 90	1
10		• Fitting, 90	1
11		• Tee, Special Drill	1
12		• Fitting, 90	1
		DASH (-) ITEM NOT ILLUSTRATED	

REVISION:

1 SPOOL VALVE SUB-ASSEMBLY

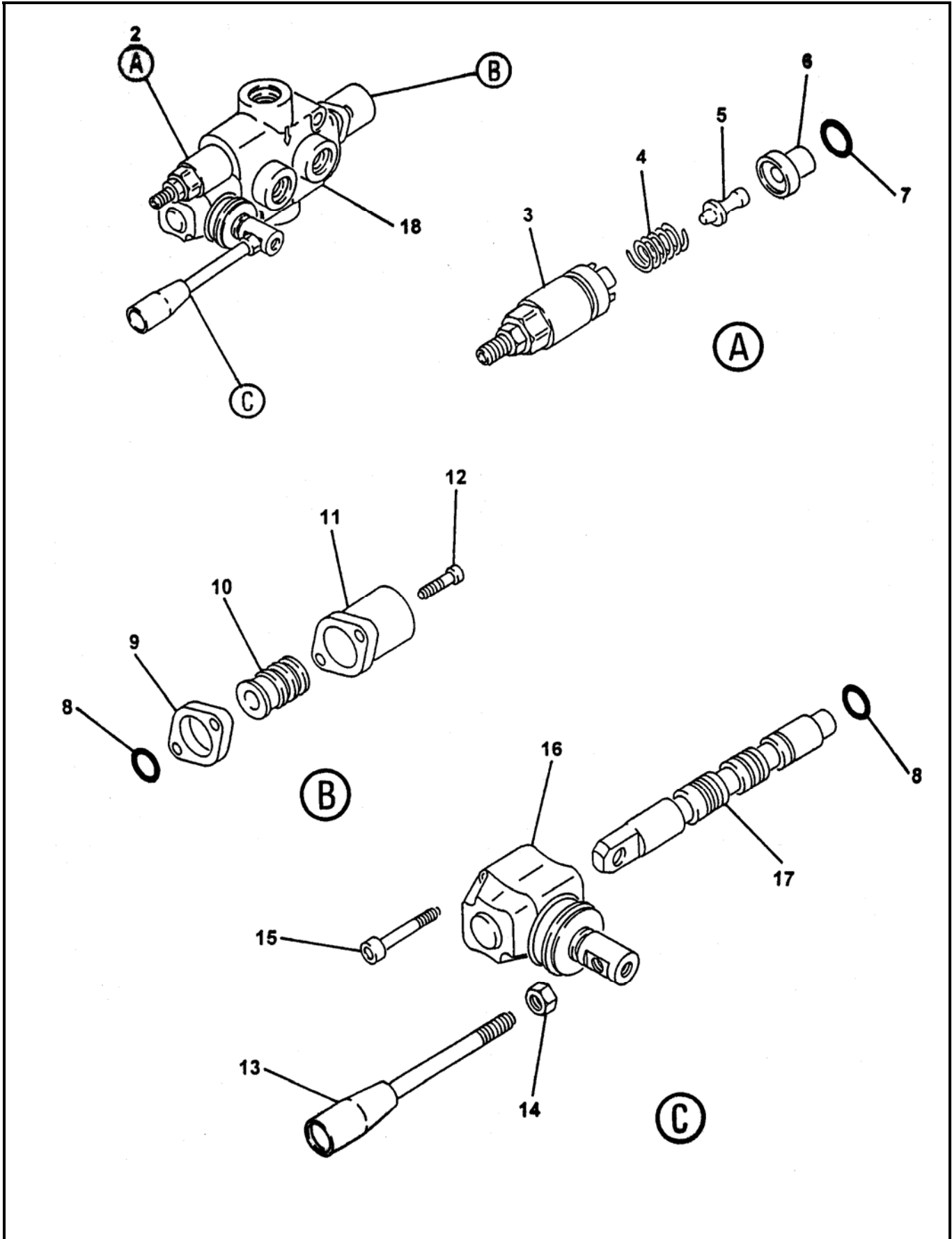



1 SPOOL VALVE SUB-ASSEMBLY

C50HP
PARTS
GROUP 80
FIGURE 15
PAGE 02

ITEM NO.	REED'S PARTS NO.	DESCRIPTION					QTY
		1	2	3	4	5	
-1	74584	Sub-Assembly, 1 Spool Valve (See Group 80, Figure 14 for NHA)					Ref
2		• Body, Valve					1
3		• Kit, Screw					1
4		• Spring					1
5		• Pin, Screw Kit					1
6		• Ring					1
7		• O-Ring					1
8		• O-Ring					2
9		• Spacer					1
10		• Kit, Spool Control					1
11		• Cap, Spool					1
12		• Screw, SOC (attaching Parts)					2
13		• Handle, Remixer Valve					1
14		• Nut (attaching parts)					1
15		• Screw, SOC					2
16		• Lever, L					1
17		• Spool					1
		DASH (-) ITEM NOT ILLUSTRATED					



2 SPOOL VALVE ASSEMBLY

C50HP
PARTS
GROUP 80
FIGURE 16
PAGE 01

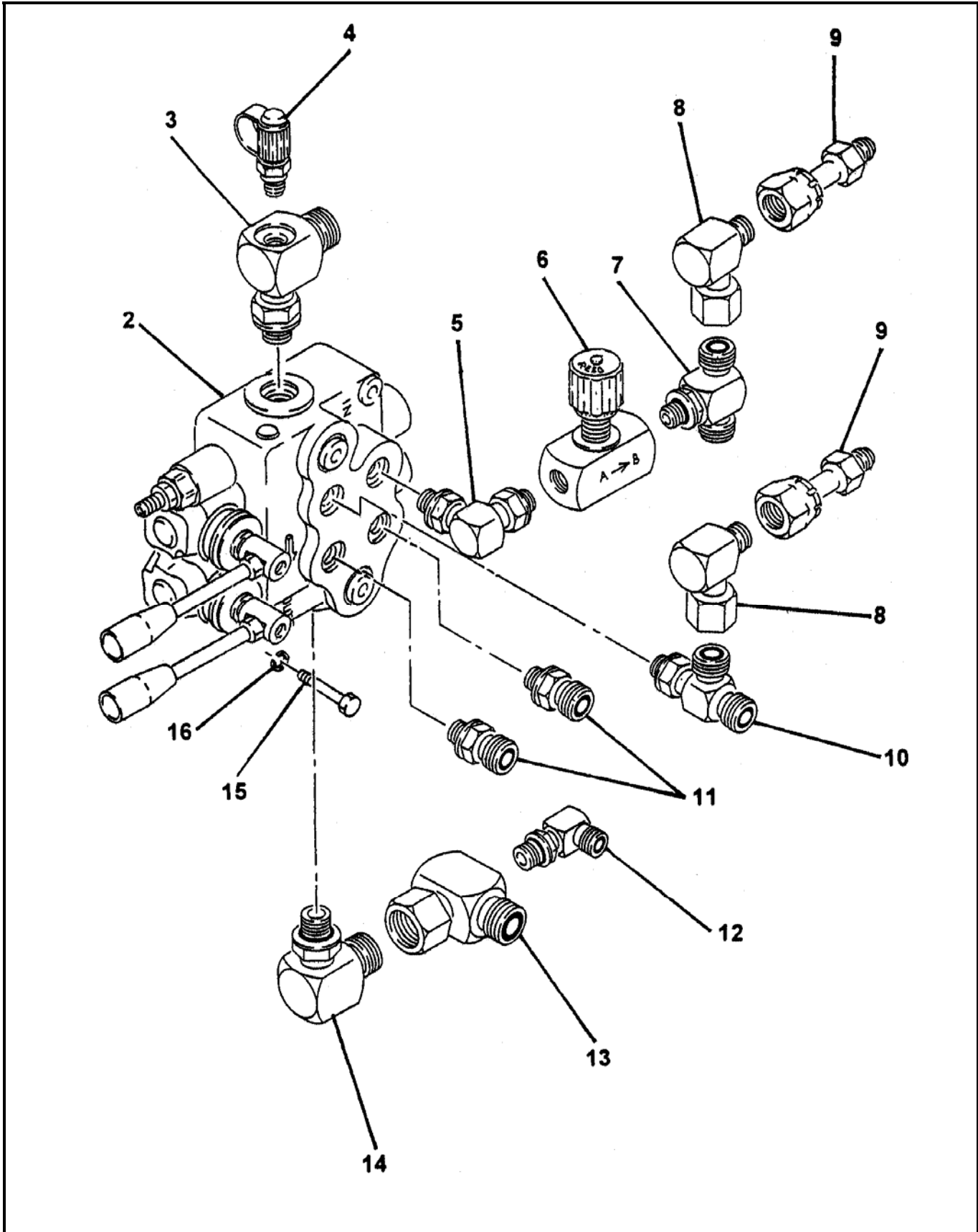



2 SPOOL VALVE ASSEMBLY

C50HP
PARTS
GROUP 80
FIGURE 16
PAGE 02

ITEM NO.	REED'S PARTS NO.	DESCRIPTION					QTY
		1	2	3	4	5	
-1	80-17	Assembly, 2 Spool Valve (See Group 80, Figure 01 for NHA)					Ref
2	74585	• Sub-Assembly, 2 Spool Valve (See Group 80, Figure 17 for DET)					1
3		• Tee, Special Drill					1
4	78593	• Fitting, Mini Check (Port)					1
5		• Fitting, 90					1
6		• Controller, Check					1
7		• Tee					1
8		• Fitting					2
9		• Fitting, Connector					2
10		• Tee					1
11		• Fitting, 90					2
12		• Fitting, 90					1
13		• Tee, Special Drill					1
14		• Fitting, 90					1
15		• Bolt, Hex					2
16		• Washer, SPL Lock					2
		DASH(-) ITEM NOT ILLUSTRATED					



2 SPOOL VALVE SUB-ASSEMBLY

C50HP
PARTS
GROUP 80
FIGURE 17
PAGE 01

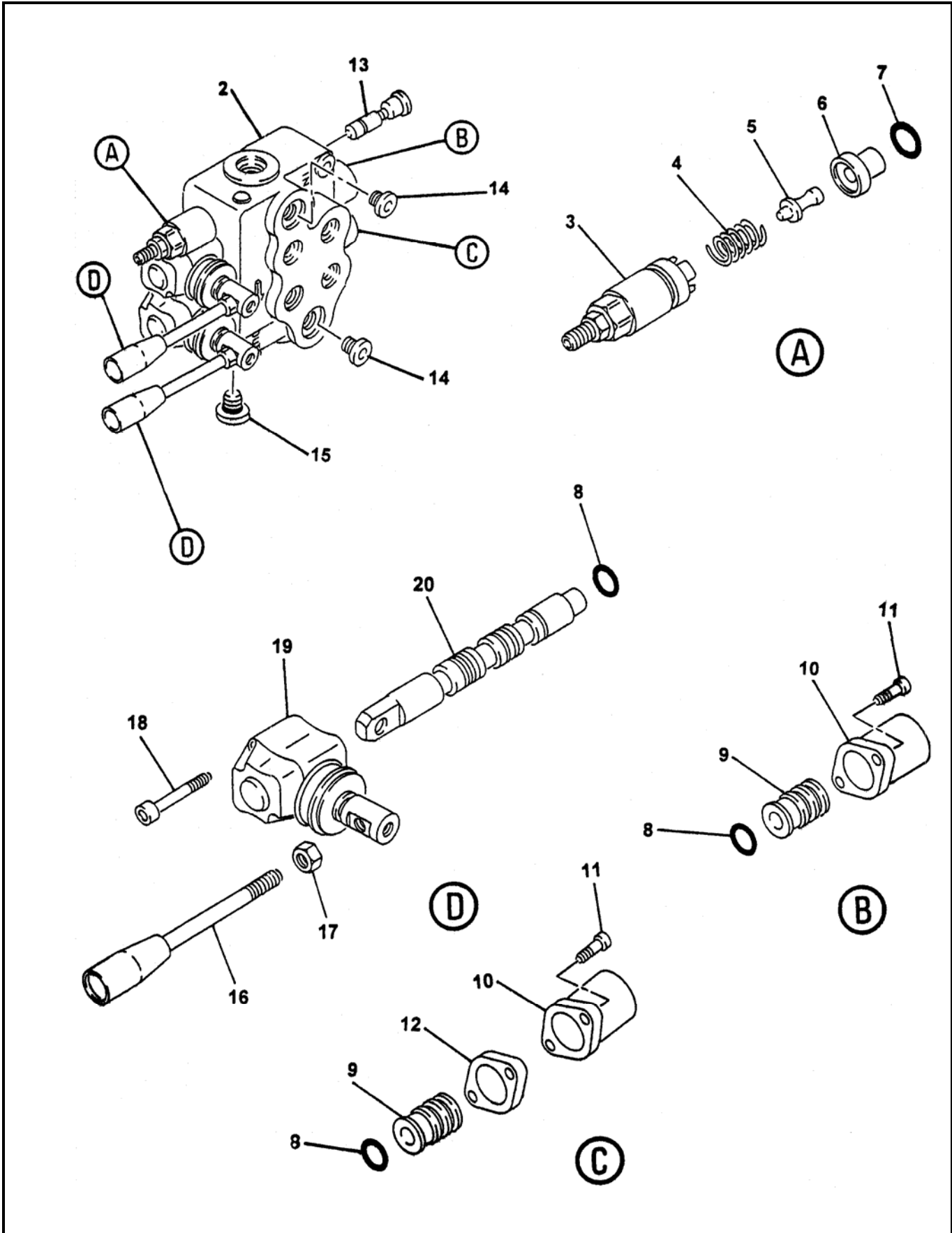

REVISION:



2 SPOOL VALVE SUB-ASSEMBLY

C50HP
PARTS
GROUP 80
FIGURE 17
PAGE 02

ITEM NO.	REED'S PARTS NO.	DESCRIPTION					QTY
		1	2	3	4	5	
-1	74585	Sub-Assembly, 2 Spool Valve (See Group 80, Figure 17 for NHA)					Ref
2		• Body, Valve					1
3		• Kit, Screw					1
4		• Spring					1
5		• Pin, Screw Kit					1
6		• Ring					1
7		• O-Ring					1
8		• O-Ring					4
9		• Kit, Spool Control					2
10		• Cap, Spool					2
11		• Screw, SOC (attaching Parts)					4
12		• Spacer					1
13		• Kit, VRS					1
14		• Plug					2
15		• Plug					1
16		• Handle, Remixer Valve					2
17		• Nut (attaching parts)					2
18		• Screw, SOC					4
19		• Lever, L					2
20		• Spool					2
		DASH (-) ITEM NOT ILLUSTRATED					