



**REED TRAILER MOUNTED CONCRETE PUMP 01 MODEL B60 ILLUSTRATED PARTS MANUAL CONTAINS THE FOLLOWING GROUPS AND FIGURES:**

**GROUP 00 HOW TO USE PARTS MANUAL**

- FIGURE 00** TABLE OF CONTENTS
- FIGURE 01** HOW TO USE PARTS MANUAL
- FIGURE 02** HOW TO ORDER PARTS

**GROUP 10 FINAL INSTALLATION**

- FIGURE 00** TABLE OF CONTENTS
- FIGURE 01** STANDARD HOPPER WITH SINGLE SHIFT INSTALLATION
- FIGURE 02** HARSH MIX HOPPER WITH SINGLE SHIFT INSTALLATION
- FIGURE 03** STANDARD HOPPER WITH DUAL SHIFT INSTALLATION
- FIGURE 04** HARSH MIX HOPPER WITH DUAL SHIFT INSTALLATION
- FIGURE 05** DECAL ASSEMBLY

**GROUP 20 HOPPER INSTALLATION**

- FIGURE 00** TABLE OF CONTENTS
- FIGURE 01** STANDARD HOPPER INSTALLATION
- FIGURE 02** HARSH MIX HOPPER INSTALLATION
- FIGURE 03** HOPPER CLEAN OUT DOOR ASSEMBLY
- FIGURE 04** STANDARD HOPPER AGITATOR ASSEMBLY
- FIGURE 05** HARSH MIX HOPPER AGITATOR ASSEMBLY
- FIGURE 06** STANDARD HOPPER AGITATOR MOTOR ASSEMBLY
- FIGURE 07** HARSH MIX HOPPER AGITATOR MOTOR ASSEMBLY
- FIGURE 08** 3 SPOOL CONTROL VALVE ASSEMBLY
- FIGURE 09** 3 SPOOL CONTROL VALVE SUB-ASSEMBLY



# TRAILER MOUNTED PUMP 01 MODEL B60 ILLUSTRATED PART MANUAL

01 B60

PARTS

GROUP 00

FIGURE 00

PAGE 02

## GROUP 30 TANK INSTALLATION

FIGURE 00	TABLE OF CONTENTS
FIGURE 01	TANK INSTALLATION
FIGURE 02	HYDRAULIC TANK ASSEMBLY
FIGURE 03	SWING TUBE CIRCUIT MANIFOLD ASSEMBLY
FIGURE 04	SWING TUBE CIRCUIT MAIN SOLENOID VALVE ASSEMBLY
FIGURE 05	SWING TUBE CIRCUIT PILOT SOLENOID VALVE ASSEMBLY
FIGURE 06	BALL VALVE ASSEMBLY
FIGURE 07	DRIVE CYLINDER CIRCUIT MANIFOLD ASSEMBLY
FIGURE 08	DRIVE CYLINDER CIRCUIT MAIN SOLENOID VALVE ASSEMBLY
FIGURE 09	DRIVE CYLINDER CIRCUIT PILOT SOLENOID VALVE ASSEMBLY
FIGURE 10	ACCUMULATOR ASSEMBLY
FIGURE 11	ACCUMULATOR BLADDER REPAIR KIT

## GROUP 40 POWER TRAIN INSTALLATION

FIGURE 00	TABLE OF CONTENTS
FIGURE 01	POWER TRAIN INSTALLATION
FIGURE 02	HYDRAULIC PUMPS ASSEMBLY
FIGURE 03	SINGLE AUXILIARY PUMP ASSEMBLY
FIGURE 04	DOUBLE AUXILIARY PUMP ASSEMBLY
FIGURE 05	MAIN PUMP ASSEMBLY
FIGURE 06	BATTERY MOUNTING ASSEMBLY

## GROUP 50 CONTROLS INSTALLATION

FIGURE 00	TABLE OF CONTENTS
FIGURE 01	CONTROLS INSTALLATION
FIGURE 02	CONTROL BOX ASSEMBLY
FIGURE 03	50 FEET CABLE REMOTE CONTROL ASSEMBLY
FIGURE 04	100 FEET CABLE REMOTE CONTROL ASSEMBLY
FIGURE 05	RADIO REMOTE CONTROL ASSEMBLY

## GROUP 60 PUMPING TRAIN INSTALLATION

FIGURE 00	TABLE OF CONTENTS
FIGURE 01	SINGLE SHIFT PUMPING TRAIN INSTALLATION
FIGURE 02	DUAL SHIFT PUMPING TRAIN INSTALLATION
FIGURE 03	SINGLE SHIFT SWING VALVE ASSEMBLY
FIGURE 04	DUAL SHIFT SWING VALVE ASSEMBLY
FIGURE 05	SINGLE SHIFT SWING RAM CYLINDER SUB-ASSEMBLY
FIGURE 06	DUAL SHIFT SWING RAM CYLINDER SUB-ASSEMBLY
FIGURE 07	MATERIAL CYLINDER ASSEMBLY
FIGURE 08	FLUSHBOX ASSEMBLY
FIGURE 09	HYDRAULIC DRIVE CYLINDER ASSEMBLY
FIGURE 10	HYDRAULIC DRIVE CYLINDER SUB-ASSEMBLY

REVISION:



# TRAILER MOUNTED PUMP 01 MODEL B60 ILLUSTRATED PART MANUAL

01 B60

PARTS

GROUP 00

FIGURE 00

PAGE 03

## GROUP 70 FRAME INSTALLATION

- FIGURE 00 TABLE OF CONTENTS
- FIGURE 01 FRAME INSTALLATION
- FIGURE 02 HUB AND BRAKE ASSEMBLY
- FIGURE 03 NON-OPERATOR SIDE ELECTRIC BRAKE ASSEMBLY
- FIGURE 04 OPERATOR SIDE ELECTRIC BRAKE ASSEMBLY

## GROUP 80 OPTIONAL INSTALLATION

- FIGURE 00 TABLE OF CONTENTS
- FIGURE 01 OPTIONAL INSTALLATION
- FIGURE 02 LUBE SYSTEM ASSEMBLY
- FIGURE 03 12 VOLT LUBE PUMP ASSEMBLY
- FIGURE 04 HOPPER VIBRATOR ASSEMBLY
- FIGURE 05 THROTTLE SOLENOID ASSEMBLY
- FIGURE 06 ACCUMULATOR CHARGE KIT
- FIGURE 07 OPTIONAL TOOL KIT ASSEMBLY
- FIGURE 08 ACTUATOR BRAKES ASSEMBLY
- FIGURE 09 WATER PUMP INSTALLATION
- FIGURE 10 WATER PUMP CONTROL VALVE ASSEMBLY
- FIGURE 11 WATER PUMP MOTOR ASSEMBLY
- FIGURE 12 WATER PUMP ASSEMBLY
- FIGURE 13 NON-OPERATOR SIDE HYDRAULIC BRAKE ASSEMBLY
- FIGURE 14 OPERATOR SIDE HYDRAULIC BRAKE ASSEMBLY
- FIGURE 15 HYDRAULIC OUTRIGGER CYLINDER ASSEMBLY
- FIGURE 16 1 SPOOL CONTROL VALVE ASSEMBLY
- FIGURE 17 1 SPOOL CONTROL VALVE SUB-ASSEMBLY
- FIGURE 18 2 SPOOL CONTROL VALVE ASSEMBLY
- FIGURE 19 2 SPOOL CONTROL VALVE SUB-ASSEMBLY
- FIGURE 20 SIDE DOOR ASSEMBLY
- FIGURE 21 50 FEET STROKE COUNTER REMOTE CONTROLLER
- FIGURE 22 100 FEET STROKE COUNTER REMOTE CONTROLLER



# TRAILER MOUNTED PUMP 01 MODEL B60 HOW TO USE PART MANUAL

01 B60  
PARTS  
GROUP 00  
FIGURE 01  
PAGE 01

## I. PURPOSE

This parts manual is prepared, issued and/or revised by **REED** Manufacturing, for the exclusive use of its customers and is intended for use in provisioning, requisitioning, storing and issuing replaceable **REED** trailer mounted pump **01** model **B60**. The contents are proprietary to **REED** and are subject to change without notice. The use of any part of this document by any other person or persons or for any other purpose without the written consent of **REED** is expressly prohibited. In addition, **REED** expressly disclaims any and all responsibility arising in or any way related to such **REED's** prior written consent thereto.

The parts number content of this document, arrangement and breakdown sequence of items is compatible with Military Standard (**MS**) and Air Transport Association Specification (**ATA**).

## II. GENERAL SYSTEM OF ASSEMBLY ORDER – Detailed Parts List (Refer to Next Page)

1. This area refers to the corresponding illustration

### MODEL – GROUP – FIGURE – PAGE

A. **MODEL** shows which is **REED's** model number.

B. **GROUP** should be divided with:

00	01 MODEL B60 PARTS MANUAL
10	FINAL INSTALLATION
20	HOPPER INSTALLATION
30	TANK INSTALLATION
40	POWER TRAIN INSTALLATION
50	CONTROL INSTALLATION
60	PUMPING TRAIN INSTALLATION
70	FRAME INSTALLATION
80	OPTIONAL INSTALLATION

C. **FIGURE** belong to the group. Please see page of contents and each group.

D. **PAGE** numbers follow to the right of each figure number.

2. The **ITEM NUMBER** corresponds to the item number shown for the part in illustration. Parts with item number preceded by a dash (such as: -1, -5, -12 etc.) are not illustrated.

3. **PARTS NUMBERS** that carry a **REED** part number.



# TRAILER MOUNTED PUMP 01 MODEL B60 HOW TO USE PART MANUAL

01 B60  
PARTS  
GROUP 00  
FIGURE 01  
PAGE 02

## DUAL SHIFT SWING VALVE ASSEMBLY

01 B40  
PARTS  
GROUP 60  
FIGURE 04  
PAGE 02

ITEM NO.	REED'S PARTS NO.	DESCRIPTION					QTY
		1	2	3	4	5	
-1	60-04	Assembly, Dual Shift Swing Valve (See Group 60, Figure 02 for NHA)					Ref
-2	86321	• Assembly, Outlet Group					1
3		•• Nut					6
4	72482	•• Outlet, Machine 5"					1
5		•• Fitting, Grease					2
6	79895	•• Kit, Outlet Seal					1
7	77761	••• O-Ring, Large					1
8	77762	••• O-Ring, Small					1
9	86504	•• Seal, Modified Outlet Thick					1
10	77763	••• Band, Guide					1
11	77765	••• Seal, Outlet Thick					1
12	72309	•• Housing, Outlet Seal					1
13		•• Bolt, Hex					6
14		•• Nut, Nylock (attaching parts)					6
15		•• Washer, Lock (attaching parts)					6
16	70042	•• Outlet, Chromed					1
17		•• Bolt, Hex (attaching parts)					6
-18	86317	• Assembly, Swing Tube Group					1
19	85965	•• Weldment, Harsh Swing Tube					1
20	86065	•• Seal, 6 Inch Single Lip					1
21	72310	•• Ring, 6 Inch Single Lip Wear					1
22	86031	•• Plate, Wear					1
23	86086	•• Ring, Anti Chip					2
24		•• Bolt, Flat Head					4
25		•• Washer, Lock					4
26		•• Nut, Hex					4
27		•• Bolt, Hex					6
28		•• Washer, Lock					6
29	85962	•• Seal, Flange Bearing					1
30		•• Pin, Dowel					1
31		•• Fitting, Grease 90					2
32	85133	•• Bearing, 3 Inch Spline Flange					1
33	85294	•• Washer, Thrust					1
34	85134	•• Spacer, Swing Tube Nut					1
35	70825	•• Nut, Swing Tube					1
36		•• Pin Cotter					1
-37	86320	• Assembly, Swing Tube Dual Shift Group					1
38		•• Plug, Pipe					4
39	86052	•• Pin, Spring					4
40		•• Fitting, Grease 90					2
41	86441	•• Retainer, Swing Ram					2

DASH (-) ITEM NOT ILLUSTRATED

REVISION:

REVISION:



# TRAILER MOUNTED PUMP 01 MODEL B60 HOW TO USE PART MANUAL

01 B60  
PARTS  
GROUP 00  
FIGURE 01  
PAGE 03



## DUAL SHIFT SWING VALVE ASSEMBLY

01 B40  
PARTS  
GROUP 60  
FIGURE 04  
PAGE 02

ITEM NO.	REED'S PARTS NO.	DESCRIPTION					QTY
		1	2	3	4	5	
-1	60-04	Assembly, Dual Shift Swing Valve (See Group 60, Figure 02 for NHA)					Ref
-2	86321	• Assembly, Outlet Group					1
3		• • Nut					6
4	72482	• • Outlet, Machine 5"					1
5		• • Fitting, Grease					2
6	79895	• • Kit, Outlet Seal					1
7	77761	• • • O-Ring, Large					1
8	77762	• • • O-Ring, Small					1
9	86504	• • • Seal, Modified Outlet Thick					1
10	77763	• • • Band, Guide					1
11	77765	• • • Seal, Outlet Thick					1
12	72309	• • Housing, Outlet Seal					1
13		• • Bolt, Hex					6
14		• • Nut, Nylock (attaching parts)					6
15		• • Washer, Lock (attaching parts)					6
16	70042	• • Outlet, Chromed					1
17		• • Bolt, Hex (attaching parts)					6
-18	86317	• Assembly, Swing Tube Group					1
19	85965	• • Weldment, Harsh Swing Tube					1
20	86065	• • Seal, 6 Inch Single Lip					1
21	72310	• • Ring, 6 Inch Single Lip Wear					1
22	86031	• • Plate, Wear					1
23	86086	• • Ring, Anti Chip					2
24		• • Bolt, Flat Head					4
25		• • Washer, Lock					4
26		• • Nut, Hex					4
27		• • Bolt, Hex					6
28		• • Washer, Lock					6
29	85962	• • Seal, Flange Bearing					1
30		• • Pin, Dowel					1
31		• • Fitting, Grease 90					2
32	85133	• • Bearing, 3 Inch Spline Flange					1
33	85294	• • Washer, Thrust					1
34	85134	• • Spacer, Swing Tube Nut					1
35	70825	• • Nut, Swing Tube					1
36		• • Pin Cotter					1
-37	86320	• Assembly, Swing Tube Dual Shift Group					1
38		• • Plug, Pipe					4
39	86052	• • Pin, Spring					4
40		• • Fitting, Grease 90					2
41	86441	• • Retainer, Swing Ram					2

DASH (-) ITEM NOT ILLUSTRATED

REVISION:



REVISION:



# TRAILER MOUNTED PUMP 01 MODEL B60 HOW TO USE PART MANUAL

01 B60  
PARTS  
GROUP 00  
FIGURE 01  
PAGE 04

## 4. DESCRIPTION

A. The **INDENTURE SYSTEM** used in the parts list shows the relationship of one part to another. For a given item, the number of indentures depicts the relationship of the item to the components of the item as follows:

1 2 3 4 5

Assembly (or Installation)

- Detail part of assembly
- Sub-assembly
- Attaching parts for sub-assembly
- • Detail part of sub-assembly
- • Sub-sub-assembly
- • Attaching parts for sub-sub-assembly
- • • Detail part of sub-sub-assembly
- • • Sub-sub-sub-assembly
- • • Attaching parts of sub-sub-sub-assembly
- • • • Detail part of sub-sub-sub-assembly

B. "See Group 60, Figure 02 For **NHA**"

Identifies the illustrated parts chapter location; indicates where the Next Higher Assembly (**NHA**) of the item shown.

C. "See Group 60, Figure 07 For **DET**"

Identifies the illustrated parts chapter location; indicates where the item and its Detailed Breakdown (**DET**) is shown.

D. "See Group 30, Figure 05 for **REF**" or "See Vendor Chapter For **REF**"

Identifies the illustrated parts chapter where the part is, and if listed and illustrated in Vendor Chapter. It is used as a cross-reference (**REF**).

## 5. QUANTITY

A. Reference (**REF**) indicates the items that is listed previously in the Next Higher Assembly (**NHA**) and then again in this figure.

B. As Required (**A/R**) indicates the parts that is used in a quantity as required.

C. A number entry indicates the quantity of the part used in its next higher application.

6. Functionally related assemblies are illustrated in phantom (— — — —) but not listed on the detail parts list page.



# TRAILER MOUNTED PUMP 01 MODEL B60 HOW TO ORDER PARTS

**01 B60**  
**PARTS**  
GROUP 00  
FIGURE 02  
PAGE 01

1. Always give serial number and model of **REED** trailer mounted concrete pump 01 model **B60**. (Refer to each unit name plate shown below). NOTE: This manual is being released to cover unit starting with serial number **3-03-1-2061** to current production. Some components used on earlier units differ from current productions. Where this occurs, the part is identified by a serial number.

<b>REED</b>		PHONE (909) 287 - 2100	
13822 OAKS AVENUE		FAX (909) 287 - 2140	
CHINO, CA 91710 USA			
MODEL	_____	SERIAL NO	_____
MATERIAL PRESSURE	_____	PSI	_____ 3AR
HYDRAULIC PRESSURE	_____	PSI	_____ 3AR
ENGINE / PTO ELECTRIC MOTOR	_____	RPM	_____ /OLTS
PN 36636			

2. Always specify part number and complete name of parts ordered.

- A. Turn to table of content in the desired Installation. Refer to main group in which part should be listed.
- B. Find title of figure in which the part should be shown. Note figure number.

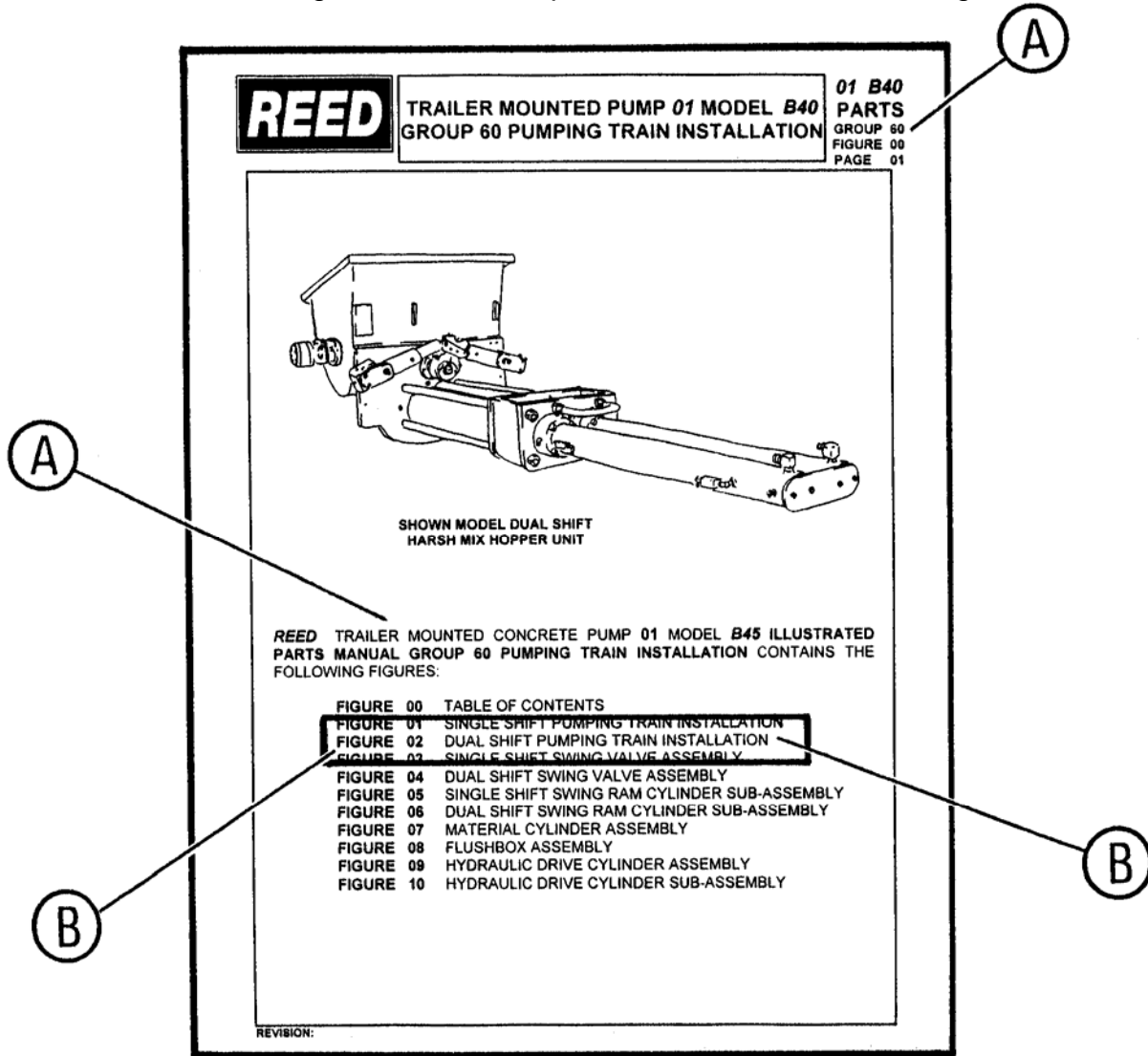

REVISION:





# TRAILER MOUNTED PUMP 01 MODEL B60 HOW TO ORDER PARTS

01 B60  
PARTS  
GROUP 00  
FIGURE 02  
PAGE 02

**REED** DUAL SHIFT SWING VALVE ASSEMBLY  
01 B40 PARTS GROUP 00 FIGURE 04 PAGE 01

HOPPER REF (STANDARD P/N: 86107) (HARSH MIX P/N: 86032)

SWING RAM HOUSE REF (RH P/N: 85941) (LH P/N: 85942)

HOPPER REF (STANDARD P/N: 86107) (HARSH MIX P/N: 86032)

REVISION:

**REED** DUAL SHIFT SWING VALVE ASSEMBLY  
01 B40 PARTS GROUP 00 FIGURE 04 PAGE 02

ITEM NO.	REED'S PARTS NO.	DESCRIPTION	QTY
-1	60-04	Assembly, Dual Shift Swing Valve (See Group 60, Figure 02 for NHA)	Ref
-2	86321	• Assembly, Outlet Group	1
3		• • Nut	6
4	72482	• • Outlet, Machine 5"	1
5		• • Fitting, Grease	2
6	79895	• • Kit, Outlet Seal	1
7	77761	• • • O-Ring, Large	1
8	77762	• • • O-Ring, Small	1
9	86504	• • • Seal, Modified Outlet Thick	1
10	77763	• • • Band, Guide	1
11	77765	• • • Seal, Outlet Thick	1
12	72309	• • Housing, Outlet Seal	1
13		• • Bolt, Hex	6
14		• • Nut, Nylock (attaching parts)	6
15		• • Washer, Lock (attaching parts)	6
16	70042	• • Outlet, Chromed	1
17		• • Bolt, Hex (attaching parts)	6
-18	86317	• Assembly, Swing Tube Group	1
19	85965	• • Weldment, Harsh Swing Tube	1
20	86085	• • Seal, 6 Inch Single Lip	1
21	72310	• • Ring, 6 Inch Single Lip Wear	1
22	86031	• • Plate, Wear	1
23	86086	• • Ring, Anti Chip	2
24		• • Bolt, Flat Head	4
25		• • Washer, Lock	4
26		• • Nut, Hex	4
27		• • Bolt, Hex	6
28		• • Washer, Lock	6
29	85962	• • Seal, Flange Bearing	1
30		• • Pin, Dowel	1
31		• • Fitting, Grease 90	2
32	86793	• • Bearing, 3 Inch Spine Flange	1
33	85294	• • Washer, Thrust	1
34	86787	• • Spacer, Swing Tube Rod	1
35	70625	• • Nut, Swing Tube	1
36		• • Pin Cotter	1
-37	86320	• Assembly, Swing Tube Dual Shift Group	1
38		• • Plug, Pipe	4
39	86082	• • Pin, Spring	4
40		• • Fitting, Grease 90	2
41	86441	• • Retainer, Swing Ram	2

DASH (-) ITEM NOT ILLUSTRATED

REVISION:

- C. Turn to corresponding page, find the group and figure.
- D. Check your required part and its attaching parts and match with illustration page.
- E. Refer to corresponding item number in the part list page. Part numbers are located in the part number column.
- F. When ordering variable or optional miscellaneous parts which are not found this in parts chapter, follow the above outlined procedure of how to order parts.
  - 1). When applicable, give model and serial number of the component for which parts are desired.
  - 2). In a specific, difficult to describe situation, a marked-up photograph or detailed sketch would be helpful.

REVISION:



**TRAILER MOUNTED PUMP 01 MODEL B60  
HOW TO ORDER PARTS**

**01 B60**

**PARTS**

GROUP 00

FIGURE 02

PAGE 03

3. Do not designate quantity by "set". State specifically how many parts are wanted.
4. Always give complete address and full shipping instructions. Specify shipping instructions, truck freight, air freight. United Parcel Service (UPS), or FedEx and DHL are available in designated areas.

**5. TO ORDER**

**A. BY MAIL**

Attention: Parts Department

**REED**

13822 Oaks Avenue  
Chino, CA. 91710

**B. BY FAX**

(909) 287 - 2141

**C. BY PHONE**

(909) 287 - 2100

6. Parts return without authorization will not be accepted. If it is necessary to return parts for any reason, written authorization may be obtained from **REED** Parts Department, Chino, CA. 91710. A Parts Return Authorization form is provided when **REED** deems its necessary to have the part returned for evaluation. The form is issued by the Warranty of Parts Department of **REED**.
  - A. The form will be filled by **REED** unless requesting necessary information and you will receive a copy as well as shipping tag.
  - B. Attach shipping tag to part insert return original invoice.
  - C. Ship part to **REED PREPAID**.
  - D. Part must be returned to **REED** within 30 days from date of authorization.

**REED TRAILER MOUNTED CONCRETE PUMP 01 MODEL B60 ILLUSTRATED PARTS MANUAL GROUP 10 FINAL INSTALLATION CONTAINS THE FOLLOWING FIGURES:**

- FIGURE 00** TABLE OF CONTENTS
- FIGURE 01** FINAL INSTALLATION
- FIGURE 02** DECAL ASSEMBLY





TRAILER MOUNTED PUMP MODEL B60  
FINAL INSTALLATION

B60  
PARTS  
GROUP 10  
FIGURE 01  
PAGE 01

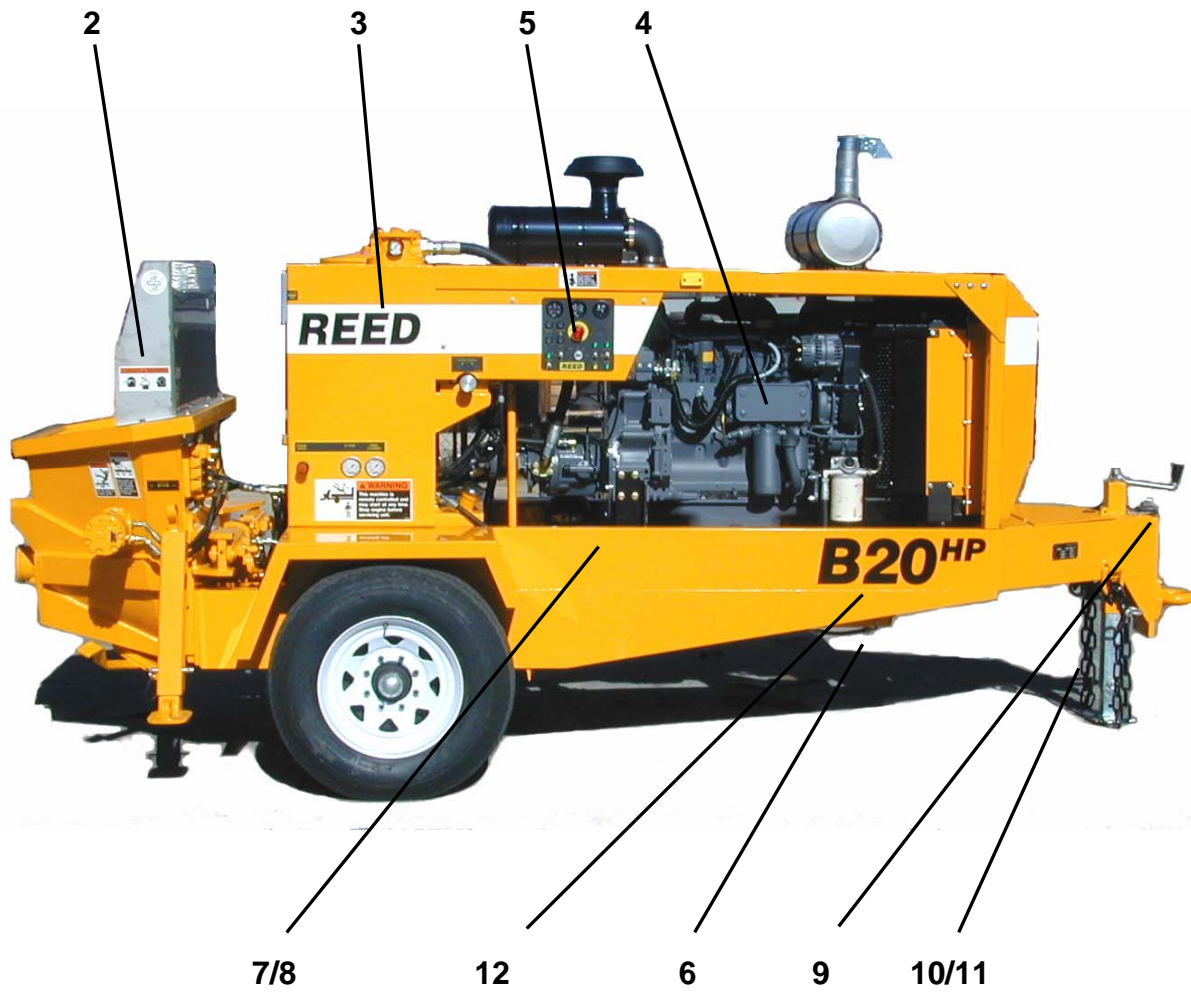

REVISION:



**FINAL INSTALLATION  
GROUP 10 FINAL INSTALLATION**

**B60**  
**PARTS**  
GROUP 10  
FIGURE 01  
PAGE 02

ITEM NO.	REED'S PARTS NO.	DESCRIPTION	QTY
		1 2 3 4 5	
-1	<b>B60C-V01</b>	Installation, <b>B60</b> Final	Ref
2	20-01	• Installation, Hopper (See Group 20, Figure 01 for DET)	1
3	30-01	• Installation, Tank (See Group 30, Figure 01 for DET)	1
4	40-01	• Installation, Power Train (See Group 40, Figure 01 for DET)	1
5	50-01	• Installation, Control (See Group 50, Figure 01 for DET)	1
6	60-01	• Installation, Double Shift Pumping Train (See Group 60, Figure 01 for DET)	1
7	70-01	• Installation, Frame (See Group 70, Figure 01 for DET)	1
8	80-01	• Installation, Optional (See Group 80, Figure 01 for DET)	1
9	77705	• Kit, Break Away	1
10	86730	• Chain	1
11	71049	• Clevis, Double	2
12	10-02	• Kit, <b>B60</b> Decal (See Group 10, Figure 02 for DET)	1

REVISION:



# DECAL ASSEMBLY GROUP 10 FINAL INSTALLATION

B60  
PARTS  
GROUP 10  
FIGURE 02  
PAGE 01

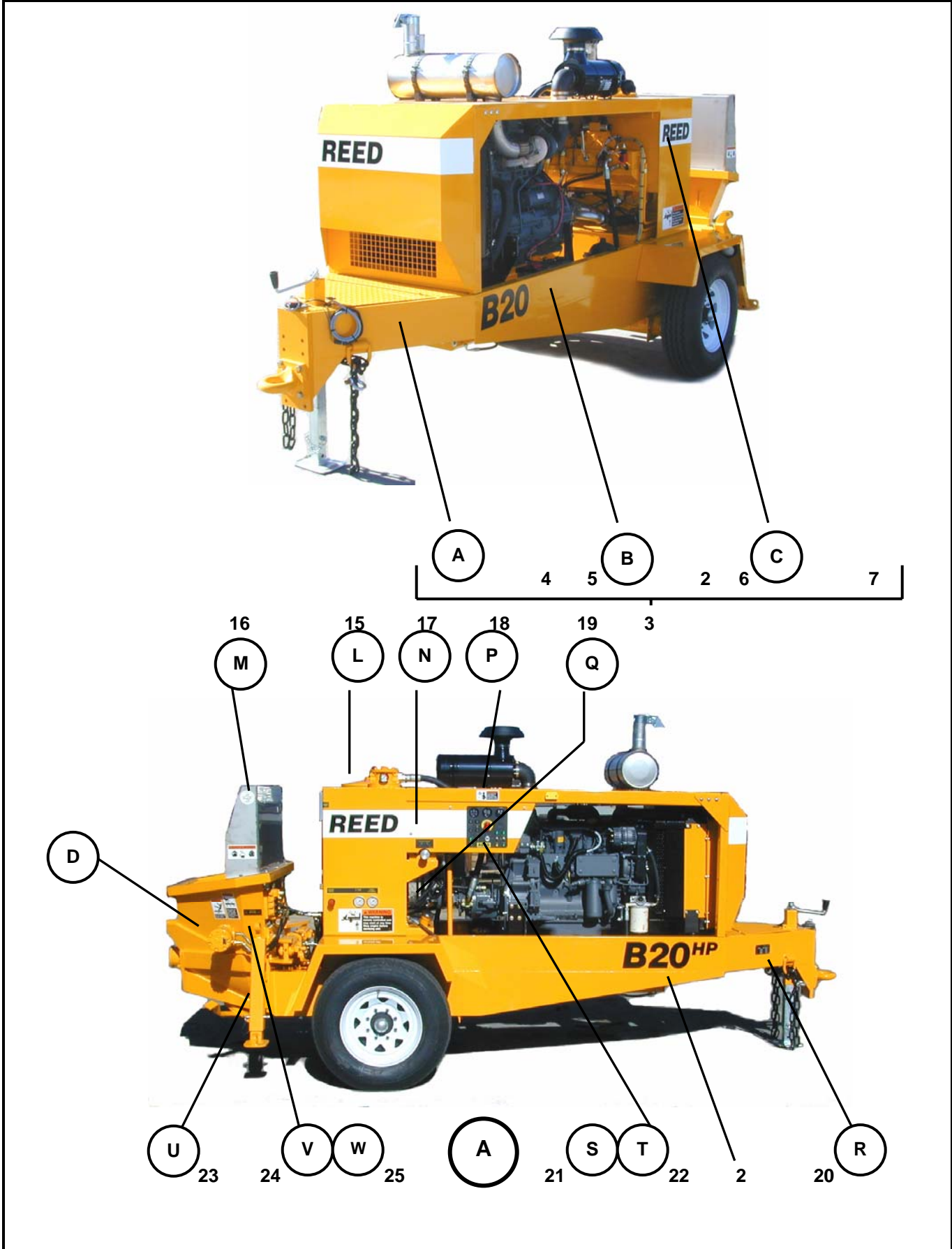

REVISION:



# DECAL ASSEMBLY GROUP 10 FINAL INSTALLATION

**B60**  
**PARTS**  
GROUP 10  
FIGURE 02  
PAGE 02



**! WARNING**

**Keep hands out of waterbox.  
Stop engine/motor if access is required.  
Keep guards in place.**

800916

————— 5



ITEM NO.	REED'S PARTS NO.	DESCRIPTION	QTY
		1 2 3 4 5	
-1	10-02	Kit, <b>B60</b> Decal (See Group 10, Figure 01 for NHA)	Ref
2	86805	• Decal, <b>B60</b> 6 Inch Black	2
3	85425	• Kit, B-Series Decal	1
4	85418	•• Decal, <b>REED</b> 4 1/2 Inch Black and White 48 Inch	2
5	800916	•• Decal, Warning, Keep Hand Out of Water Box	1
6	800924	•• Decal, Warning, This Machine is Remote Controlled and	2
7	85416	•• Decal, <b>REED</b> 4 1/2 Inch Black and White 20 Inch	1
8	800922	•• Decal, Warning, Before Opening a Blocked Pipeline,	1
9	800921	•• Decal, Warning, Do Not Operate at Pressures Exceeding	1
10	73132	•• Decal, <b>REED</b> 4 1/2 Inch	1
11	800929A	•• Decal, Warning	2
12	800917	•• Decal, Warning, Keep Hand Out of Hopper and Valve	2
13	800918	•• Decal, Warning, Do Not Stand on Hopper Grate	2
14	85684	•• Decal, B-Series Gauges	1
15	75020	•• Decal, Hydraulic Oil	1
16	800931	•• Decal, <b>ACPA</b> Member	1
17	85413	•• Decal, Volume Control	1
18	800926	•• Decal, Warning, Do Not Operate This Machine without	1
19	75017	•• Decal, Diesel Fuel Only	1
20	75009	•• Nameplate, <b>REED</b> , Serial No.	1
21	85332	• Decal, Control Box Panel	1
22	85410	• Decal, Remote Control	1
23	800919	• Decal, Optional, Warning, Stand Clear Outriggers When	2
24	85845	• Decal, Outriggers	1
25	85846	• Decal, Agitator	1

REVISION:



**! WARNING**

This machine is remote controlled and may start at any time. Stop engine before servicing unit.

800923

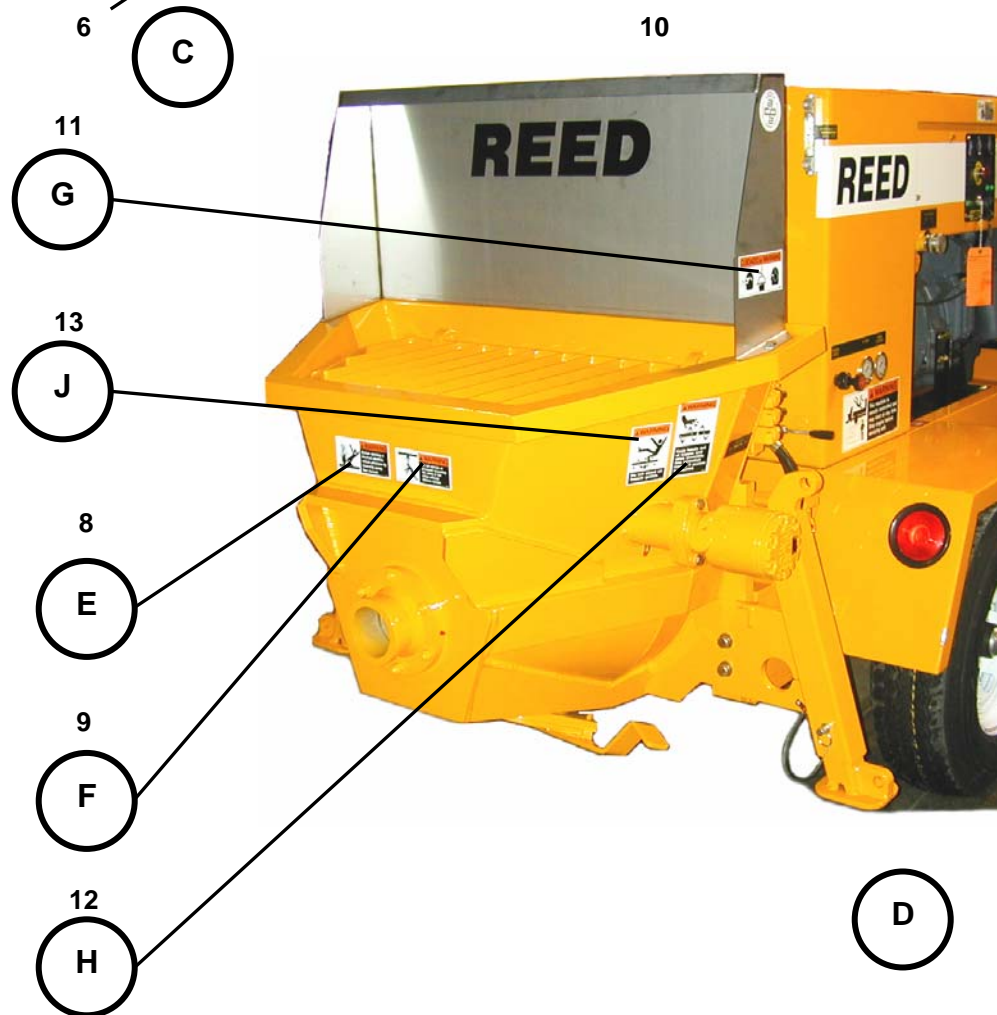





**⚠ WARNING**  
Before opening a  
blocked pipeline,  
relieve pressure by  
reversing pump.  
See manual.

800922

8

(E)



**⚠ WARNING**  
Keep hands out  
of hopper and  
valve assembly.  
See operation  
manual if access  
is required.

800917

(H)

12

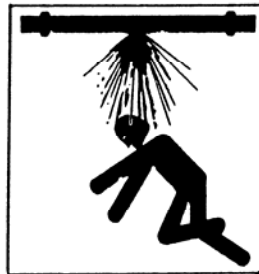

**⚠ WARNING**  
Do not operate at  
pressures exceeding  
the rating of the  
entire material  
delivery system.

800921

9

(F)

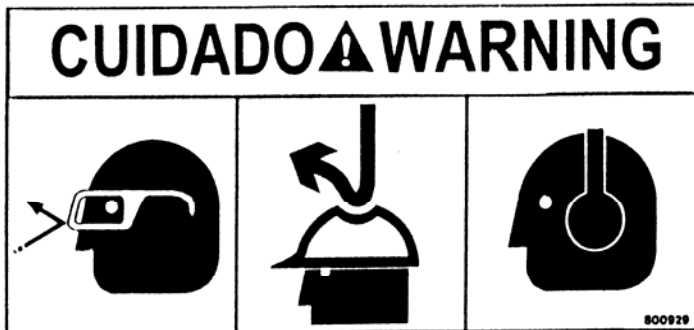

800929

(G)

11



**DECAL ASSEMBLY  
GROUP 10 FINAL INSTALLATION**

B60  
**PARTS**  
GROUP 10  
FIGURE 02  
PAGE 05



13

(J)

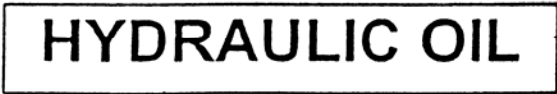

15

(L)

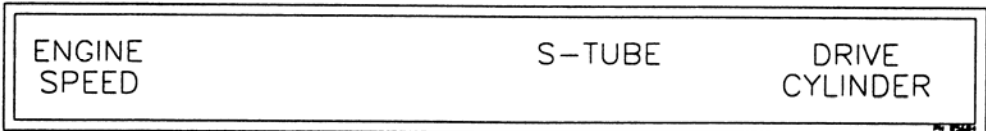

14

(K)

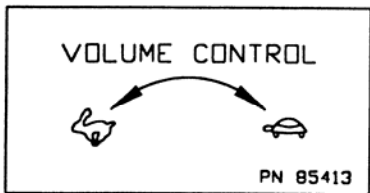

17

(N)



16

(M)



# DECAL ASSEMBLY GROUP 10 FINAL INSTALLATION

B60  
PARTS  
GROUP 10  
FIGURE 02  
PAGE 06



(P)

18



19

(Q)

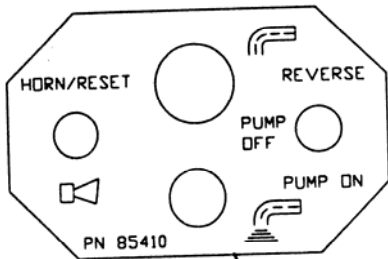

(T)

22

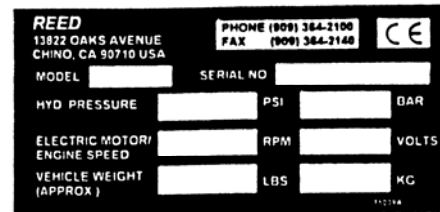

20

(R)

21

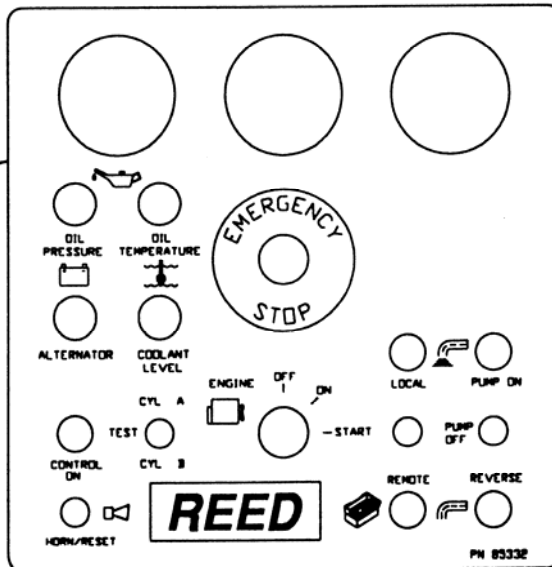

(S)



**DECAL ASSEMBLY  
GROUP 10 FINAL INSTALLATION**

**B60  
PARTS  
GROUP 10  
FIGURE 02  
PAGE 07**

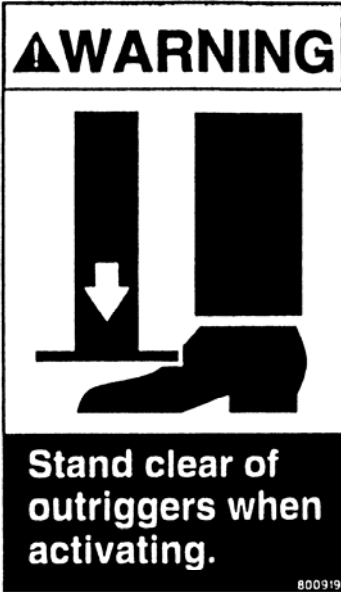

23

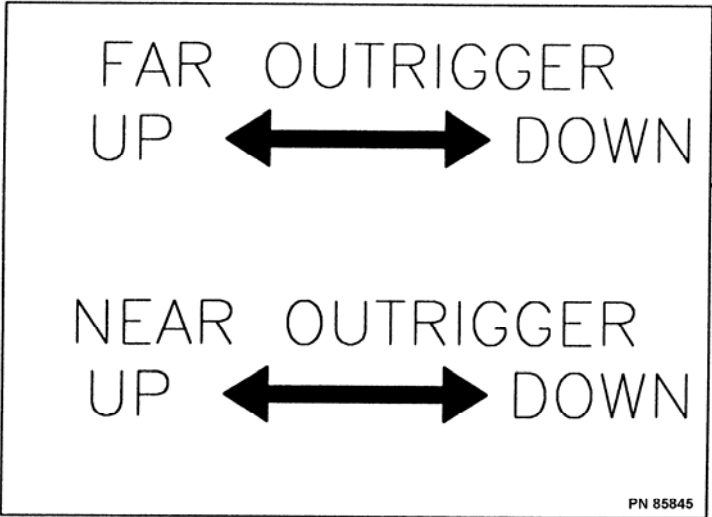

24

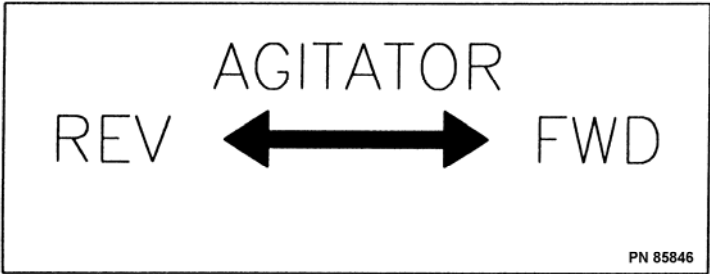

25





**DECAL ASSEMBLY  
GROUP 10 FINAL INSTALLATION**

**B60  
PARTS  
GROUP 10  
FIGURE 02  
PAGE 08**

ITEM NO.	REED'S PARTS NO.	DESCRIPTION	QTY
		1 2 3 4 5	
-1	10-02	Kit, <b>B60</b> Decal (See Group 10, Figure 01 for NHA)	Ref
2	86805	• Decal, <b>B60</b> 6 Inch Black	2
3	85425	• Kit, B-Series Decal	1
4	85418	•• Decal, <b>REED</b> 4 1/2 Inch Black and White 48 Inch	2
5	800916	•• Decal, Warning, Keep Hand Out of Water Box	1
6	800924	•• Decal, Warning, This Machine is Remote Controlled and	2
7	85416	•• Decal, <b>REED</b> 4 1/2 Inch Black and White 20 Inch	1
8	800922	•• Decal, Warning, Before Opening a Blocked Pipeline,	1
9	800921	•• Decal, Warning, Do Not Operate at Pressures Exceeding	1
10	73132	•• Decal, <b>REED</b> 4 1/2 Inch	1
11	800929A	•• Decal, Warning	2
12	800917	•• Decal, Warning, Keep Hand Out of Hopper and Valve	2
13	800918	•• Decal, Warning, Do Not Stand on Hopper Grate	2
14	85684	•• Decal, B-Series Gauges	1
15	75020	•• Decal, Hydraulic Oil	1
16	800931	•• Decal, <b>ACPA</b> Member	1
17	85413	•• Decal, Volume Control	1
18	800926	•• Decal, Warning, Do Not Operate This Machine without	1
19	75017	•• Decal, Diesel Fuel Only	1
20	75009	•• Nameplate, <b>REED</b> , Serial No.	1
21	85332	• Decal, Control Box Panel	1
22	85410	• Decal, Remote Control	1
23	800919	• Decal, Optional, Warning, Stand Clear Outriggers When	2
24	85845	• Decal, Outriggers	1
25	85846	• Decal, Agitator	1

REVISION:



**DECAL ASSEMBLY  
GROUP 10 FINAL INSTALLATION**

*B60*  
**PARTS**  
GROUP 10  
FIGURE 03  
PAGE 01

THIS PAGE INTENTIONALLY LEFT BLANK.

**REED TRAILER MOUNTED CONCRETE PUMP 01 MODEL B60 ILLUSTRATED PARTS MANUAL GROUP 20 HOPPER INSTALLATION CONTAINS THE FOLLOWING FIGURES:**

- FIGURE 00** TABLE OF CONTENTS
- FIGURE 01** STANDARD HOPPER INSTALLATION
- FIGURE 02** HARSH MIX HOPPER INSTALLATION
- FIGURE 03** HOPPER CLEAN OUT DOOR ASSEMBLY
- FIGURE 04** STANDARD HOPPER AGITATOR ASSEMBLY
- FIGURE 05** HARSH MIX HOPPER AGITATOR ASSEMBLY
- FIGURE 06** STANDARD HOPPER AGITATOR MOTOR ASSEMBLY
- FIGURE 07** HARSH MIX HOPPER AGITATOR MOTOR ASSEMBLY
- FIGURE 08** 3 SPOOL CONTROL VALVE ASSEMBLY
- FIGURE 09** 3 SPOOL CONTROL VALVE SUB-ASSEMBLY

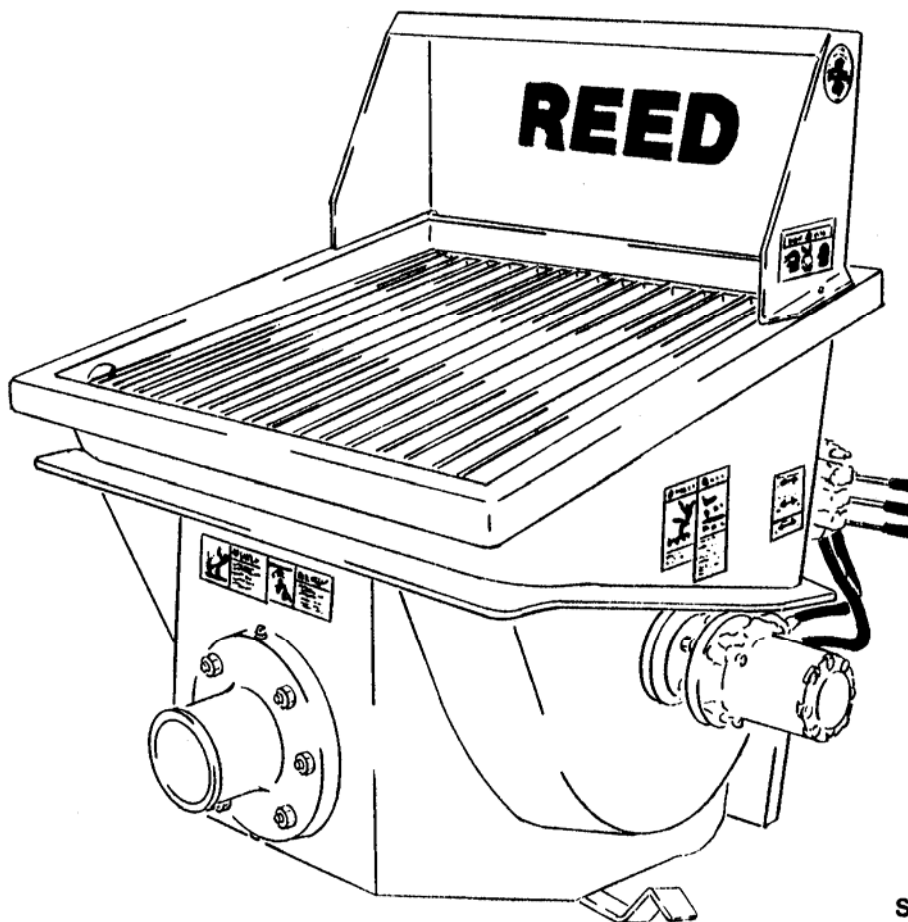

**SHOWN MODEL  
HARSH MIX HOPPER**



# STANDARD HOPPER INSTALLATION

**B60**  
**PARTS**  
GROUP 20  
FIGURE 01  
PAGE 01

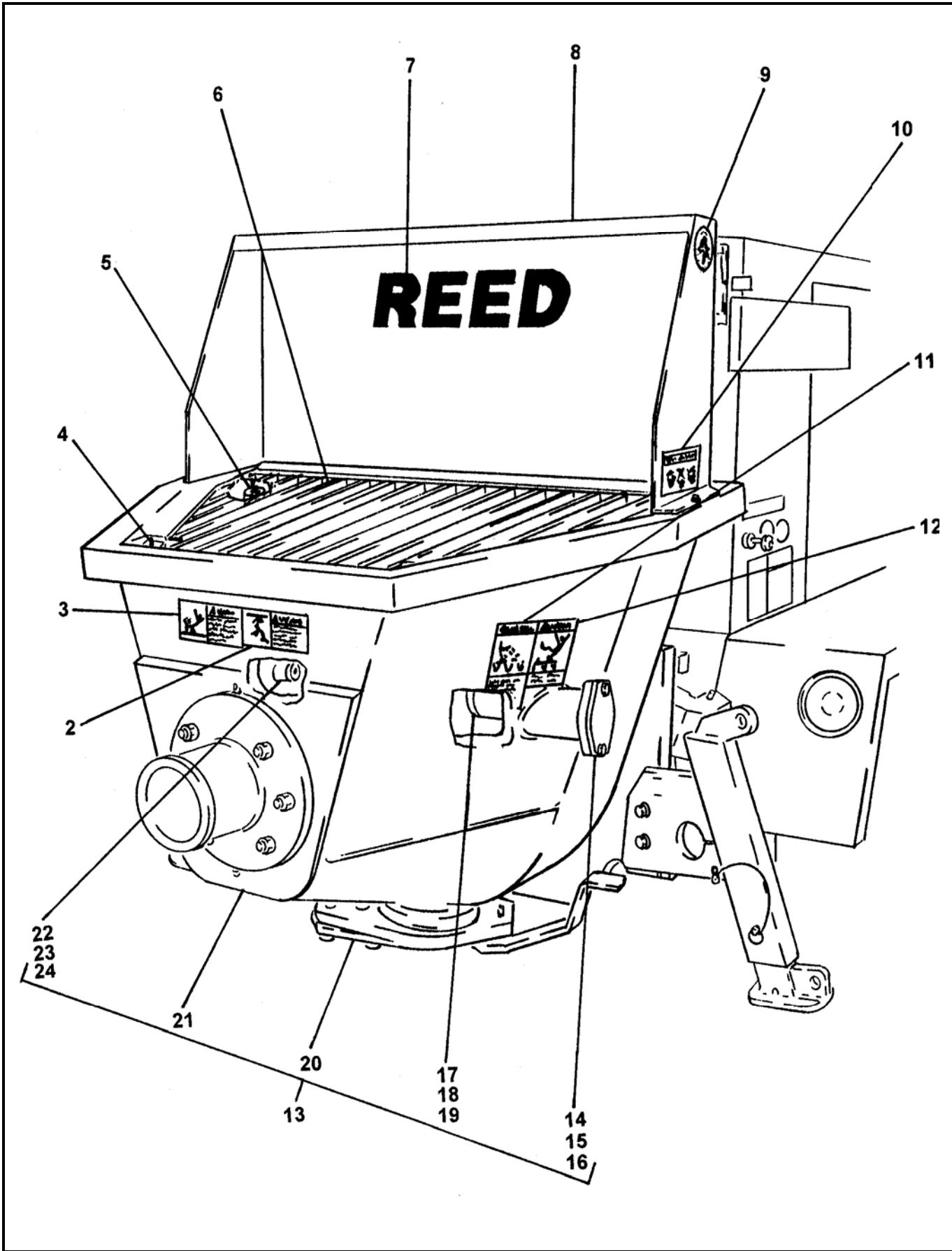

REVISION:





# STANDARD HOPPER INSTALLATION

**B60**  
**PARTS**  
 GROUP 20  
 FIGURE 01  
 PAGE 02

ITEM NO.	REED'S PARTS NO.	DESCRIPTION					QTY
		1	2	3	4	5	
-1	20-01	Installation, Standard Hopper (See Group 10, Figure 01 and Figure 02 for NHA)					Ref
2	800921	• Decal, Warning, Do Not Operate at Pressures Exceeding					1
3	800922	• Decal, Warning, Before Opening a Blocked Pipeline,					1
4	86118	• Mount, Hopper Grate					2
5	86083	• Bumper, Hopper Grate					2
6	86113	• Grate, Standard Hopper					1
7	73132	• Decal, <b>REED</b> 4 1/2 Inch					1
8	85390	• Guard, Splash					1
9	800931	• Decal, <b>ACPA</b> Member					1
10	800929A	• Decal, Warning					2
11	800918	• Decal, Warning, Do Not Stand on Hopper Grate					2
12	800917	• Decal, Warning, Keep Hand Out of Hopper and Valve					2
13	86313	• Assembly, Standard Hopper					1
14	73433	• • Cover, Remix Outside					1
15		• • Bolt, Hex (attaching parts)					2
16		• • Washer, SPL Lock (attaching parts)					2
17	73434	• • Cover, Remix Inside					1
18		• • Bolt, Hex (attaching parts)					6
19		• • Washer, SPL Lock (attaching parts)					6
20	86542	• • Assembly, Clean Out Door (See Group 20, Figure 03 for DET)					1
21	86107	• • Weldment, Standard Hopper					1
22	86623	• • Seal, Agitator					1
23		• • Bolt, Hex (attaching parts)					1
24		• • Washer, Flat (attaching parts)					1
-25	86322	• Assembly, Standard Hopper Agitator (Optional Item) (See Group 20, Figure 04 for DET)					1
-25	20-08	• Assembly, 3 Spool Control Valve (Optional Item) (See Group 20, Figure 08 for DET)					1

DASH (-) ITEM NOT ILLUSTRATED



# HARSH MIX HOPPER INSTALLATION

**B60**  
**PARTS**  
GROUP 20  
FIGURE 02  
PAGE 01

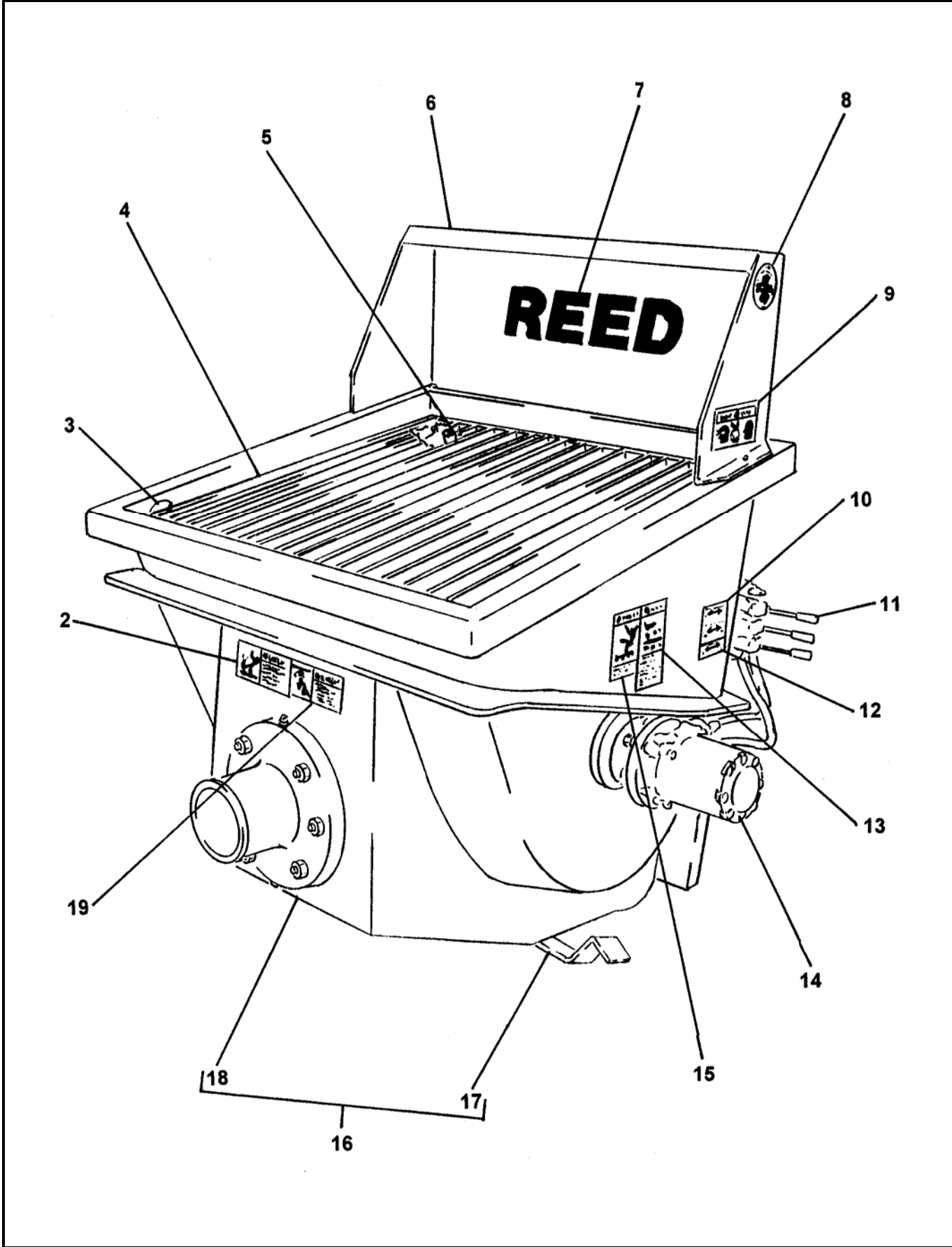

REVISION:



# HARSH MIX HOPPER INSTALLATION

**B60**  
**PARTS**  
GROUP 20  
FIGURE 02  
PAGE 02

ITEM NO.	REED'S PARTS NO.	DESCRIPTION	QTY
		1 2 3 4 5	
-1	20-02	Installation, Harsh Mix Hopper (See Group 10, Figure 03 and Figure 04 for NHA)	Ref
2	800922	• Decal, Warning, Before Opening a Blocked Pipeline,	1
3	86118	• Mount, Hopper Grate	2
4	85982	• Grate, Harsh Mix Hopper	1
5	86083	• Bumper, Hopper Grate	2
6	86084	• Weldment, Splash Guard	1
7	73132	• Decal, <b>REED</b> 4 1/2 Inch	1
8	800931	• Decal, <b>ACPA</b> Member	1
9	800929A	• Decal, Warning	2
10	85845	• Decal, Outriggers (Optional Items)	1
11	20-08	• Assembly, 3 Spool Control Valve (See Group 20, Figure 08 for DET)	1
12	85846	• Decal, Agitator	1
13	800917	• Decal, Warning, Keep Hand Out of Hopper and Valve	2
14	86323	• Assembly, Harsh Mix Hopper Agitator (See Group 20, Figure 05 for DET)	1
15	800918	• Decal, Warning, Do Not Stand on Hopper Grate	2
16	86314	• Weldment, Harsh Mix Hopper	1
17	86542	• • Assembly, Clean Out Door (See Group 20, Figure 03 for DET)	1
18	86032	• • Weldment, Harsh Mix Hopper	1
19	800921	• Decal, Warning, Do Not Operate at Pressures Exceeding	1

DASH (-) ITEM NOT ILLUSTRATED

REVISION:



# HOPPER CLEAN OUT DOOR ASSEMBLY (ROUNDED)

**B60**  
**PARTS**  
GROUP 20  
FIGURE 03  
PAGE 01

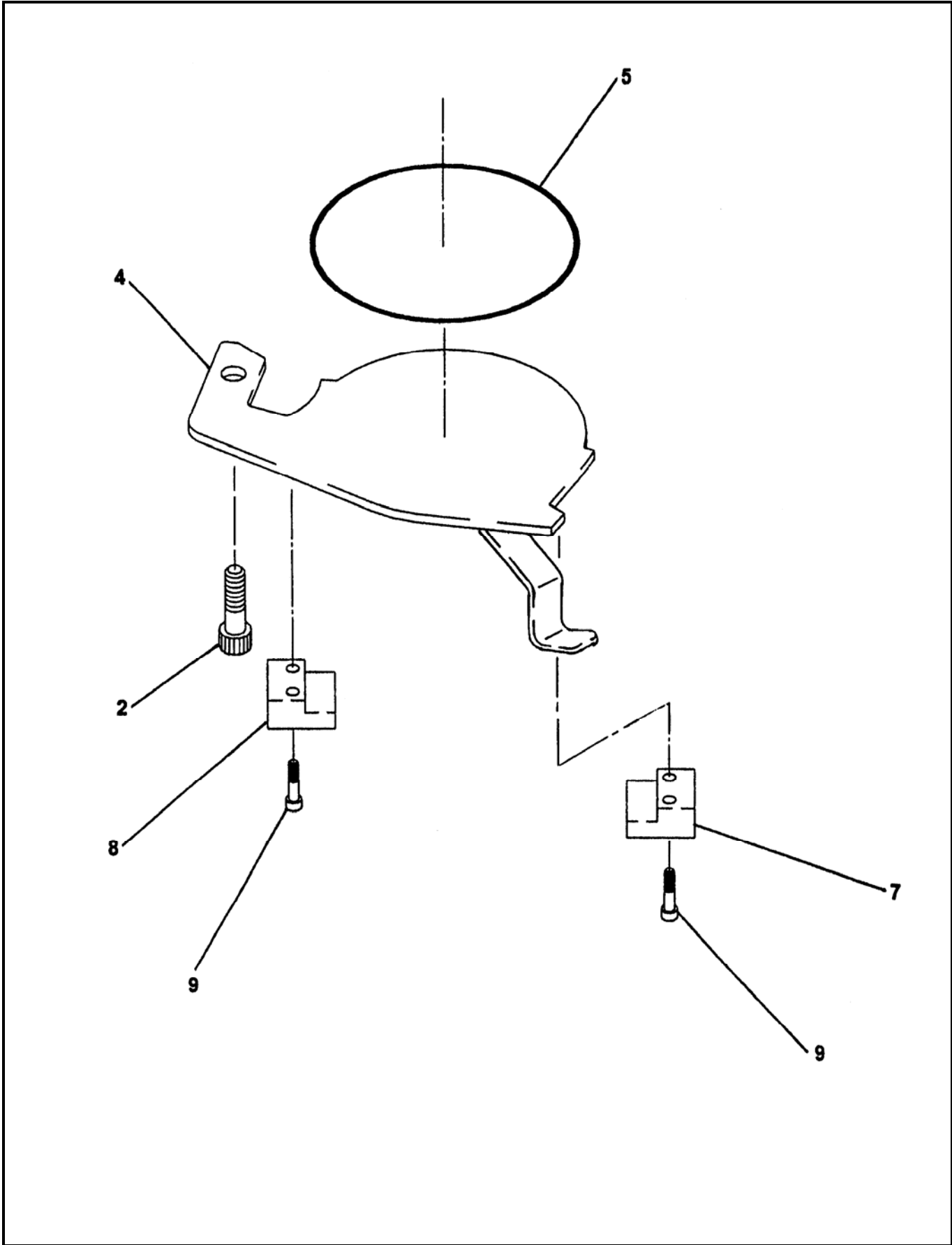

REVISION:



# HOPPER CLEAN OUT DOOR ASSEMBLY (ROUNDED)

**B60**  
**PARTS**  
GROUP 20  
FIGURE 03  
PAGE 02

ITEM NO.	REED'S PARTS NO.	DESCRIPTION	QTY
		1 2 3 4 5	
-1	86542	Assembly, Rounded Clean Out Door (See Group 20, Figure 01 and Figure 02 for NHA )	Ref
2	86922	• Bolt, Shoulder	1
3	-	• OPEN	-
4	86988	• Door, Weldment Clean-Out	1
5	W-102908A	• Cord, Hopper Door O-Ring 2.21 FT	1
6	-	• OPEN	-
7	86560	• Block, RH Clean Out Door	1
8	86559	• Block, LH Clean Out Door	1
9		• Capscrew, Socket Head	4
-10	85312	• Plate, Seal	1
-11	85371	• Neck, Clean Out Door	1

REVISION:



# STANDARD HOPPER AGITATOR ASSEMBLY

**B60**  
**PARTS**  
GROUP 20  
FIGURE 04  
PAGE 01

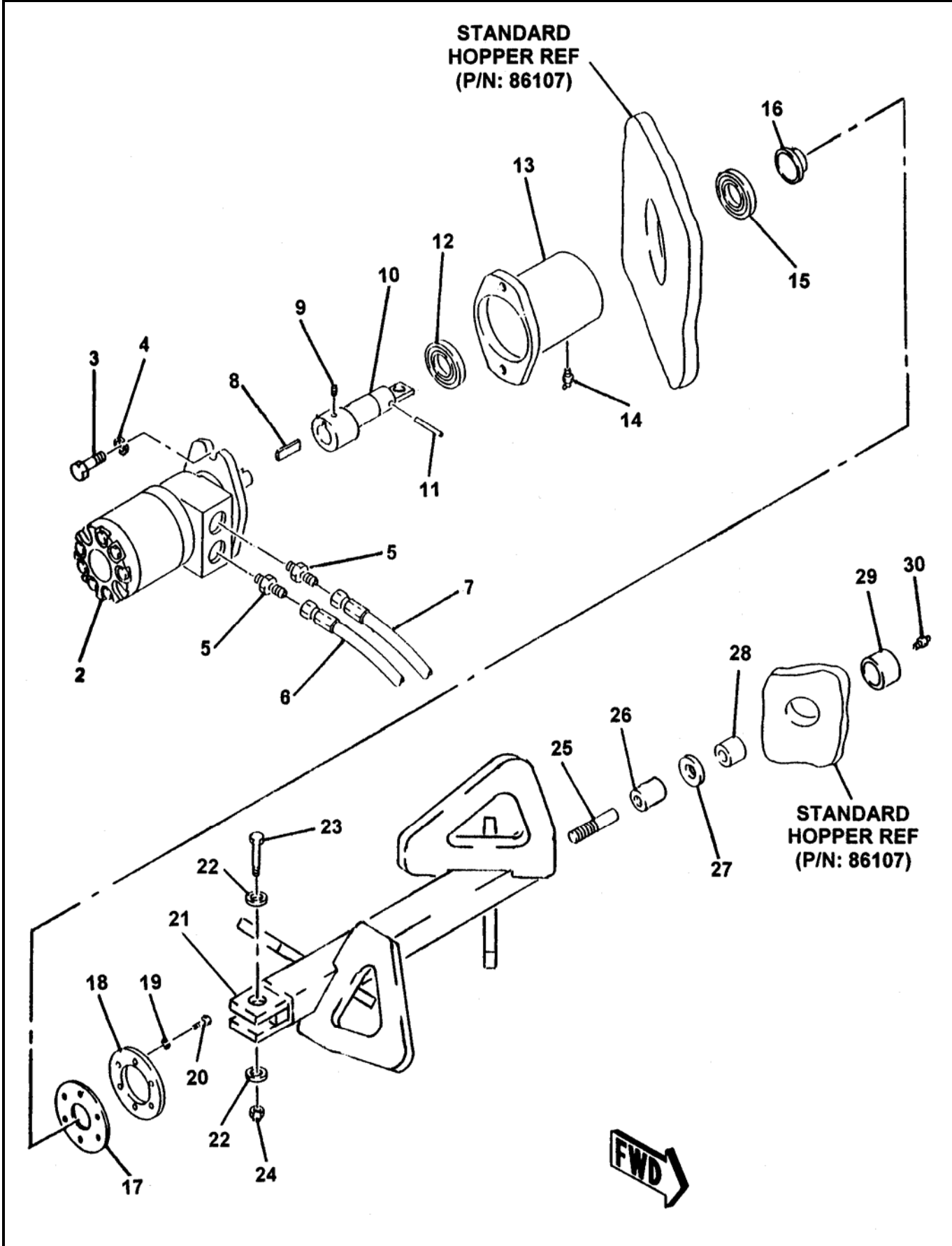

REVISION:



# STANDARD HOPPER AGITATOR ASSEMBLY

**B60**  
**PARTS**  
GROUP 20  
FIGURE 04  
PAGE 02

ITEM NO.	REED'S PARTS NO.	DESCRIPTION	QTY
		1 2 3 4 5	
-1	86322	Assembly, Standard Hopper Agitator (Optional Item) (See Group 20, Figure 01 for NHA)	Ref
2	85811	• Assembly, Standard Hopper Agitator Motor (See Group 20, Figure 06 for DET)	1
3		• Bolt, Hex (attaching parts)	2
4		• Washer, Lock (attaching parts)	2
5		• Fitting, STR	2
6	85658-010	• Assembly, Hose	1
7	85658-011	• Assembly, Hose	1
8	77394	• Key	1
9	80374	• Screw, Set	1
10	85923	• Shaft, Agitator	1
11	80298	• Pin, Spring	1
12	85979	• Bearing, with Seal Ball	1
13	70226	• Housing, Bearing with Flange (Welded on Standard Hopper)	1
14	80516	• Fitting, 90 Grease	1
15	85978	• Bearing, Plain Ball	1
16	85976	• Ring, Agitator Wear	1
17	70212	• Seal	1
18	70211	• Flange, Seal	1
19		• Washer, Lock (attaching parts)	6
20		• Bolt, Hex (attaching parts)	6
21	86330	• Weldment, Standard Hopper Agitator Shaft	1
22		• Washer, Lock (attaching parts)	2
23	80156	• Screw, Hex Head Cap (attaching parts)	1
24	80019	• Nut (attaching parts)	1
25	70214	• Shaft, Idle	1
26	77877	• Spacer	1
27		• Washer	1
28	70219	• Bearing, Idler	1
29	70210	• Housing, Idler Bearing (Welded on Standard Hopper)	1
30		• Fitting, STR Grease	1
33		• Bolt, Hex (attaching parts)	6

DASH (-) ITEM NOT ILLUSTRATED

REVISION:



# HARSH MIX HOPPER AGITATOR ASSEMBLY

**B60**  
**PARTS**  
GROUP 20  
FIGURE 05  
PAGE 01

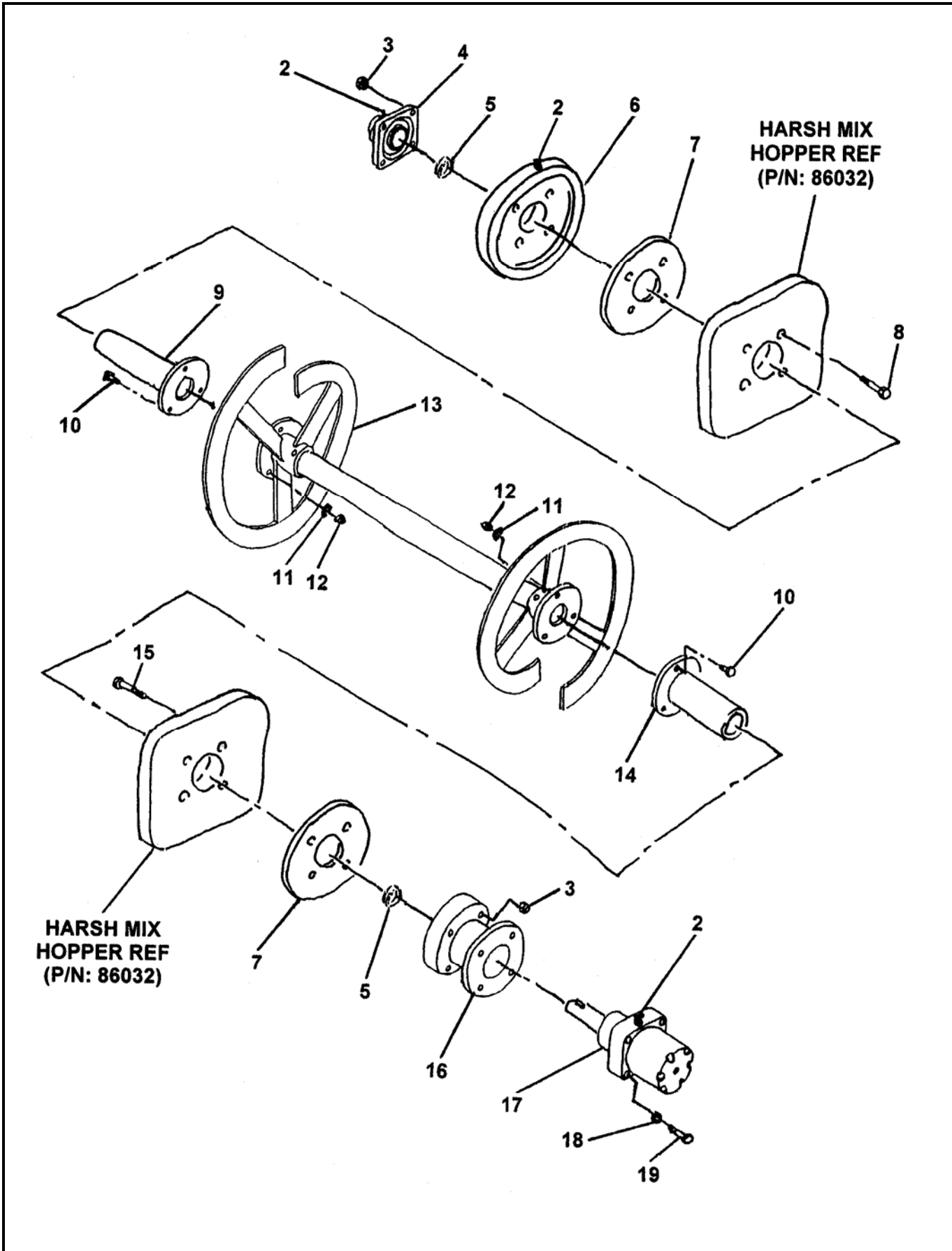

REVISION:





# HARSH MIX HOPPER AGITATOR ASSEMBLY

**B60**  
**PARTS**  
GROUP 20  
FIGURE 05  
PAGE 02

ITEM NO.	REED'S PARTS NO.	DESCRIPTION					QTY
		1	2	3	4	5	
-1	86323	Assembly, Harsh Mix Hopper Agitator (See Group 20, Figure 02 for NHA)					Ref
2		• Fitting, Grease 90					3
3		• Nut, Nylock					8
4	86067	• Bearing, Flange					1
5	86074	• Seal, Poly					2
6	86069	• Flange, Agitator Bearing					2
7	77512	• Seal, Auger (Bearing Side)					2
8		• Bolt, Hex					4
9	86066	• Shaft, Agitator Idler					1
10		• Bolt, Hex					6
11		• Washer, Lock					6
12		• Nut, Hex					6
13	86087	• Eeldment, Agitator Shaft					1
14	86062	• Shaft, Agitator Drive					1
15		• Bolt, Hex					4
16	86070	• Flange, Motor					1
17	85809	• Assembly, Harsh Mix Hopper Agitator Motor (See Group 20, Figure 07 for DET)					1
18		• Washer, Lock (attaching Parts)					4
19		• Bolt, Coarse (attaching Parts)					4

DASH (-) ITEM NOT ILLUSTRATED

REVISION:



# STANDARD HOPPER AGITATOR MOTOR ASSEMBLY

**B60**  
**PARTS**  
GROUP 20  
FIGURE 06  
PAGE 01

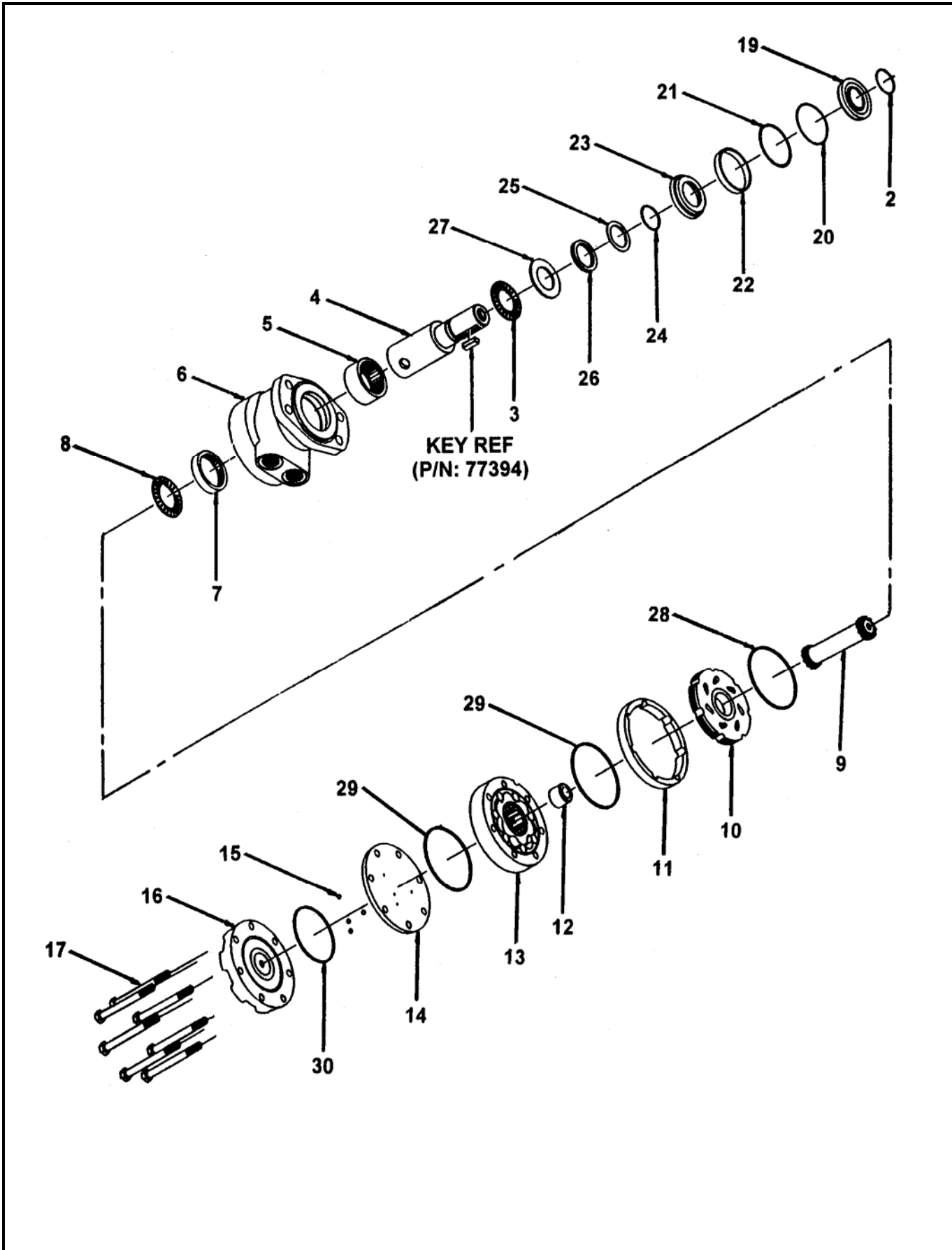

REVISION:



**STANDARD HOPPER  
AGITATOR MOTOR ASSEMBLY**

**B60**  
**PARTS**  
GROUP 20  
FIGURE 06  
PAGE 02

ITEM NO.	REED'S PARTS NO.	DESCRIPTION					QTY
		1	2	3	4	5	
-1	85811	Assembly, Standard Hopper Agitator Motor (See Group 20, Figure 04 for NHA)					Ref
2		• Ring, Wire					1
3		• Bearing, Front Thrust					1
4		• Kit, Shaft					1
5		• Bearing, Front Housing					1
6		• Kit, Housing					1
7		• Bearing, Rear Housing					1
8		• Bearing, Rear Thrust					1
9		• Kit, Drive Link					1
10		• Bearing, Front Thrust					1
11		• Manifold					1
12		• Boot, Manifold					1
13		• Kit, Free Turn Rotor					1
14		• Plate, Balance					1
15		• Ball, Steel					4
16		• Cover, Motor End					1
17		• Bolt, Hex (attaching parts)					7
-18	85809SK	• Kit, Seal					1
19		• • Seal, Dust					1
20		• • Ring, Split Wire					1
21		• • Shim, Metal Back Up					1
22		• • Seal, High Pressure					1
23		• • Carrier, Seal					1
24		• • Shim, Metal Back Up					1
25		• • Seal, Polyamid					1
26		• • Seal, Shaft					1
27		• • Washer, Thrust					1
28		• • Seal, Rear Housing					1
29		• • Seal, Body					2
30		• • Seal, End Cover					1

DASH (-) ITEM NOT ILLUSTRATED

REVISION:



# HARSH MIX HOPPER AGITATOR MOTOR ASSEMBLY

**B60**  
**PARTS**  
GROUP 20  
FIGURE 07  
PAGE 01

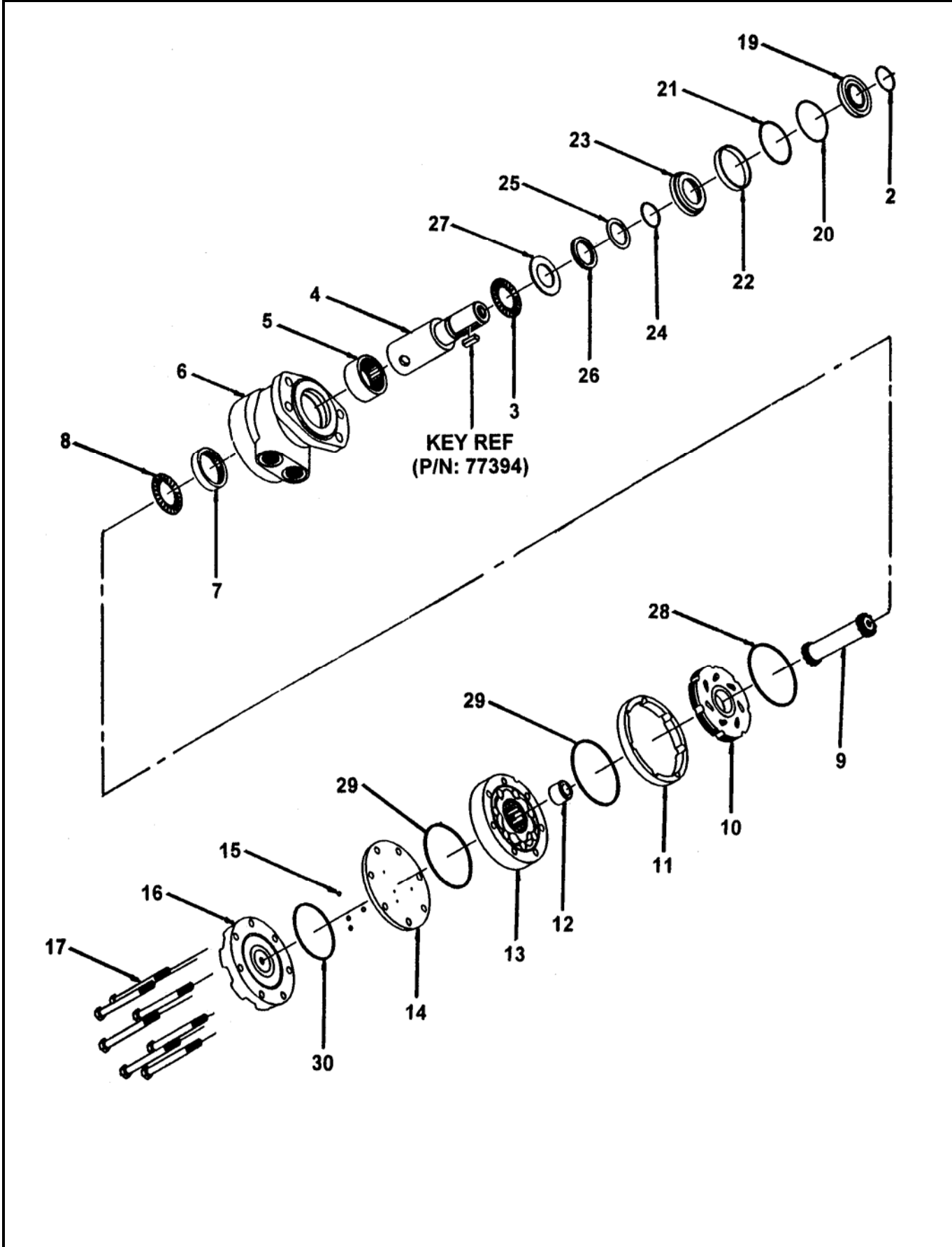

REVISION:



# HARSH MIX HOPPER AGITATOR MOTOR ASSEMBLY

**B60**  
**PARTS**  
GROUP 20  
FIGURE 07  
PAGE 02

ITEM NO.	REED'S PARTS NO.	DESCRIPTION					QTY
		1	2	3	4	5	
-1	85809	Assembly, Harsh Mix Hopper Agitator Motor (See Group 20, Figure 05 for NHA)					Ref
2		• Ring, Wire					1
3		• Bearing, Front Thrust					1
4		• Kit, Shaft					1
5		• Bearing, Front Housing					1
6		• Kit, Housing					1
7		• Bearing, Rear Housing					1
8		• Bearing, Rear Thrust					1
9		• Kit, Drive Link					1
10		• Bearing, Front Thrust					1
11		• Manifold					1
12		• Boot, Manifold					1
13		• Kit, Free Turn Rotor					1
14		• Plate, Balance					1
15		• Ball, Steel					4
16		• Cover, Motor End					1
17		• Bolt, Hex (attaching parts)					7
-18	85809SK	• Kit, Seal					1
19		• • Seal, Dust					1
20		• • Ring, Split Wire					1
21		• • Shim, Metal Back Up					1
22		• • Seal, High Pressure					1
23		• • Carrier, Seal					1
24		• • Shim, Metal Back Up					1
25		• • Seal, Polyamid					1
26		• • Seal, Shaft					1
27		• • Washer, Thrust					1
28		• • Seal, Rear Housing					1
29		• • Seal, Body					2
30		• • Seal, End Cover					1

DASH (-) ITEM NOT ILLUSTRATED



# 3 SPOOL CONTROL VALVE ASSEMBLY

**B60**  
**PARTS**  
GROUP 20  
FIGURE 08  
PAGE 01

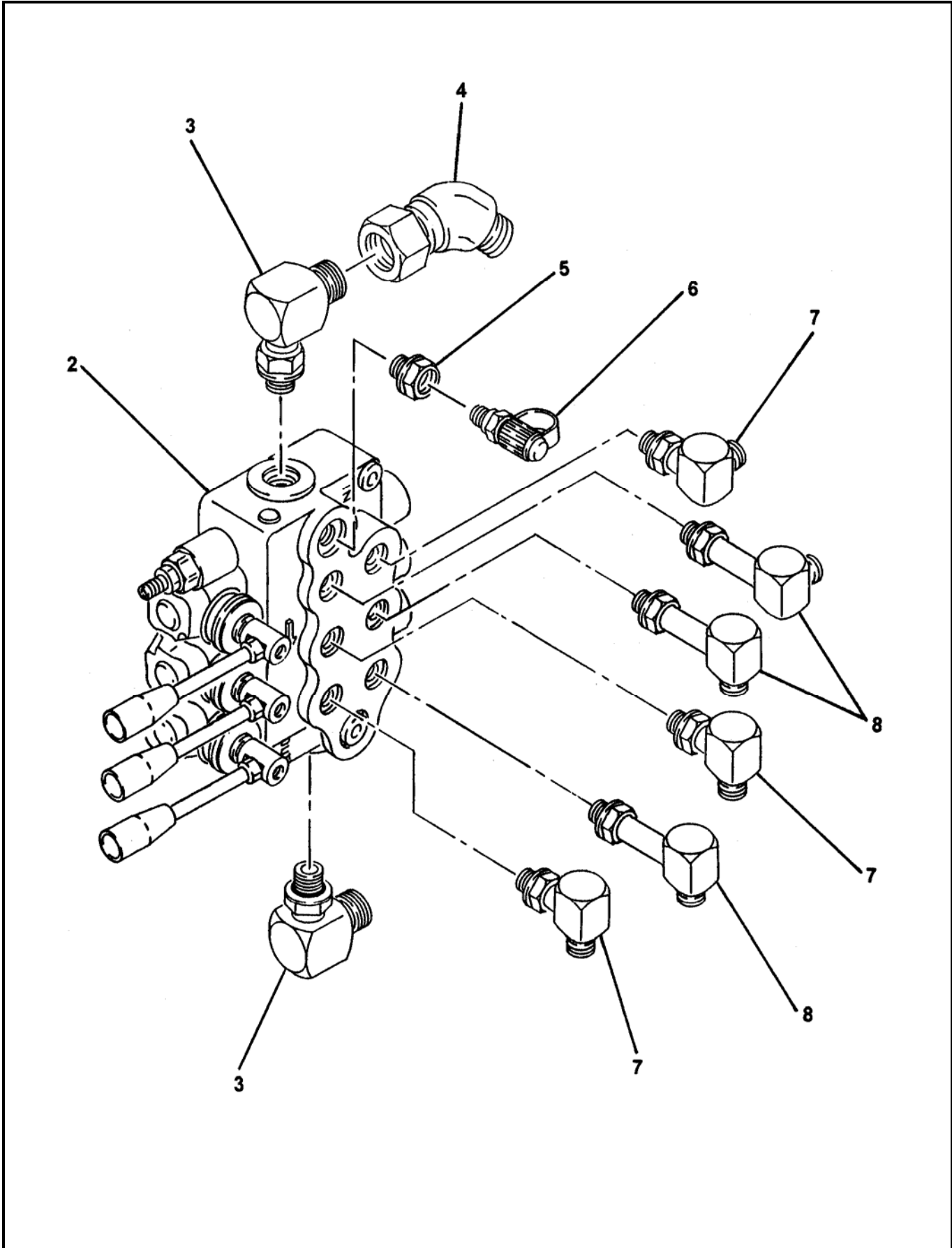

REVISION:



# 3 SPOOL CONTROL VALVE ASSEMBLY

**B60**  
**PARTS**  
GROUP 20  
FIGURE 08  
PAGE 02

ITEM NO.	REED'S PARTS NO.	DESCRIPTION	QTY
		1 2 3 4 5	
-1	20-08	Assembly, 3 Spool Control Valve (See Group 20, Figure 01 and Figure 02 for NHA)	Ref
2	74471	• Sub-Assembly, Agitator Control Valve (See Group 20, Figure 10 for DET)	1
3		• Fitting, 90	2
4		• Swivel, 45	1
5		• Reducer, 8-6	1
6	800083	• Fitting, Mini Check (Port)	1
7		• Fitting, 90	3
8		• Fitting, 90	3
-9		• Bolt, Hex	2
-10		• Washer, SPL Lock	2

DASH (-) ITEM NOT ILLUSTRATED

REVISION:



# 3 SPOOL CONTROL VALVE SUB-ASSEMBLY

**B60**  
**PARTS**  
GROUP 20  
FIGURE 09  
PAGE 01

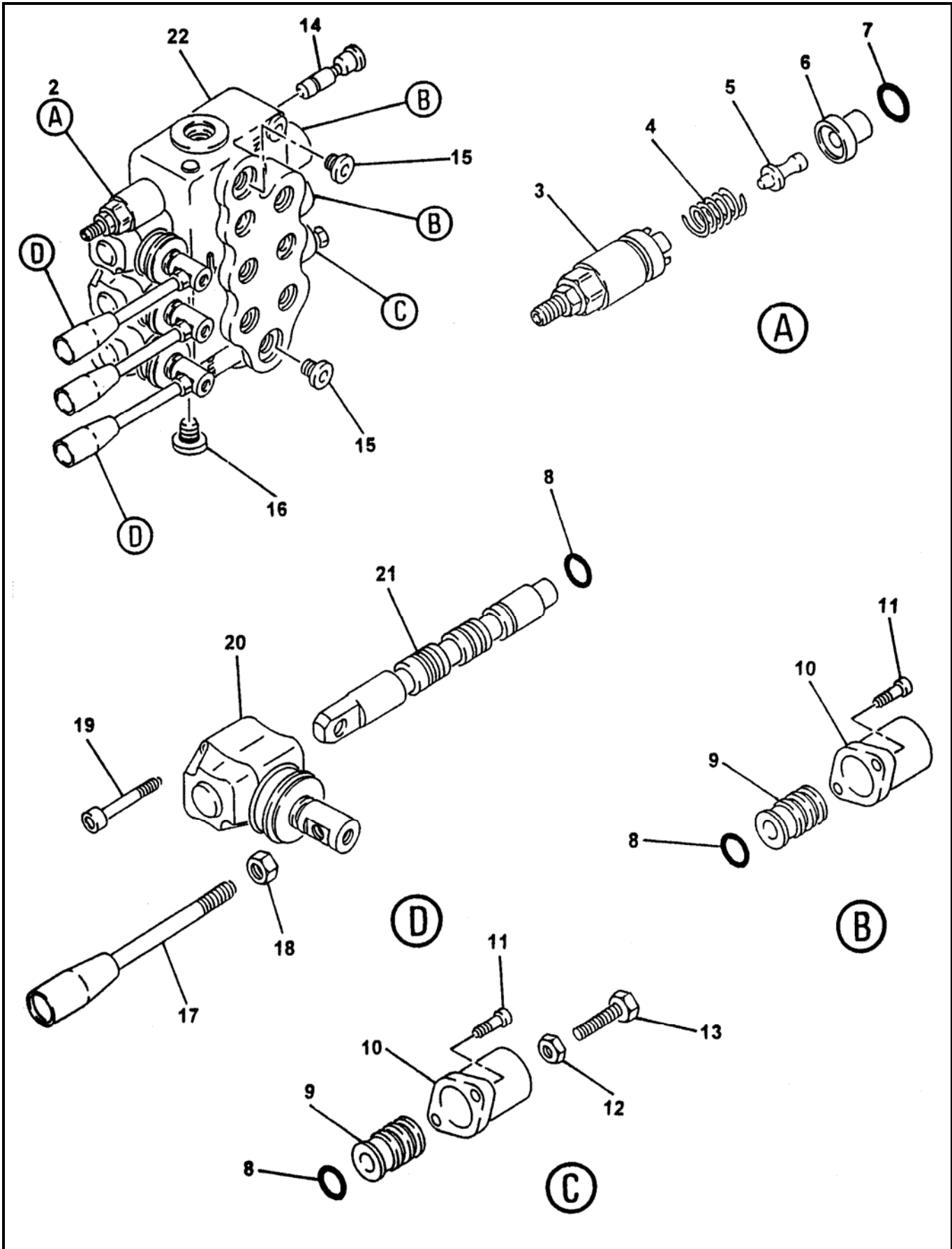

REVISION:





### 3 SPOOL CONTROL VALVE SUB-ASSEMBLY

**B60**  
**PARTS**  
GROUP 20  
FIGURE 09  
PAGE 02

ITEM NO.	REED'S PARTS NO.	DESCRIPTION					QTY
		1	2	3	4	5	
-1	74471	Sub-Assembly, 3 Spool Control Valve (See Group 20, Figure 08 for NHA)					Ref
2	85706	• Cartridge, Relief					1
3		• • Kit, Screw					1
4		• • Spring					1
5		• • Pin, Screw Kit					1
6		• • Ring					1
7		• • O-Ring					1
8		• O-Ring					4
9		• Kit, Spool Control					3
10		• Cap, Spool					3
11		• Screw, SOC (attaching Parts)					6
12		• Nut					1
13		• Bolt, Hex					1
14		• Kit, VRS					1
15		• Plug					2
16		• Plug					1
17		• Handle, Remixer Valve					3
18		• Nut (attaching parts)					3
19		• Screw, SOC					6
20		• Lever, L					3
21		• Spool					3
22		• Body, Valve					1

DASH (-) ITEM NOT ILLUSTRATED

REVISION:

**REED**

**TRAILER MOUNTED PUMP MODEL *B60*  
ILLUSTRATED PARTS MANUAL**

***B60***  
**PARTS**  
GROUP 20  
FIGURE 10  
PAGE 01

THIS PAGE INTENTIONALLY LEFT BLANK.

REVISION:

**REED TRAILER MOUNTED CONCRETE PUMP 01 MODEL B60 ILLUSTRATED PARTS MANUAL GROUP 30 HYDRAULIC TANK INSTALLATION CONTAINS THE FOLLOWING FIGURES:**

- FIGURE 00** TABLE OF CONTENTS
- FIGURE 01** TANK INSTALLATION
- FIGURE 02** HYDRAULIC TANK ASSEMBLY
- FIGURE 03** SWING TUBE CIRCUIT MANIFOLD ASSEMBLY
- FIGURE 04** SWING TUBE CIRCUIT MAIN SOLENOID VALVE ASSEMBLY
- FIGURE 05** SWING TUBE CIRCUIT PILOT SOLENOID VALVE ASSEMBLY
- FIGURE 06** BALL VALVE ASSEMBLY
- FIGURE 07** DRIVE CYLINDER CIRCUIT MANIFOLD ASSEMBLY
- FIGURE 08** DRIVE CYLINDER CIRCUIT MAIN SOLENOID VALVE ASSEMBLY
- FIGURE 09** DRIVE CYLINDER CIRCUIT PILOT SOLENOID VALVE ASSEMBLY
- FIGURE 10** ACCUMULATOR ASSEMBLY
- FIGURE 11** ACCUMULATOR BLADDER REPAIR KIT

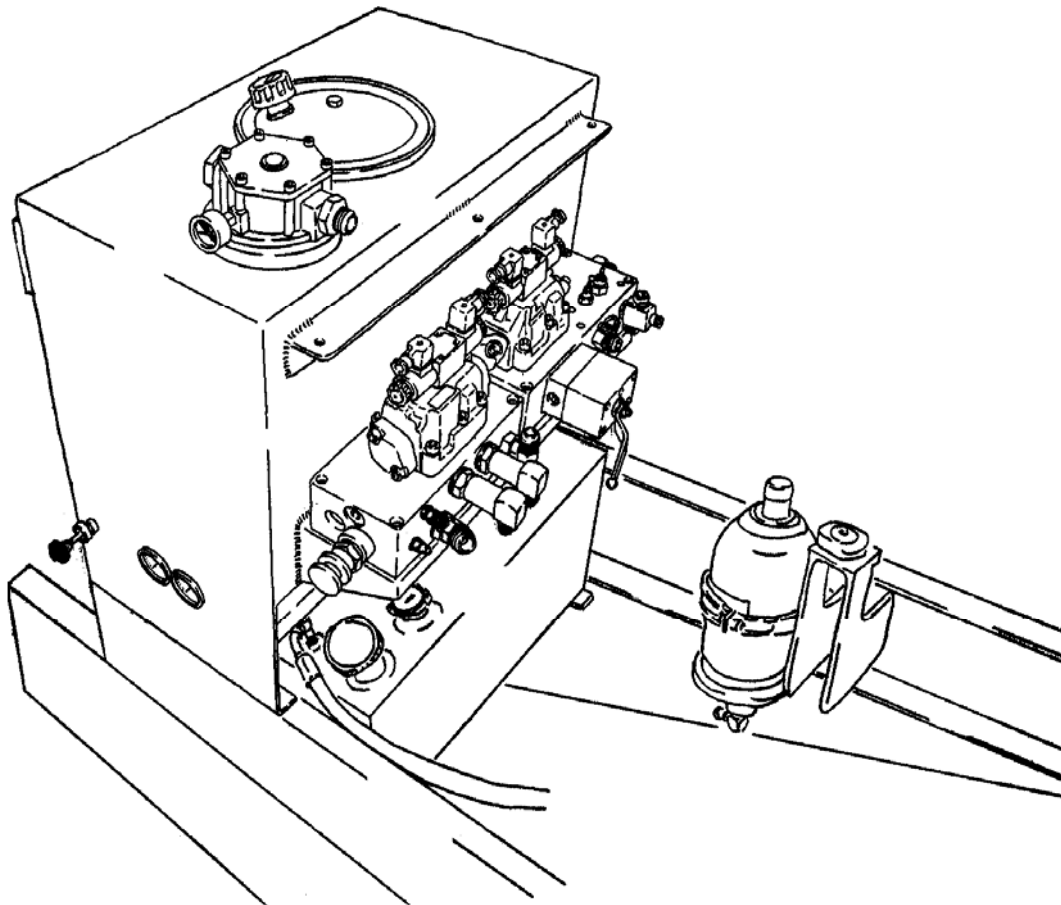

## TANK INSTALLATION

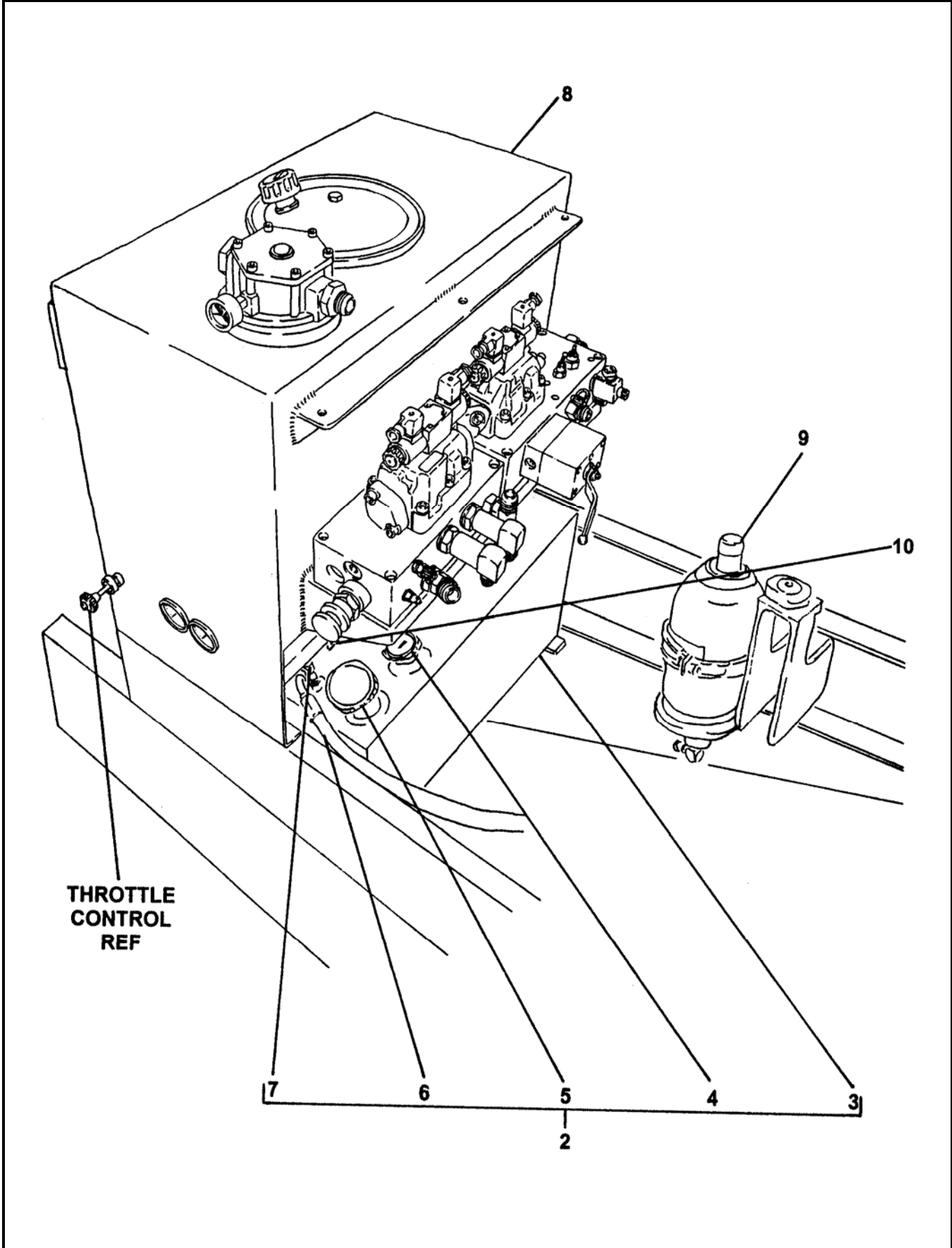



# TANK INSTALLATION

**B60**  
**PARTS**  
GROUP 30  
FIGURE 01  
PAGE 02

ITEM NO.	REED'S PARTS NO.	DESCRIPTION	QTY
		1 2 3 4 5	
-1	30-01	Installation, Tank (See Group 10, Figure 01, 02, 03 and 04 for NHA)	Ref
2	85363	• Assembly, Fuel Tank	1
3	85111	• • Weldment, Fuel Tank	1
4	85569	• • Gauge, Fuel	1
5	85570	• • Cap, Fuel	1
6	85362	• • Assembly, Fuel Pick Up Tube	2
7		• • Elbow, 90	2
8	85361	• Assembly, Hydraulic Tank (See Group 30, Figure 02 for DET)	1
9	30-10	• Assembly, Accumulator (See Group 30, Figure 10 for DET)	1
10	85815	• Valve, Solenoid	1
-11	85701	• • Cartridge, Solenoid Valve	1
-12	85702	• • Coil, 12 VDC	1
-13	74716	• Hose, 6 Feet Fuel	1
-14	10577	• Clamp, Fuel Hose	2
-15	86365	• Kit, Hose (See SCHEMATIC Section, Page 05 for DET)	1

DASH (-) ITEM NOT ILLUSTRATED



# HYDRAULIC TANK ASSEMBLY

**B60**  
**PARTS**  
GROUP 30  
FIGURE 02  
PAGE 01

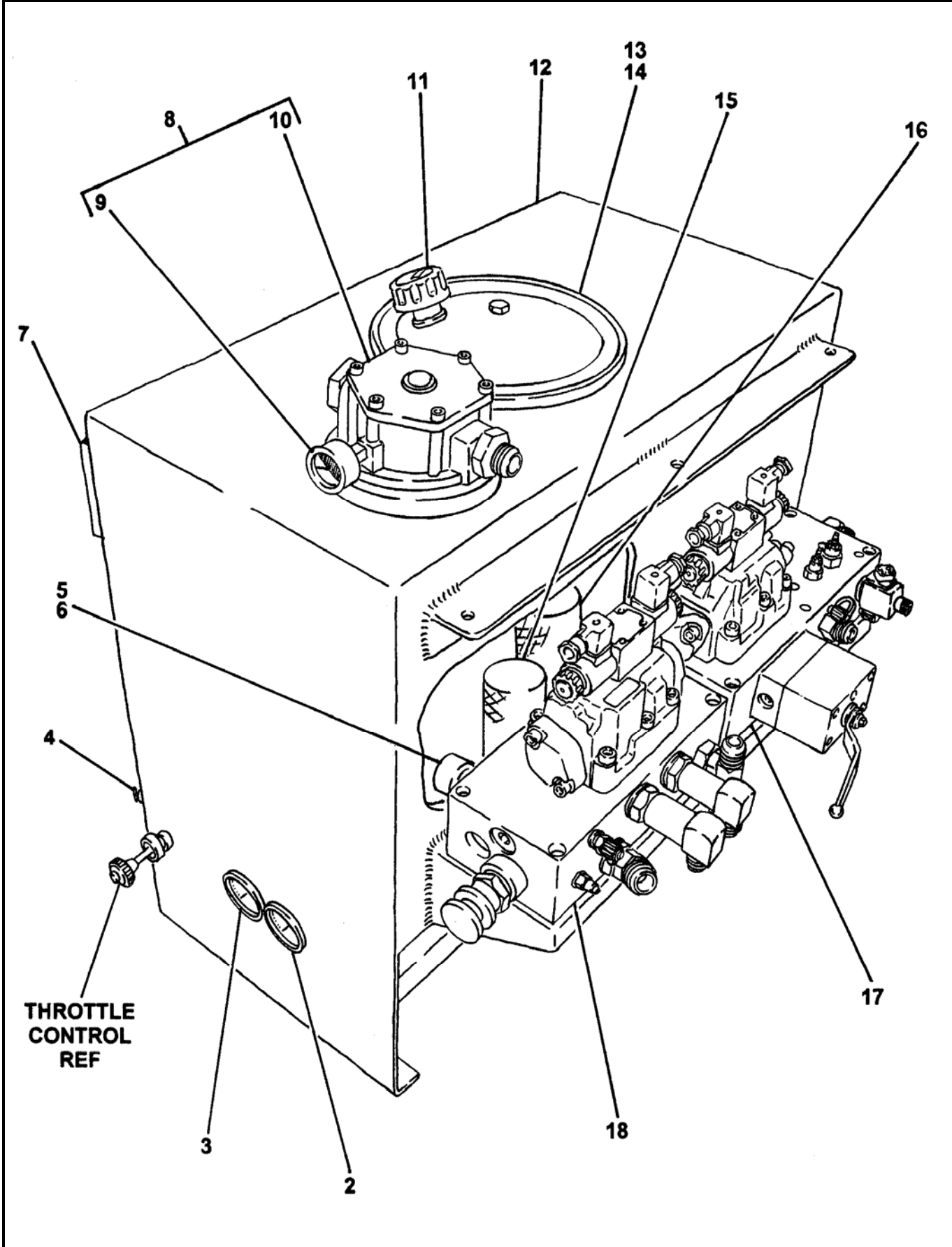

REVISION:



# HYDRAULIC TANK ASSEMBLY

**B60**  
**PARTS**  
GROUP 30  
FIGURE 02  
PAGE 02

ITEM NO.	REED'S PARTS NO.	DESCRIPTION	QTY
		1 2 3 4 5	
-1	85361	Assembly, Hydraulic Tank (See Group 30, Figure 01 for NHA)	Ref
2	70366	• Gauge, 3,000 PSI Hydraulic	1
3	74562	• Gauge, 6,000 PSI Hydraulic	1
4	801025	• Cock, Drain	1
5	85574	• Valve, 2 Inch Check	1
6	10981	• Nipple, 2 Inch	1
7	74509	• Gauge, Sight	1
8	85282	• Filter, Return	1
9	85575	• • Gauge, Return Filter	1
10	85283	• • Element, Return Filter	1
11	85537	• Filler, Breather	1
12	85102	• Weldment, Hydraulic Tank	1
13	85824	• • End Cover, Hydraulic Tank	1
14	85867	• • Gasket, End Cover	1
15	79247	• Separator, Magnetic	1
16	800230	• Separator, Magnetic	1
17	85249	• Assembly, Swing Tube Circuit Manifold (See Group 30, Figure 03 for DET)	1
18	85248	• Assembly, Drive Cylinder Circuit Manifold (See Group 30, Figure 07 for DET)	1
-19	78598	• Plug, Hoffman	A/R

DASH (-) ITEM NOT ILLUSTRATED







# SWING TUBE CIRCUIT MANIFOLD ASSEMBLY

**B60**  
**PARTS**  
GROUP 30  
FIGURE 03  
PAGE 02

ITEM NO.	REED'S PARTS NO.	DESCRIPTION	QTY
		1 2 3 4 5	
-1	85249	Assembly, Swing Tube Circuit Manifold (See Group 30, Figure 02 for NHA)	Ref
2	85693	• Assembly, Swing Tube Circuit Solenoid Valve	1
3	85694	• • Assembly, Swing Tube Circuit Main Solenoid Valve (See Group 30, Figure 04 for DET)	1
4	85695	• • Assembly, Swing Tube Circuit Pilot Solenoid Valve (See Group 30, Figure 05 for DET)	1
5	85704	• Cartridge, Unloader Valve	1
-5A	85704SK	• • Kit, Unloader Valve Cartridge Seal	1
6	85703	• Cartridge, Relief Valve	1
-6A	85703SK	• • Kit, Relief Valve Cartridge Seal	1
7		• Body, Swing Tube Circuit Manifold	1
8		• Elbow, 90	2
9	78593	• Port, Mini Check	2
10	85701	• Cartridge, SV4 Solenoid Valve	1
11	85702	• • Coil, SV4 Solenoid Valve Cartridge	1
12		• Fitting, STR	1
13		• Fitting, STR	1
14	85699	• Cartridge, SV3 Solenoid Valve	1
15	85700	• • Coil, SV3 Solenoid Valve Cartridge	1
16	85705	• Assembly, Ball Valve (See Group 30, Figure 06 for DET)	1

DASH (-) ITEM NOT ILLUSTRATED

REVISION:



# SWING TUBE CIRCUIT MAIN SOLENOID VALVE ASSEMBLY

**B60**  
**PARTS**  
GROUP 30  
FIGURE 04  
PAGE 01

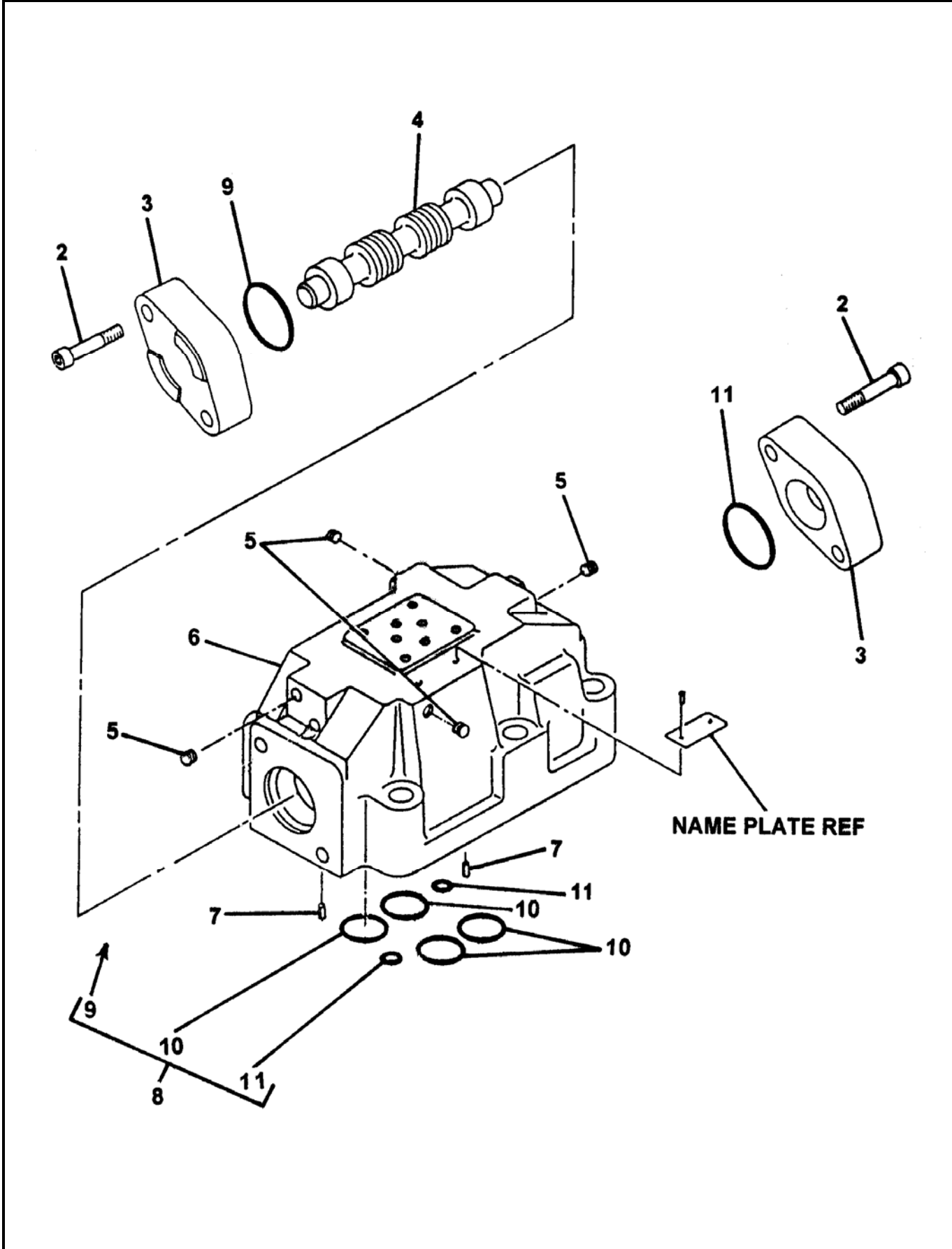

REVISION:



**SWING TUBE CIRCUIT  
MAIN SOLENOID VALVE ASSEMBLY**

**B60**  
**PARTS**  
GROUP 30  
FIGURE 04  
PAGE 02

ITEM NO.	REED'S PARTS NO.	DESCRIPTION	QTY
		1 2 3 4 5	
-1	85694	Assembly, Swing Tube Circuit Main Solenoid Valve (See Group 30, Figure 03 for NHA)	Ref
2		• Screw, SOC	4
3		• Cover	2
4		• Spool	1
5		• Plug	4
6		• Housing, Cartridge	1
7		• Pin, Grooved	2
8	74994	• Kit, Seal	1
9		• • O-Ring	2
10		• • O-Ring	4
11		• • O-Ring	2

DASH (-) ITEM NOT ILLUSTRATED



# SWING TUBE CIRCUIT PILOT SOLENOID VALVE ASSEMBLY

**B60**  
**PARTS**  
GROUP 30  
FIGURE 05  
PAGE 01

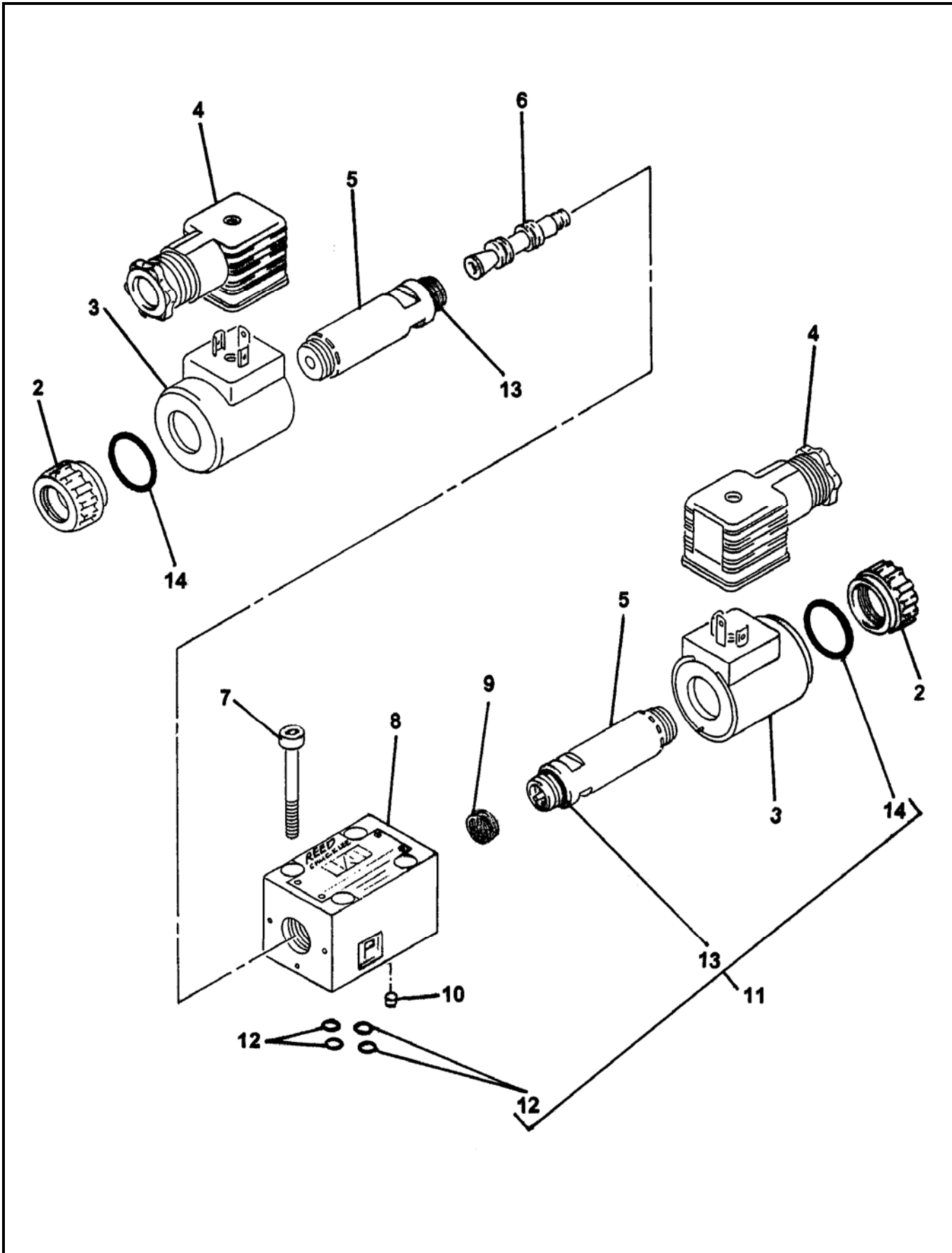

REVISION:



# SWING TUBE CIRCUIT PILOT SOLENOID VALVE ASSEMBLY

**B60**  
**PARTS**  
GROUP 30  
FIGURE 05  
PAGE 02

ITEM NO.	REED'S PARTS NO.	DESCRIPTION					QTY
		1	2	3	4	5	
-1	85695	Assembly, Swing Tube Circuit Pilot Solenoid Valve (See Group 30, Figure 03 for NHA)					Ref
2		• Cap, Coil					2
3	85692	• Coil, Solenoid					2
4	74597	• Connector, Plug					2
5		• Amature					2
6		• Spool					1
7		• Screw, SOC					4
8		• Housing, Solenoid Valve					1
9		• Detent					1
10		• Orifice					1
11	72313	• Kit, O-Ring					1
12		• • O-Ring					4
13		• • O-Ring					2
14		• • O-Ring					2

DASH (-) ITEM NOT ILLUSTRATED

REVISION:



# BALL VALVE ASSEMBLY

**B60**  
**PARTS**  
GROUP 30  
FIGURE 06  
PAGE 01

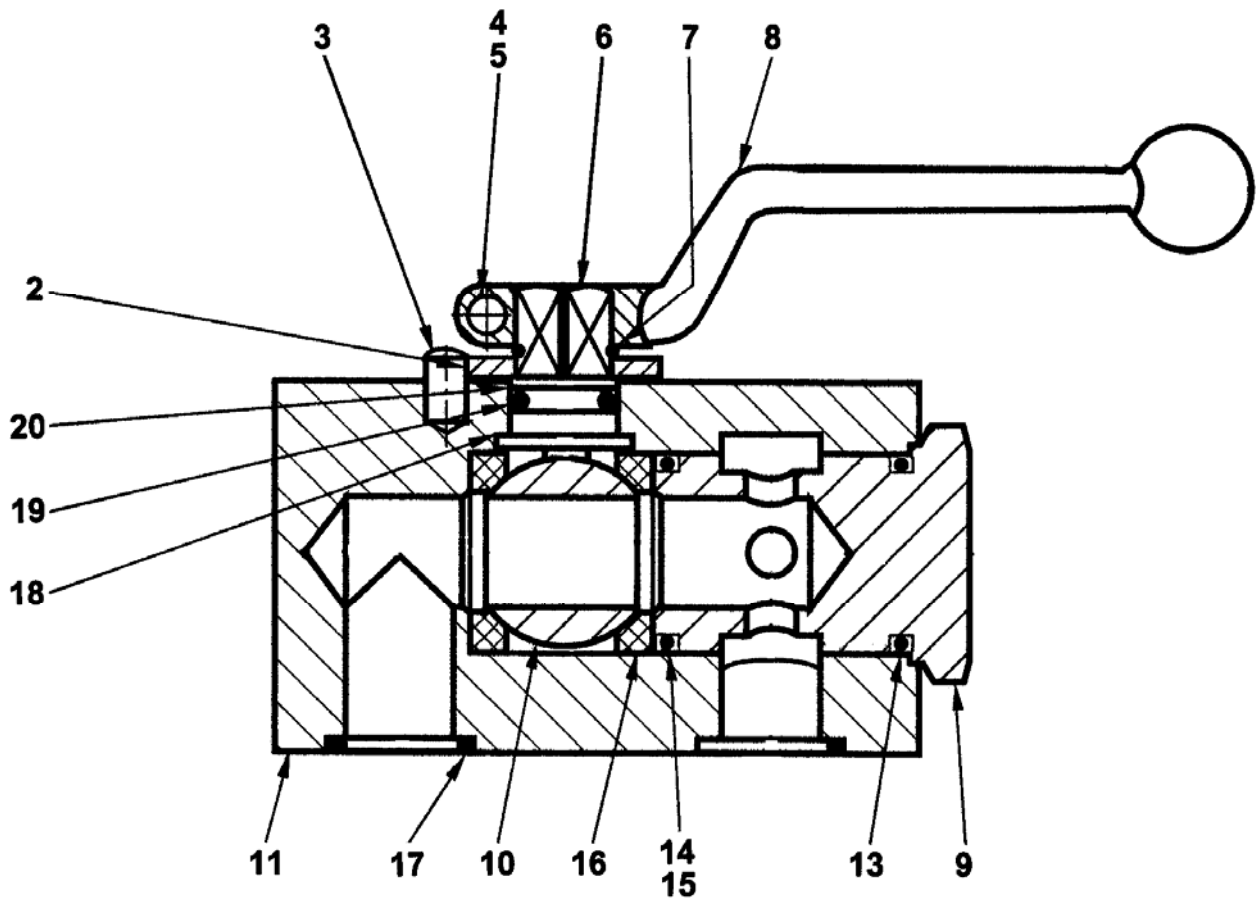

REVISION:



# BALL VALVE ASSEMBLY

**B60**  
**PARTS**  
GROUP 30  
FIGURE 06  
PAGE 02

ITEM NO.	REED'S PARTS NO.	DESCRIPTION					QTY
		1	2	3	4	5	
-1	85705	Assembly, Ball Valve (See Group 30, Figure 03 for NHA)					Ref
2					• Washer, Limit	1	
3					• Pin, Stop	1	
4					• Bolt, Hex	1	
5					• Nut, Hex	1	
6					• Handle, Control	1	
7					• Spindle, Control	1	
8					• Retainer, Spring	1	
9					• Plug	1	
10					• Ball	1	
11					• Housing	1	
-12					• Kit, Seal	1	
13					• • O-Ring	1	
14					• • O-Ring	1	
15					• • Ring, Back Up	1	
16					• • Seal, Bowl	2	
17					• • O-Ring	1	
18					• • Washer, Thrust	1	
19					• • O-Ring	1	
20					• • Ring, Back Up	1	

DASH (-) ITEM NOT ILLUSTRATED



# DRIVE CYLINDER CIRCUIT MANIFOLD ASSEMBLY

**B60**  
**PARTS**  
GROUP 30  
FIGURE 07  
PAGE 01

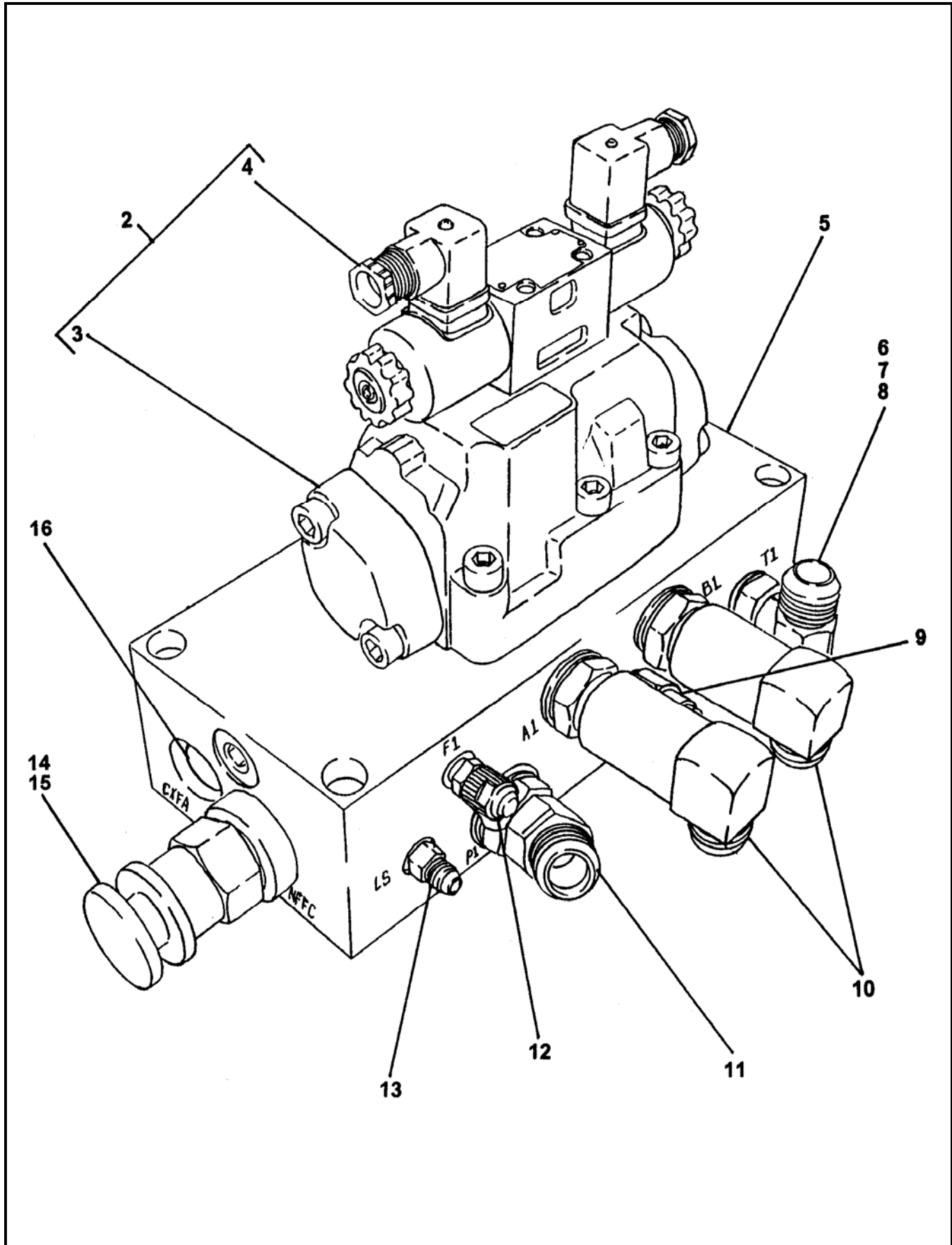

REVISION:





# DRIVE CYLINDER CIRCUIT MANIFOLD ASSEMBLY

**B60**  
**PARTS**  
GROUP 30  
FIGURE 07  
PAGE 02

ITEM NO.	REED'S PARTS NO.	DESCRIPTION	QTY
		1 2 3 4 5	
-1	85248	Assembly, Drive Cylinder Circuit Manifold (See Group 30, Figure 02 for NHA)	Ref
2	85689	• Assembly, Drive Cylinder Circuit Solenoid Valve	1
3	85690	• • Assembly, Drive Cylinder Circuit Main Solenoid Valve (See Group 30, Figure 08 for DET)	1
4	85691	• • Assembly, Drive Cylinder Circuit Pilot Solenoid Valve (See Group 30, Figure 09 for DET)	1
5		• Body, Drive Cylinder Circuit Manifold	1
6		• Tee	1
7		• Reducer	1
8		• Plug	1
9	85696	• Cartridge, Relief Valve	1
10		• Elbow, 90	2
11		• Elbow, 45	1
12	78593	• Port, Mini Check	1
13		• Fitting, STR	1
14	85697	• Cartridge, Flow Control Valve	1
15	85697SK	• • Kit, Flow Control Valve Cartridge Seal	1
16	85698	• Cartridge, Check Valve	1

DASH (-) ITEM NOT ILLUSTRATED



# DRIVE CYLINDER CIRCUIT MAIN SOLENOID VALVE ASSEMBLY

**B60**  
**PARTS**  
GROUP 30  
FIGURE 08  
PAGE 01

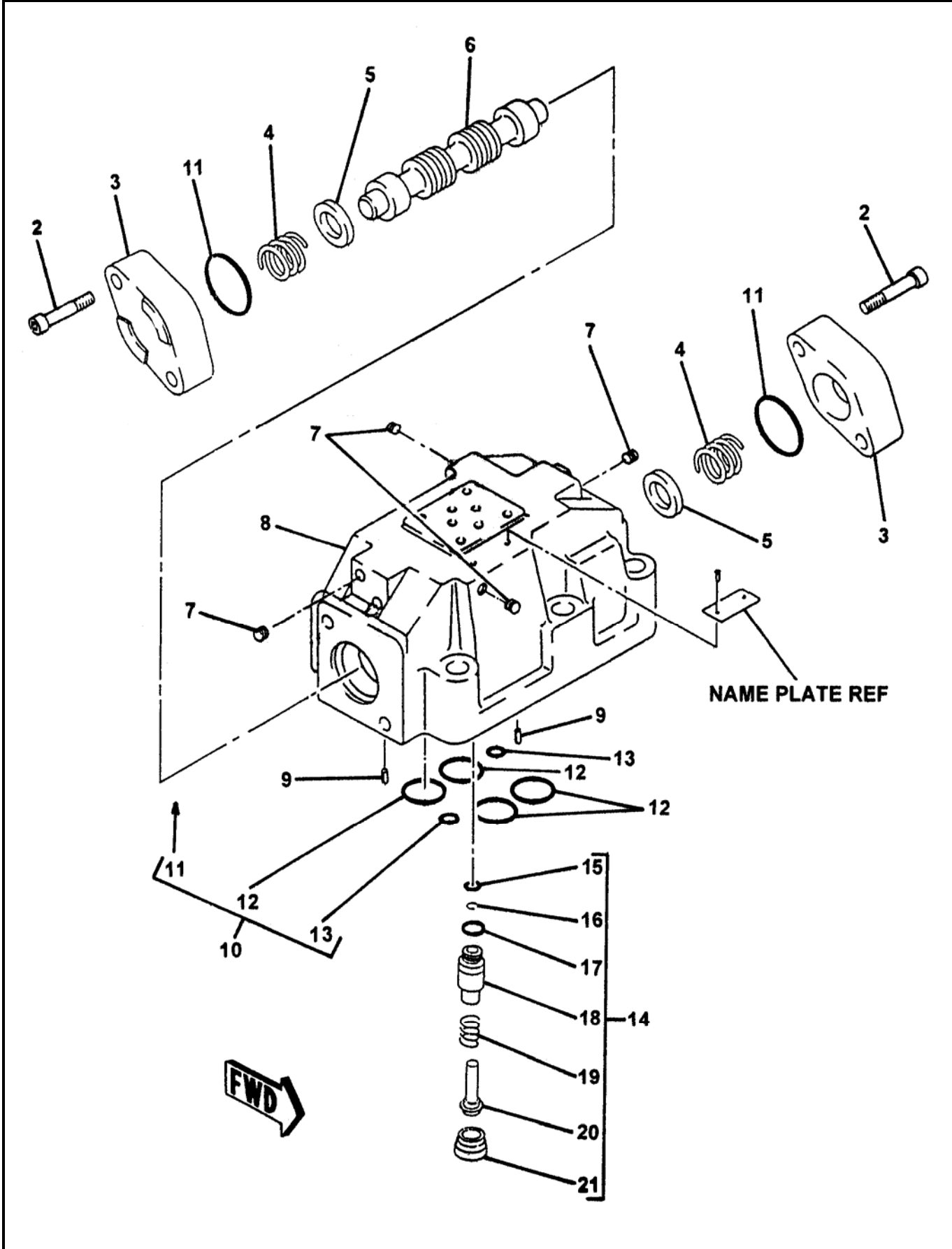

REVISION:



**DRIVE CYLINDER CIRCUIT  
MAIN SOLENOID VALVE ASSEMBLY**

**B60**  
**PARTS**  
GROUP 30  
FIGURE 08  
PAGE 02

ITEM NO.	REED'S PARTS NO.	DESCRIPTION					QTY
		1	2	3	4	5	
-1	85690	Assembly, Drive Cylinder Circuit Main Solenoid Valve (See Group 30, Figure 07 for NHA)					Ref
2		• Screw, SOC					4
3		• Cover					2
4		• Spring, Compression					2
5		• Plate, Spring					2
6		• Spool					1
7		• Plug					4
8		• Housing, Cartridge					1
9		• Pin, Grooved					2
10	74994	• Kit, Seal					1
11		• • O-Ring					2
12		• • O-Ring					4
13		• • O-Ring					2
14	73147	• Sub-Assembly, Pilot Pressure Valve					1
15		• • O-Ring					1
16		• • Circlip					1
17		• • O-Ring					1
18		• • Sleeve					1
19		• • Spring, Compression					1
20		• • Cone					1
21		• • Valve, Seat					1

DASH (-) ITEM NOT ILLUSTRATED



# DRIVE CYLINDER CIRCUIT PILOT SOLENOID VALVE ASSEMBLY

**B60**  
**PARTS**  
GROUP 30  
FIGURE 09  
PAGE 01

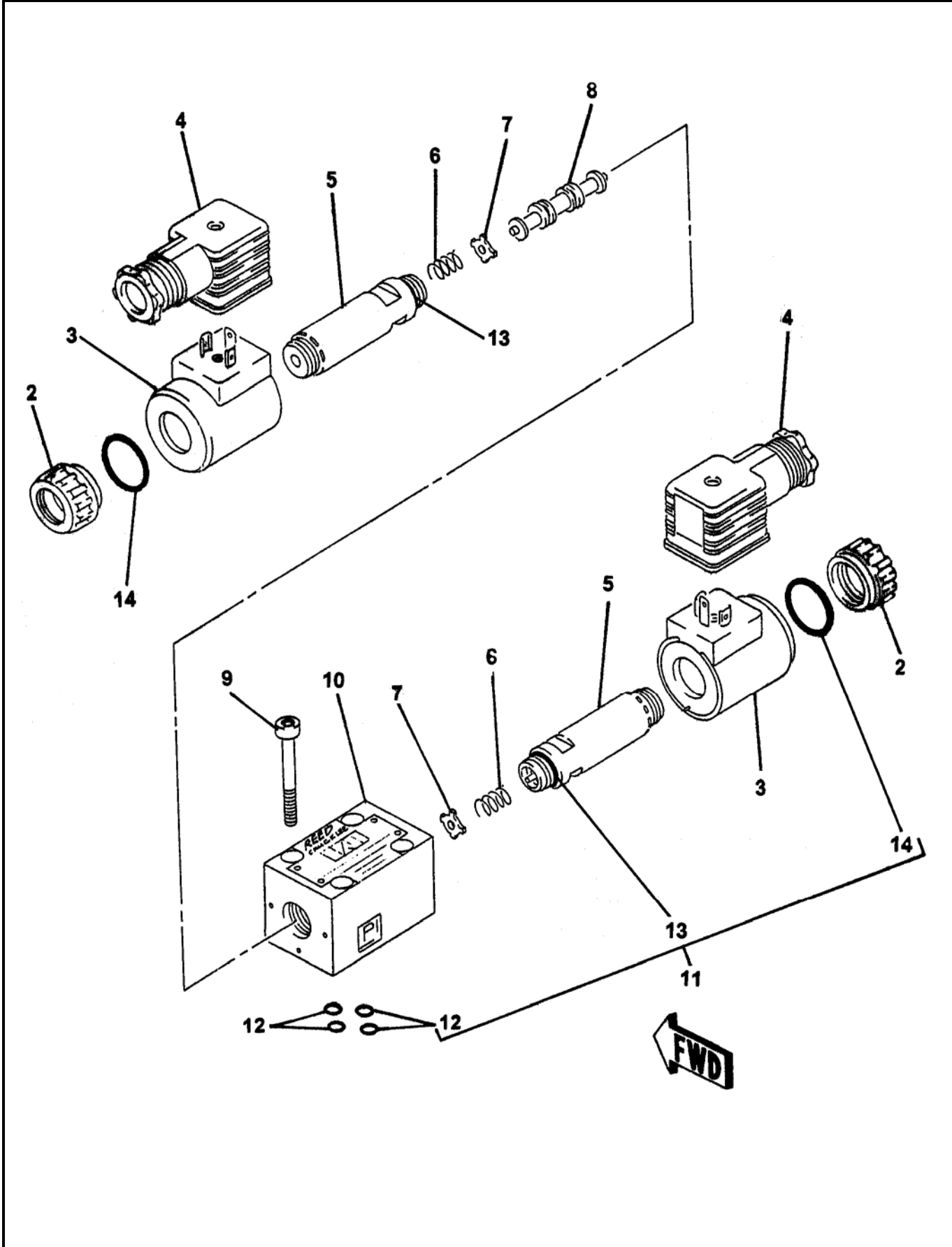

REVISION:



# SWING TUBE CIRCUIT PILOT SOLENOID VALVE ASSEMBLY

**B60**  
**PARTS**  
GROUP 30  
FIGURE 09  
PAGE 02

ITEM NO.	REED'S PARTS NO.	DESCRIPTION	QTY
		1 2 3 4 5	
-1	85691	Assembly, Drive Cylinder Circuit Pilot Solenoid Valve (See Group 30, Figure 07 for NHA)	Ref
2		• Cap, Coil	2
3	85692	• Coil, Drive Cylinder Circuit Main Solenoid	2
4	74597	• Connector, Plug	2
5		• Amature	2
6		• Spring	2
7		• Plate, Spring	2
8		• Spool	1
9		• Screw, SOC	4
10		• Housing, Solenoid Valve	1
11	72313	• Kit, O-Ring	1
12		• • O-Ring	4
13		• • O-Ring	2
14		• • O-Ring	2

DASH (-) ITEM NOT ILLUSTRATED

## ACCUMULATOR ASSEMBLY

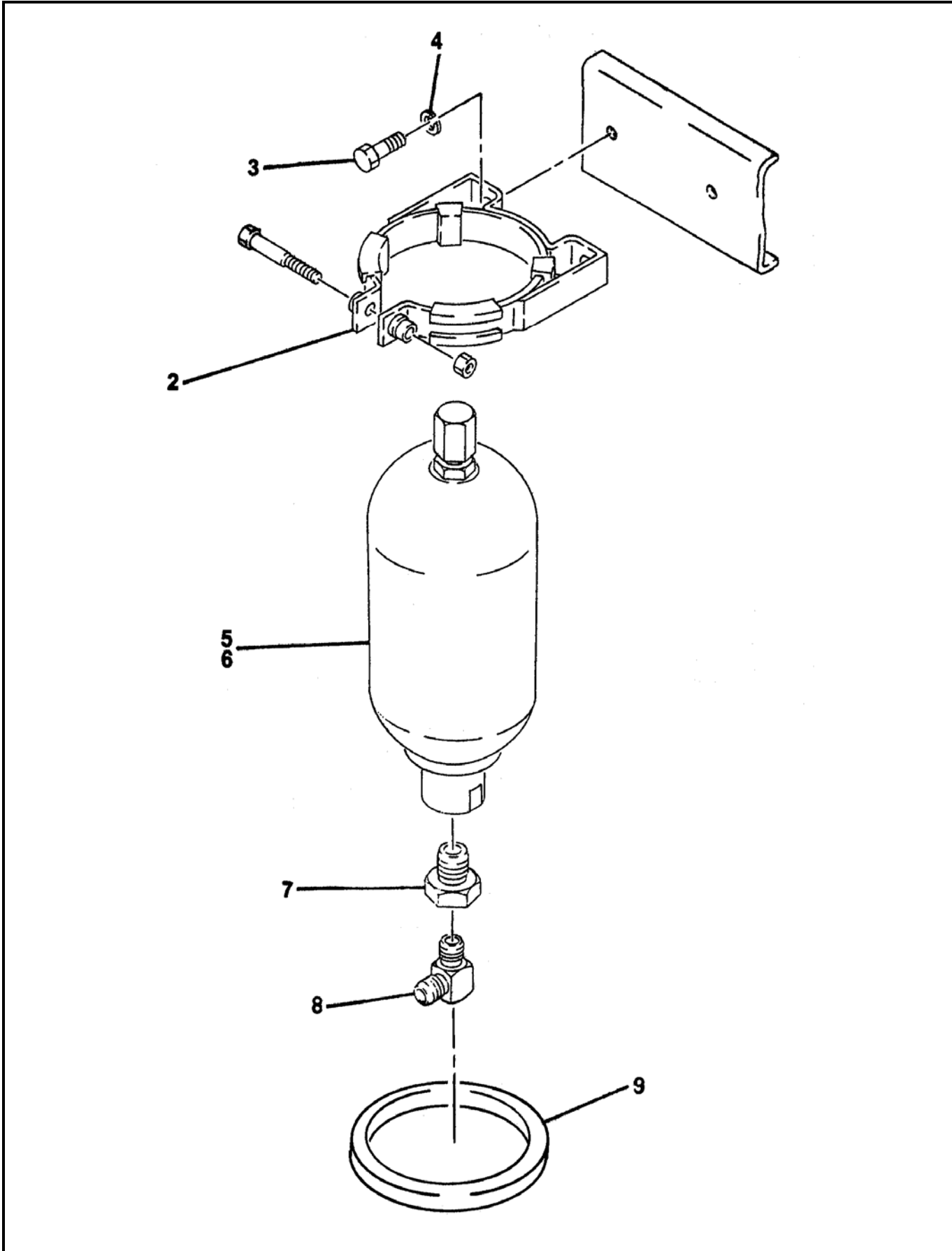



# ACCUMULATOR ASSEMBLY

**B60**  
**PARTS**  
GROUP 30  
FIGURE 10  
PAGE 02

ITEM NO.	REED'S PARTS NO.	DESCRIPTION					QTY
		1	2	3	4	5	
-1	30-10	Assembly, Accumulator (See Group 30, Figure 01 for NHA)					Ref
2	73171	• Bracket, Accumulator					1
3		• Bolt, Hex (attaching parts)					2
4		• Washer, Lock (attaching parts)					2
5	74515	• Accumulator, 1 Gal					1
6	30-11	• Kit, Bladder Repair (See Group 30, Figure 11 for REF)					1
7		• Reducer					1
8		• Elbow, 90					1
9	801028	• Grommet, Accumulator					1
-10	71460	• Kit, Accumulator Charge (See Group 80, Figure 07 for REF)					Ref

DASH (-) ITEM NOT ILLUSTRATED



# ACCUMULATOR BLADDER REPAIR KIT

**B60**  
**PARTS**  
GROUP 30  
FIGURE 11  
PAGE 01

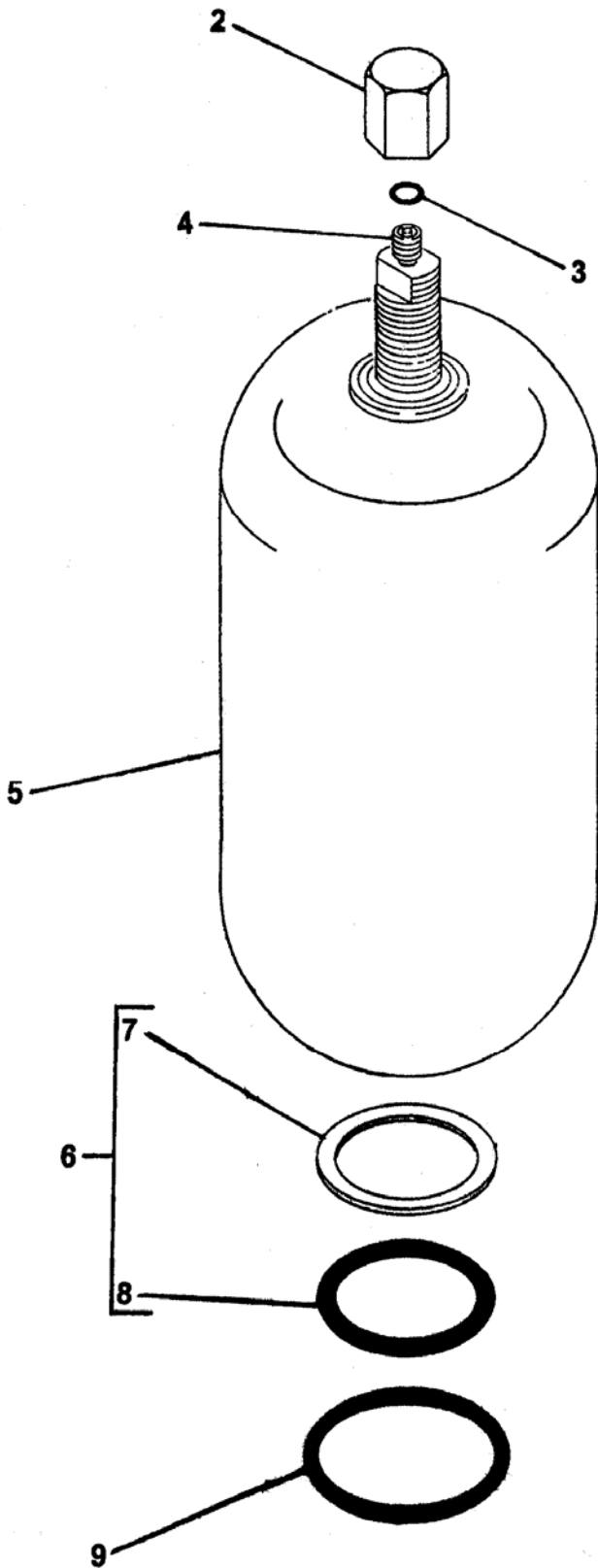





# ACCUMULATOR BLADDER REPAIR KIT

**B60**  
**PARTS**  
GROUP 30  
FIGURE 11  
PAGE 02

ITEM NO.	REED'S PARTS NO.	DESCRIPTION	QTY
		1 2 3 4 5	
-1	30-11	Kit, Bladder Repair (Also See Group 30, Figure 10 for NHA)	Ref
2		• Cap, Valve Seal	1
3		• O-Ring	1
4		• Core, Gas Valve	1
5	74516	• Bladder, 1 Gal	1
6	85812	• Kit, Bladder Seal	1
7		• • Ring, Flat	1
8		• • O-Ring	1
9		• Ring, Back Up	1

DASH (-) ITEM NOT ILLUSTRATED

THIS PAGE INTENTIONALLY LEFT BLANK.

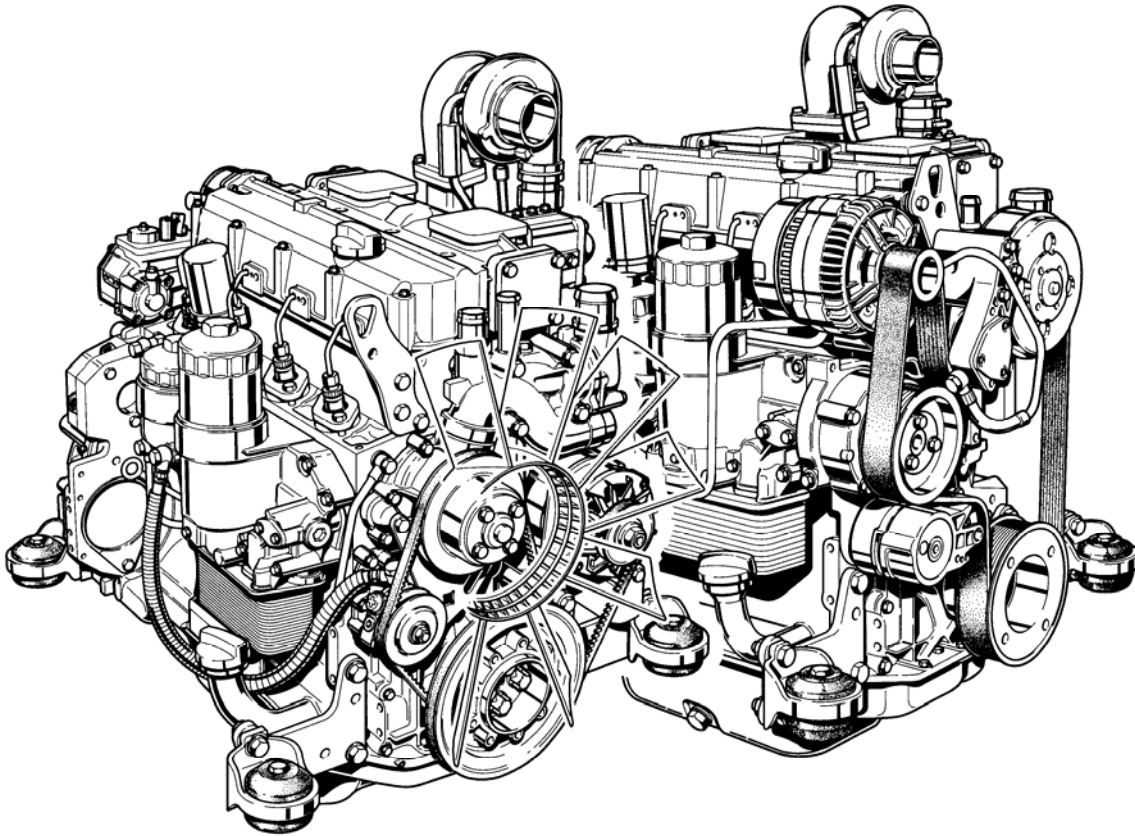

**REED TRAILER MOUNTED CONCRETE PUMP 01 MODEL B60 ILLUSTRATED PARTS MANUAL GROUP 40 POWER TRAIN INSTALLATION CONTAINS THE FOLLOWING FIGURES:**

<b>FIGURE 00</b>	TABLE OF CONTENTS
<b>FIGURE 01</b>	POWER TRAIN INSTALLATION
<b>FIGURE 02</b>	HYDRAULIC PUMPS ASSEMBLY
<b>FIGURE 03</b>	SINGLE AUXILIARY PUMP ASSEMBLY
<b>FIGURE 04</b>	DOUBLE AUXILIARY PUMP ASSEMBLY
<b>FIGURE 05</b>	MAIN PUMP ASSEMBLY
<b>FIGURE 06</b>	BATTERY MOUNTING ASSEMBLY



# POWER TRAIN INSTALLATION

B60  
PARTS  
GROUP 40  
FIGURE 01  
PAGE 01

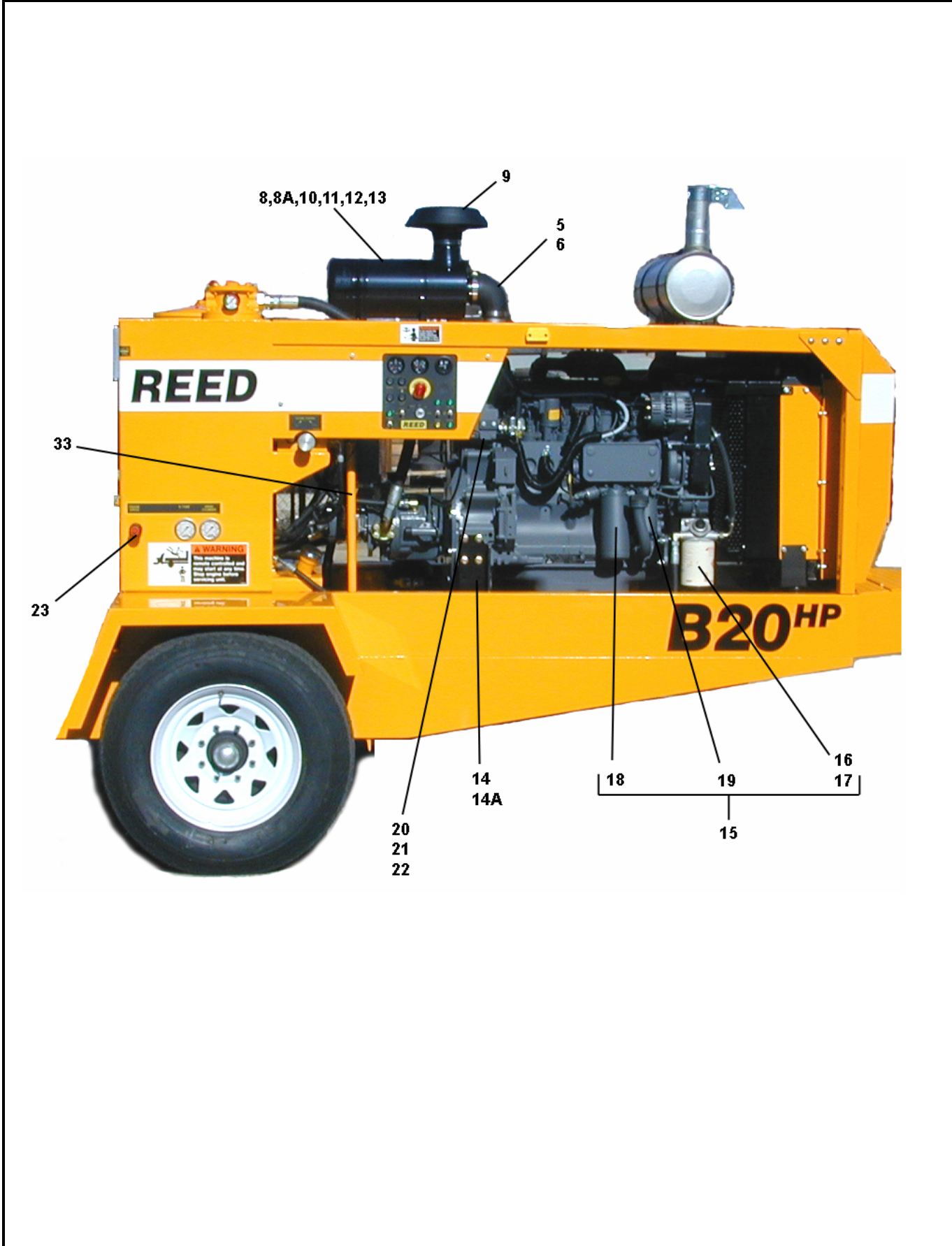

REVISION:



# POWER TRAIN INSTALLATION

B60  
PARTS  
GROUP 40  
FIGURE 01  
PAGE 02

ITEM NO.	REED'S PARTS NO.	DESCRIPTION	QTY
		1 2 3 4 5	
-1	40-01	Installation, Power Train (See Group 10, Figure 01, 02, 03 and 04 for NHA)	Ref
2	40-02	• Assembly, Main and Auxiliary Pumps (See Group 40, Figure 02 for DET)	1
3	87187	• Elbow, 3 Inch Rubber	1
-4	87212	• Bracket, Fuel Filter Mount	1
5	87188	• Elbow, Reducer	1
6	74461	• Clamp	4
7	10577	• Clamp, Hose	2
8	87190	• Cleaner, Air	1
8A	87241	• • Element, Air Cleaner	1
9	87189	• Hood, Inlet	1
10	78193	• Band, Mounting	2
11	87242	• Nut, Wing	1
-11A	85348	• Switch, 12 VDC Solenoid	1
12	87243	• Cap, Dust	1
13	87244	• Valve, Vacuator	1
14	BW10270	• Mount, Engine	4
14A	BW10267	• Washer, Fender 3/4"	4
15	87143	• Assembly, Engine (See Vendor Section, Figure 01 for REF)	1
16	87245	• • Element, Water Separator Filter	1
17	74716	• • Hose, 7 Feet Fuel	1
18	74500	• • Element, Oil Filter	1
19	87239	• • Element, Fuel Filter	1
20	87192	• Bracket, Solenoid Support	1
21	78202	• Coupler, Throttle Cable	1
22	72294	• Bolt, Throttle Control	1
23	78201	• Cable, Throttle Control	1
33	85426	• Tube, Hydraulic Cylinders	2

DASH (-) ITEM NOT ILLUSTRATED

REVISION:



# POWER TRAIN INSTALLATION

B60  
PARTS  
GROUP 40  
FIGURE 01  
PAGE 03

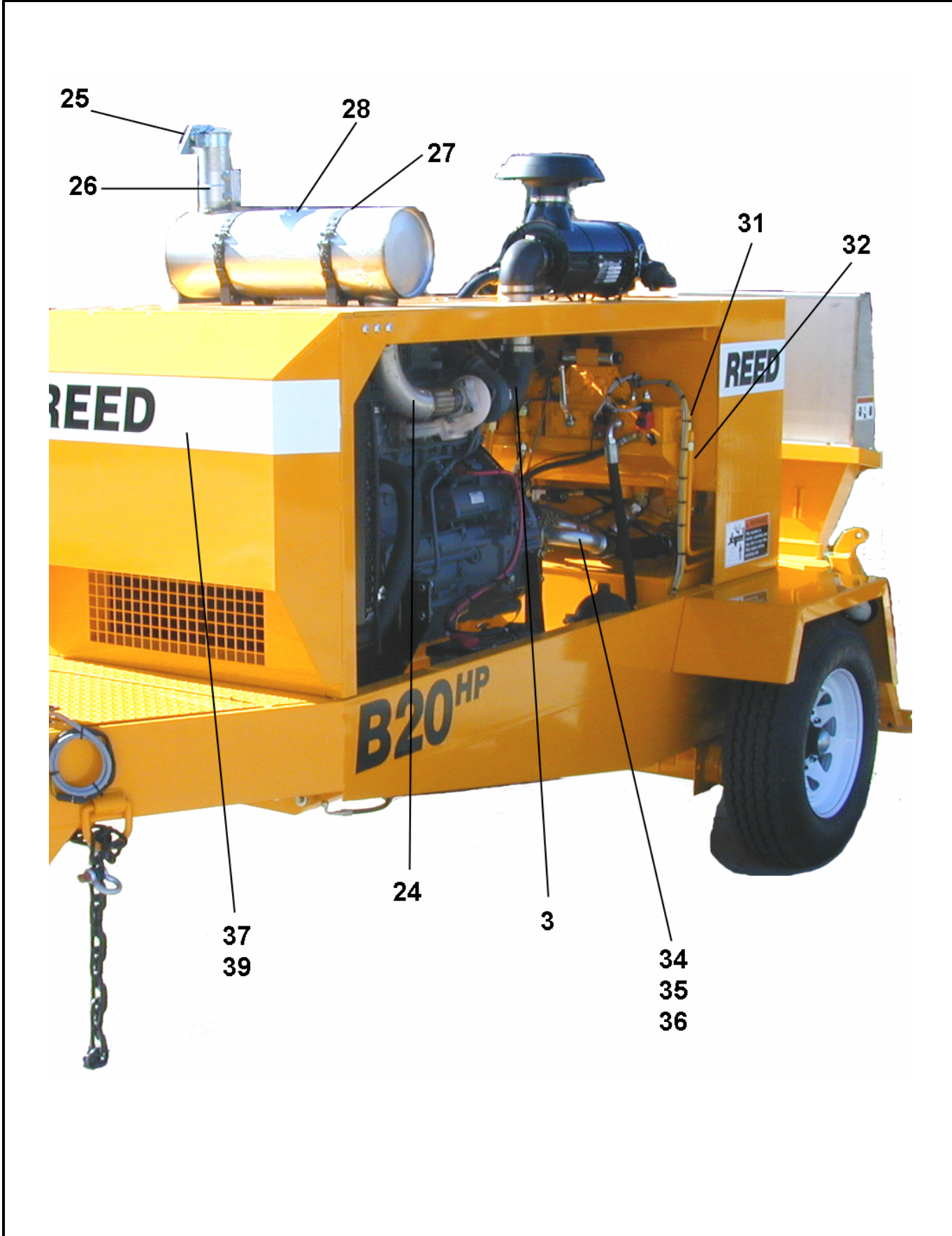

REVISION:



# POWER TRAIN INSTALLATION

B60  
PARTS  
GROUP 40  
FIGURE 01  
PAGE 04

ITEM NO.	REED'S PARTS NO.	DESCRIPTION	QTY
		1 2 3 4 5	
24	87208	• Elbow, Exhaust Weldment	1
25	73475	• Cap, Rain-3"	1
26	87198	• Clamp-3"	1
27	87199	• Band, Air Cleaner Mounting	2
28	87197	• Muffler, Exhaust	1
-29	73269	• Strap, Ground	1
30	77258	• Clamp	1
31	85429	• Tube, Hydraulic Shift Cylinder	1
32	85428	• Tube, Hydraulic Shift Cylinder	1
33	85426	• Tube, Hydraulic Cylinders	2
34	85661-003	• Hose, Main Pump Suction	1
35	74310	• Clamp, Severe Service	4
36	85732	• Adapter, Suction	1
37	BW10277	• Cooler, Oil	1
38	40-06	• Assembly, Battery Mounting (See Group 40, Figure 06 for DET)	1
39	87164	• Ring, Air intake	1
-40	86728-025	• Elbow-MB-MJ90-20-16	2
-41	81002	• Fitting-MB-MJ-8-10	1
-42	86911-008	• Stem 2" 90 32C4-39FL90	2
-43	85264-006	• Split Flange Code 61 32 SAE	2
-44	87162	• Bracket, Cooler Mount-LH	1
-45	87163	• Bracket, Cooler Mount-RH	1
-46	87194	• Assembly, Engine Wiring Harness (See Schematic Section, Page 11 for REF)	1

DASH (-) ITEM NOT ILLUSTRATED

REVISION:



# HYDRAULIC PUMPS ASSEMBLY

B60  
PARTS  
GROUP 40  
FIGURE 02  
PAGE 01

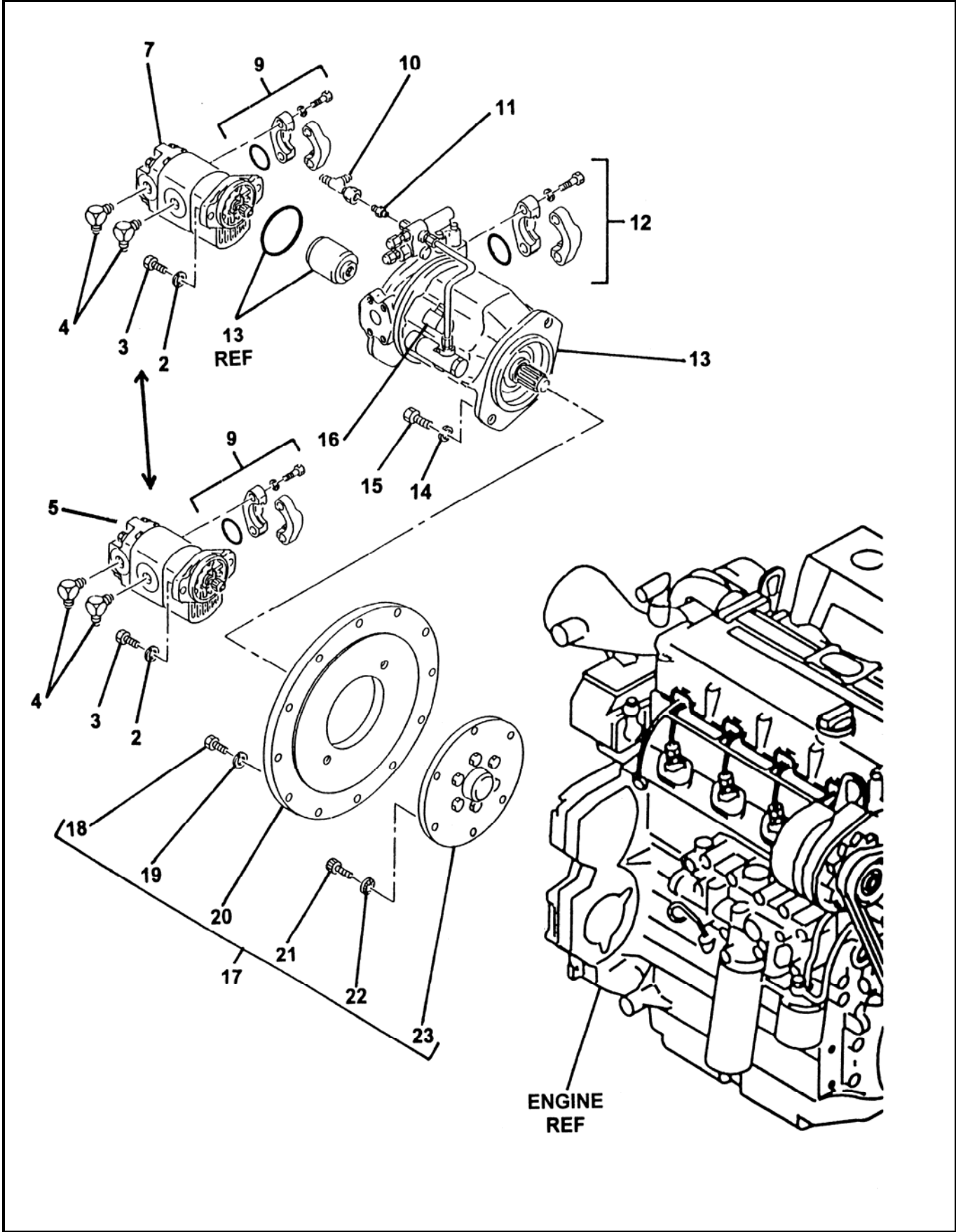

REVISION:





# HYDRAULIC PUMPS ASSEMBLY

B60  
PARTS  
GROUP 40  
FIGURE 02  
PAGE 02

ITEM NO.	REED'S PARTS NO.	DESCRIPTION	QTY
		1 2 3 4 5	
-1	40-02	Assembly, Hydraulic Pump (See Group 40, Figure 01 for NHA)	Ref
2		• Washer, Lock	2
3		• Bolt, Hex	2
4		• Fitting, 90	A/R
5	87153	• Assembly, Double Auxiliary Pump (See Group 40, Figure 04 for DET)	1
-6	85675	• Assembly, Optional Pump	1
7	73156	• • Assembly, Double Auxiliary Pump (See Group 40, Figure 03 for DET)	1
-8	85652	• • Valve, Solenoid	1
9		• Kit, Flange	1
10		• Fitting, Tee	1
11		• Fitting STR	1
12	85264-004	• Kit, Flange	1
13	79560	• Assembly, Main Pump (See Group 40, Figure 05 for DET) (Also See Vendor Section, Figure 02 for REF)	1
14		• Washer, Lock (attaching parts)	2
15		• Bolt, Hex (attaching parts)	2
16		• Fitting, 90	1
17	77876	• Assembly, Flywheel Coupling(Pump Drive)	1
18		• • Bolt, Hex	12
19		• • Washer, SPL	12
20		• • Plate, Flywheel	1
21		• • Screw	6
22		• • Washer	6
23	87144	• • Drive, Flywheel	1

REVISION:



# DOUBLE AUXILIARY PUMP ASSEMBLY

B60  
PARTS  
GROUP 40  
FIGURE 03  
PAGE 01

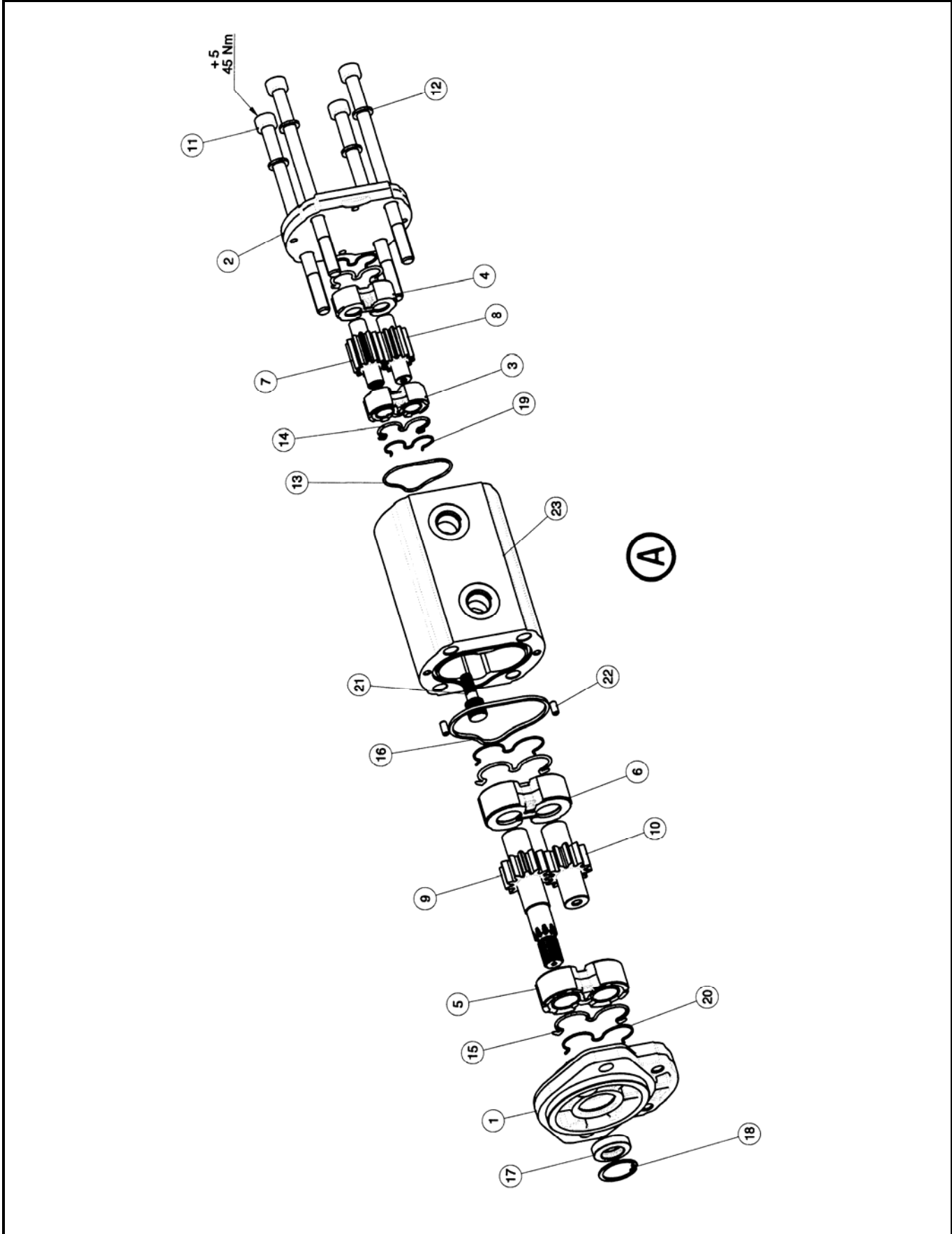

REVISION:



# DOUBLE AUXILIARY PUMP ASSEMBLY

**B60**  
**PARTS**  
GROUP 40  
FIGURE 03  
PAGE 02

ITEM NO.	REED'S PARTS NO.	DESCRIPTION	QTY
		1 2 3 4 5	
A	87153	Assembly, Double Auxiliary Pump (See Group 40, Figure 02 for NHA) (Also See Vendor Section, Figure 02 for REF)	Ref
1		• Cover, Front	1
2		• Cover, Twin Rear	1
3		• Plate, Thrust	1
4		• Plate, Thrust	1
5		• Plate, Thrust	1
6		• Plate, Thrust	1
7		• Gear, Drive	1
8		• Gear, Driven	1
9		• Shaft, Drive	1
10		• Shaft, Driven	1
11		• Screw	4
12		• Washer	4
13		• O-Ring	1
14		• Seal	2
15		• Seal	2
16		• Plate, Seal	1
17		• Seal, Shaft	1
18		• Ring	1
19		• Plate, Anti-Intrusion	2
20		• Ring, Back-Up	2
21		• Hub	1
22		• Pin, Dowel	2
23		• Body	1

REVISION:



# DOUBLE AUXILIARY PUMP ASSEMBLY

B60  
PARTS  
GROUP 40  
FIGURE 04  
PAGE 01

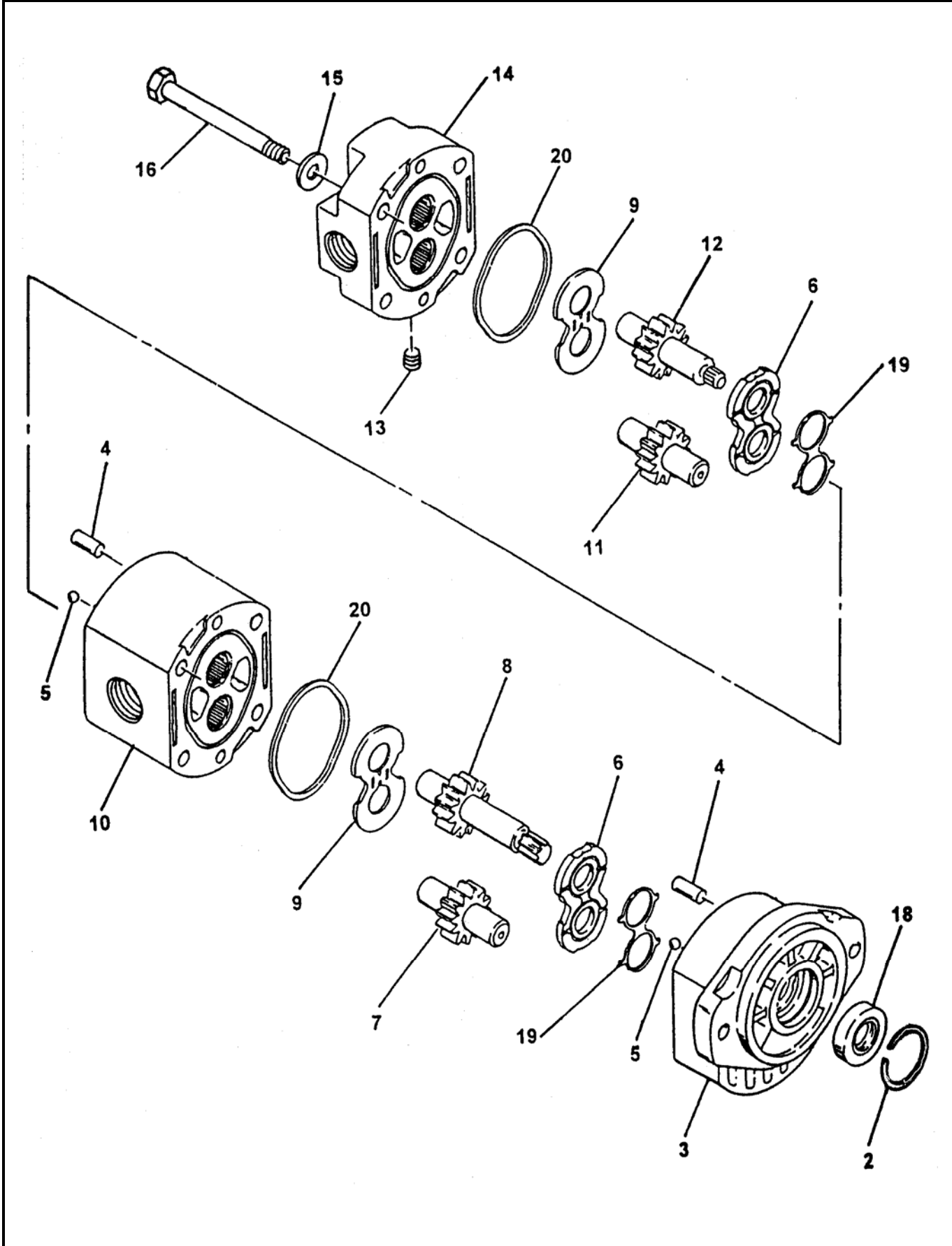

REVISION:



# DOUBLE AUXILIARY PUMP ASSEMBLY

B60  
**PARTS**  
GROUP 40  
FIGURE 04  
PAGE 02

ITEM NO.	REED'S PARTS NO.	DESCRIPTION	QTY
		1 2 3 4 5	
-1	73156	Assembly Double Auxiliary Pump (See Group 40, Figure 02 for NHA)	Ref
2		• Retainer	1
3		• Assembly, Body	1
4		• Pin, Dowel	4
5		• Bearing, Ball	4
6		• Plate, Wear	2
7		• Gear, Driven	1
8		• Gear, Drive	1
9		• Plate, Thrust	2
10		• Assembly, Middle Body	1
11		• Gear, Rear Driven	1
12		• Cover, Rear Drive	1
13		• Plug, Pipe	1
14		• Assembly, Cover	1
15		• Washer, Flat (attaching parts)	4
16		• Screw, Hex (attaching parts)	4
-17	79598	• Kit, Seal	1
18		• • Seal, Shaft	1
19		• • Rubber, Space	2
20		• • Ring, Square Cut	2

DASH (-) ITEM NOT ILLUSTRATED



# MAIN PUMP ASSEMBLY

B60  
PARTS  
GROUP 40  
FIGURE 05  
PAGE 01

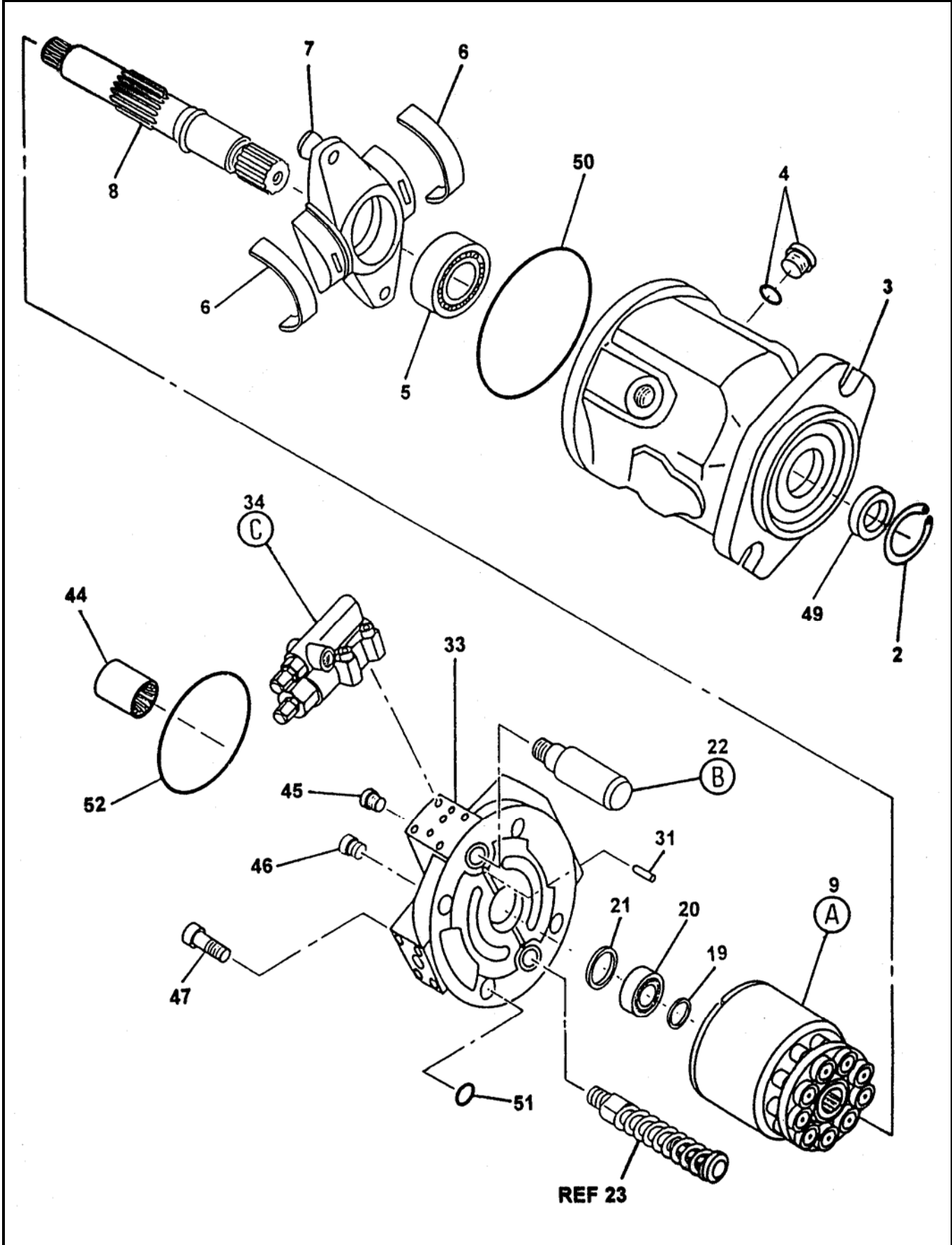

REVISION:



# MAIN PUMP ASSEMBLY

B60  
**PARTS**  
GROUP 40  
FIGURE 05  
PAGE 02

ITEM NO.	REED'S PARTS NO.	DESCRIPTION	QTY
		1 2 3 4 5	
-1	79560	Assembly, Main Pump (See Group 40, Figure 02 for NHA) (Also See Vendor Section, Figure 02 for REF)	Ref
2		• V-Ring, Seeger	1
3		• Housing, Pump	1
4		• Plug, O-Ring	1
5		• Bearing, Tapered Roller	1
6		• Bearing, Cradle	2
7		• Assembly, Cradle	1
8		• Shaft, Drive	1
9		• Assembly, Rotary	1
23		• Assembly, Piston Control	1
33		• Block	1
34		• Assembly, Control Valve	1
44		• Coupling	1
45		• Plug	1
46		• Plug	1
47		• Screw, Cap	2
-48		• Kit, Seal	1
49		•• Seal, Shaft	1
50		•• O-Ring	1
51		•• O-Ring	1
52		•• O-Ring	1

REVISION:



# MAIN PUMP ASSEMBLY

B60  
PARTS  
GROUP 40  
FIGURE 05  
PAGE 03

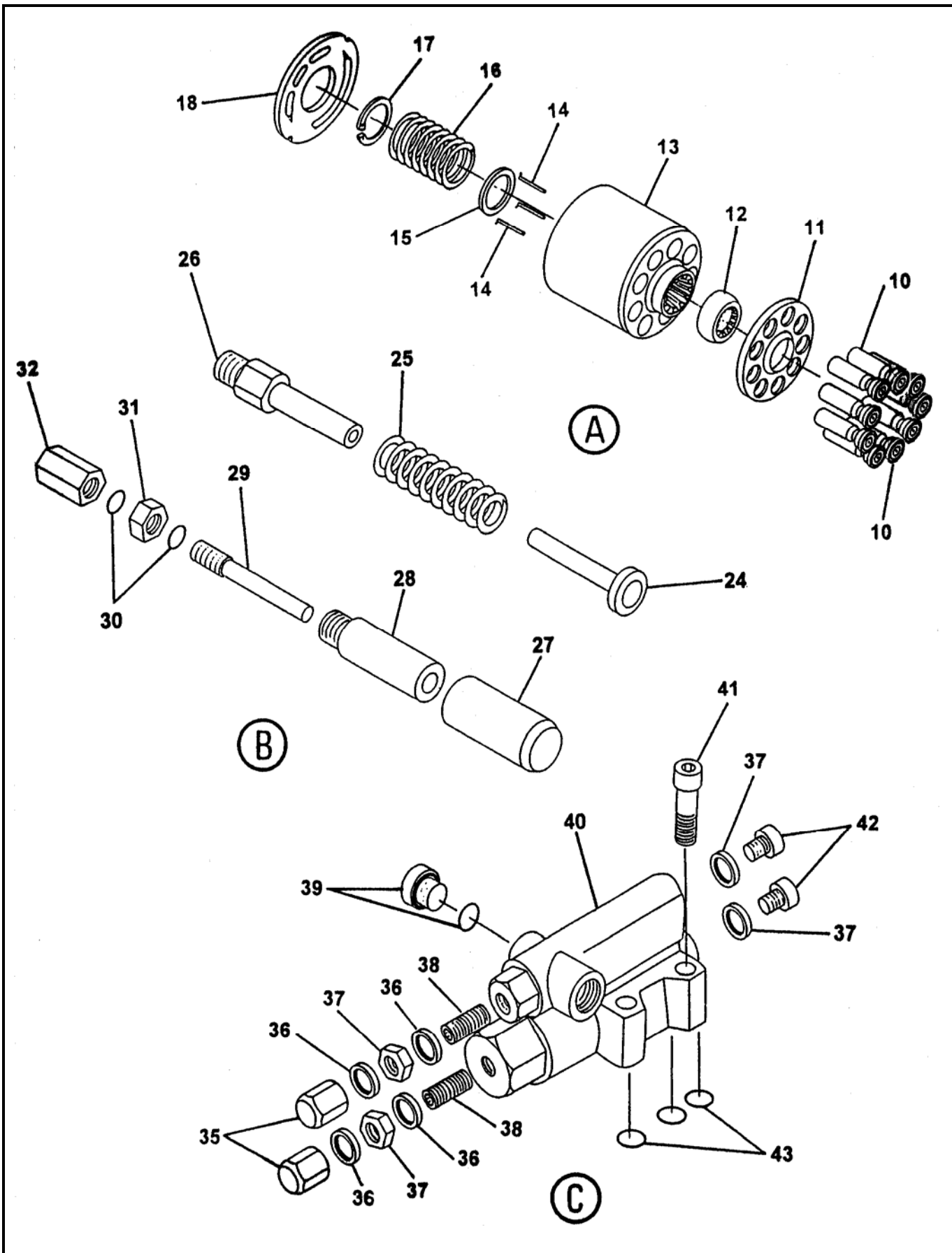

REVISION:





# MAIN PUMP ASSEMBLY

B60  
**PARTS**  
GROUP 40  
FIGURE 05  
PAGE 04

ITEM NO.	REED'S PARTS NO.	DESCRIPTION					QTY
		1	2	3	4	5	
-9		• Assembly, Rotary					1
10		• • Piston					9
11		• • Plate, Retaining					1
12		• • Ball, Retaining					1
13		• • Barrel					1
14		• • Pin, Pressure					3
15		• • Disc, Retaining Clip					1
16		• • Spring					1
17		• • Ring, Retaining					1
18		• • Plate, Lens					1
-23		• Assembly, Piston Control					1
24		• • Piston, Counter					1
25		• • Spring					1
26		• • Guide, Counter Piston					1
27		• • Piston, Counter					1
28		• • Guide, Counter Piston					1
29		• • Screw, Max Volume Adjustment					1
30		• • O-Ring					2
31		• • Nut, Lock					1
32		• • Nut, Acorn					1
-34		• Assembly, Control Valve					1
35		• • Nut, Acorn					2
36		• • O-Ring					3
37		• • Nut, Jam					2
38		• • Screw, Adjusting					2
39		• • Plug, O-Ring					1
40		• • Body, Control Valve					1
41		• • Screw, Cap (attaching parts)					4
42		• • Plug					2
43		• • O-Ring					3

DASH (-) ITEM NOT ILLUSTRATED

REVISION:



# BATTERY MOUNT ASSEMBLY

B60  
PARTS  
GROUP 40  
FIGURE 06  
PAGE 01

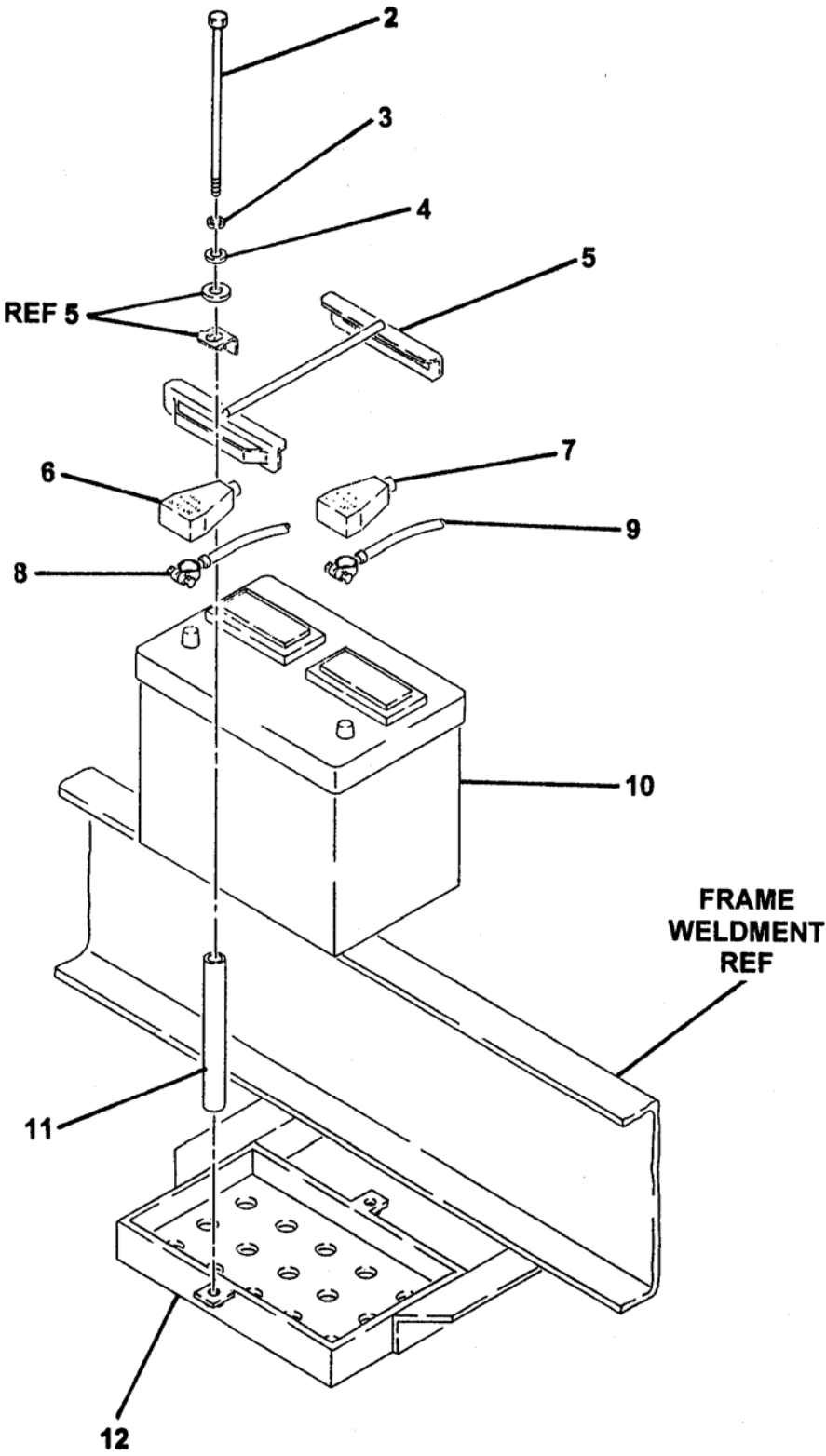

REVISION:



# BATTERY MOUNT ASSEMBLY

B60  
PARTS  
GROUP 40  
FIGURE 06  
PAGE 02

ITEM NO.	REED'S PARTS NO.	DESCRIPTION					QTY
		1	2	3	4	5	
-1	40-06	Assembly, Battery Mounting (See Group 40, Figure 01 for NHA)					Ref
2		• Bolt, Hex					2
3		• Washer, Lock					2
4		• Washer Flat					2
5	72945	• Holder, Battery Down					1
6	77720	• Insulator, Negative Battery (Black)					1
7	77719	• Insulator, Positive Battery (Red)					1
8	75116	• Cable, Negative Battery (Black)					1
9	72016	• Cable, 24 Inch Long Positive Battery (Red)					1
10	77075	• Battery, 12 VDC					1
11	73753	• Spacer, Battery Mounting					2
12	72954	• Weldment, Battery Box					1
-13	72014	• Cable, 36 Inch Long Battery Top					1
-14	85348	• Connector, SPNO 12 VDC					1

DASH (-) ITEM NOT ILLUSTRATED

THIS PAGE INTENTIONALLY LEFT BLANK.

**REED TRAILER MOUNTED CONCRETE PUMP 01 MODEL B60 ILLUSTRATED PARTS MANUAL GROUP 50 CONTROLS INSTALLATION CONTAINS THE FOLLOWING FIGURES:**

- FIGURE 00** TABLE OF CONTENTS
- FIGURE 01** CONTROLS INSTALLATION
- FIGURE 02** CONTROL BOX ASSEMBLY
- FIGURE 03** 50 FEET CABLE REMOTE CONTROL ASSEMBLY
- FIGURE 04** 100 FEET CABLE REMOTE CONTROL ASSEMBLY
- FIGURE 05** RADIO REMOTE CONTROL ASSEMBLY

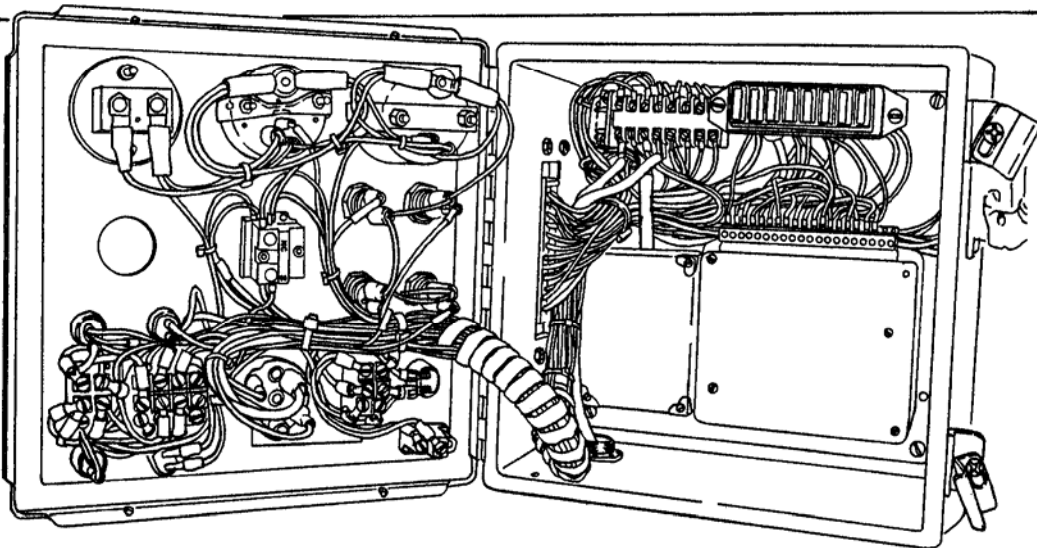
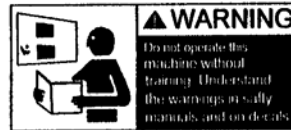



# CONTROL INSTALLATION

**B60**  
**PARTS**  
GROUP 50  
FIGURE 01  
PAGE 01

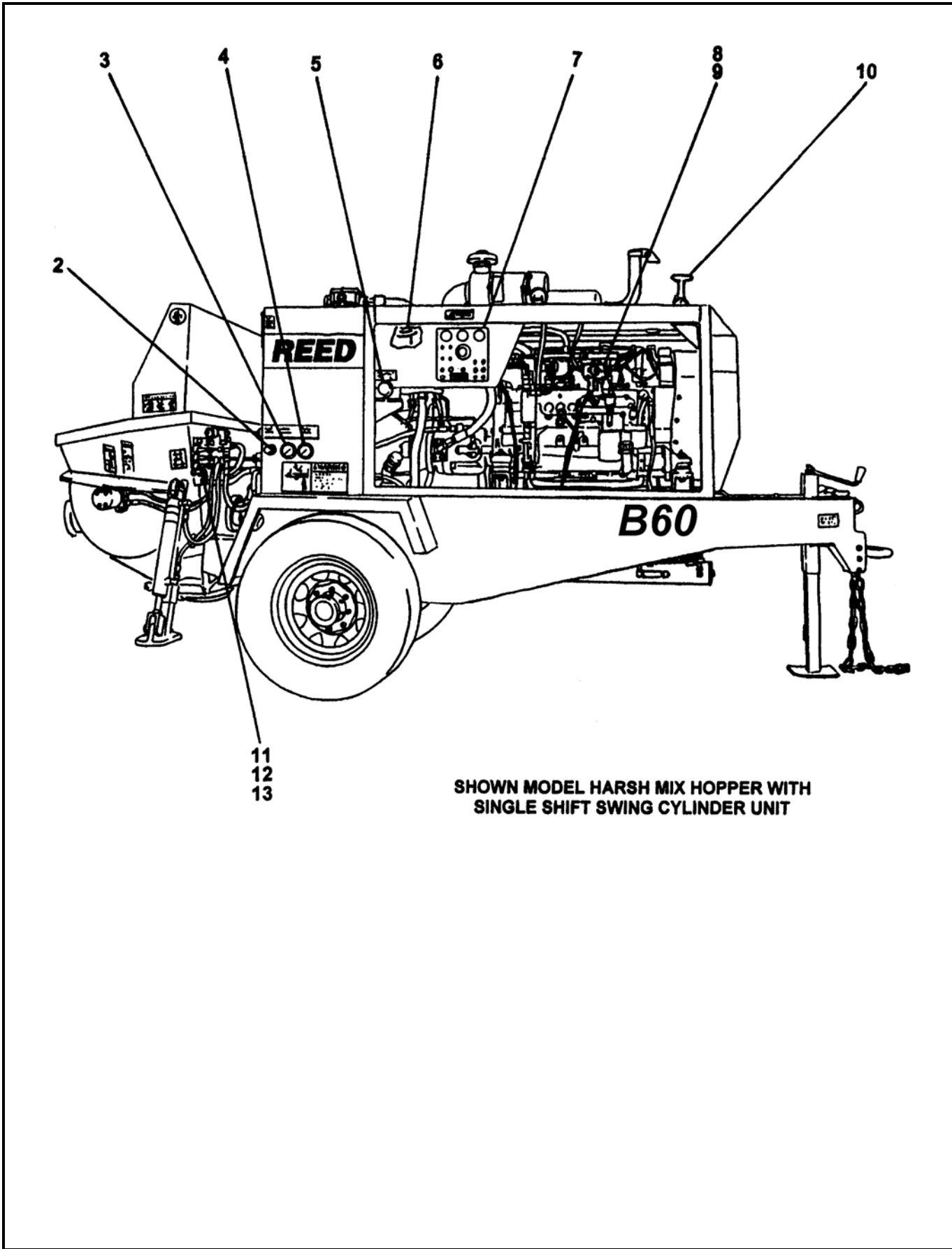

SHOWN MODEL HARSH MIX HOPPER WITH  
SINGLE SHIFT SWING CYLINDER UNIT

REVISION:



# CONTROL INSTALLATION

**B60**  
**PARTS**  
GROUP 50  
FIGURE 01  
PAGE 02

ITEM NO.	REED'S PARTS NO.	DESCRIPTION	QTY
		1 2 3 4 5	
-1	50-01	Installation, Control (See Group 10, Figure 01, 02, 03 and 04 for NHA)	Ref
2	78201	• Cable, Throttle Control (See Group 40, Figure 01 for REF)	1
3	70366	• Gauge, 3,000 PSI Hydraulic (See Group 30, Figure 02 for REF)	1
4	74562	• Gauge, 6,000 PSI Hydraulic (See Group 30, Figure 02 for REF)	1
5	85697	• Cartridge, Flow Control Valve (See Group 30, Figure 07 for REF)	1
6	800347	• Horn, 12 V	1
7	85358	• Assembly, Control Box (See Group 50, Figure 02 for DET)	1
8	85359	• Assembly, 50 Feet Cable Remote Control (See Group 50, Figure 03 for DET)	1
9	85359A	• Assembly, 100 Feet Cable Remote Control (See Group 50, Figure 04 for DET)	1
10	85818	• Assembly, Radio Remote Control (Optional Item) (See Group 50, Figure 05 for DET)	1
11	20-09	• Assembly, 3 Spool Control Valve (Optional Item) (See Group 20, Figure 08 for REF)	1
12	80-16	• Assembly, 1 Spool Control Valve (Optional Item) (See Group 80, Figure 16 for REF)	1
13	80-18	• Assembly, 2 Spool Control Valve (Optional Item) (See Group 80, Figure 18 for REF)	1

DASH (-) ITEM NOT ILLUSTRATED



# CONTROL BOX ASSEMBLY

B60  
PARTS  
GROUP 50  
FIGURE 02  
PAGE 01

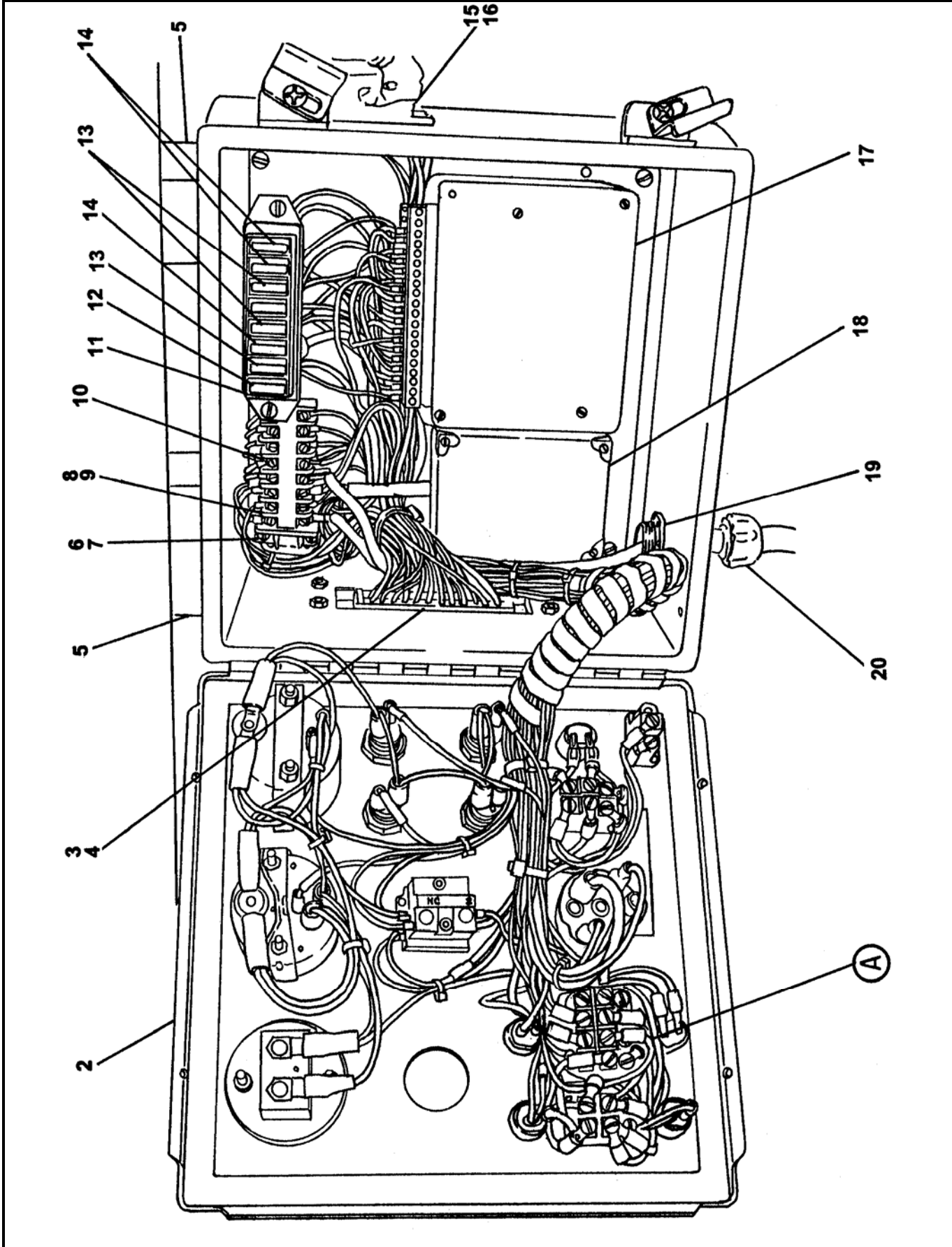

REVISION:





# CONTROL BOX ASSEMBLY

**B60**  
**PARTS**  
GROUP 50  
FIGURE 02  
PAGE 02

ITEM NO.	REED'S PARTS NO.	DESCRIPTION					QTY
		1	2	3	4	5	
-1	85358	Assembly, Control Box (See Group 50, Figure 01 for NHA)					Ref
2	85400	• Box, Control					1
3	78696	• Insert, Connector					1
4	78697	• Base, Connector					1
5	73748	• Bumper					4
6	75654	• End, Barrier					1
7	72821	• Rail, 0.333 Feet Barrier					1
8	72820	• Terminal					8
9	72824	• Jumper					2
10	85354	• Block, Fuse					1
11	85419	• Stand Off					1
12	800447	• Fuse, 25					1
13	800449	• Fuse, 10					4
14	90392	• Fuse, 5					3
15	79963	• Insert, Connector					1
16	79965	• Base, Connector					1
17	85596	• Box, Black					1
18	85334	• Box, Pump Black					1
19	10528	• Nut					1
20	10523	• Relief, Strain					1

DASH (-) ITEM NOT ILLUSTRATED



# CONTROL BOX ASSEMBLY

**B60**  
**PARTS**  
GROUP 50  
FIGURE 02  
PAGE 03

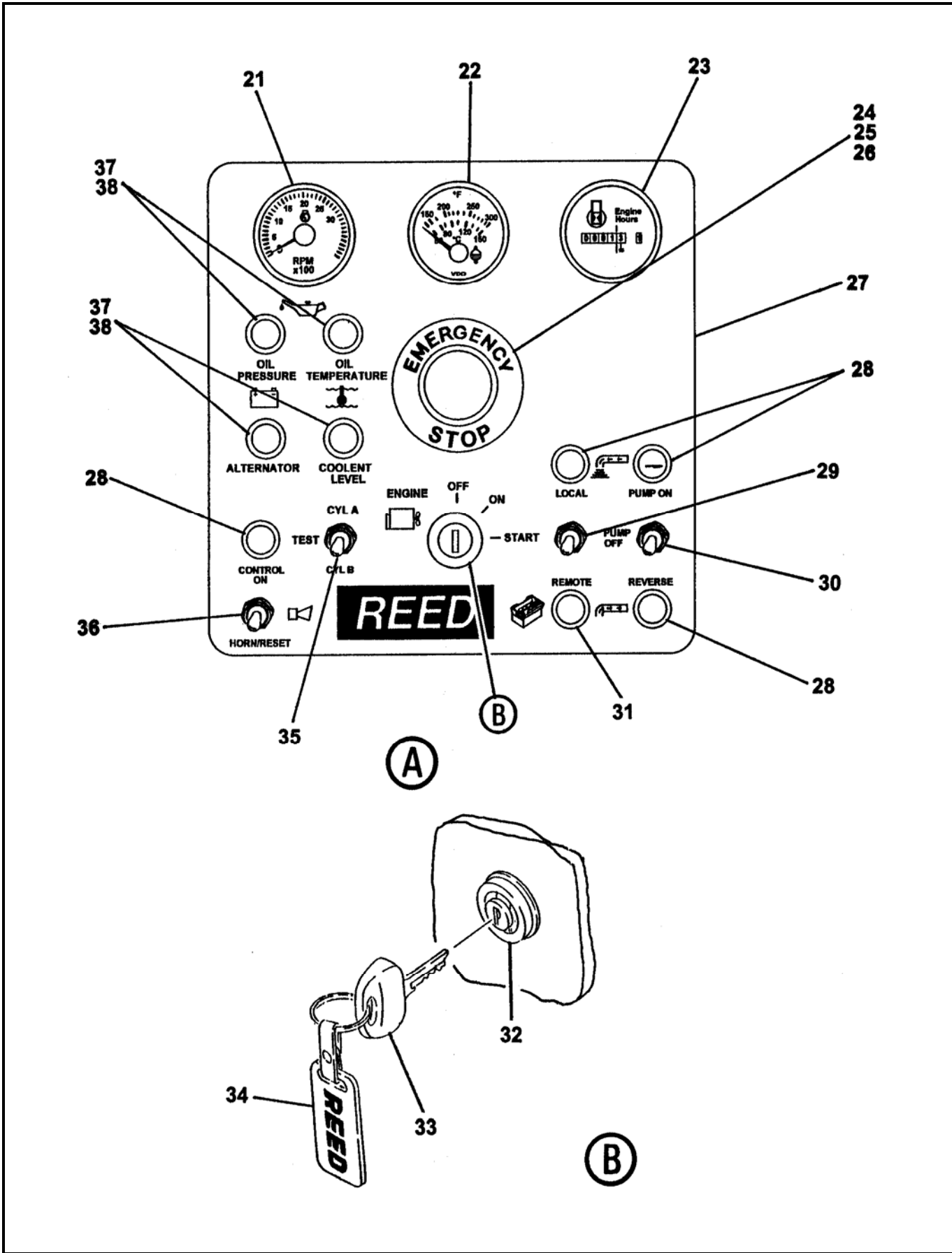

REVISION:



# CONTROL BOX ASSEMBLY

**B60**  
**PARTS**  
GROUP 50  
FIGURE 02  
PAGE 04

ITEM NO.	REED'S PARTS NO.	DESCRIPTION					QTY
		1	2	3	4	5	
21	78687	• Tachometer					1
22	78203	• Gauge, Water Temperature					1
23	74240	• Meter, Engine Hour					1
24	85342	• Operator, Emergency Stop					1
25	85343	• Block, Contact					1
26	85344	• Bulb, Emergency Stop					1
27	85332	• Decal, Control Box					1
28	85355	• Pilot, Light					4
29	78563	• Switch, Local / Remote					1
30	72003	• Switch, Pump On / Reverse					1
31	85356	• Pilot, Light					1
32	71154	• Switch, Ignition					1
33	71155	• • Key (Pair)					1
34	72862	• Gauge, Proximity Switch					1
35	85346	• Switch, CYL A / CYL B					1
36	85347	• Switch, Horn / Reset					1
37	73775	• Indicator, Red Light 14 VDC					4
38	72022	• Bulb, Indicator					4
-39	85396	• Assembly, Engine Wiring Harness (See Schematic Section, Page 11 for REF)					1
-40	86533	• Assembly, Trailer Wiring Harness (See Schematic Section, Page 12 for REF)					1

DASH (-) ITEM NOT ILLUSTRATED



50 FEET CABLE  
REMOTE CONTROL ASSEMBLY

B60  
PARTS  
GROUP 50  
FIGURE 03  
PAGE 01

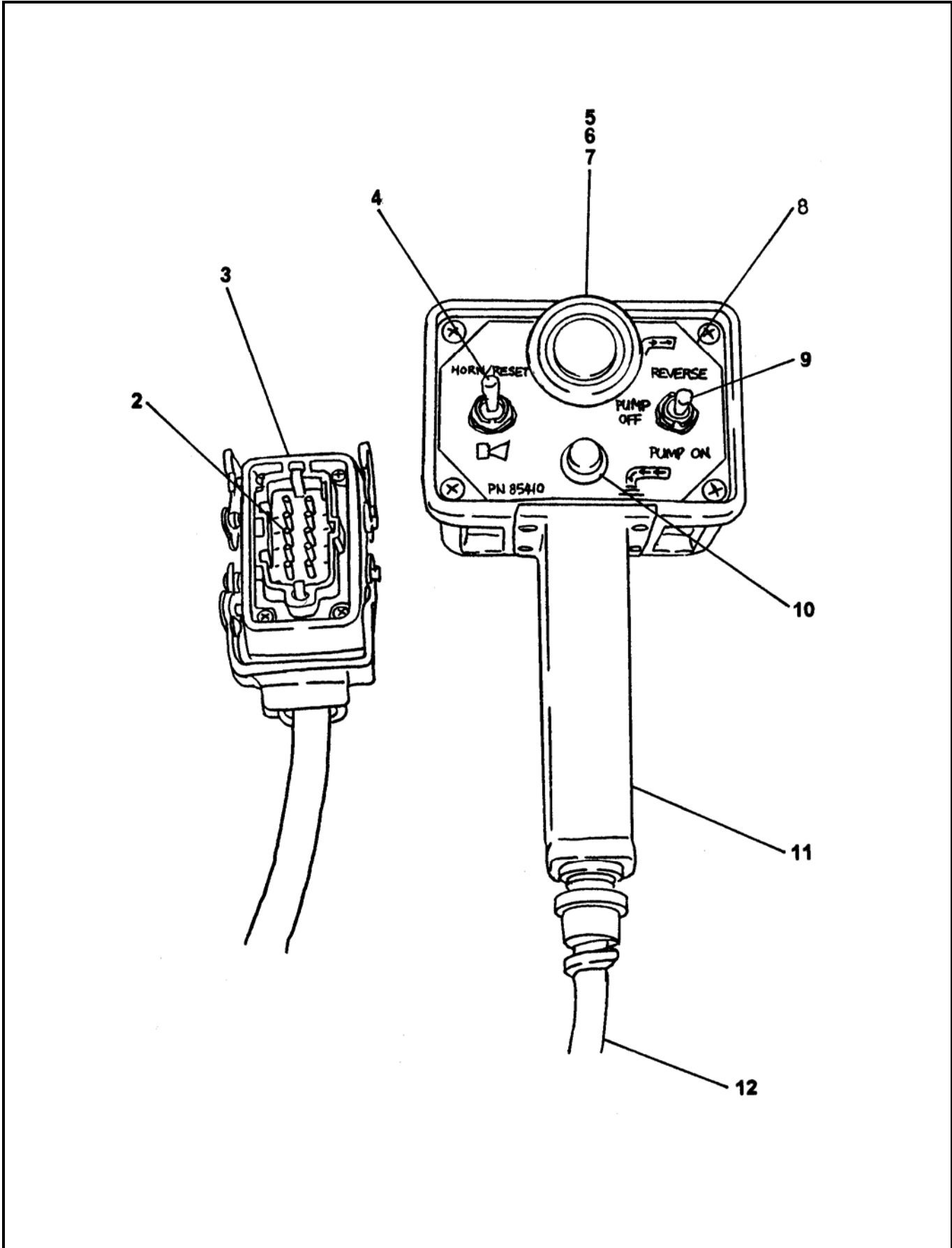

REVISION:



**50 FEET CABLE  
REMOTE CONTROL ASSEMBLY**

**B60**  
**PARTS**  
GROUP 50  
FIGURE 03  
PAGE 02

ITEM NO.	REED'S PARTS NO.	DESCRIPTION	QTY
		1 2 3 4 5	
-1	85359	Assembly, 50 Feet Cable Remote Control (See Group 50, Figure 01 for NHA)	Ref
2	79964	• Connector, Insert	1
3	79966	• Connector, Hood	1
4	85347	• Switch, Horn / Reset	1
5	85342	• Operator, Emergency Stop	1
6	85343	• Block, Contact	1
7	85344	• Bulb, Emergency Stop	1
8	85410	• Decal, Remote Control Box	1
9	72003	• Switch, Pump On / Reverse	1
10	85355	• Pilot, Light	1
11	71999	• Pistol, Grip	1
12	85620	• Cable, 50 Feet Remote Control	1

DASH (-) ITEM NOT ILLUSTRATED

REVISION:



100 FEET CABLE  
REMOTE CONTROL ASSEMBLY

B60  
PARTS  
GROUP 50  
FIGURE 04  
PAGE 01

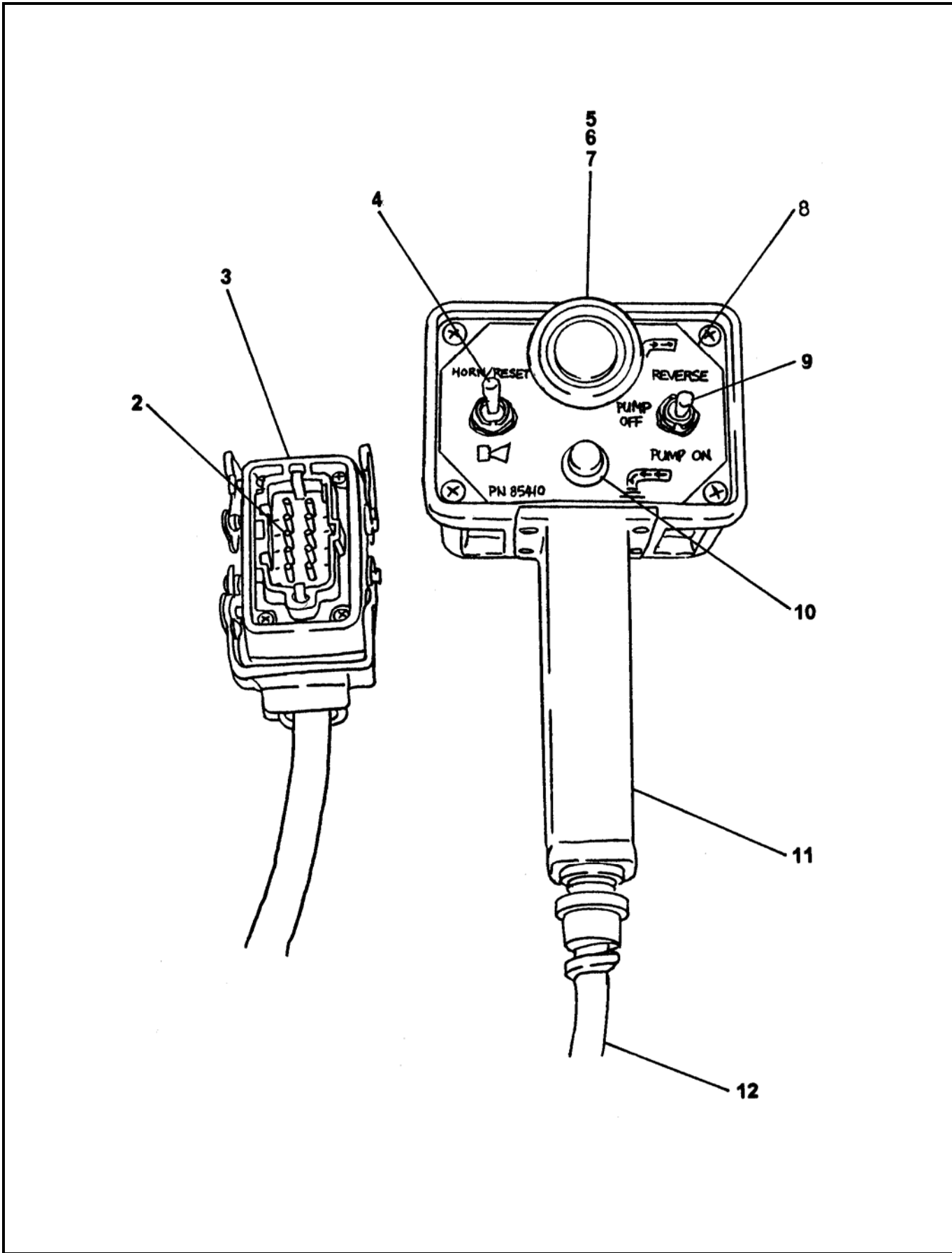

REVISION:



**100 FEET CABLE  
REMOTE CONTROL ASSEMBLY**

**B60**  
**PARTS**  
GROUP 50  
FIGURE 04  
PAGE 02

ITEM NO.	REED'S PARTS NO.	DESCRIPTION	QTY
		1 2 3 4 5	
-1	85359A	Assembly, 100 Feet Cable Remote Control (See Group 50, Figure 01 for NHA)	Ref
2	79964	• Connector, Insert	1
3	79966	• Connector, Hood	1
4	85347	• Switch, Horn / Reset	1
5	85342	• Operator, Emergency Stop	1
6	85343	• Block, Contact	1
7	85344	• Bulb, Emergency Stop	1
8	85410	• Decal, Remote Control Box	1
9	72003	• Switch, Pump On / Reverse	1
10	85355	• Pilot, Light	1
11	71999	• Pistol, Grip	1
12	85816	• Cable, 100 Feet Remote Control	1

DASH (-) ITEM NOT ILLUSTRATED



OPTIONAL RADIO  
REMOTE CONTROL ASSEMBLY

B60  
PARTS  
GROUP 50  
FIGURE 05  
PAGE 01



REVISION:





**OPTIONAL RADIO  
REMOTE CONTROL ASSEMBLY**

**B60**  
**PARTS**  
GROUP 50  
FIGURE 05  
PAGE 02

THIS GROUP 50, FIGURE 05, PARTS NUMBER 85818,  
**OPTIONAL RADIO REMOTE CONTROL ASSEMBLY,**  
DETAIL PARTS LIST IS NOT AVAILABLE THIS REVISION.

REVISION:



**TRAILER MOUNTED PUMP MODEL *B60*  
ILLUSTRATED PARTS MANUAL**

***B60***  
**PARTS**  
GROUP 50  
FIGURE 06  
PAGE 01

THIS PAGE INTENTIONALLY LEFT BLANK.

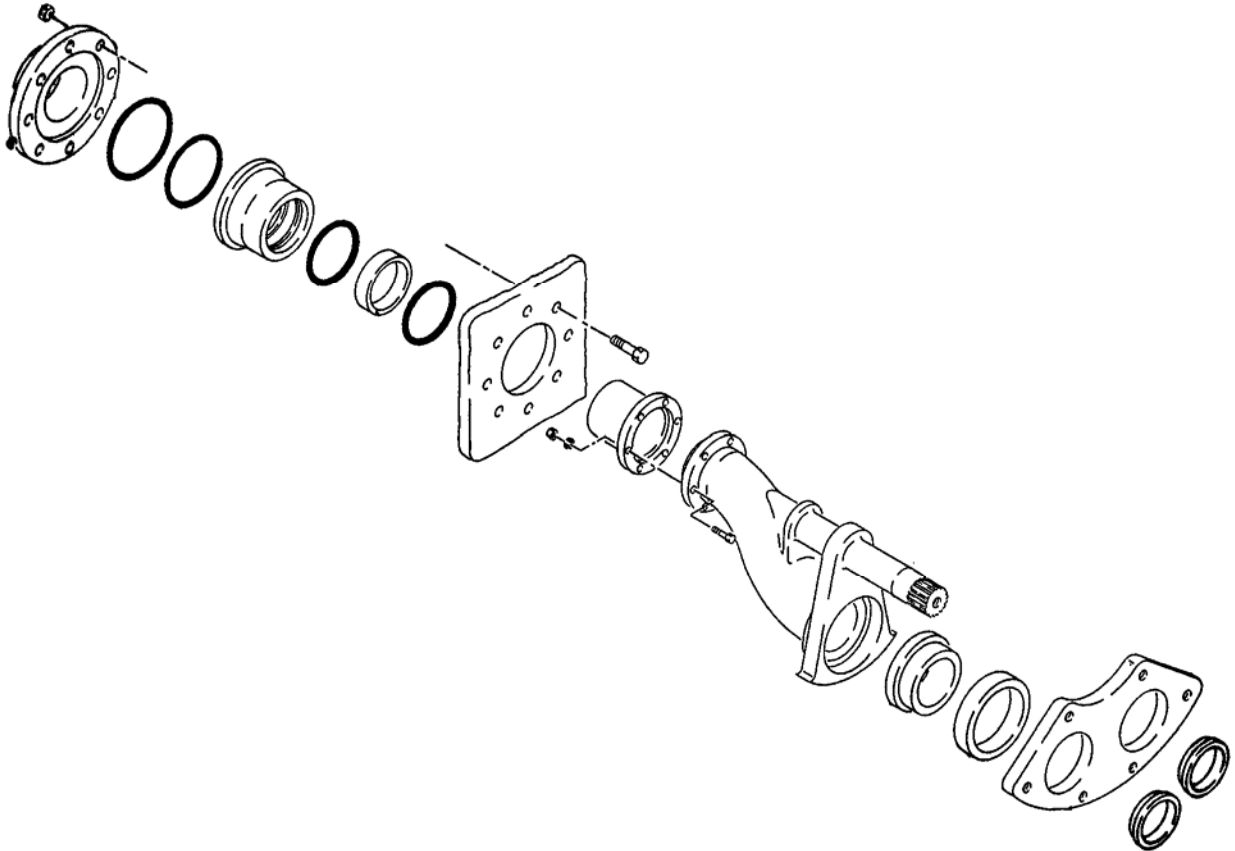

**REED TRAILER MOUNTED CONCRETE PUMP 01 MODEL B60 ILLUSTRATED PARTS MANUAL GROUP 60 PUMPING TRAIN INSTALLATION CONTAINS THE FOLLOWING FIGURES:**

- |                  |                                              |
|------------------|----------------------------------------------|
| <b>FIGURE 00</b> | TABLE OF CONTENTS                            |
| <b>FIGURE 01</b> | SINGLE SHIFT PUMPING TRAIN INSTALLATION      |
| <b>FIGURE 02</b> | DUAL SHIFT PUMPING TRAIN INSTALLATION        |
| <b>FIGURE 03</b> | SINGLE SHIFT SWING VALVE ASSEMBLY            |
| <b>FIGURE 04</b> | DUAL SHIFT SWING VALVE ASSEMBLY              |
| <b>FIGURE 05</b> | SINGLE SHIFT SWING RAM CYLINDER SUB-ASSEMBLY |
| <b>FIGURE 06</b> | DUAL SHIFT SWING RAM CYLINDER SUB-ASSEMBLY   |
| <b>FIGURE 07</b> | MATERIAL CYLINDER ASSEMBLY                   |
| <b>FIGURE 08</b> | FLUSHBOX ASSEMBLY                            |
| <b>FIGURE 09</b> | HYDRAULIC DRIVE CYLINDER ASSEMBLY            |
| <b>FIGURE 10</b> | HYDRAULIC DRIVE CYLINDER SUB-ASSEMBLY        |



# SINGLE SHIFT PUMPING TRAIN INSTALLATION

**B60**  
**PARTS**  
GROUP 60  
FIGURE 01  
PAGE 01

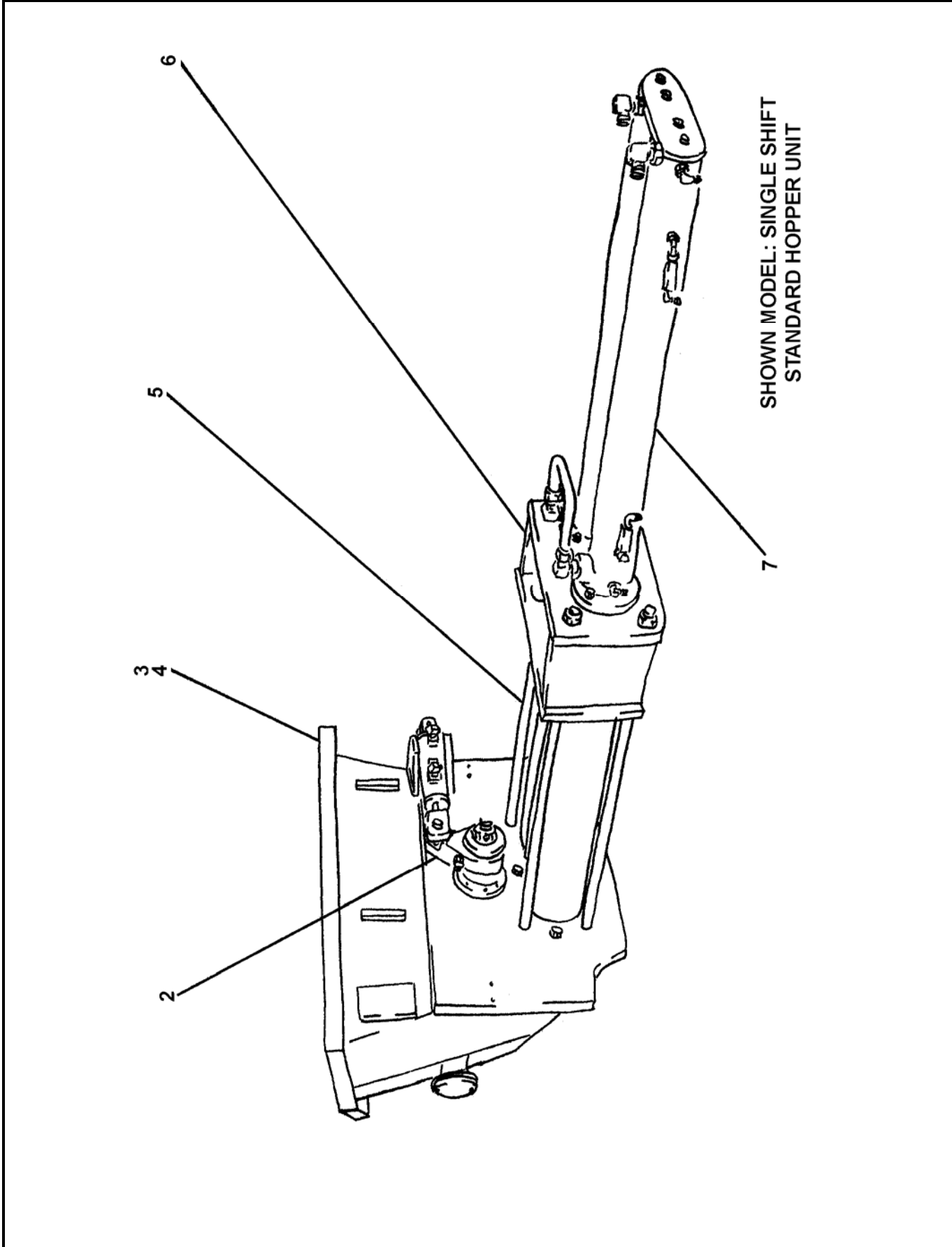

REVISION:



**SINGLE SHIFT  
PUMPING TRAIN INSTALLATION**

**B60**  
**PARTS**  
GROUP 60  
FIGURE 01  
PAGE 02

ITEM NO.	REED'S PARTS NO.	DESCRIPTION	QTY
		1 2 3 4 5	
-1	60-01	Installation, Single Shift Pumping Train (See Group 10, Figure 01 and Figure 03 for NHA)	Ref
2	60-03	• Assembly, Single Shift Swing Valve (See Group 60, Figure 03 for DET)	1
3	20-01	• Installation, Standard Hopper (See Group 20, Figure 01 for REF)	Ref
4	20-02	• Installation, Harsh Mix Hopper (See Group 20, Figure 02 for REF)	Ref
5	86309	• Assembly, Material Cylinder (See Group 60, Figure 07 for DET)	1
6	60-08	• Assembly, Flushbox (See Group 60, Figure 08 for DET)	1
7	86304	• Assembly, Hydraulic Drive Cylinder (See Group 60, Figure 09 for DET)	1

DASH (-) ITEM NOT ILLUSTRATED



# DUAL SHIFT PUMPING TRAIN INSTALLATION

**B60**  
**PARTS**  
GROUP 60  
FIGURE 02  
PAGE 01

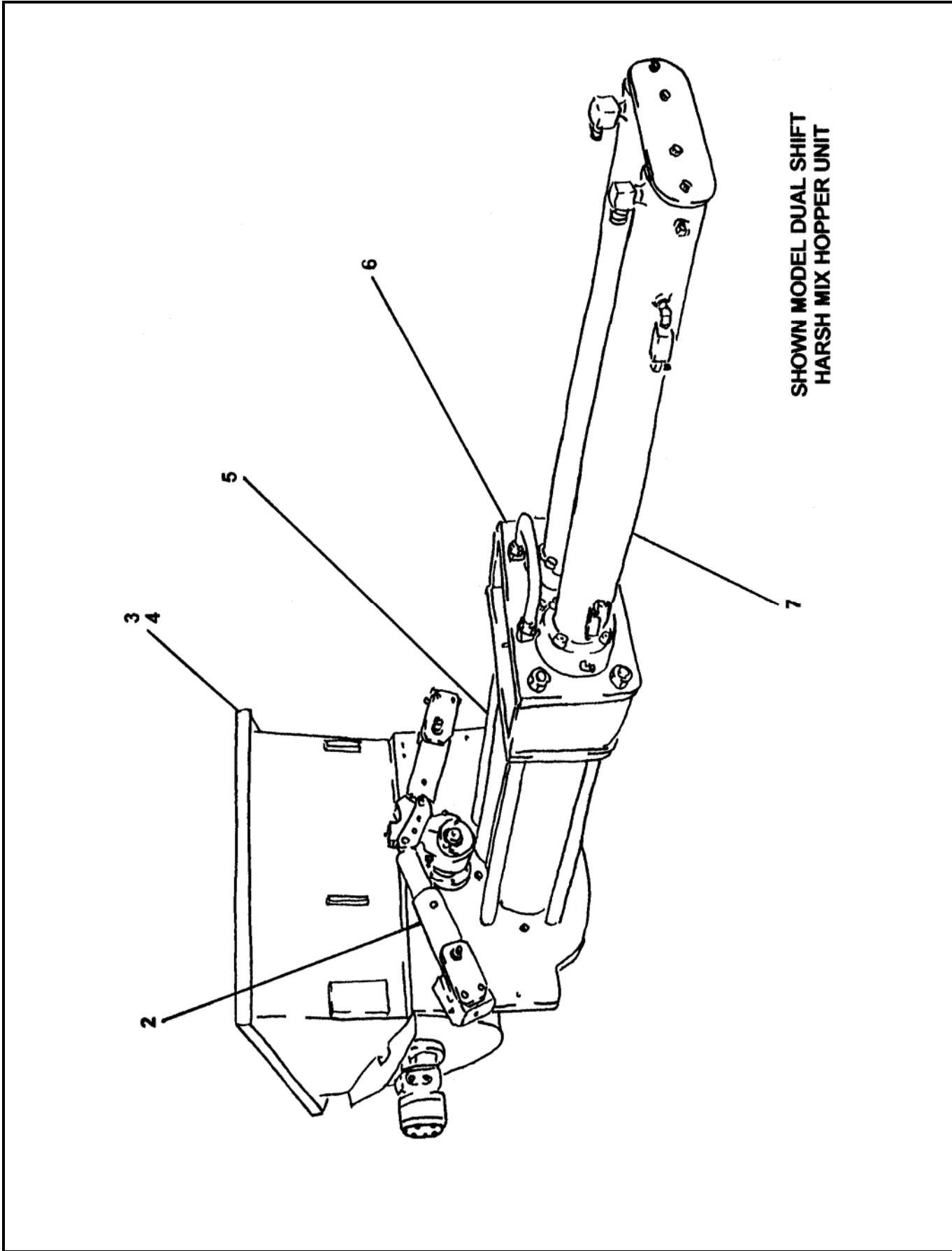

SHOWN MODEL DUAL SHIFT  
HARSH MIX HOPPER UNIT

REVISION:



# DUAL SHIFT PUMPING TRAIN INSTALLATION

**B60**  
**PARTS**  
GROUP 60  
FIGURE 02  
PAGE 02

ITEM NO.	REED'S PARTS NO.	DESCRIPTION	QTY
		1 2 3 4 5	
-1	60-02	Installation, Dual Shift Pumping Train (See Group 10, Figure 02 and Figure 04 for NHA)	Ref
2	60-04	• Assembly, Dual Shift Swing Valve (See Group 60, Figure 04 for DET)	1
3	20-01	• Installation, Standard Hopper (See Group 20, Figure 01 for REF)	Ref
4	20-02	• Installation, Harsh Mix Hopper (See Group 20, Figure 02 for REF)	Ref
5	86309	• Assembly, Concrete Cylinder (See Group 60, Figure 07 for DET)	1
6	86307	• Assembly, Flushbox (See Group 60, Figure 08 for DET)	1
7	86303	• Assembly, Hydraulic Drive Cylinder (See Group 60, Figure 09 for DET)	1

DASH (-) ITEM NOT ILLUSTRATED

REVISION:



# SINGLE SHIFT SWING VALVE ASSEMBLY

**B60**  
**PARTS**  
GROUP 60  
FIGURE 03  
PAGE 01

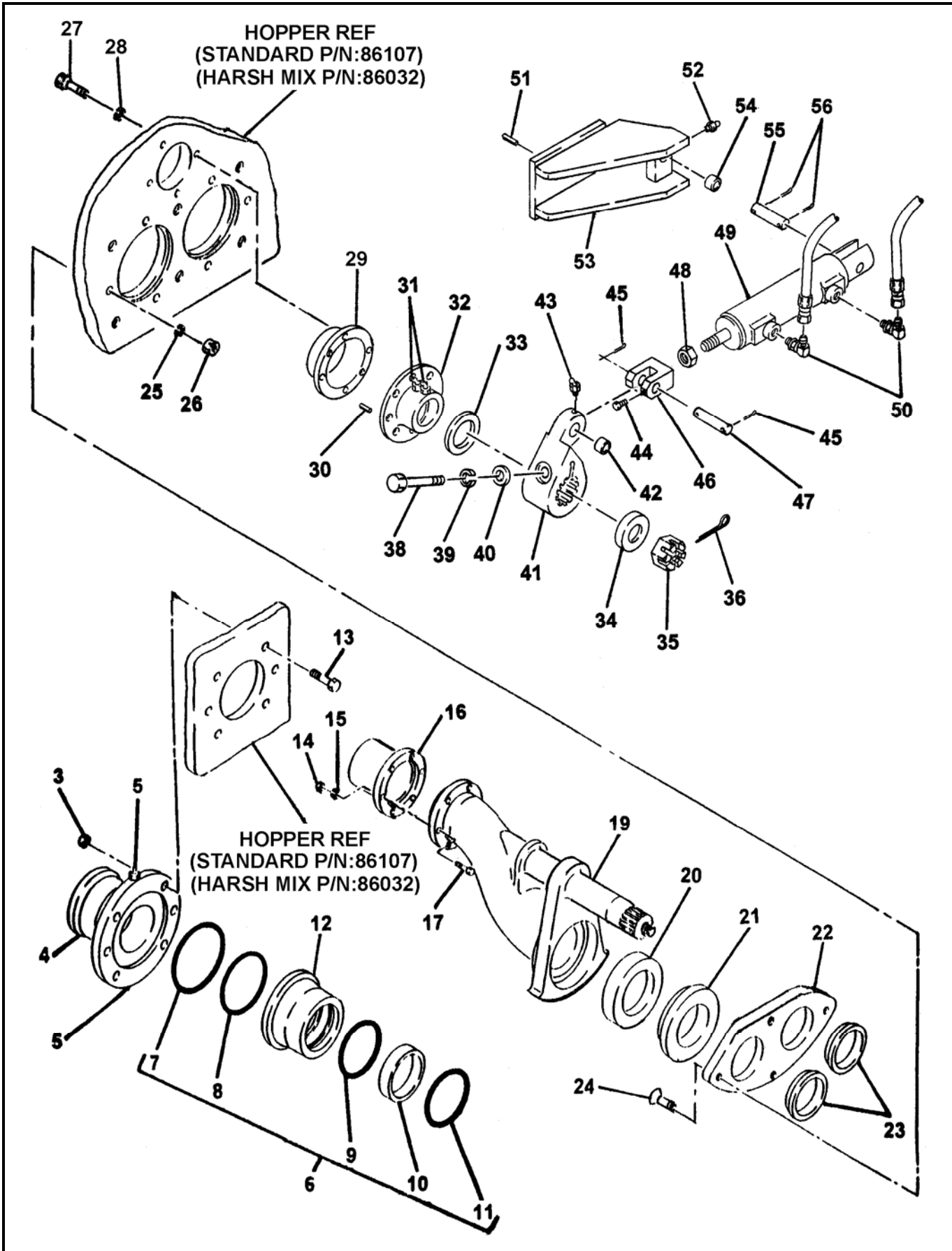

REVISION:





# SINGLE SHIFT SWING VALVE ASSEMBLY

**B60**  
**PARTS**  
GROUP 60  
FIGURE 03  
PAGE 02

ITEM NO.	REED'S PARTS NO.	DESCRIPTION	QTY
		1 2 3 4 5	
-1	60-03	Assembly, Single Shift Swing Valve (See Group 60, Figure 01 for NHA)	Ref
-2	86321	• Assembly, Outlet Group	1
3		•• Nut	6
4	72482	•• Outlet, Machine 5"	1
5		•• Fitting, Grease	2
6	79895	•• Kit, Outlet Seal	1
7	77761	••• O-Ring, Large	1
8	77762	••• O-Ring, Small	1
9	86504	••• Seal, Modified Outlet Thick	1
10	77763	••• Band, Guide	1
11	77765	••• Seal, Outlet Thick	1
12	72309	•• Housing, Outlet Seal	1
13		•• Bolt, Hex	6
14		•• Nut, Nylock (attaching parts)	6
15		•• Washer, Lock (attaching parts)	6
16	70042	•• Outlet, Chromed	1
17		•• Bolt, Hex (attaching parts)	6
-18	86317	• Assembly, Swing Tube Group	1
19	85965	•• Weldment, Harsh Swing Tube	1
20	86065	•• Seal, 6 Inch Single Lip	1
21	72310	•• Ring, 6 Inch Single Lip Wear	1
22	86031	•• Plate, Wear	1
23	86086	•• Ring, Anti Chip	2
24		•• Bolt, Flat Head	4
25		•• Washer, Lock	4
26		•• Nut, Hex	4
27		•• Bolt, Hex	6
28		•• Washer, Lock	6
29	85962	•• Seal, Flange Bearing	1
30		•• Pin, Dowel	1
31		•• Fitting, Grease 90	2
32	85133	•• Bearing, 3 Inch Spline Flange	1
33	85294	•• Washer, Thrust	1
34	85134	•• Spacer, Swing Tube Nut	1
35	70825	•• Nut, Swing Tube	1
36		•• Pin Cotter	1
-37	86319	• Assembly, Swing Tube Single Shift Group	1
38		•• Bolt, Hex	1
39		•• Washer, Flat	1
40		•• Washer, Lock	1
41	85131	•• Crank, 3 Inch Single Splined Bell	1

DASH (-) ITEM NOT ILLUSTRATED

REVISION:



# SINGLE SHIFT SWING VALVE ASSEMBLY

**B60**  
**PARTS**  
GROUP 60  
FIGURE 03  
PAGE 03

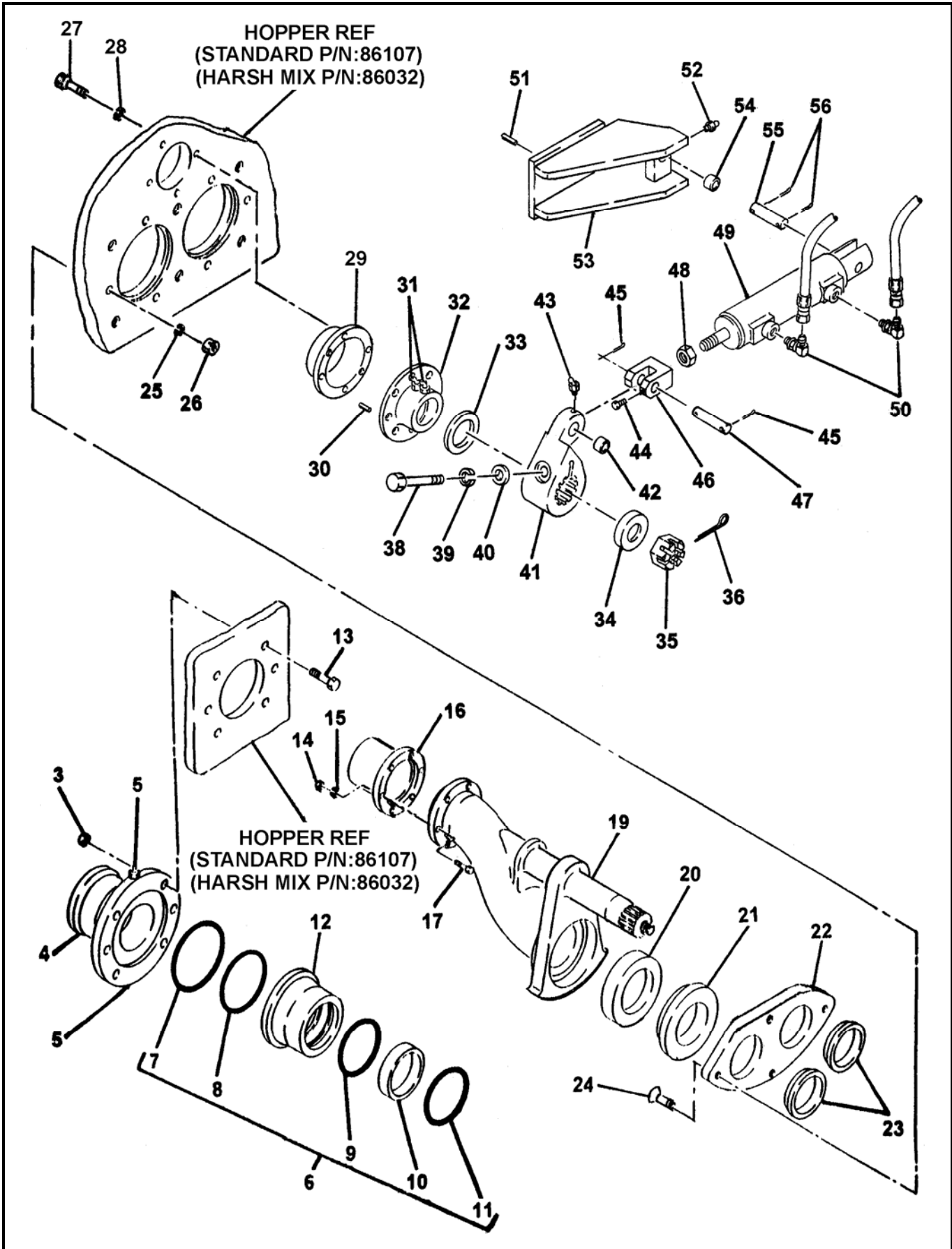

REVISION:



# SINGLE SHIFT SWING VALVE ASSEMBLY

**B60**  
**PARTS**  
GROUP 60  
FIGURE 03  
PAGE 04

ITEM NO.	REED'S PARTS NO.	DESCRIPTION					QTY
		1	2	3	4	5	
42	85538	•••	Race, Inner				1
43		••	Fitting, Grease 90				1
44		••	Bolt, Hex				1
45		••	Pin, Cotter				2
46	86135	••	Clevis, Swing Ram Cylinder				1
47	86150	••	Pin, Clevis				1
48		••	Nut, Hex				1
49	86221	••	Assembly, Single Shift Swing Ram Cylinder (See Group 60, Figure 05 for DET)				1
50		••	Fitting, 90				2
51	86052	••	Pin, Spring				2
52		••	Fitting, Grease STR				1
53	85947	••	Bracket, Single Shift Swing Cylinder				1
54	71011	•••	Bushing, Shift Cylinder				1
55	74207	••	Pin, Clevis				1
56		••	Pin, Cotter				2

DASH (-) ITEM NOT ILLUSTRATED

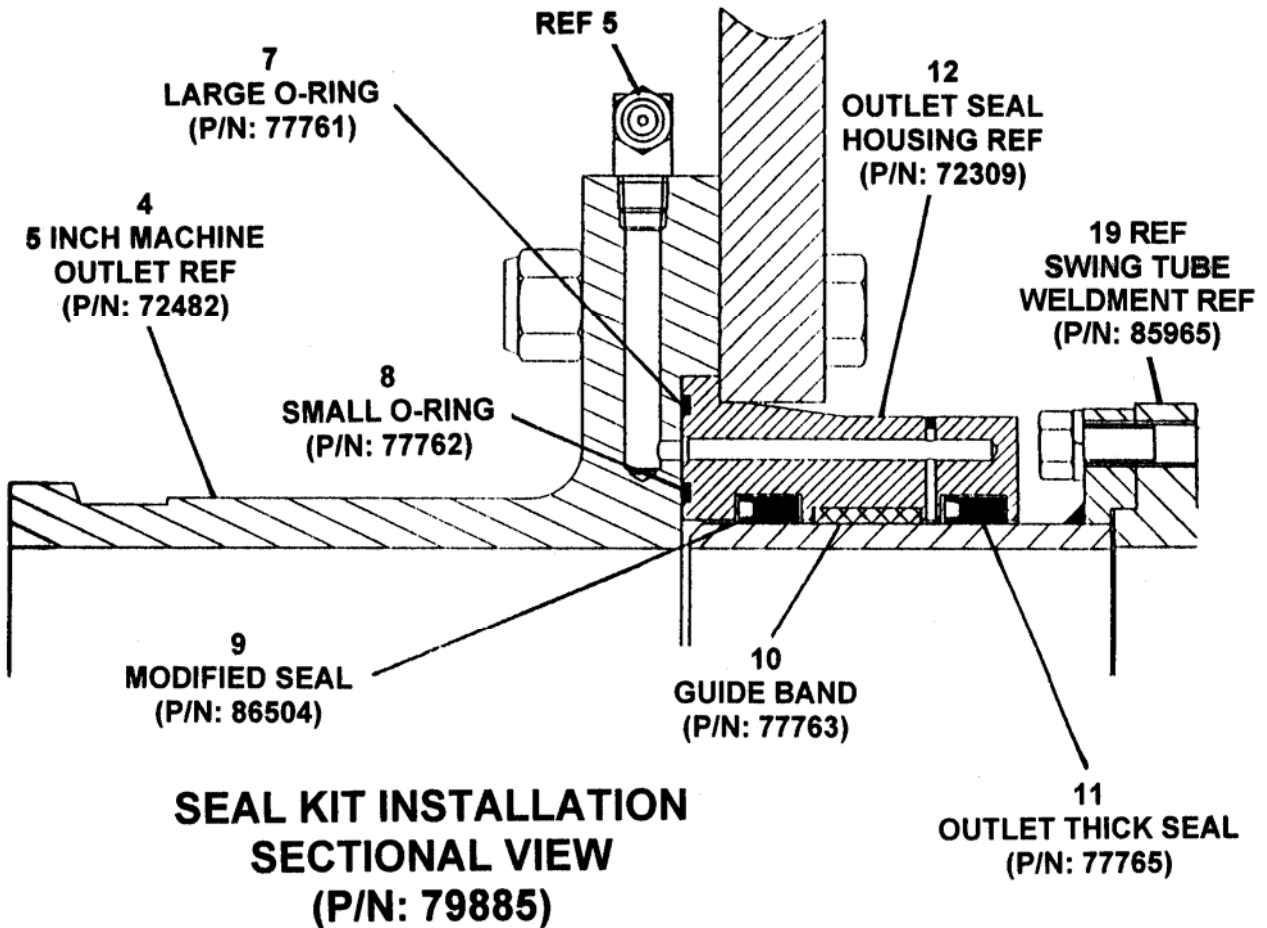

REVISION:



# DUAL SHIFT SWING VALVE ASSEMBLY

**B60**  
**PARTS**  
GROUP 60  
FIGURE 04  
PAGE 01

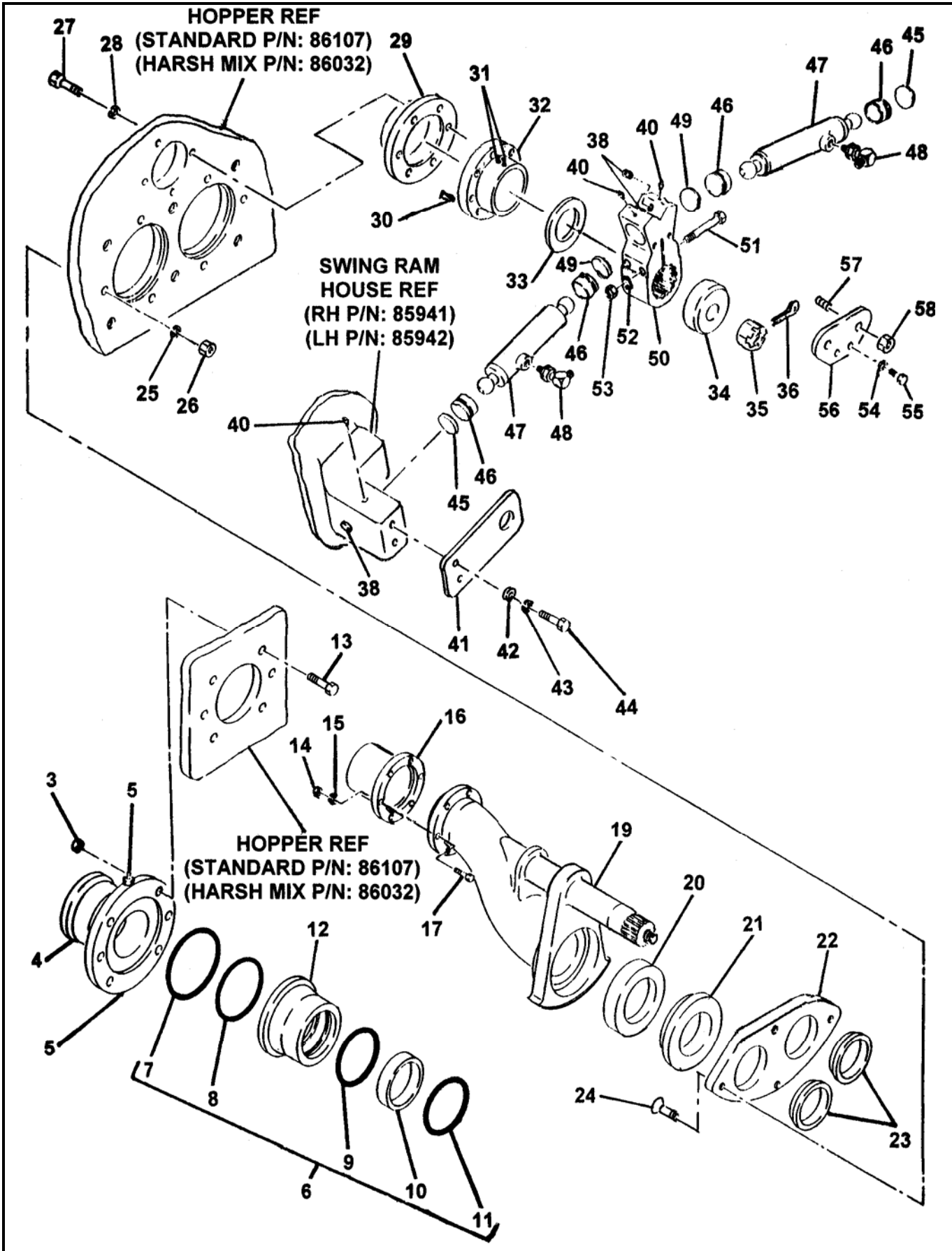

REVISION:



# DUAL SHIFT SWING VALVE ASSEMBLY

**B60**  
**PARTS**  
GROUP 60  
FIGURE 04  
PAGE 02

ITEM NO.	REED'S PARTS NO.	DESCRIPTION					QTY
		1	2	3	4	5	
-1	60-04	Assembly, Dual Shift Swing Valve (See Group 60, Figure 02 for NHA)					Ref
-2	86321	• Assembly, Outlet Group					1
3		• • Nut					6
4	72482	• • Outlet, Machine 5"					1
5		• • Fitting, Grease					2
6	79895	• • Kit, Outlet Seal					1
7	77761	• • • O-Ring, Large					1
8	77762	• • • O-Ring, Small					1
9	86504	• • • Seal, Modified Outlet Thick					1
10	77763	• • • Band, Guide					1
11	77765	• • • Seal, Outlet Thick					1
12	72309	• • Housing, Outlet Seal					1
13		• • Bolt, Hex					6
14		• • Nut, Nylock (attaching parts)					6
15		• • Washer, Lock (attaching parts)					6
16	70042	• • Outlet, Chromed					1
17		• • Bolt, Hex (attaching parts)					6
-18	86317	• Assembly, Swing Tube Group					1
19	85965	• • Weldment, Harsh Swing Tube					1
20	86065	• • Seal, 6 Inch Single Lip					1
21	72310	• • Ring, 6 Inch Single Lip Wear					1
22	86031	• • Plate, Wear					1
23	86086	• • Ring, Anti Chip					2
24		• • Bolt, Flat Head					4
25		• • Washer, Lock					4
26		• • Nut, Hex					4
27		• • Bolt, Hex					6
28		• • Washer, Lock					6
29	85962	• • Seal, Flange Bearing					1
30		• • Pin, Dowel					1
31		• • Fitting, Grease 90					2
32	85133	• • Bearing, 3 Inch Spline Flange					1
33	85294	• • Washer, Thrust					1
34	85134	• • Spacer, Swing Tube Nut					1
35	70825	• • Nut, Swing Tube					1
36		• • Pin Cotter					1
-37	86320	• Assembly, Swing Tube Dual Shift Group					1
38		• • Plug, Pipe					4
39	86052	• • Pin, Spring					4
40		• • Fitting, Grease 90					2
41	86441	• • Retainer, Swing Ram					2

DASH (-) ITEM NOT ILLUSTRATED

REVISION:



# DUAL SHIFT SWING VALVE ASSEMBLY

**B60**  
**PARTS**  
GROUP 60  
FIGURE 04  
PAGE 03

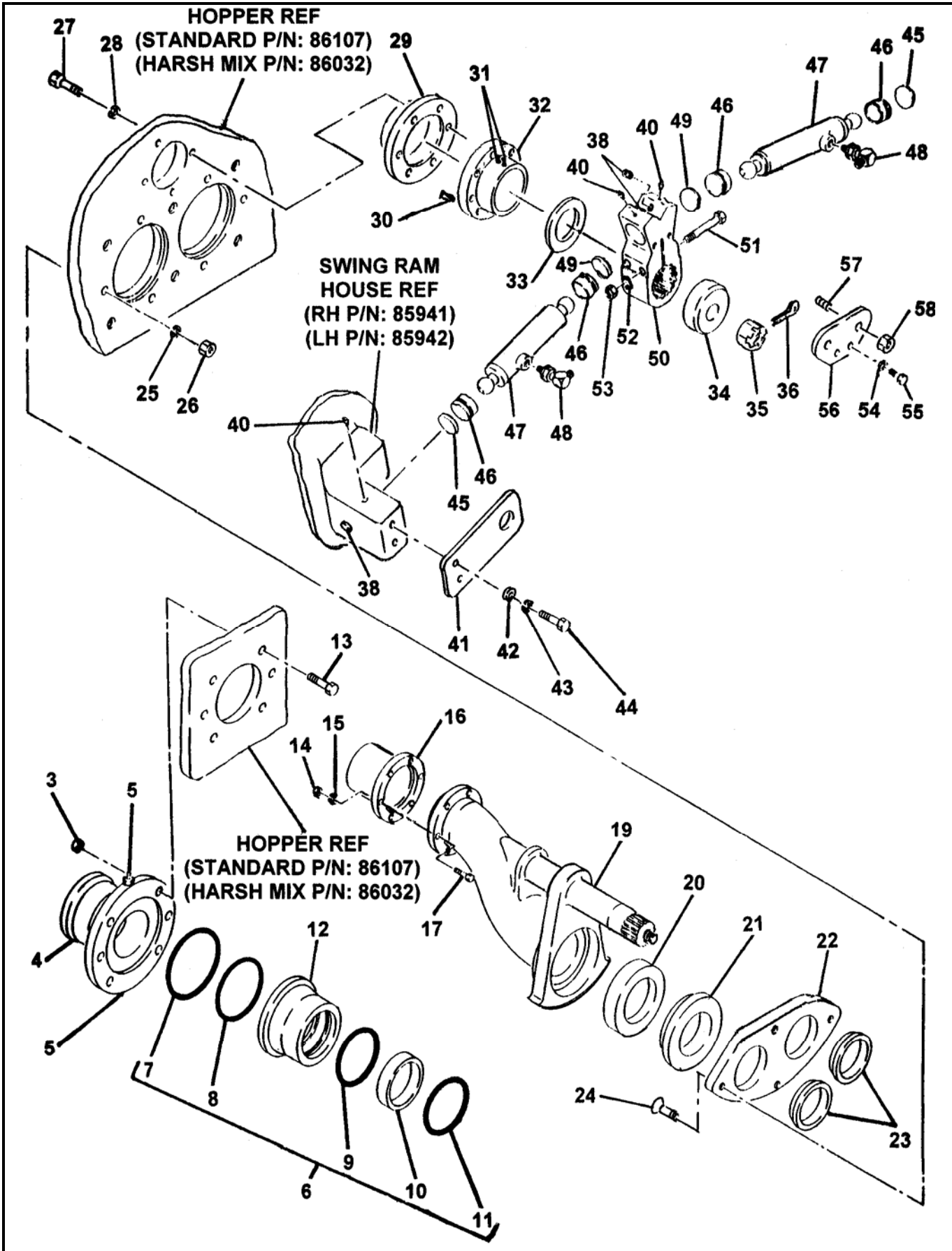

REVISION:

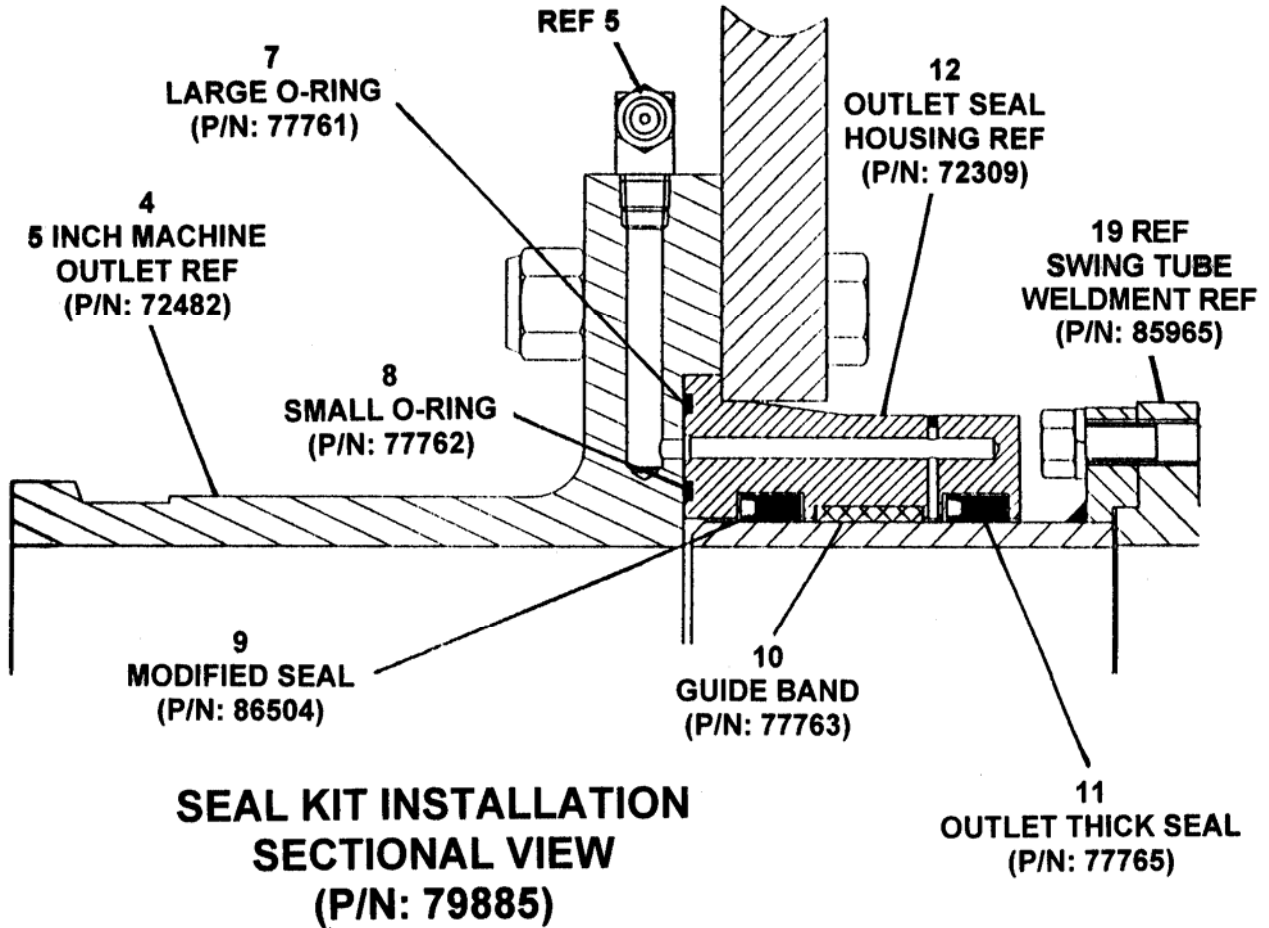

ITEM NO.	REED'S PARTS NO.	DESCRIPTION					QTY
		1	2	3	4	5	
42		••	Washer, Flat (attaching parts)				4
43		••	Washer, Lock (attaching parts)				4
44		••	Bolt, Hex (attaching parts)				4
45	75501	••	Spacer				2
46	76798	••	Socket, Ball				4
47	86220	••	Assembly, Dual Shift Swing Ram Cylinder (See Group 60, Figure 06 for DET)				1
48	75502	••	Fitting, 90				2
49	75501	••	Spacer				2
50	85956	••	Crank, 3 Inch Dual Shift Splined Bell				1
51		••	Bolt, Hex (attaching parts)				2
52		••	Washer, SPL Lock (attaching parts)				2
53		••	Nut, Hex (attaching parts)				2
54		••	Washer, Lock				2
55	86283	••	Bolt, Hex				2
56	86282	••	Retainer, Dual Shift Cylinder				1
57		••	Stud				2
58		••	Nut, Hex				2

DASH (-) ITEM NOT ILLUSTRATED



# SINGLE SHIFT SWING RAM CYLINDER ASSEMBLY

**B60**  
**PARTS**  
GROUP 60  
FIGURE 05  
PAGE 01

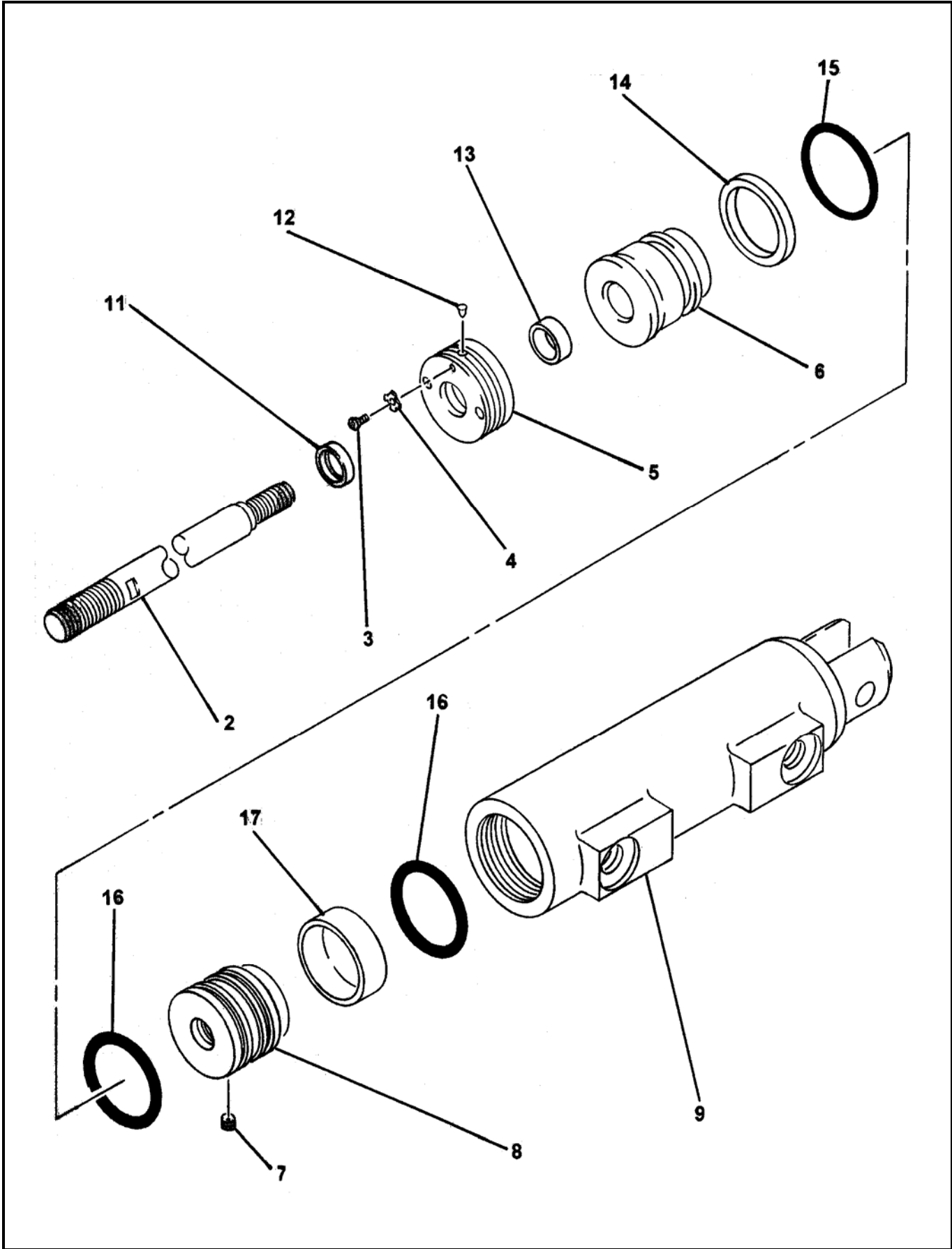

REVISION:





**SINGLE SHIFT  
SWING RAM CYLINDER ASSEMBLY**

**B60**  
**PARTS**  
GROUP 60  
FIGURE 05  
PAGE 02

ITEM NO.	REED'S PARTS NO.	DESCRIPTION	QTY
		1 2 3 4 5	
-1	86221	Assembly, Single Shift Swing Ram Cylinder (See Group 60, Figure 03 for NHA)	Ref
2		• Rod, Cylinder	1
3		• Screw, Cap	1
4		• Washer, Lock	1
5		• Ring, Threaded	1
6		• Gland, Head	1
7		• Screw, Set	1
8		• Ring, Threaded	1
9		• Weldment, Cylinder Case	1
-10	86221-SK	• Kit, Seal	1
11		• • Wiper, Rod	1
12		• • Plug, Nylon	11
13		• • U-Cup	1
14		• • Seal, Back Up	1
15		• • O-Ring	1
16		• • Seal, Piston	2
17		• • Ring, Wear	1

DASH (-) ITEM NOT ILLUSTRATED



DUAL SHIFT  
SWING RAM CYLINDER ASSEMBLY

**B60**  
**PARTS**  
GROUP 60  
FIGURE 06  
PAGE 01

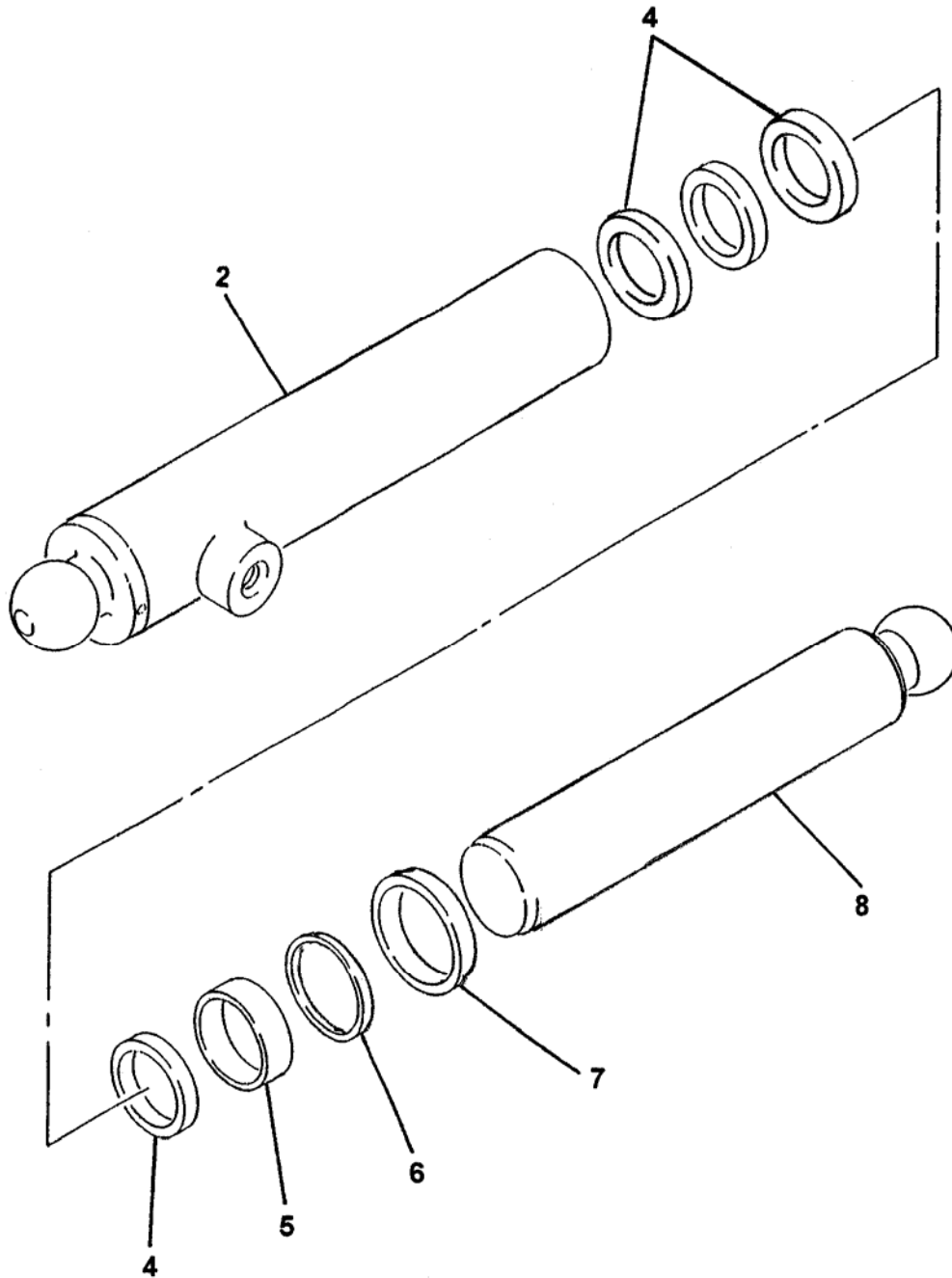

REVISION:



**DUAL SHIFT  
SWING RAM CYLINDER ASSEMBLY**

**B60**  
**PARTS**  
GROUP 60  
FIGURE 06  
PAGE 02

ITEM NO.	REED'S PARTS NO.	DESCRIPTION	QTY
		1 2 3 4 5	
-1	86220	Assembly, Swing Ram Cylinder (See Group 60, Figure 04 for NHA)	Ref
2		• Weldment, Cylinder Case	1
-3	86220-SK	• Kit, Seal	1
4		• • Ring, Wear	1
5		• • U-Cup	1
6		• • Ring, Back Up	4
7		• • Wiper, Rod	1
8		• Weldment, Cylinder Rod	1

DASH (-) ITEM NOT ILLUSTRATED



# MATERIAL CYLINDER ASSEMBLY

**B60**  
**PARTS**  
GROUP 60  
FIGURE 07  
PAGE 01

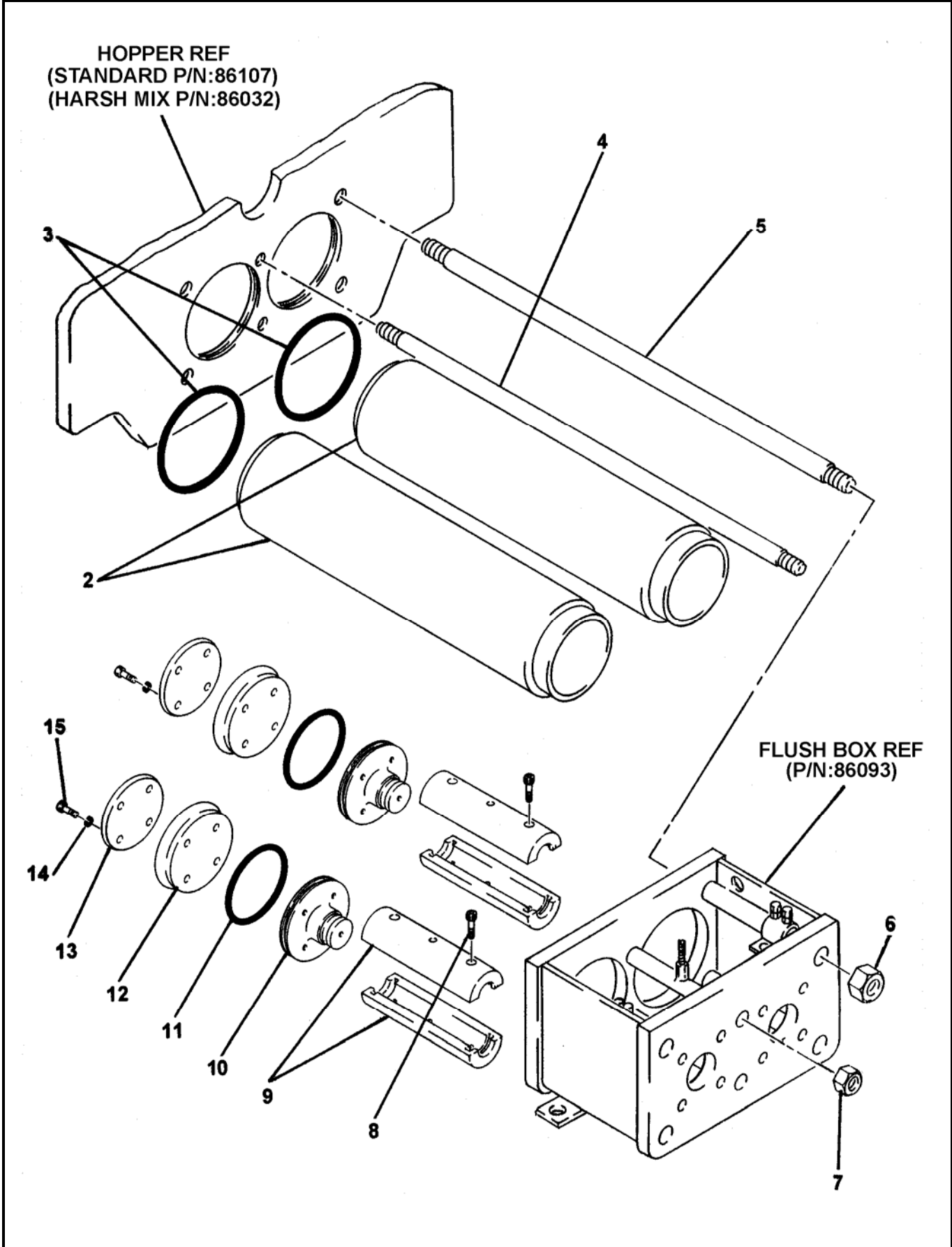

REVISION:



# MATERIAL CYLINDER ASSEMBLY

**B60**  
**PARTS**  
GROUP 60  
FIGURE 07  
PAGE 02

ITEM NO.	REED'S PARTS NO.	DESCRIPTION	QTY
		1 2 3 4 5	
-1	86309	Assembly, Material Cylinder (See Group 60, Figure 01 and Figure 02 for NHA)	Ref
2	86148	• Cylinder, Material	2
3	86149	• O-Ring, Material Cylinder	2
4	86047	• Rod, Tie	2
5	86046	• Rod, Tie	4
6		• Nut, Hex (attaching Parts)	4
7		• Nut, Hex (attaching Parts)	2
8		• Screw, Cap	4
9	86101	• Coupling, Piston	2
10	77194	• Adapter, 6 Inch Piston	2
11	77120	• Ring, 6 Inch Wear	2
12	70048	• Cup, 6 Inch Piston	2
13	70057	• Plate, 6 Inch Piston	2
14		• Washer, Star (attaching Parts)	8
15		• Bolt, Hex (attaching Parts)	8

DASH (-) ITEM NOT ILLUSTRATED



# FLUSH BOX ASSEMBLY

**B60**  
**PARTS**  
GROUP 60  
FIGURE 08  
PAGE 01

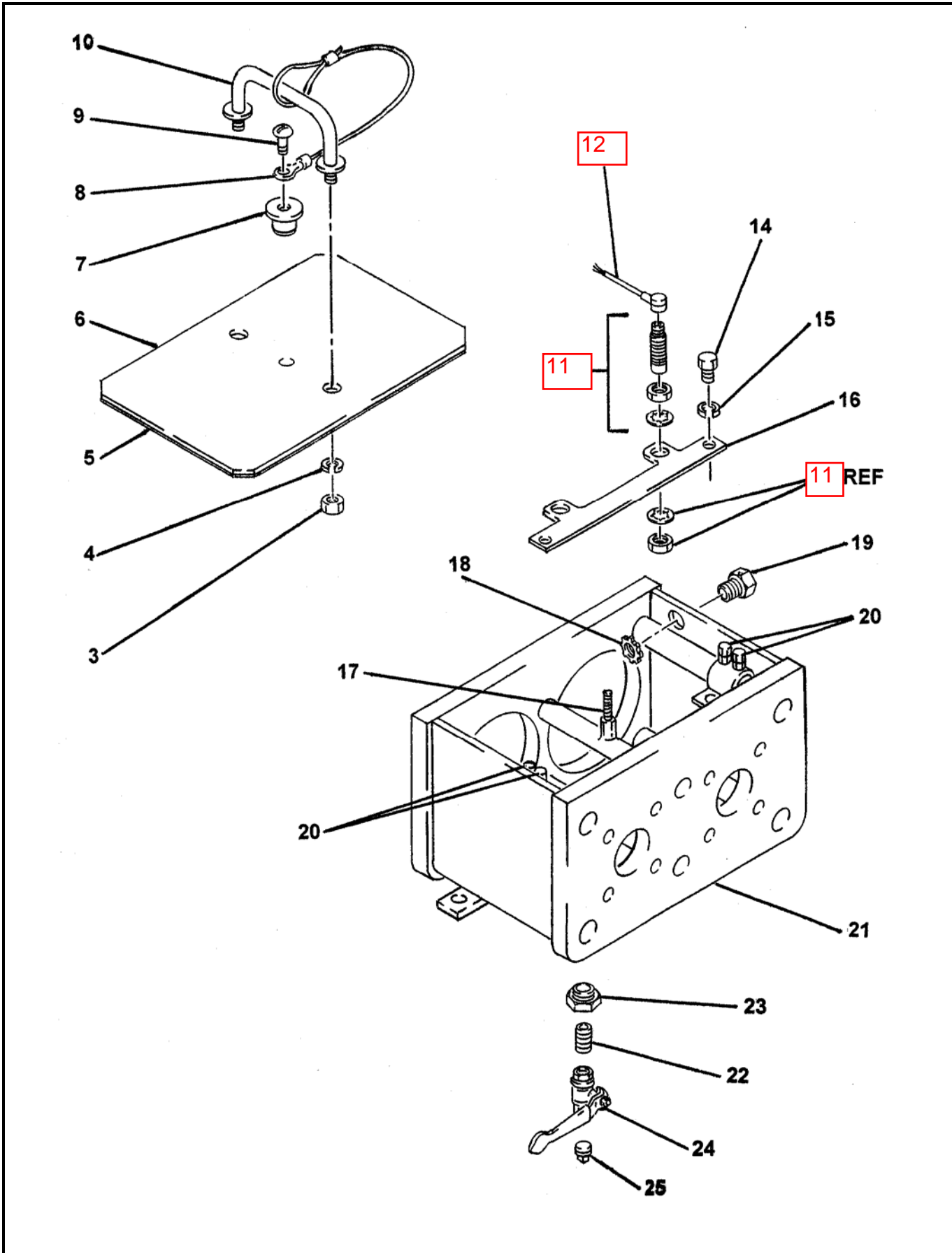

REVISION:



# FLUSH BOX ASSEMBLY

**B60**  
**PARTS**  
GROUP 60  
FIGURE 08  
PAGE 02

ITEM NO.	REED'S PARTS NO.	DESCRIPTION	QTY
		1 2 3 4 5	
-1	60-08	Assembly, Flushbox (See Group 60, Figure 01 and Figure 02 for NHA)	Ref
-2	86106	• Assembly, Flush Box Cover	1
3		• • Nut, Hex	2
4		• • Washer, Lock	2
5	13257	• • Weatherstrip, Rubber	A/R
6	86010	• • Weldment, Flush Box Cover	1
7	86105	• • Knob	1
8	800418	• • Lanyard	1
9		• • Screw, Round Head	1
10	79056	• • Handle, Splash Guard	1
11	77998	• Sensor, Proximity Switch	2
12	77990	• Cable, Proximity Switch	2
-13	86307	• Assembly, 6 Inch Flush Box Group	1
14		• • Bolt, Hex	2
15		• • Washer, Lock	2
16	86006	• • Bracket, Proximity Switch	1
17	86665	• • Stud	1
18	10528	• • Nut	1
19	73783	• • Conduit, Fitting	1
20		• • Bolt, Hex	4
21	86093	• • Weldment, Flush Box	1
22	10224	• Bushing, Hex	1
23	10355	• Nipple	1
24	56413	• Valve, Ball	1
25	74944	• Plug	1

DASH (-) ITEM NOT ILLUSTRATED



# HYDRAULIC DRIVE CYLINDER ASSEMBLY

**B60**  
**PARTS**  
GROUP 60  
FIGURE 09  
PAGE 01

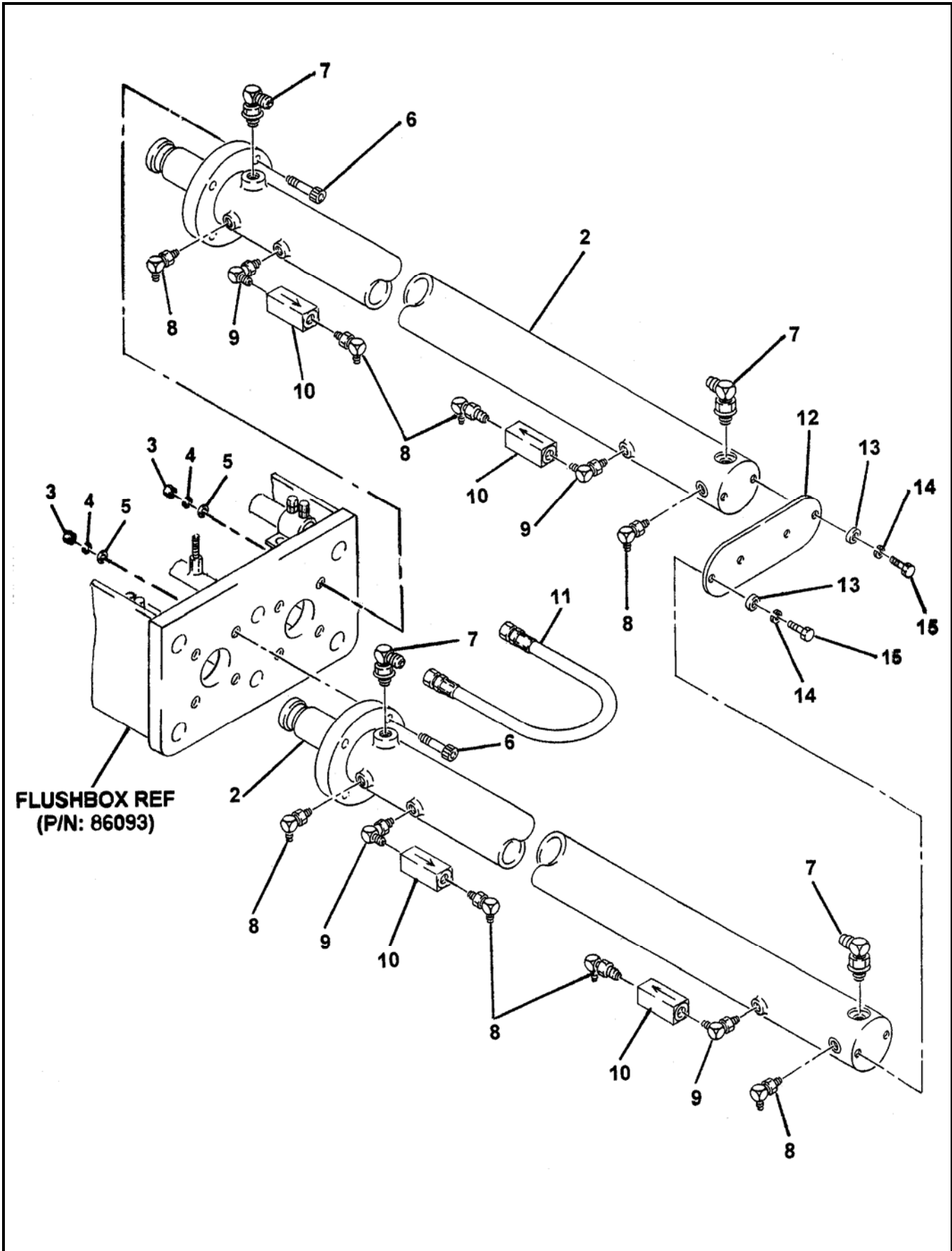

REVISION:





# HYDRAULIC DRIVE CYLINDER ASSEMBLY

**B60**  
**PARTS**  
GROUP 60  
FIGURE 09  
PAGE 02

ITEM NO.	REED'S PARTS NO.	DESCRIPTION	QTY
		1 2 3 4 5	
-1	86303	Assembly, Hydraulic Drive Cylinder (See Group 60, Figure 01 and Figure 02 for NHA)	Ref
2	86224	• Assembly, Drive Cylinder (See Group 60, Figure 10 for DET)	1
3		• Nut, Hex (attaching parts)	8
4		• Washer, Lock (attaching parts)	8
5	77396	• Washer, Thread (attaching parts)	8
6		• Bolt (attaching parts)	8
7		• Fitting, 90	4
8		• Fitting, 90	8
9		• Fitting, 90	4
10	78961	• Valve, Check	4
11	85427	• Assembly, Tube	1
12	86544	• Plate, End	1
13		• Washer, Flat (attaching parts)	4
14		• Washer, Lock (attaching parts)	4
15		• Bolt, Hex (attaching parts)	4

REVISION:



# DRIVE CYLINDER ASSEMBLY

**B60**  
**PARTS**  
GROUP 60  
FIGURE 10  
PAGE 01

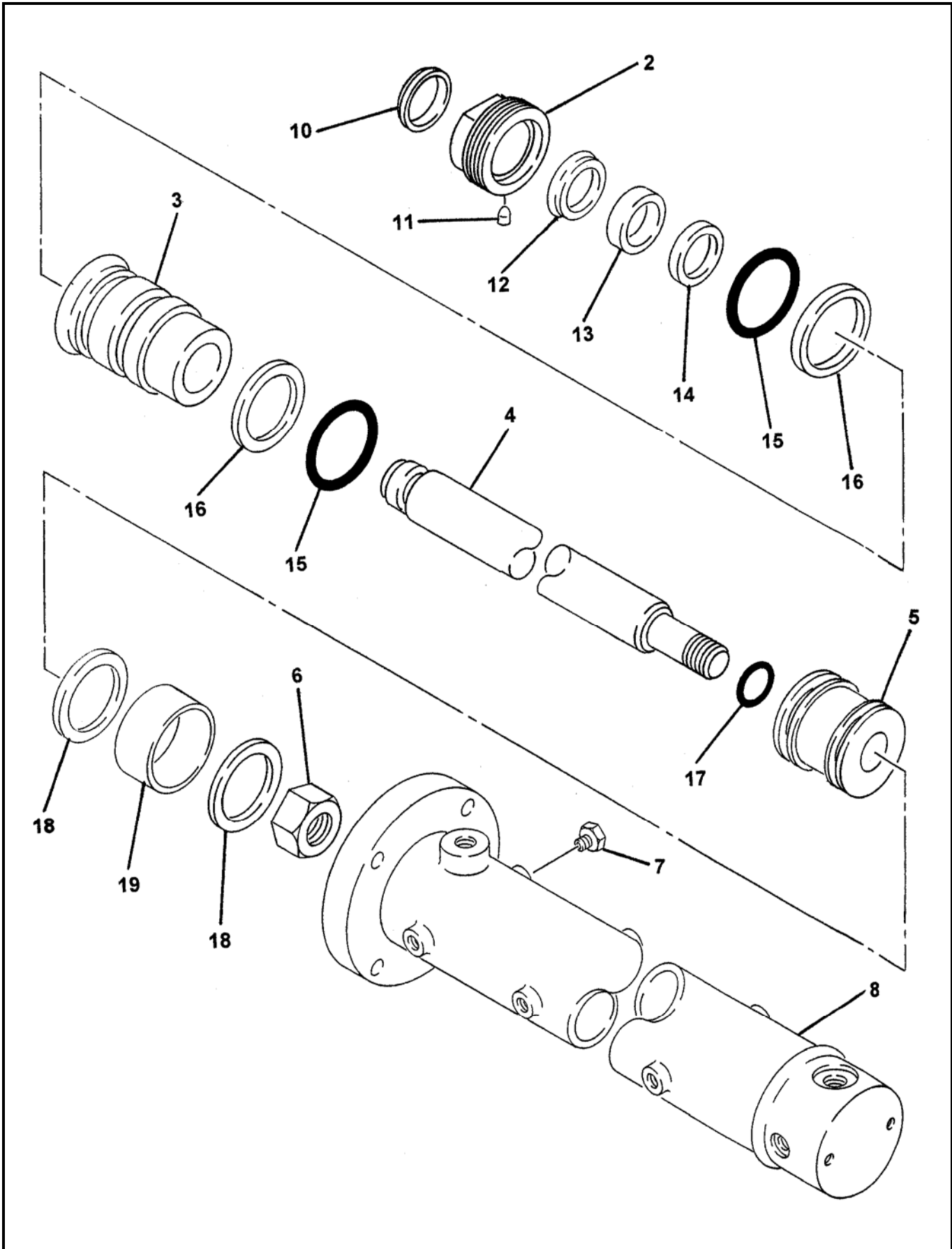

REVISION:



# DRIVE CYLINDER ASSEMBLY

**B60**  
**PARTS**  
GROUP 60  
FIGURE 10  
PAGE 02

ITEM NO.	REED'S PARTS NO.	DESCRIPTION	QTY
		1 2 3 4 5	
-1	86224	Assembly, Drive Cylinder (See Group 60, Figure 09 for NHA)	Ref
2		• Ring, Threaded	1
3		• Gland, Head	1
4		• Rod, Cylinder	1
5		• Piston	1
6		• Nut, Piston	1
7		• Plug	4
8		• Weldment, Cylinder Case	1
-9	86224-SK	• Kit, Seal	1
10		•• Wiper, Rod	1
11		•• Plug, Nylon	1
12		•• Ring, Back Up	1
13		•• U-Cup	1
14		•• Seal, Buffer	1
15		•• O-Ring	2
16		•• Ring, Back Up	2
17		•• O-Ring	1
18		•• Seal, Piston	2
19		•• Ring, Wear	1

REVISION:

**REED**

**TRAILER MOUNTED PUMP MODEL *B60*  
ILLUSTRATED PARTS MANUAL**

***B60***  
**PARTS**  
GROUP 60  
FIGURE 11  
PAGE 01

THIS PAGE INTENTIONALLY LEFT BLANK.

REVISION:

**REED TRAILER MOUNTED CONCRETE PUMP 01 MODEL B60 ILLUSTRATED PARTS MANUAL GROUP 70 FRAME INSTALLATION CONTAINS THE FOLLOWING FIGURES:**

- FIGURE 00** TABLE OF CONTENTS
- FIGURE 01** FRAME INSTALLATION
- FIGURE 02** HUB AND BRAKE ASSEMBLY
- FIGURE 03** NON-OPERATOR SIDE ELECTRIC BRAKE ASSEMBLY
- FIGURE 04** OPERATOR SIDE ELECTRIC BRAKE ASSEMBLY





# FRAME INSTALLATION

B60  
PARTS  
GROUP 70  
FIGURE 01  
PAGE 01

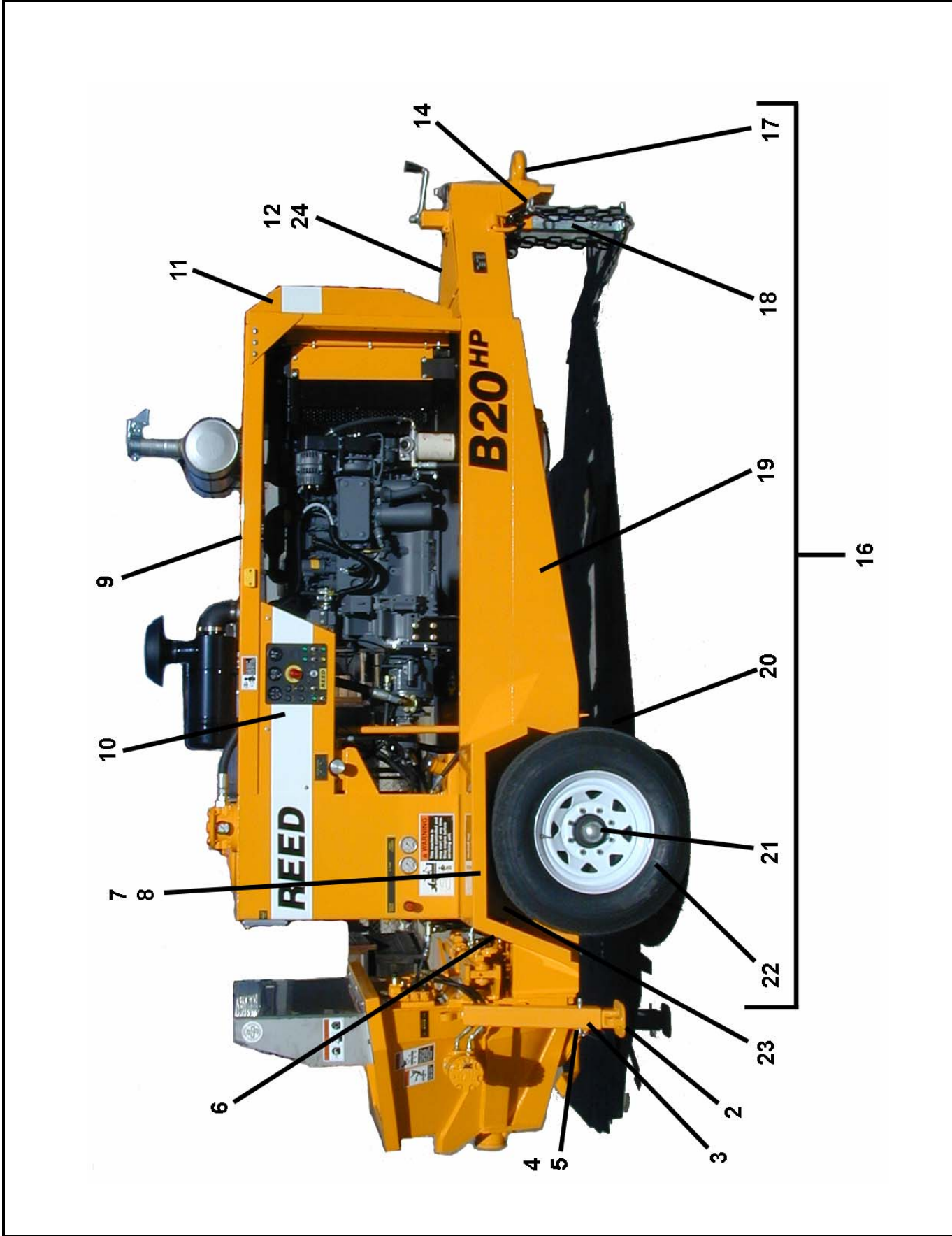

REVISION:



# FRAME INSTALLATION

**B60**  
**PARTS**  
GROUP 70  
FIGURE 01  
PAGE 02

ITEM NO.	REED'S PARTS NO.	DESCRIPTION	QTY
		1 2 3 4 5	
-1	70-01 87175	Installation, Frame (See Group 10, Figure 01, 02, 03 and 04 for NHA)	Ref
2	86553	• Weldment, Outrigger Inner	2
3	86557	• Weldment, Outrigger Outer Tube	2
4	85595	• Pin, Outrigger Safety	2
5	800418	• Lanyard, Q/R Pin	2
6	72948	• Light, Tail	2
7	86959	• Weldment, Right Fender	1
8	86960	• Weldment, Left Fender	1
9	87129	• Assembly, Top Panel	1
10	85391	• Cover, Control Box	1
11	87141	• Cover, Front	1
12	85338	• Cover, Tool Box	1
13	86533	• Assembly, Trailer Wiring Harness (See Schematic Section, Page 15 for REF)	1
14	87085	• Anchor, Shackle	2
15	86730	• Chain, 3/8 Proof Coil -6 FT	2
16	87216	• Assembly, Frame B20	1
17	87037	• • Draw Bar	1
18	85527	• • Weldment, Jack	1
19	87135	• • Weldment, Frame B60	1
20	86924	• • Axle-9000 Lbs	1
21	70-02	• • Assembly, Hub and Brake-See Figure 02	1
22	86923	• • Assembly, Wheel and Tire	2
23	72949	• Grommet, Trailer	3
24	72813	• Grommet, Tool Box	1

DASH (-) ITEM NOT ILLUSTRATED

REVISION:



# HUB AND BRAKE ASSEMBLY

B60  
PARTS  
GROUP 70  
FIGURE 02  
PAGE 01

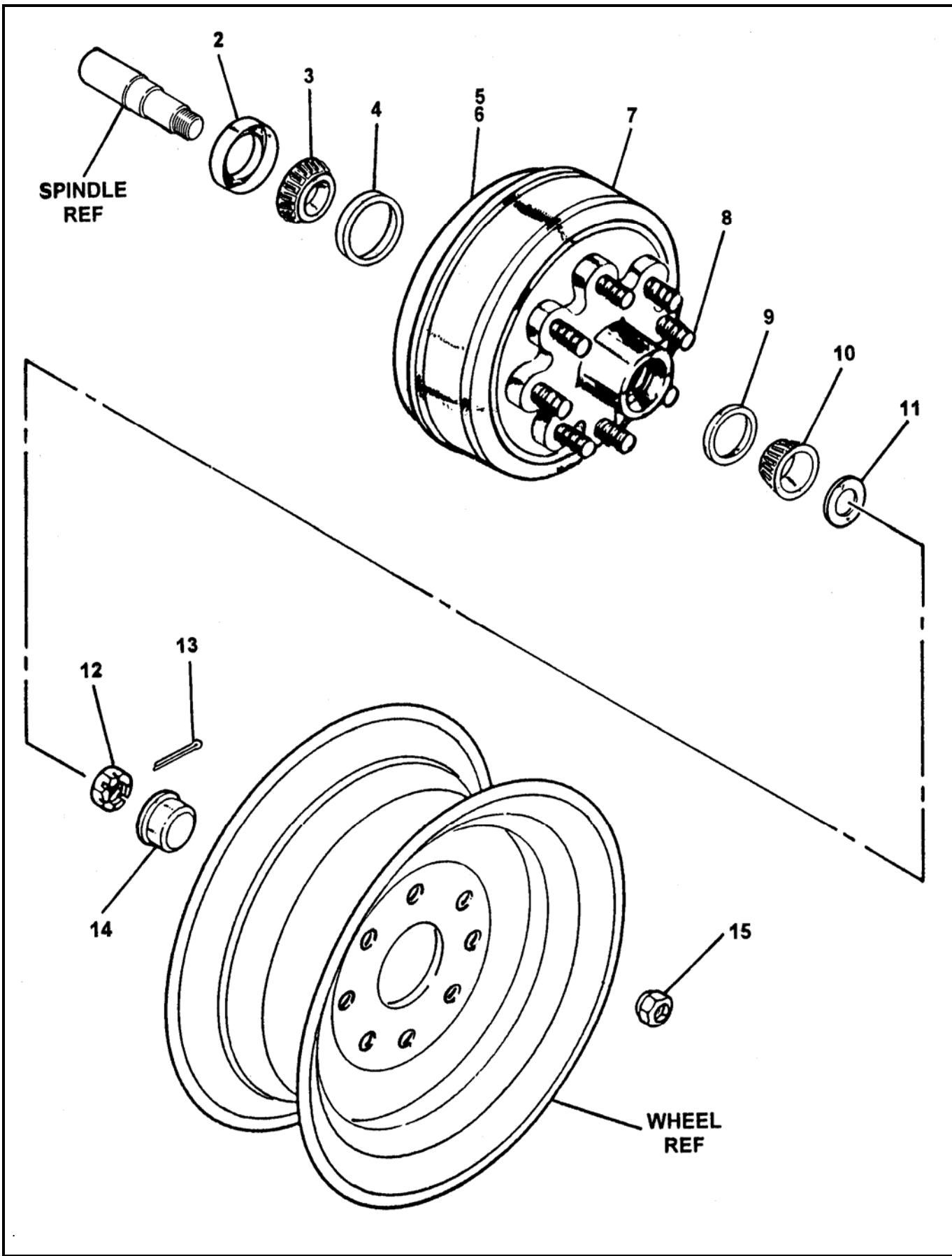

REVISION:





# HUB AND BRAKE ASSEMBLY

B60  
**PARTS**  
GROUP 70  
FIGURE 02  
PAGE 02

ITEM NO.	REED'S PARTS NO.	DESCRIPTION	QTY
		1 2 3 4 5	
-1	70-02	Assembly, Hub and Brake (Left And Right Side) (See Group 70, Figure 01 for NHA)	Ref
2	86709	• Seal, Double Lip Grease	2
3	71094	• Bearing, Inner	2
4	71092	• Race, Inner Bearing	2
5	71056-L	• Assembly, Non-Operator Side Electric Brake (Set) (See Group 70, Figure 03 for DET)	1
6	71056-R	• Assembly, Operator Side Electric Brake (Set) (See Group 70, Figure 04 for DET)	1
7	86717	• Assembly, Drum And Hub	2
8	86716	• Stud, Wheel	16
9	86710	• Race, Outer Bearing	2
10	71098	• Bearing, Outer	2
11	86711	• Washer, Spindle	2
12	86712	• Nut, Spindle	2
13	86713	• Pin, Cotter	2
14	86714	• Cap, Dust	2
15	86715	• Nut, Wheel	16

DASH (-) ITEM NOT ILLUSTRATED



# NON OPERATOR SIDE ELECTRIC BRAKE ASSEMBLY

B60  
PARTS  
GROUP 70  
FIGURE 03  
PAGE 01

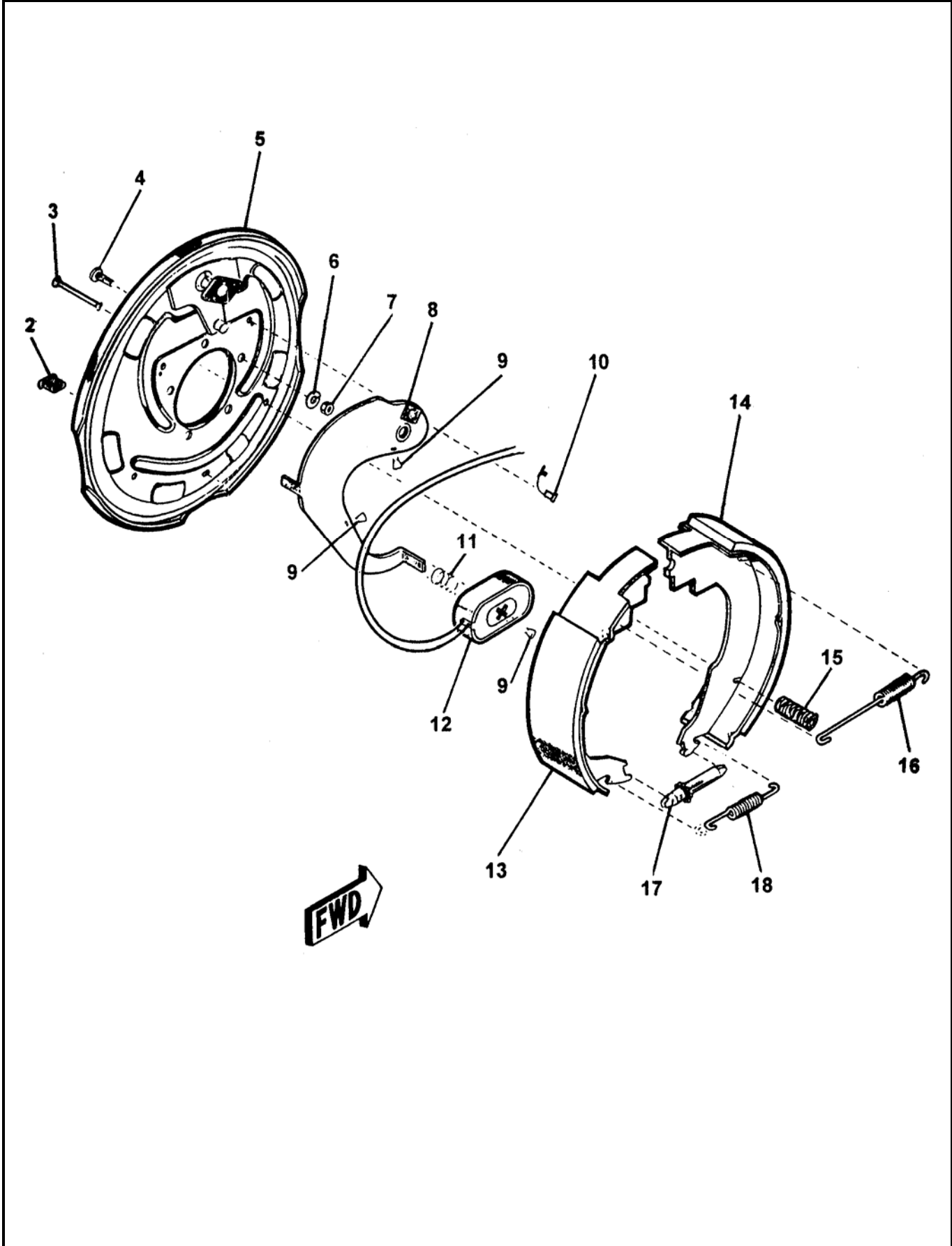

REVISION:



# NON OPERATOR SIDE ELECTRIC BRAKE ASSEMBLY

B60  
**PARTS**  
GROUP 70  
FIGURE 03  
PAGE 02

ITEM NO.	REED'S PARTS NO.	DESCRIPTION	QTY
		1 2 3 4 5	
-1	71056-L	Assembly, Non-Operator Side Electric Brake (See Group 70, Figure 02 for NHA)	Ref
2		• Slot, Plug Adjust	1
3		• Pin, Shoe Hold down	1
4		• Stud, Brake Mounting	5
5		• Assembly, Baking Plate	1
6		• Washer, Brake Lock	5
7		• Nut, Brake Mounting	5
8		• Lever, Non-Operator Side	1
9		• Clip, Wire and Magnet	3
10		• Relief, Strain	2
11		• Spring, Magnet	1
12		• Sub-Assembly, Magnet	1
13		• Shoe and Lining, Primary	1
14		• Shoe and Lining, Secondary	1
15		• Spring, Shoe Hold down	1
16		• Spring, Shoe Retractor	1
17		• Sub-Assembly, Adjuster Screw	1
18		• Spring, Adjuster Screw	1

DASH (-) ITEM NOT ILLUSTRATED

REVISION:



# OPERATOR SIDE ELECTRIC BRAKE ASSEMBLY

B60  
PARTS  
GROUP 70  
FIGURE 04  
PAGE 01

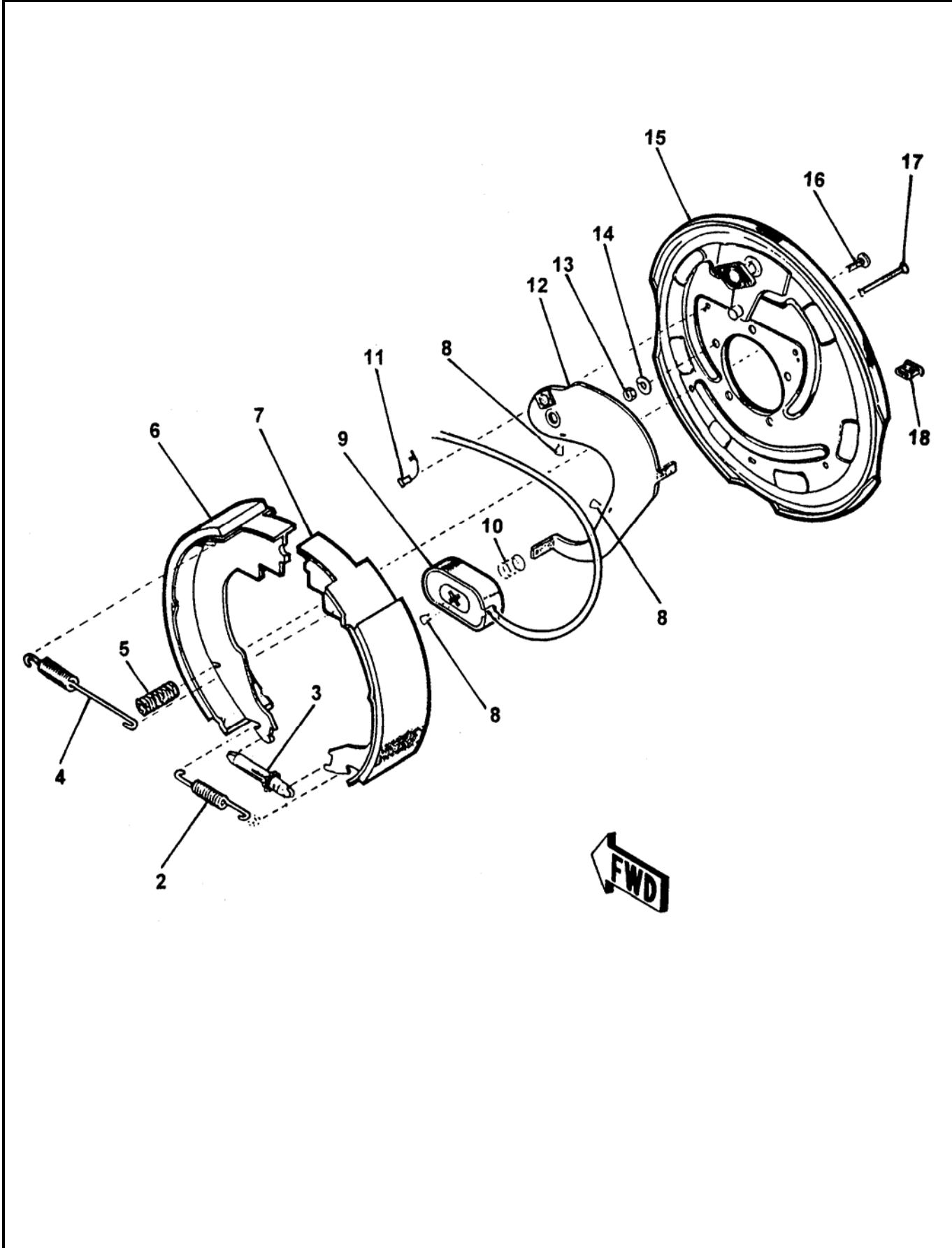

REVISION:



**OPERATOR SIDE  
ELECTRIC BRAKE ASSEMBLY**

**B60**  
**PARTS**  
GROUP 70  
FIGURE 04  
PAGE 02

ITEM NO.	REED'S PARTS NO.	DESCRIPTION					QTY
		1	2	3	4	5	
-1	71056-R	Assembly, Operator Side Electric Brake (See Group 70, Figure 02 for NHA)					Ref
2		• Spring, Adjuster Screw					1
3		• Sub-Assembly, Adjuster Screw					1
4		• Spring, Shoe Retractor					1
5		• Spring, Shoe Hold down					1
6		• Shoe and Lining, Secondary					1
7		• Shoe and Lining, Primary					1
8		• Clip, Wire and Magnet					3
9		• Sub-Assembly, Magnet					1
10		• Spring, Magnet					1
11		• Relief, Strain					2
12		• Lever, Operator Side					1
13		• Nut, Brake Mounting					5
14		• Washer, Brake Lock					5
15		• Assembly, Baking Plate					1
16		• Stud, Brake Mounting					5
17		• Pin, Shoe Hold down					1
18		• Slot, Plug Adjust					1

DASH (-) ITEM NOT ILLUSTRATED

REVISION:



TRAILER MOUNTED PUMP MODEL *B60*  
ILLUSTRATED PARTS MANUAL

*B60*  
**PARTS**  
GROUP 70  
FIGURE 05  
PAGE 01

THIS PAGE INTENTIONALLY LEFT BLANK.



**REED** TRAILER MOUNTED CONCRETE PUMP 01 MODEL **B60** ILLUSTRATED PARTS MANUAL GROUP 80 OPTIONAL INSTALLATION CONTAINS THE FOLLOWING FIGURES:

<b>FIGURE 00</b>	TABLE OF CONTENTS
<b>FIGURE 01</b>	OPTIONAL INSTALLATION
<b>FIGURE 02</b>	LUBE SYSTEM ASSEMBLY
<b>FIGURE 03</b>	12 VOLT LUBE PUMP ASSEMBLY
<b>FIGURE 04</b>	HOPPER VIBRATOR ASSEMBLY
<b>FIGURE 05</b>	THROTTLE SOLENOID ASSEMBLY
<b>FIGURE 06</b>	ACCUMULATOR CHARGE KIT
<b>FIGURE 07</b>	OPTIONAL TOOL KIT ASSEMBLY
<b>FIGURE 08</b>	ACTUATOR BRAKES ASSEMBLY
<b>FIGURE 09</b>	WATER PUMP INSTALLATION
<b>FIGURE 10</b>	WATER PUMP CONTROL VALVE ASSEMBLY
<b>FIGURE 11</b>	WATER PUMP MOTOR ASSEMBLY
<b>FIGURE 12</b>	WATER PUMP ASSEMBLY
<b>FIGURE 13</b>	NON-OPERATOR SIDE HYDRAULIC BRAKE ASSEMBLY
<b>FIGURE 14</b>	OPERATOR SIDE HYDRAULIC BRAKE ASSEMBLY
<b>FIGURE 15</b>	HYDRAULIC OUTRIGGER CYLINDER ASSEMBLY
<b>FIGURE 16</b>	1 SPOOL CONTROL VALVE ASSEMBLY
<b>FIGURE 17</b>	1 SPOOL CONTROL VALVE SUB-ASSEMBLY
<b>FIGURE 18</b>	2 SPOOL CONTROL VALVE ASSEMBLY
<b>FIGURE 19</b>	2 SPOOL CONTROL VALVE SUB-ASSEMBLY
<b>FIGURE 20</b>	SIDE DOOR ASSEMBLY
<b>FIGURE 21</b>	50 FEET STROKE COUNTER REMOTE CONTROLLER
<b>FIGURE 22</b>	100 FEET STROKE COUNTER REMOTE CONTROLLER



# OPTIONAL INSTALLATION

B60  
PARTS  
GROUP 80  
FIGURE 01  
PAGE 01

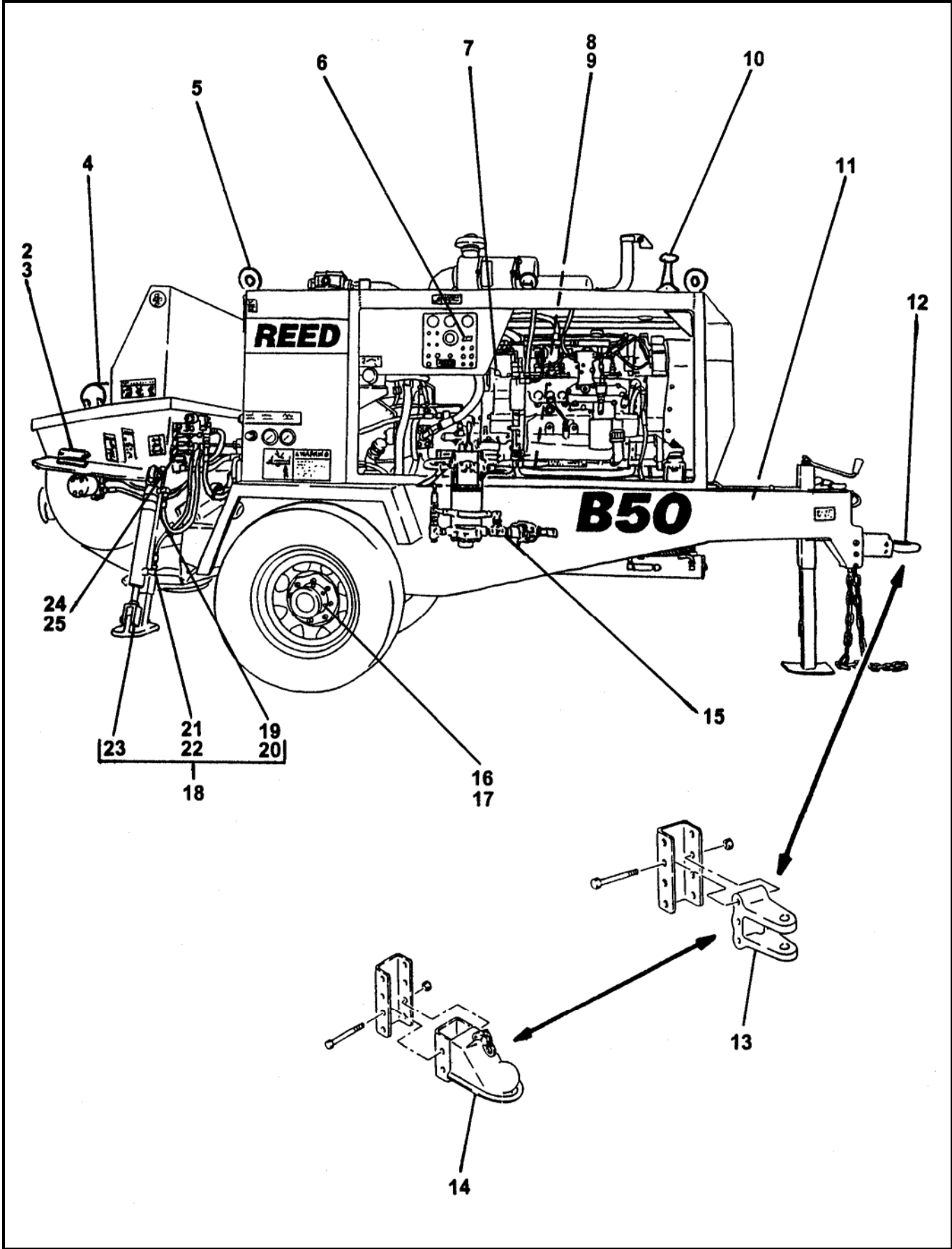

REVISION:





# OPTIONAL INSTALLATION

ITEM NO.	REED'S PARTS NO.	DESCRIPTION	QTY
		1 2 3 4 5	
-1	80-01	Installation, Optional (See Group 10, Figure 01, 02, 03 and 04 for NHA)	Ref
2	80-02	• Assembly, Lube System (See Group 80, Figure 02 for DET)	1
3	78736	• Assembly, Lube Pump (See Group 80, Figure 03 for DET)	1
4	71429	• Assembly, Hopper Vibration (See Group 80, Figure 04 for DET)	1
5	85810	• Assembly, Optional Lifting	1
6	85774	• Assembly, Stroke Counter	1
7	77012	• Assembly, Throttle Solenoid (See Group 80, Figure 05 for DET)	1
8	71460	• Kit, Accumulator Charge (See Group 80, Figure 06 for DET)	1
9	30-11	• Kit, Bladder Repair (See Group 30, Figure 11 for REF)	1
10	85818	• Assembly, Radio Remote Control (See Group 50, Figure 05 for REF)	1
11	79020	• Assembly, Optional Tool Kit (See Group 80, Figure 07 for DET)	1
12	75413	• Assembly, Actuator Brake (See Group 80, Figure 08 for DET)	1
13	71050	• Assembly, Adjustable 1 Inch Clevis	1
14	71099	• Assembly, Adjustable Ball Coupler 2 – 5/16"	1
15	86400	• Installation, Water Pump (See Group 80, Figure 09 for DET)	1
16	80-13	• Assembly, Non-Operator Side Hydraulic Brake (See Group 80, Figure 13 for DET)	1
17	80-14	• Assembly, Operator Side Hydraulic Brake (See Group 80, Figure 14 for DET)	1
18	85677	• Assembly, Hydraulic Outrigger	1
19	85685	• • Assembly, Tube	2
20	85686	• • Assembly, Tube	2
21	85659-010	• • Assembly, Hose (See Schematic Section, Figure 05 for REF)	4
22		• • Elbow, 90	4
23	85640	• • Assembly, Hydraulic Outrigger Cylinder (See Group 80, Figure 15 for DET)	2
24	80-16	• Assembly, 1 Spool Valve (See Group 80, Figure 16 for DET)	1
25	80-18	• Assembly, 2 Spool Valve (See Group 80, Figure 18 for DET)	1
-26	85943	• Assembly, Side Door (See Group 80, Figure 20 for DET)	1
-27	85960	• Assembly, 50 Feet Remote Control Stroke Counter (See Group 80, Figure 21 for DET)	1
-28	85960A	• Assembly, 100 Feet Remote Control Stroke Counter (See Group 80, Figure 22 for DET)	1

DASH (-) ITEM NOT ILLUSTRATED

REVISION:



# LUBE SYSTEM ASSEMBLY

B60  
PARTS  
GROUP 80  
FIGURE 02  
PAGE 01

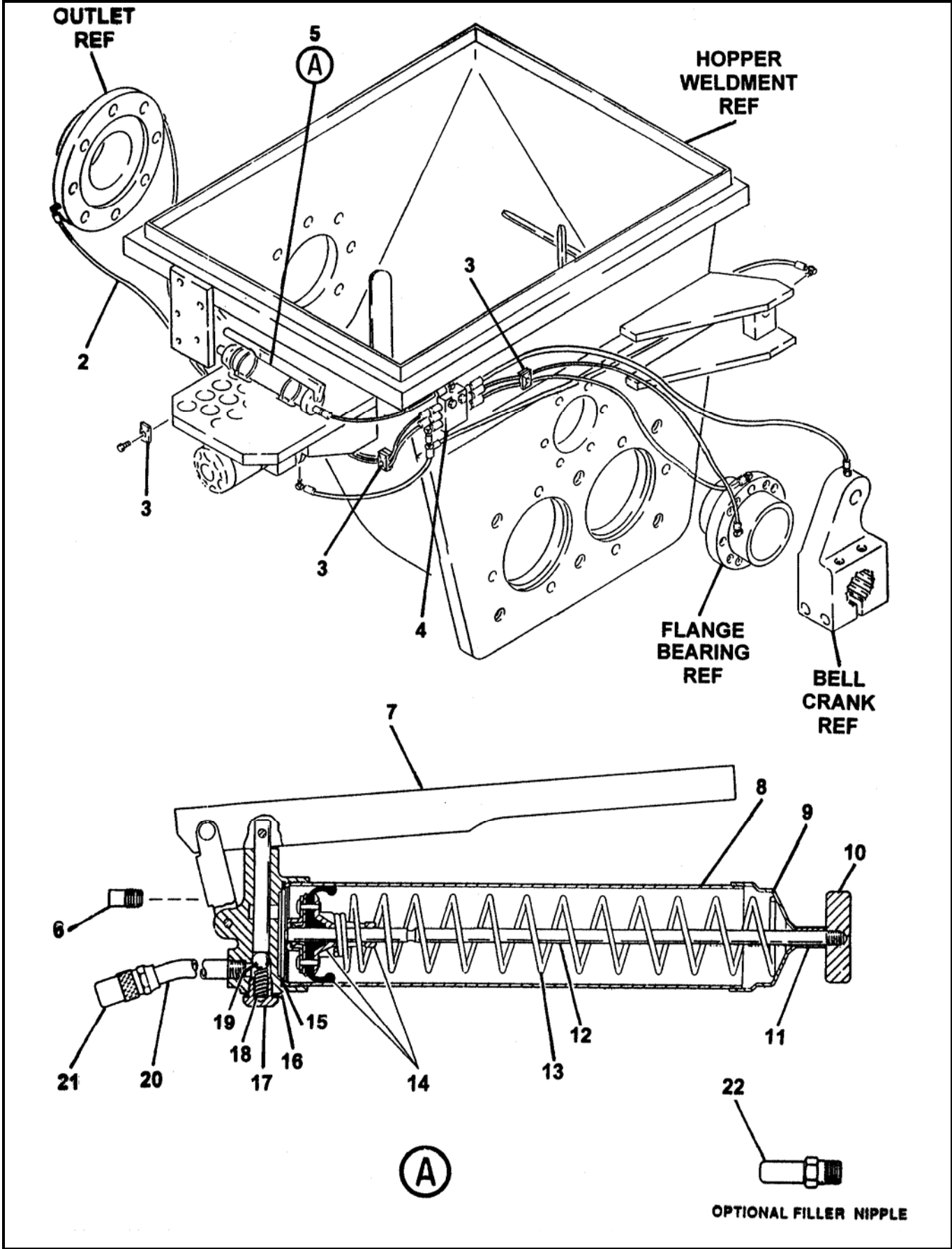



# LUBE SYSTEM ASSEMBLY

B60  
PARTS  
GROUP 80  
FIGURE 02  
PAGE 02

ITEM NO.	REED'S PARTS NO.	DESCRIPTION	QTY
		1 2 3 4 5	
-1	80-02	Assembly, Lube System (See Group 80, Figure 01 for NHA)	Ref
2		• Assembly, Lube Hose	A/R
3	75436	• Clamp, Pipe	3
4	72355	• Block, 6 Station Lube System	1
5	78532	• Gun, Grease	1
6		• • Plug	1
7		• • Handle, Pumping	1
8		• • Tube, Container	1
9		• • Cap, Tube	1
10		• • Handle, Follower	1
11		• • Spacer	1
12		• • Rod, Follower	1
13		• • Spring	1
14		• • Sub-Assembly, Follower	1
15		• • Packing, Container	1
16		• • Gasket	1
17		• • Housing, Spring	1
18		• • Spring	1
19		• • Ball, Check	1
20		• • Extension, Nozzle	1
21		• • Coupler, Hydraulic	1
22		• • Nipple, Filler (Optional Item)	1

DASH (-) ITEM NOT ILLUSTRATED



# LUBE PUMP ASSEMBLY

B60  
PARTS  
GROUP 80  
FIGURE 03  
PAGE 01

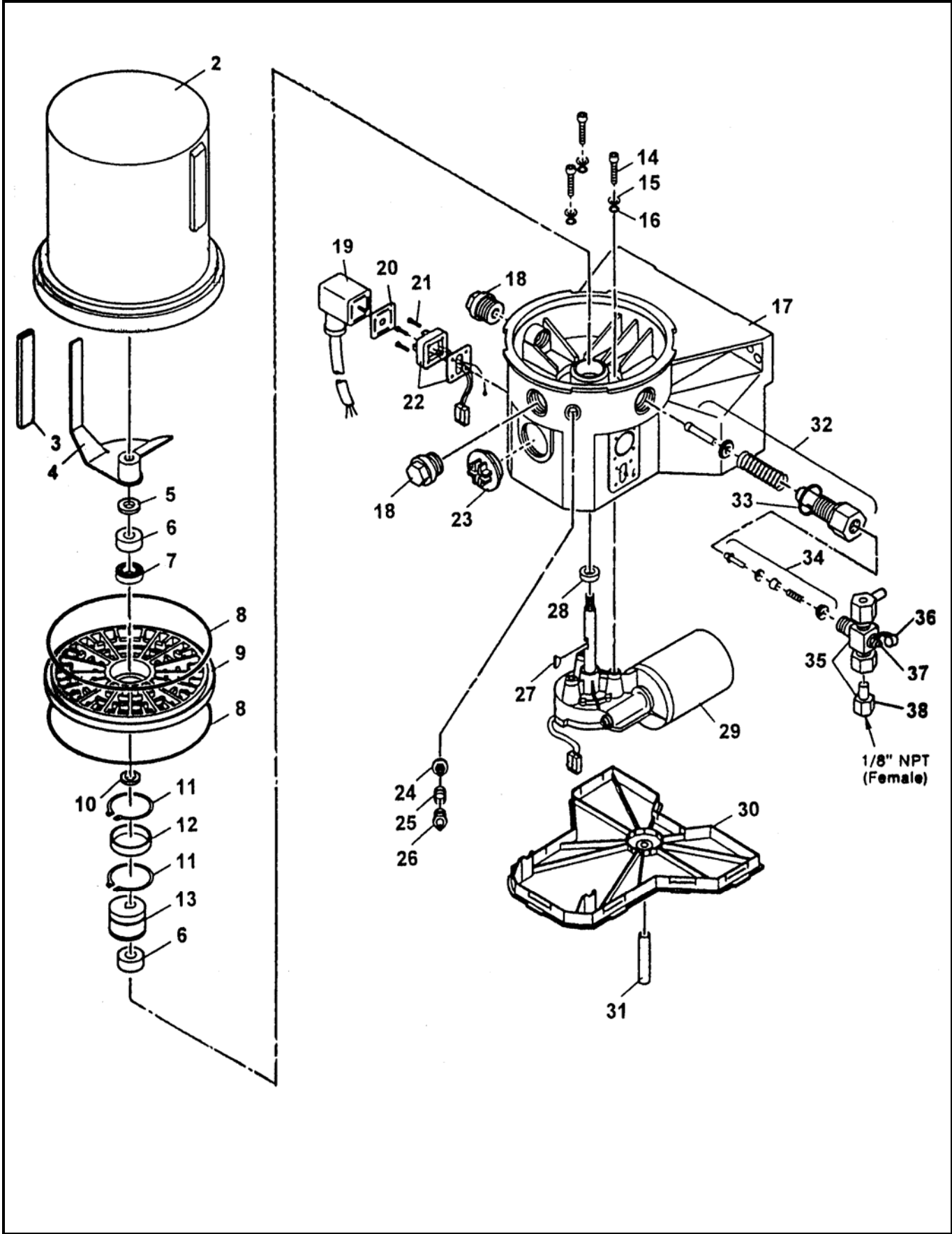

REVISION:



# LUBE PUMP ASSEMBLY

B60  
PARTS  
GROUP 80  
FIGURE 03  
PAGE 02

ITEM NO.	REED'S PARTS NO.	DESCRIPTION					QTY
		1	2	3	4	5	
-1	78736	Assembly, Lube Pump (See Group 80, Figure 01 for NHA)					Ref
2		• Reservoir					1
3		• House					1
4		• Paddle, Stirring					1
5		• Washer					1
6		• Ring, Bearing					2
7		• Bearing					1
8		• O-Ring					2
9		• Plate, Intermediate					1
10		• Shim					1
11		• Ring, Snap					2
12		• Ring, Inner					1
13		• Cam, Eccentric					1
14		• Screw					3
15		• Washer					3
16		• O-Ring					3
17		• Housing, Pump					1
18		• Plug, Closure					2
19		• Socket with Cord					1
20		• Packing, Flat					1
21		• Screw					4
22		• Plug					1
23		• Plug, Sealing					1
24		• Insert, Filter					1
25		• Spring					1
26		• Fitting, Grease					1
27		• Key, Woodruff					1
28		• Seal, Radial					1
29		• Motor, 12 VDC					1
30		• Cover, Housing					1
31		• Hose					1
32		• Element, Pump					1
33		• Gasket					1
34		• Valve, Check					1
35		• Assembly, Pressure Reliefs					1
36		• Cap, Grease					1
37		• Fitting, Grease					1
38		• Assembly, Adapter for Relief					1

DASH (-) ITEM NOT ILLUSTRATED

REVISION:



# HOPPER VIBRATOR ASSEMBLY

B60  
PARTS  
GROUP 80  
FIGURE 04  
PAGE 01

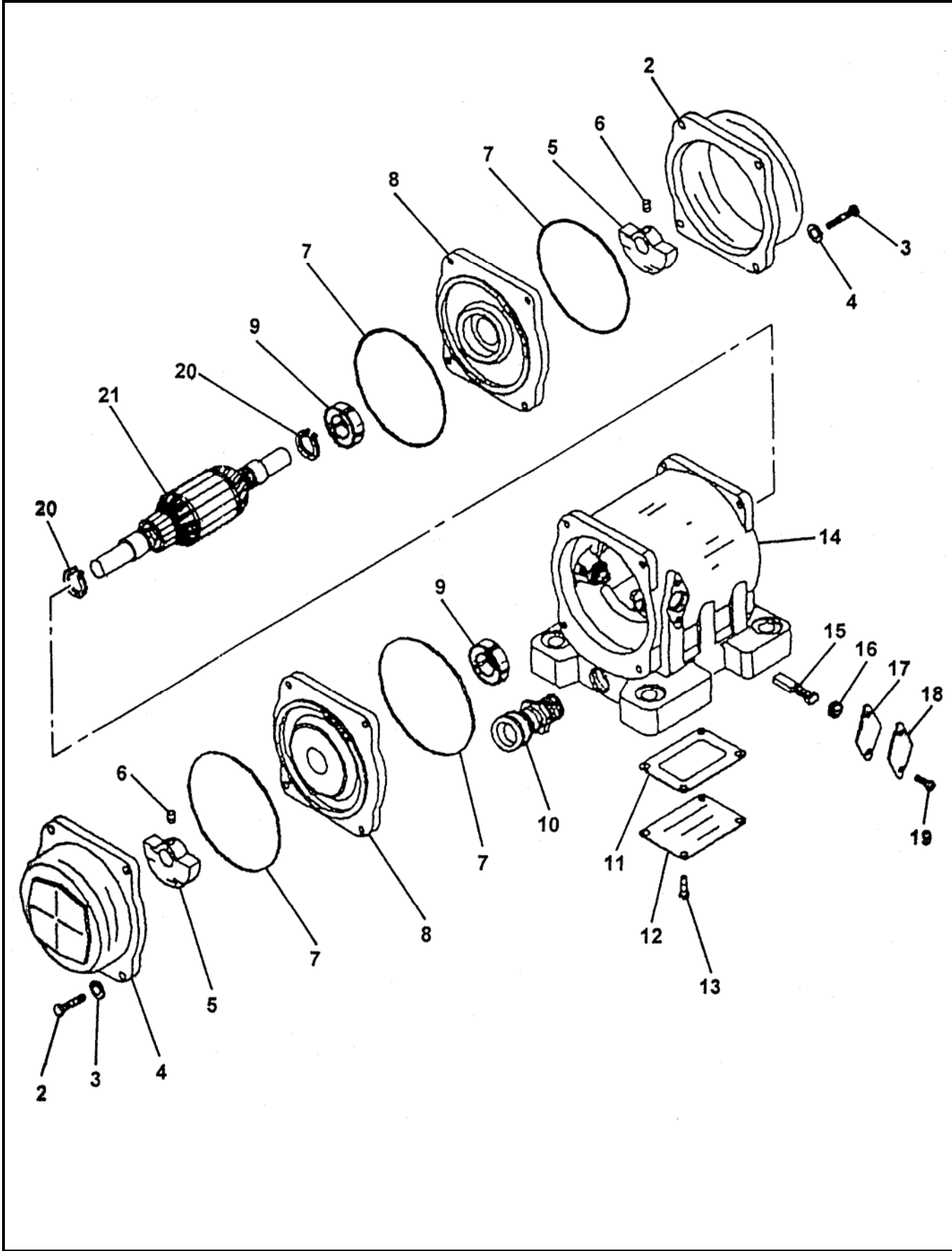

REVISION:



# HOPPER VIBRATOR ASSEMBLY

B60  
**PARTS**  
GROUP 80  
FIGURE 04  
PAGE 02

ITEM NO.	REED'S PARTS NO.	DESCRIPTION	QTY
		1 2 3 4 5	
-1	71429	Assembly, Hopper Vibrator (See Group 80, Figure 01 for NHA)	Ref
2		• Cap, End	2
3		• Bolt (attaching parts)	8
4		• Washer, Lock (attaching parts)	8
5		• Weight	2
6		• Screw, Set (attaching parts)	2
7		• O-Ring	4
8		• Bell, End	2
9		• Bearing	2
10		• Holder, Cord	1
11		• Gasket	1
12		• Cover, Box	1
13		• Screw (attaching parts)	4
14		• Sub-Assembly, Housing	1
15		• Brush	1
16		• Cap, Brush	2
17		• Gasket	2
18		• Cover, Brush	2
19		• Screw (attaching parts)	4
20		• Ring, Snap	2
21		• Assembly, Armature	1

DASH (-) ITEM NOT ILLUSTRATED

REVISION:



# THROTTLE SOLENOID ASSEMBLY

B60  
PARTS  
GROUP 80  
FIGURE 05  
PAGE 01

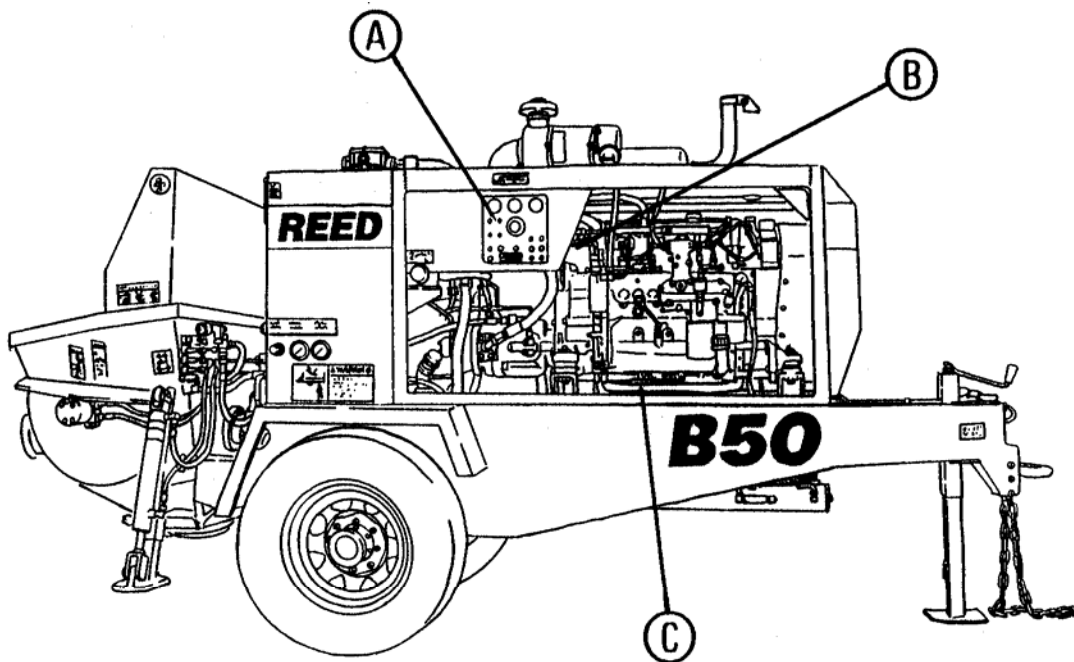

CONTROL BOX REF  
(P/N:85358)

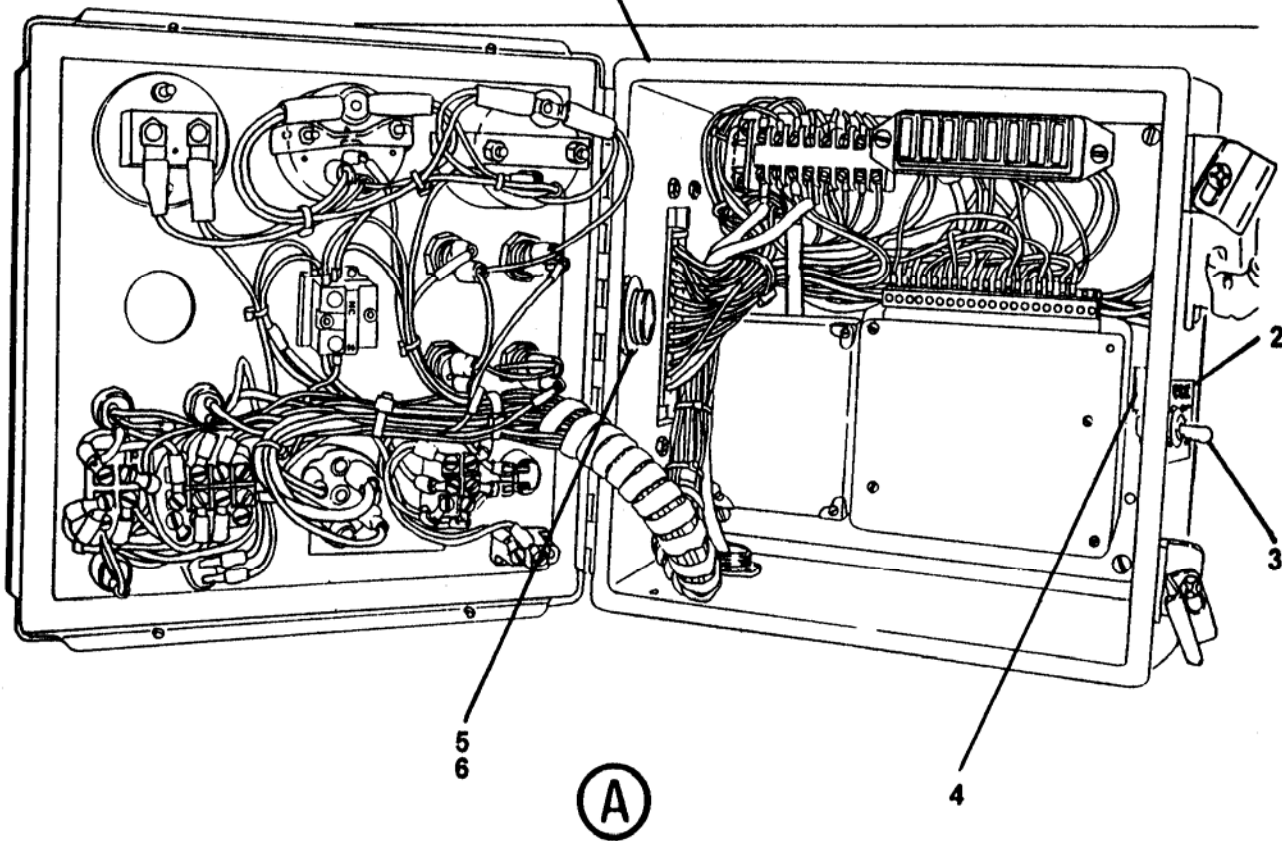





# THROTTLE SOLENOID ASSEMBLY

B60  
**PARTS**  
GROUP 80  
FIGURE 05  
PAGE 02

ITEM NO.	REED'S PARTS NO.	DESCRIPTION	QTY
		1 2 3 4 5	
-1	86134	Assembly, Throttle Solenoid (See Group 80, Figure 01 for NHA)	Ref
2	86131	• Case, Charge Kit	1
3	72965	• Switch, ON/OFF/ON Toggle	1
4	71955	• Relay, 12V	1
5	10523	• Relief, Strain	1
6	10528	• Nut, Bonding Type Lock	1
7	77012	• Solenoid, Throttle	1
8		• • Solenoid	1
9	71955	• • Relay, 12V	1
10	72294	• • Bolt, Throttle Control	1
11	78202	• • Coupler	1
12	85615	• Cable, 7 Feet 14AWG-2C	A/R
13	85617	• Cable, 6 Feet 14AWG-4C	A/R
14	801359	• Holder, Fuse with Cover	1
15	801360	• Fuse, 50AMP	1
16		• Bolt, Hex	1
17		• Washer, flat	2
18		• Nut, Lock	1

DASH (-) ITEM NOT ILLUSTRATED



# THROTTLE SOLENOID ASSEMBLY

B60  
PARTS  
GROUP 80  
FIGURE 05  
PAGE 03

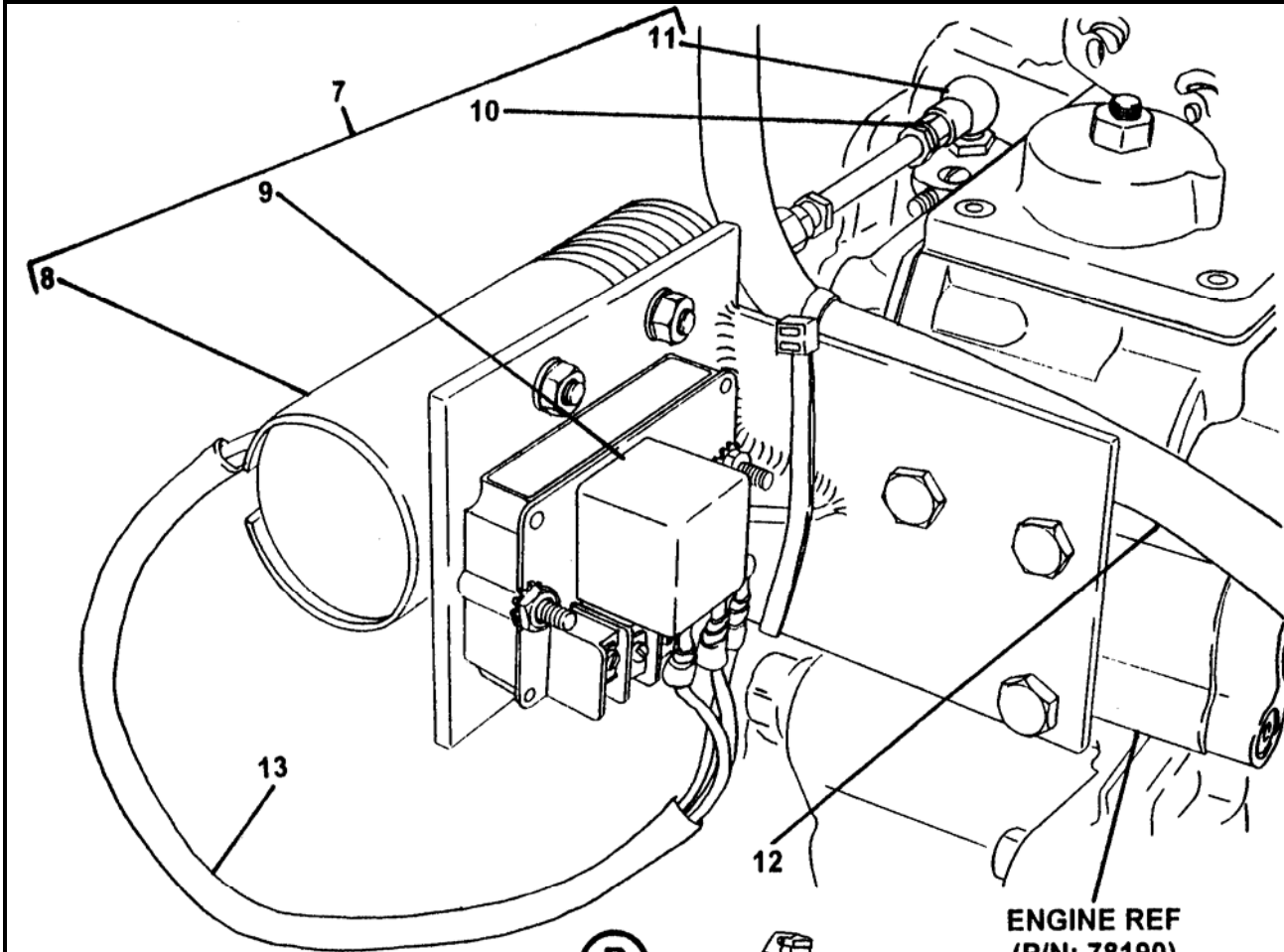

(B)

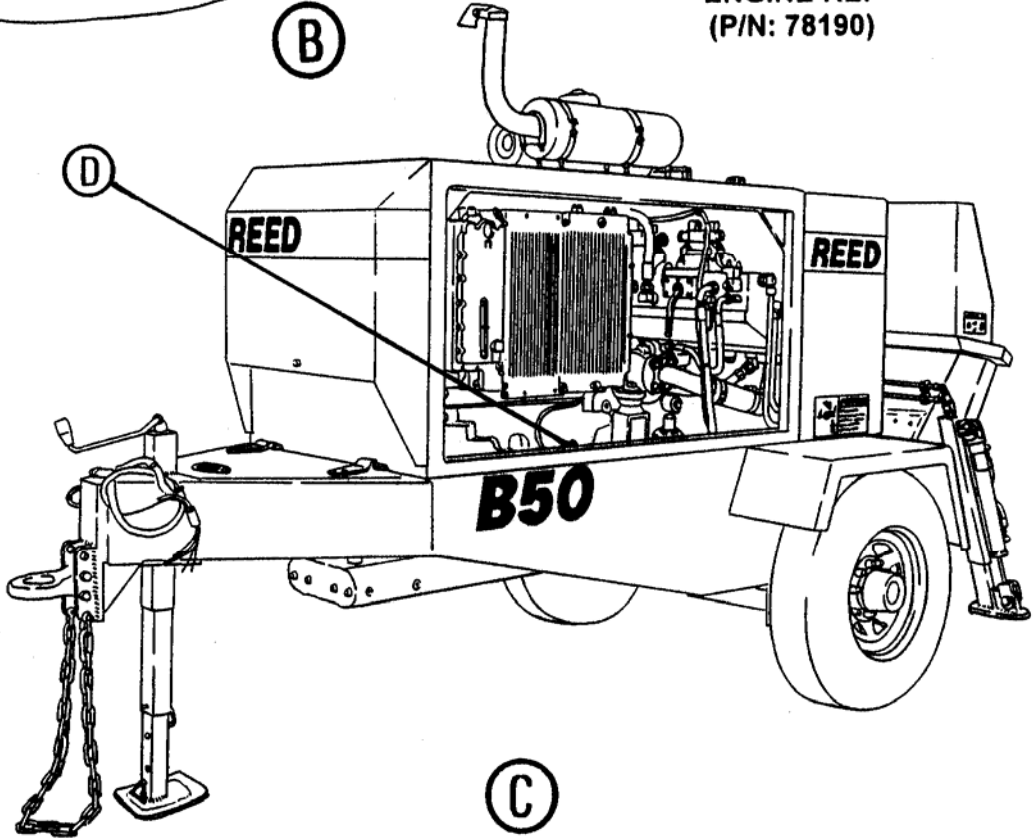

(C)

REVISION:



# THROTTLE SOLENOID ASSEMBLY

B60  
**PARTS**  
 GROUP 80  
 FIGURE 05  
 PAGE 04

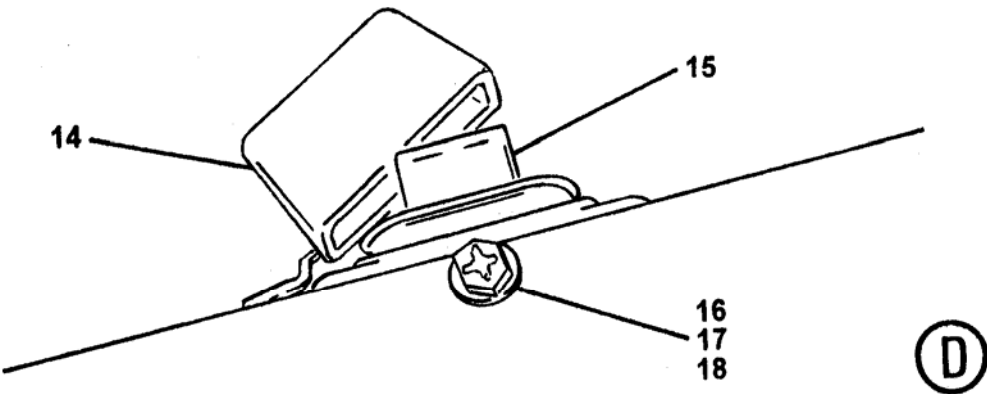

ITEM NO.	REED'S PARTS NO.	DESCRIPTION					QTY
		1	2	3	4	5	
-1	86134	Assembly, Throttle Solenoid (See Group 80, Figure 01 for NHA)					Ref
2	86131	• Case, Charge Kit					1
3	72965	• Switch, ON/OFF/ON Toggle					1
4	71955	• Relay, 12V					1
5	10523	• Relief, Strain					1
6	10528	• Nut, Bonding Type Lock					1
7	77012	• Solenoid, Throttle					1
8		• • Solenoid					1
9	71955	• • Relay, 12V					1
10	72294	• • Bolt, Throttle Control					1
11	78202	• • Coupler					1
12	85615	• Cable, 7 Feet 14AWG-2C					A/R
13	85617	• Cable, 6 Feet 14AWG-4C					A/R
14	801359	• Holder, Fuse with Cover					1
15	801360	• Fuse, 50AMP					1
16		• Bolt, Hex					1
17		• Washer, flat					2
18		• Nut, Lock					1

DASH (-) ITEM NOT ILLUSTRATED

REVISION:



# ACCUMULATOR CHARGE KIT

B60  
PARTS  
GROUP 80  
FIGURE 06  
PAGE 01

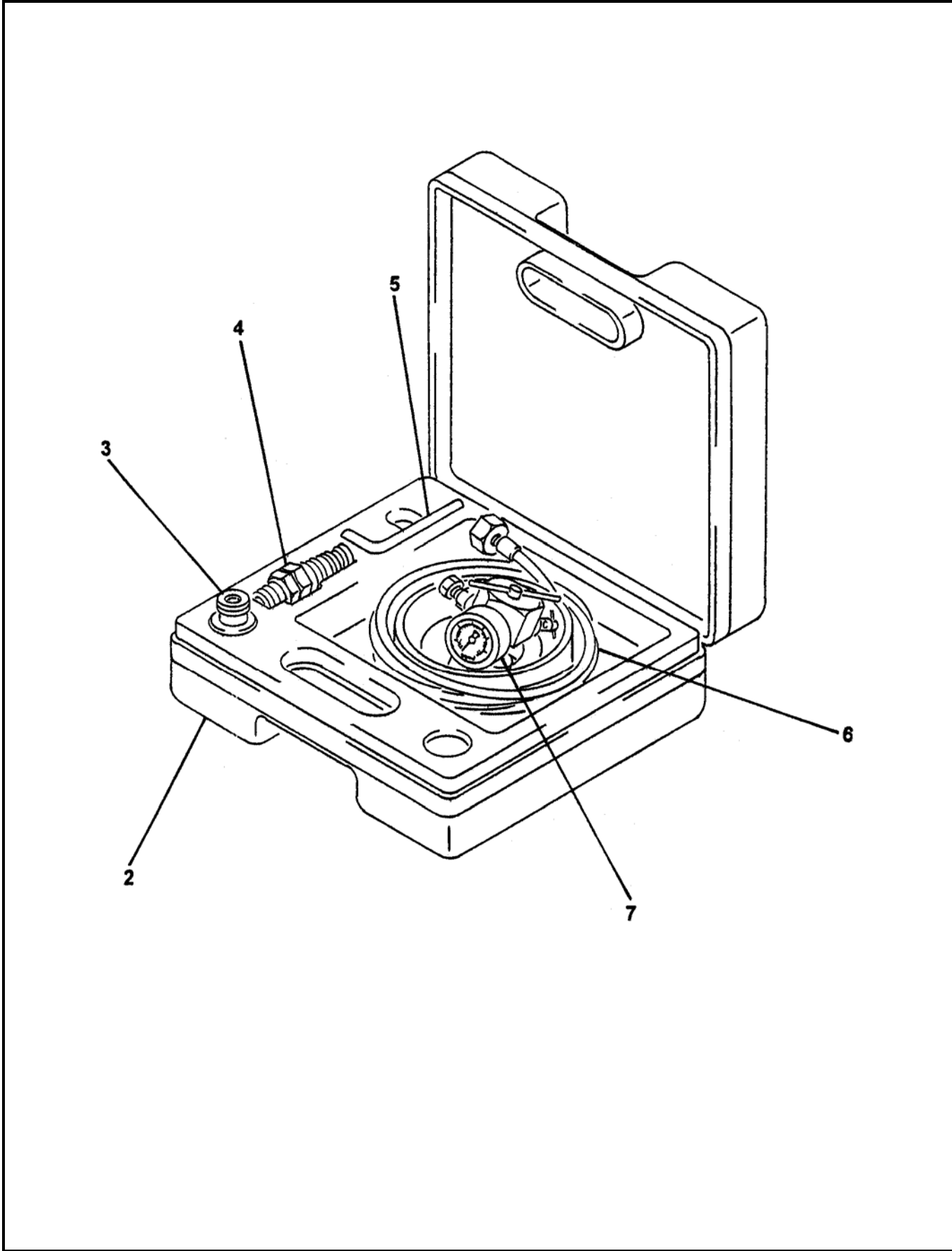

REVISION:



# ACCUMULATOR CHARGE KIT

B60  
**PARTS**  
GROUP 80  
FIGURE 06  
PAGE 02

ITEM NO.	REED'S PARTS NO.	DESCRIPTION	QTY
		1 2 3 4 5	
-1	71460	Kit, Accumulator Charge (See Group 80, Figure 01 for NHA)	Ref
2		• Case, Charge Kit	1
3		• Adapter, FPK / SB	1
4		• Adapter, G4	1
5		• Wrench, Allen	1
6		• Hose, Charging	1
7		• Unit, FPK Charging and Gagging	1

DASH (-) ITEM NOT ILLUSTRATED



# OPTIONAL TOOL KIT ASSEMBLY

B60  
PARTS  
GROUP 80  
FIGURE 07  
PAGE 01

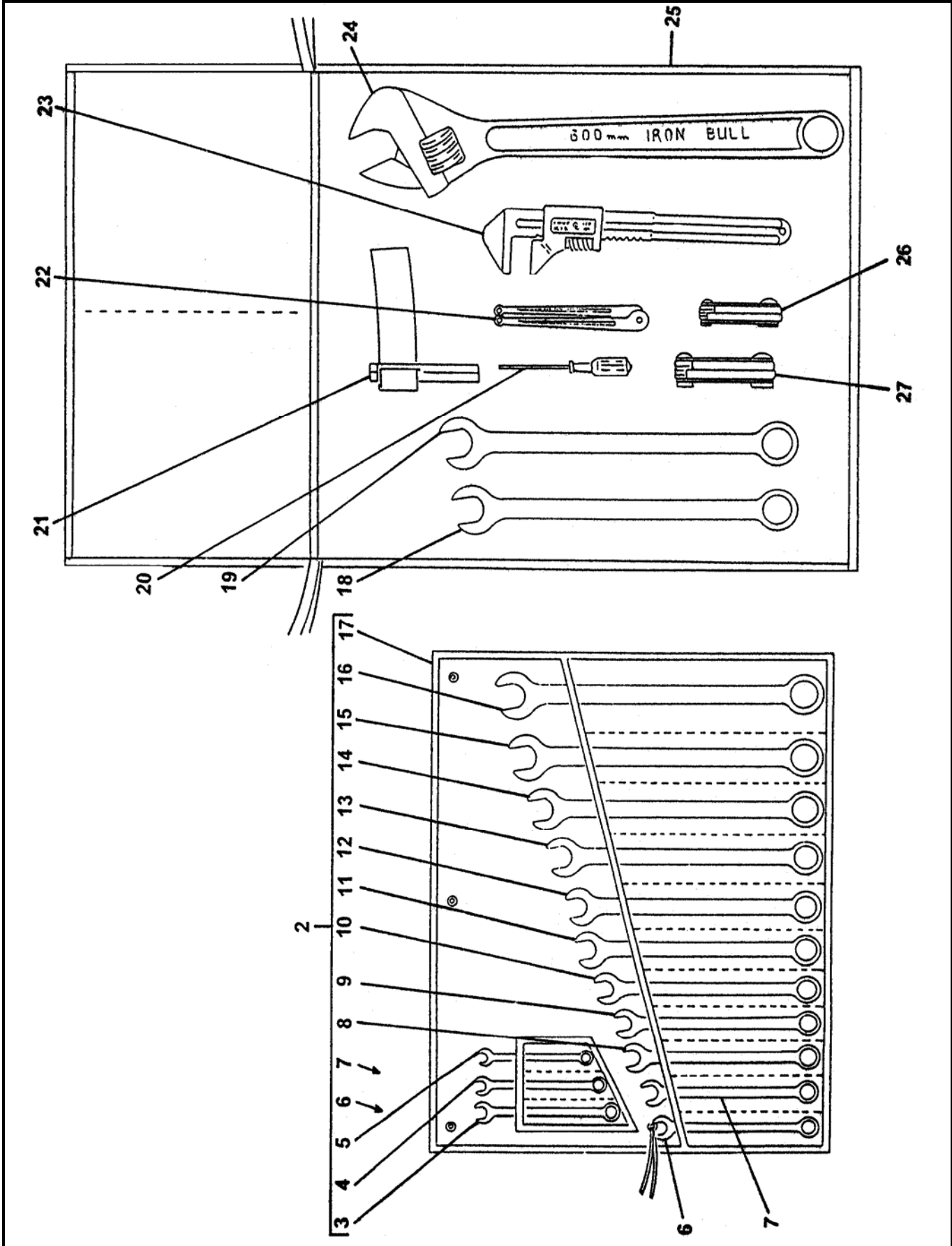

REVISION:



# OPTIONAL TOOL KIT ASSEMBLY

B60  
PARTS  
GROUP 80  
FIGURE 07  
PAGE 02

ITEM NO.	REED'S PARTS NO.	DESCRIPTION	QTY
		1 2 3 4 5	
-1	79020	Assembly, Optional Tool Kit (See Group 80, Figure 01 for NHA)	Ref
2	79037	• Kit, Wrench	1
3		• • Wrench, 1/2 Inch	1
4		• • Wrench, 7/16 Inch	1
5		• • Wrench, 3/8 Inch	1
6		• • Wrench, 9/16 Inch	1
7		• • Wrench, 5/8 Inch	1
8		• • Wrench, 11/16 Inch	1
9		• • Wrench, 3/4 Inch	1
10		• • Wrench, 13/16 Inch	1
11		• • Wrench, 7/8 Inch	1
12		• • Wrench, 15/16 Inch	1
13		• • Wrench, 1 Inch	1
14		• • Wrench, 1-1/16 Inch	1
15		• • Wrench, 1-1/8 Inch	1
16		• • Wrench, 1-1/4 Inch	1
17		• • Wrap, Plastic	1
18	79036	• Wrench, 1-3/8 Inch	1
19	79028	• Wrench, 1-1/2 Inch	1
20	79038	• Screwdriver	1
21	79814	• Wrench, Strap (for Filter)	1
22	79325	• Wrench, Spanner	1
23	79031	• Wrench, Monkey	1
24	79032	• Wrench, Adjustable 24 Inch	1
25	77502	• Bag, Tool	1
26	79030	• Set, Metric Allen Key (2-8 mm)	1
27	79029	• Set, Standard Allen Key (3/16-3/8 Inch)	1

DASH (-) ITEM NOT ILLUSTRATED



# ACTUATOR BRAKES ASSEMBLY

B60  
PARTS  
GROUP 80  
FIGURE 08  
PAGE 01

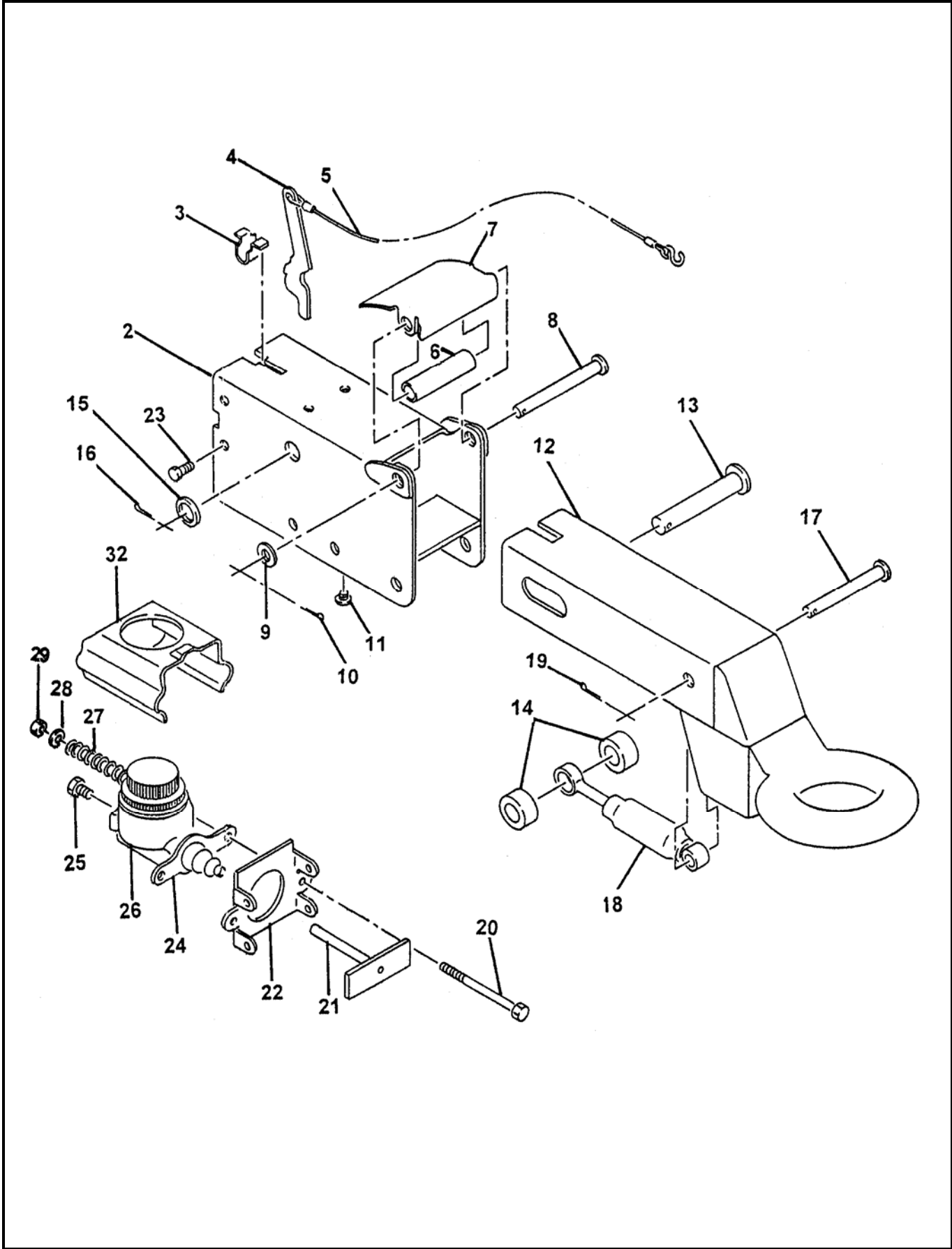

REVISION:





# ACTUATOR BRAKES ASSEMBLY

B60  
**PARTS**  
GROUP 80  
FIGURE 08  
PAGE 02

ITEM NO.	REED'S PARTS NO.	DESCRIPTION					QTY
		1	2	3	4	5	
-1	75413	Assembly, Actuator Brakes (See Group 80, Figure 01 for NHA)					Ref
2		• Case, Outer					1
3		• Spring, Breakaway					1
4		• Lever, Breakaway Pin					1
5		• • S-Hook					1
6		• Roller, Front					1
7		• Cover, Front Roller					1
8		• Pin, Front Roller					1
9		• Washer, Front Roller Pin					1
10		• Pin, Cotter					1
11		• Bearing					2
12		• Lunette Eye, Inner Side					1
13		• Pin, Master					1
14		• Roller, Rear					2
15		• Washer, Master Pin					1
16		• Pin, Cotter					1
17		• Pin, Damper					1
18		• Damper					1
19		• Pin, Cotter					1
20		• Bolt, Hex					2
21		• Rod, Push					1
22		• Plate, Cylinder Mounting					1
23		• Bolt, Self Topping					4
24		• Cylinder, Master					1
25		• Connector, Orifice					1
26		• Cap, Master Cylinder with Gasket					1
27		• Spring					2
28		• Washer					2
29		• Nut, hex					2

DASH (-) ITEM NOT ILLUSTRATED



# WATER PUMP INSTALLATION

B60  
PARTS  
GROUP 80  
FIGURE 09  
PAGE 01

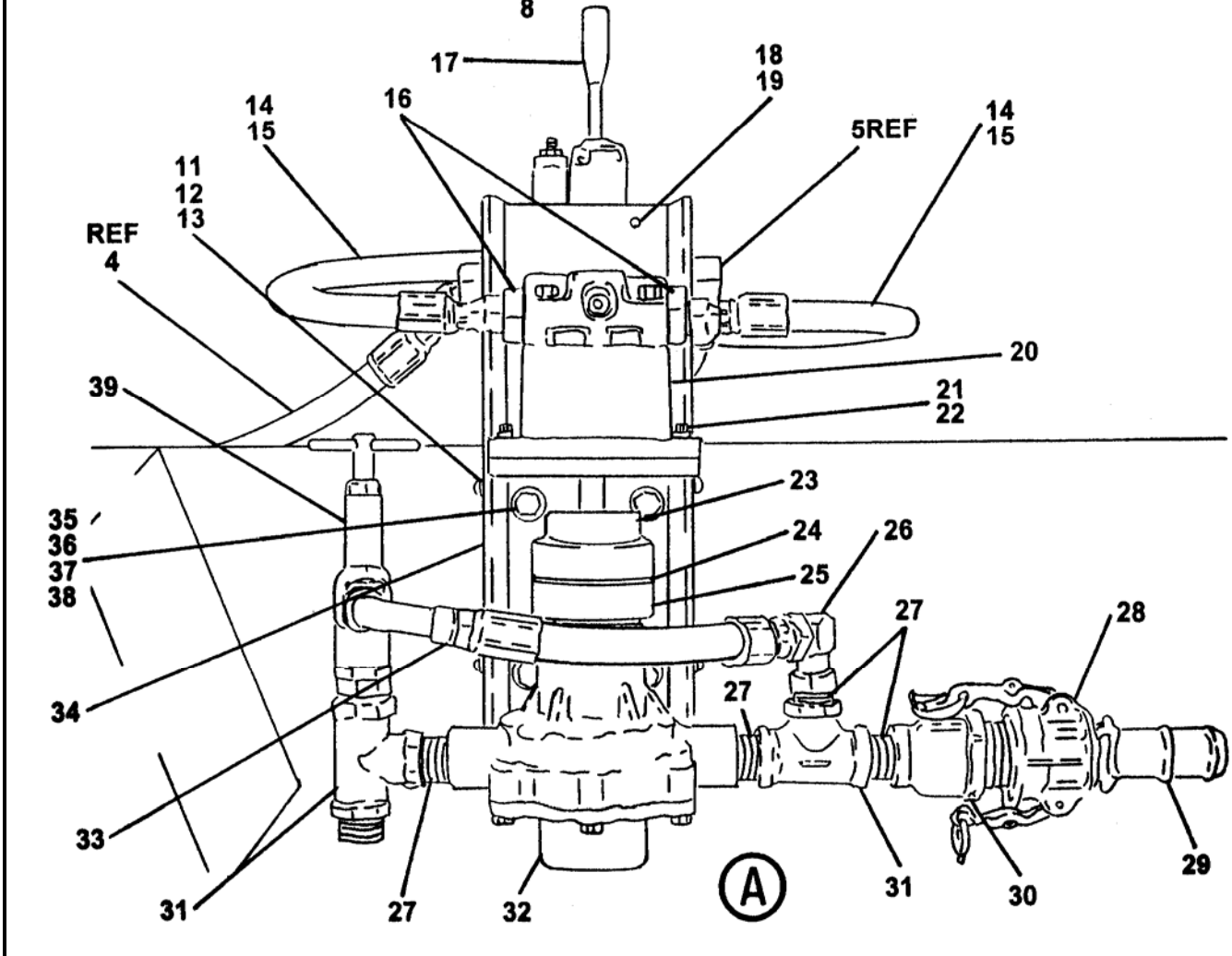
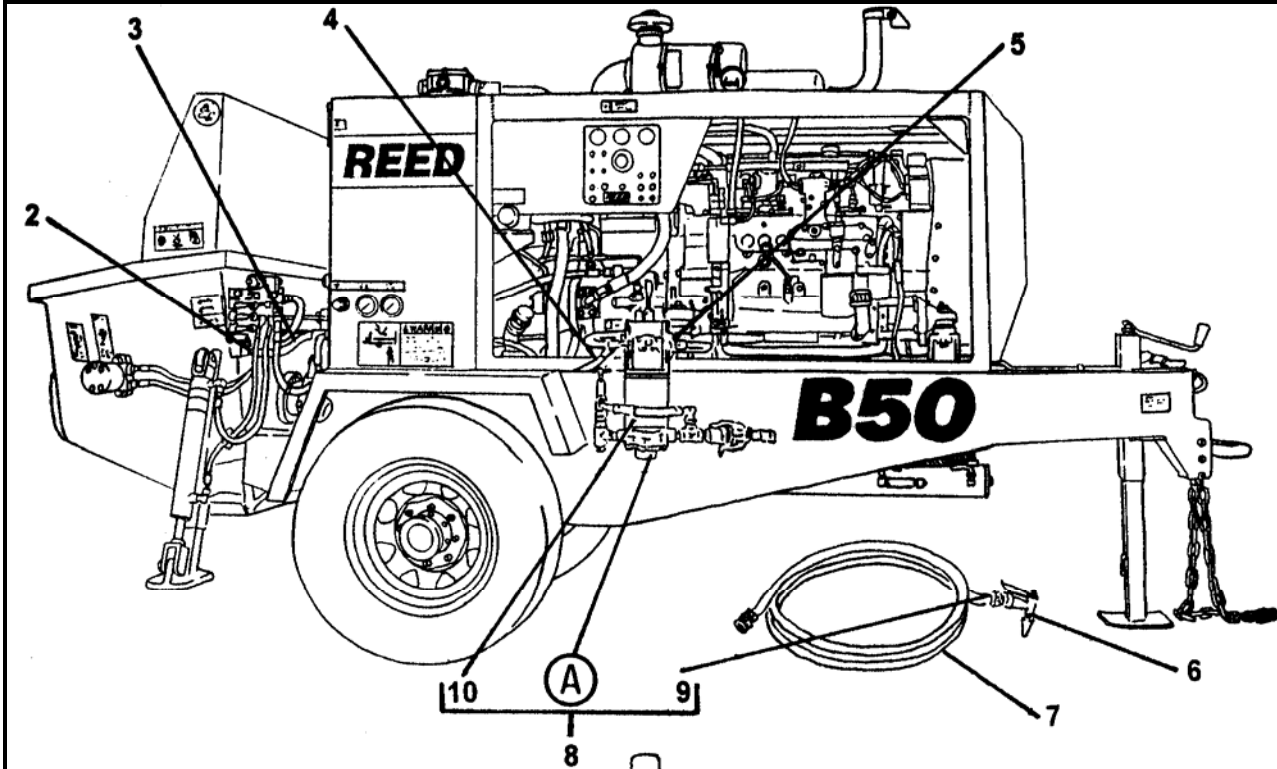

REVISION:



# WATER PUMP INSTALLATION

**B60**  
**PARTS**  
 GROUP 80  
 FIGURE 09  
 PAGE 02

ITEM NO.	REED'S PARTS NO.	DESCRIPTION					QTY
		1	2	3	4	5	
-1	86400	Installation, Water Pump (See Group 80, Figure 01 for NHA)					Ref
2	86384	• Sleeve, Power Beyond					1
3		• Assembly, Hose					1
4		• Assembly, Hose					1
5		• Assembly, Hose					1
6	800098	• Nozzle, Garden Hose					1
7	86267	• Hose, Garden 20 FT					1
8	86200	• Kit, Wash Pump					1
9	800371	• • Fitting, Garden Hose					1
10	86199	• • Cover, Wash Pump					1
11		• • Screw (attaching parts)					4
12		• • Washer, SPL Lock (attaching parts)					4
13		• • Washer, Flat (attaching parts)					4
14		• • Fitting, 90					2
15	85658-002	• • Assembly, Hose					2
16		• • Fitting, STR					2
17	86397	• • Assembly, Water Pump Control Valve (See Group 80, Figure 10 for DET)					1
18		• • Bolt (attaching parts)					2
19		• • Washer, SPL Lock (attaching parts)					2
20	78152	• • Assembly, Water Pump Motor (See Group 80, Figure 11 for DET)					1
21		• • Bolt, Hex (attaching parts)					2
22		• • Washer, SPL Lock (attaching parts)					2
23	78153	• • Coupling, Wash Motor					1
24	78155	• • Spider					1
25	78154	• • Coupling, Wash Pump					1
26		• • Fitting, 90					1
27	40047	• • Nipple, Close, Pipe					5
28	10947	• • Coupling, Female Cam / Groove					1
29	10948	• • Coupling, Male Cam / Groove					1
30	86398	• • Reducer, Bell					1
31	10228	• • Tee					2
32	78157	• • Assembly, Water Pump (See Group 80, Figure 12 for DET)					1
33	85657-022	• • Assembly, Hose					1
34	86196	• • Weldment, Wash Pump Base					1
35		• • Bolt, Hex (attaching parts)					4
36		• • Washer, Flat (attaching parts)					8
37		• • Washer, SPL Lock (attaching parts)					4
38		• • Nut, Lock (attaching parts)					4
39	78128	• • Valve, Relief					1

DASH (-) ITEM NOT ILLUSTRATED

REVISION:



# WATER PUMP CONTROL VALVE ASSEMBLY

B60  
PARTS  
GROUP 80  
FIGURE 10  
PAGE 01

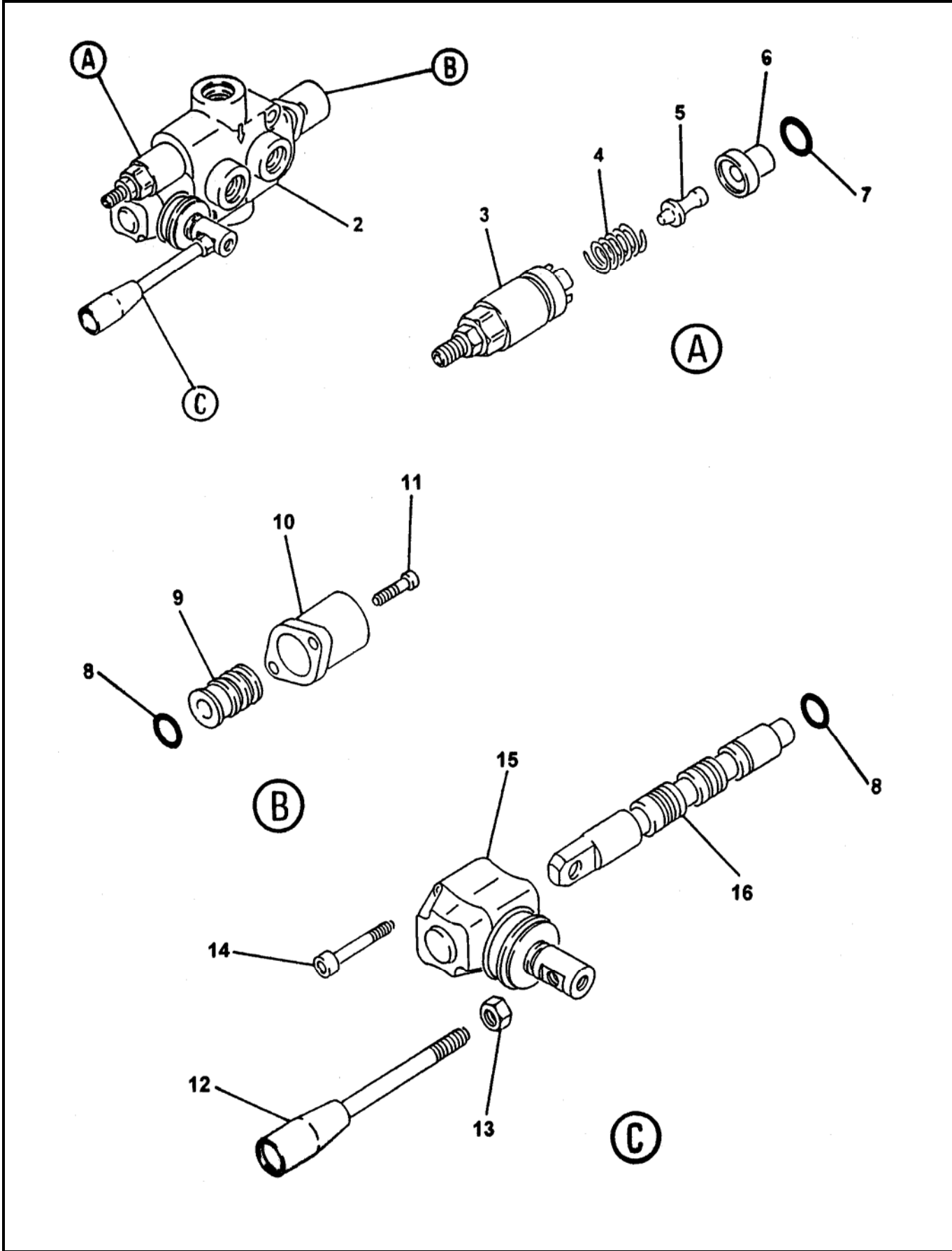

REVISION:



# WATER PUMP CONTROL VALVE ASSEMBLY

B60  
PARTS  
GROUP 80  
FIGURE 10  
PAGE 02

ITEM NO.	REED'S PARTS NO.	DESCRIPTION	QTY
		1 2 3 4 5	
-1	86397	Assembly, Water Pump Control Valve (See Group 80, Figure 09 for NHA)	Ref
2		• Body, Valve	1
3		• Kit, Screw	1
4		• Spring	1
5		• Pin, Screw Kit	1
6		• Ring	1
7		• O-Ring	1
8		• O-Ring	2
9		• Kit, Spool Control	1
10		• Cap, Spool	1
11		• Screw, SOC (attaching Parts)	2
12		• Handle, Remixer Valve	1
13		• Nut (attaching parts)	1
14		• Screw, SOC	2
15		• Lever, L	1
16		• Spool	1

DASH (-) ITEM NOT ILLUSTRATED

REVISION:



# WATER PUMP MOTOR ASSEMBLY

B60  
PARTS  
GROUP 80  
FIGURE 11  
PAGE 01

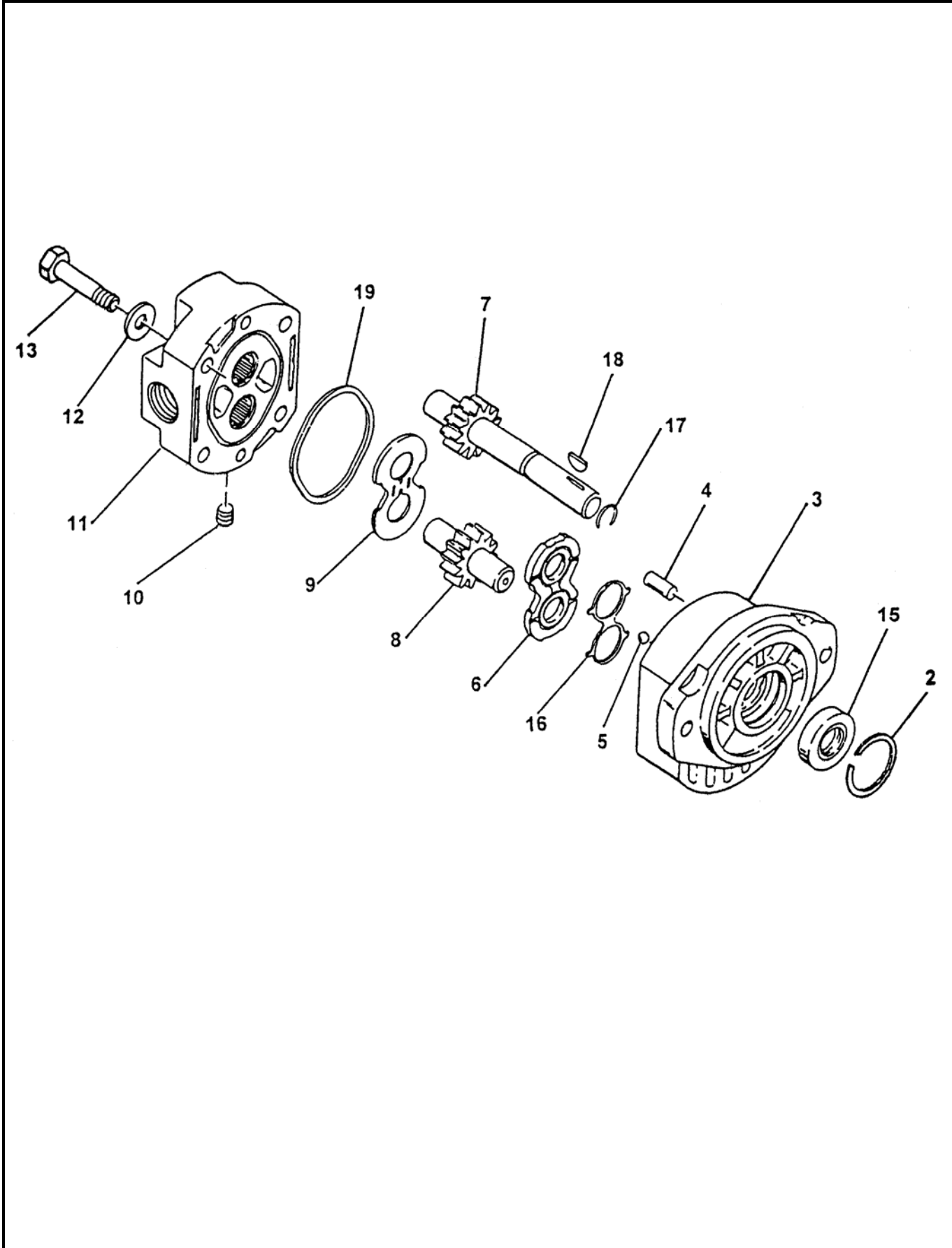

REVISION:



# WATER PUMP MOTOR ASSEMBLY

B60  
**PARTS**  
GROUP 80  
FIGURE 11  
PAGE 02

ITEM NO.	REED'S PARTS NO.	DESCRIPTION					QTY
		1	2	3	4	5	
-1	78152	Assembly, Wash Pump Motor (See Group 80, Figure 09 for NHA)					Ref
2		• Retainer					1
3		• Assembly, Body					1
4		• Pin, Dowel					2
5		• Bearing, Ball					2
6		• Plate, Wear					1
7		• Gear, Driven Wear					1
8		• Gear, Driven					1
9		• Plate, Thrust					1
10		• Plug, Pipe					4
11		• Assembly, Cover					1
12		• Washer (attaching parts)					4
13		• Screw, Hex (attaching parts)					4
14		• Kit, Seal					1
15		• • Brush					1
16		• • Cap, Brush					1
17		• • Gasket					1
18		• • Cover, Brush					1

DASH (-) ITEM NOT ILLUSTRATED



# WATER PUMP ASSEMBLY

B60  
PARTS  
GROUP 80  
FIGURE 12  
PAGE 01

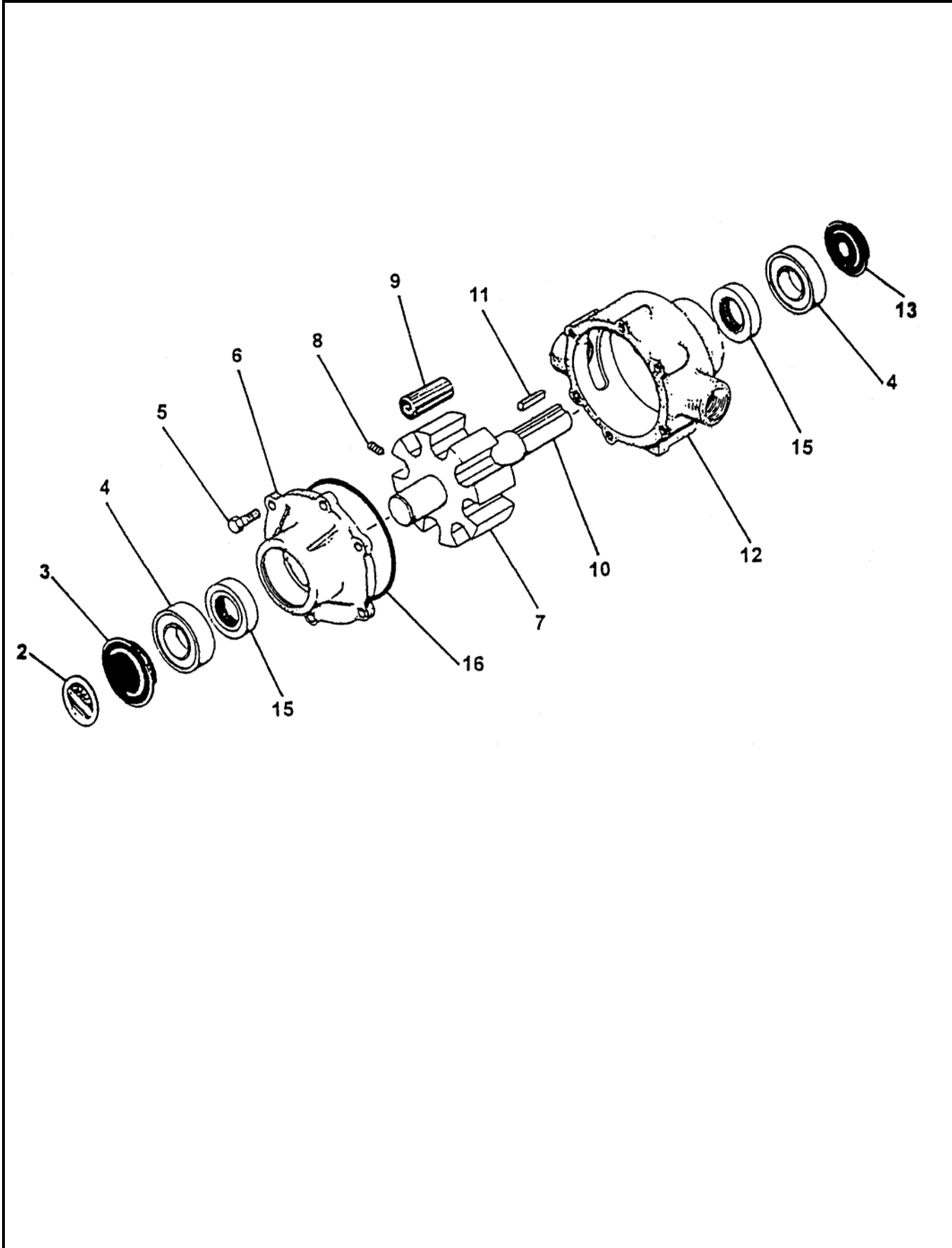

REVISION:





# WATER PUMP ASSEMBLY

B60  
**PARTS**  
GROUP 80  
FIGURE 12  
PAGE 02

ITEM NO.	REED'S PARTS NO.	DESCRIPTION	QTY
		1 2 3 4 5	
-1	78157	Assembly, Wash Water Pump (See Group 80, Figure 09 for NHA)	Ref
2		• Plate, Name	1
3		• Cover, Bearing Rear	1
4		• Bearing, Sealed Bowl	2
5		• Endplate, (Ni-Resist) with Seal	1
6		• Bolt, Hex (attaching parts)	6
7		• Rotor, (Ni-Resist) with Shaft	1
8		• Screw, Set (attaching parts)	1
9		• Roller, Teflon	1
10		• Shaft	1
11		• Key	1
12		• Body, (Ni-Resist) with Seal	1
13		• Cover, Bearing Shaft	1
-14	72329	• Kit, Seal	1
15		• • Seal, Buna	2
16		• • Gasket, End Plate O-Ring	1

DASH (-) ITEM NOT ILLUSTRATED

REVISION:



# NON-OPERATOR SIDE HYDRAULIC BRAKE ASSEMBLY

B60  
PARTS  
GROUP 80  
FIGURE 13  
PAGE 01

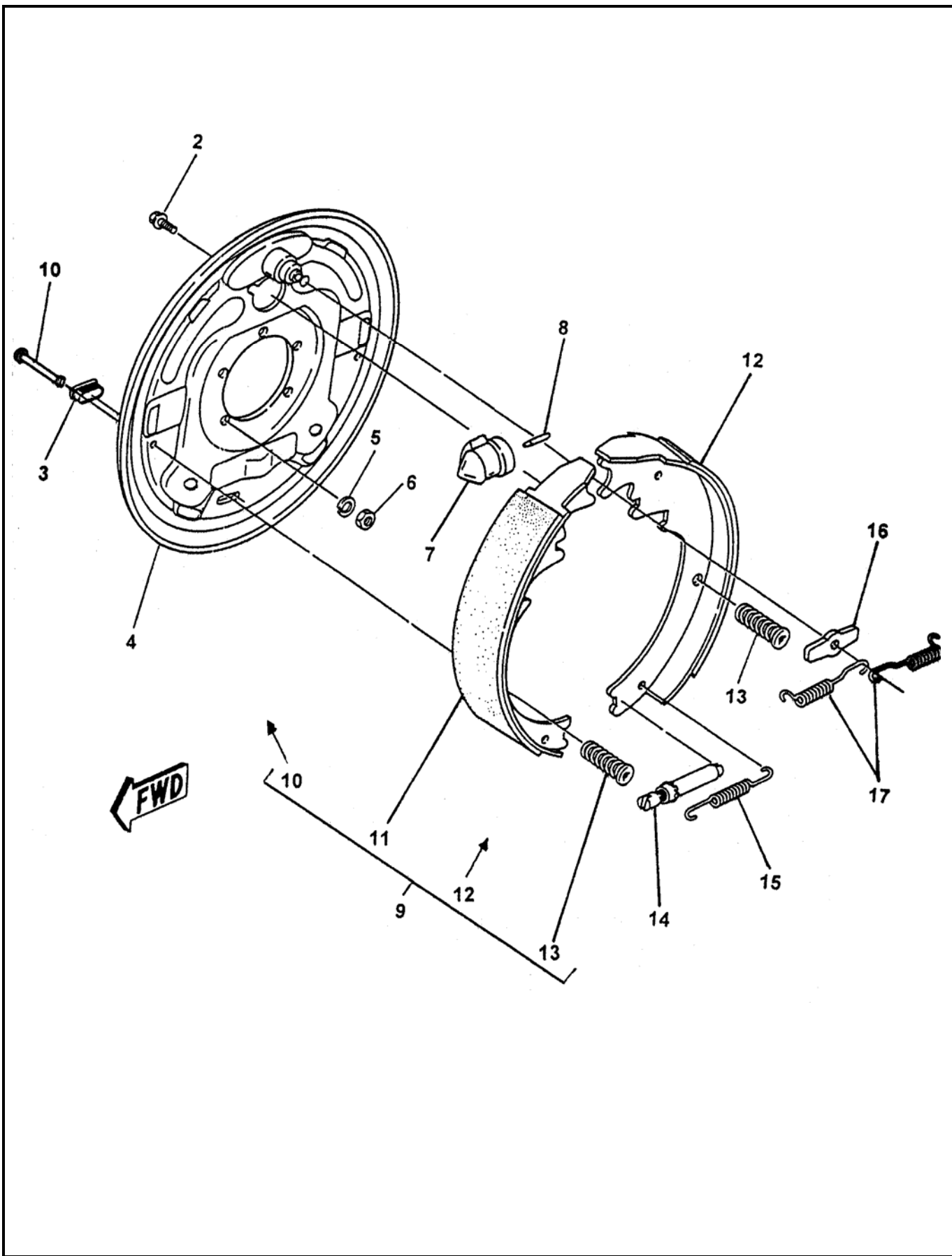

REVISION:



# NON-OPERATOR SIDE HYDRAULIC BRAKE ASSEMBLY

B60  
**PARTS**  
GROUP 80  
FIGURE 13  
PAGE 02

ITEM NO.	REED'S PARTS NO.	DESCRIPTION	QTY
		1 2 3 4 5	
-1	80-12	Assembly, Non-Operator Side Hydraulic Brake (See Group 80, Figure 01 for NHA)	Ref
2		• Screw, with Washer	1
3		• Plug	2
4		• Plate, Backing	1
5		• Washer, Lock (attaching parts)	5
6		• Nut, Brake Mounting (attaching parts)	5
7		• Cylinder, Non-Operator Side Brake	1
8		• Rod, Push	1
9		• Kit, Non-Operator Side Shoe and Lining	1
10		• • Pin, Shoe Hold Down	2
11		• • Primary, Non-Operator Side	1
12		• • Secondary, Non-Operator Side	1
13		• • Pin, Shoe Hold Down	2
14		• Assembly, Adjuster	1
15		• Spring, Adjusting Screw	1
16		• Washer, Anchor Post	1
17		• Spring, Retractor	2

DASH (-) ITEM NOT ILLUSTRATED

REVISION:



# OPERATOR SIDE HYDRAULIC BRAKE ASSEMBLY

B60  
PARTS  
GROUP 80  
FIGURE 14  
PAGE 01

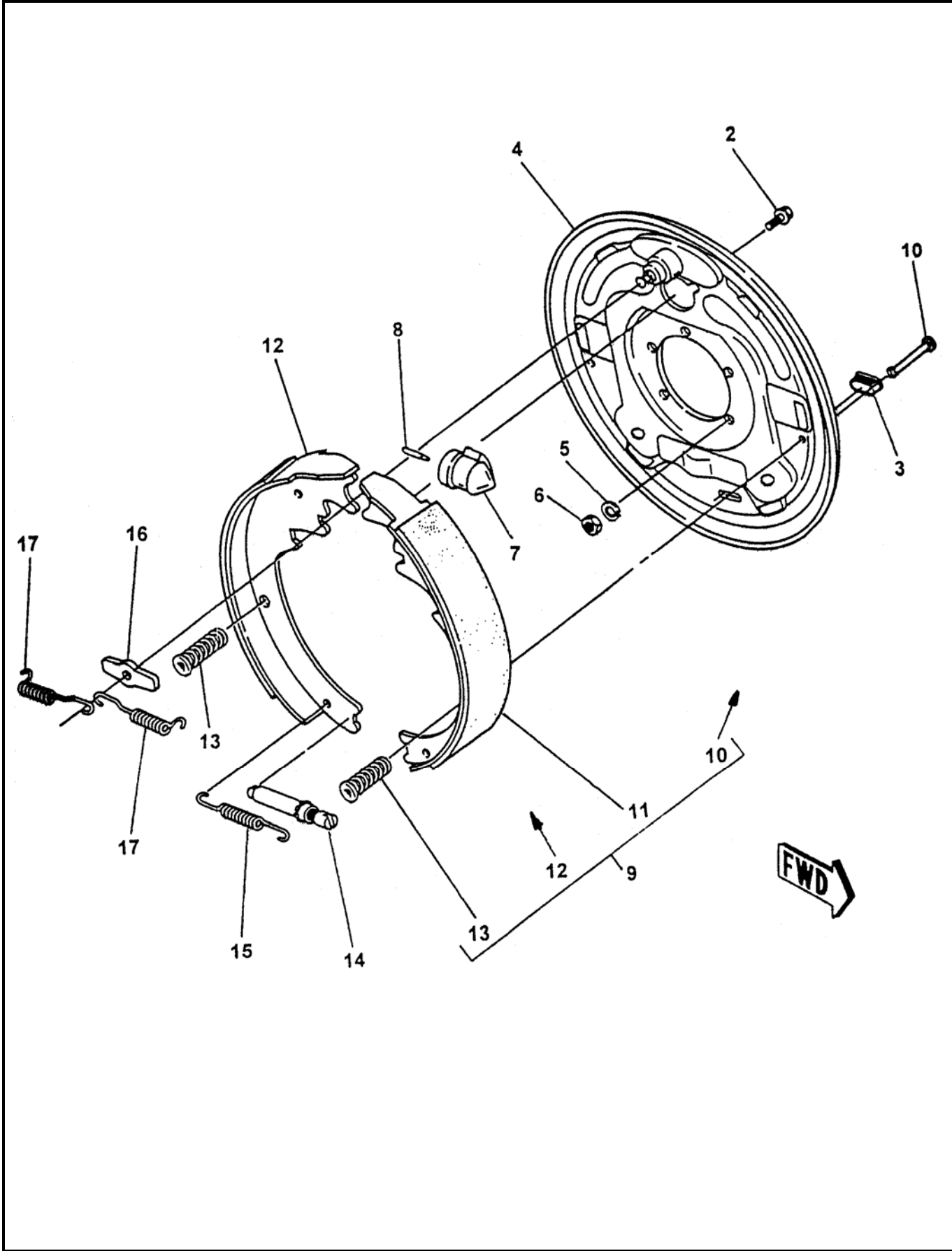

REVISION:



**OPERATOR SIDE  
HYDRAULIC BRAKE ASSEMBLY**

**B60**  
**PARTS**  
GROUP 80  
FIGURE 14  
PAGE 02

ITEM NO.	REED'S PARTS NO.	DESCRIPTION	QTY
		1 2 3 4 5	
-1	80-13	Assembly, Operator Side Hydraulic Brake (See Group 80, Figure 01 for NHA)	Ref
2		• Screw, with Washer	1
3		• Plug	2
4		• Plate, Backing	1
5		• Washer, Lock (attaching parts)	5
6		• Nut, Brake Mounting (attaching parts)	5
7		• Cylinder, Operator Side Brake	1
8		• Rod, Push	1
9		• Kit, Operator Side Shoe and Lining	1
10		• • Pin, Shoe Hold Down	2
11		• • Primary, Operator Side	1
12		• • Secondary, Operator Side	1
13		• • Pin, Shoe Hold Down	2
14		• Assembly, Adjuster	1
15		• Spring, Adjusting Screw	1
16		• Washer, Anchor Post	1
17		• Spring, Retractor	2

DASH (-) ITEM NOT ILLUSTRATED

REVISION:



# HYDRAULIC OUTRIGGER CYLINDER ASSEMBLY

B60  
PARTS  
GROUP 80  
FIGURE 15  
PAGE 01

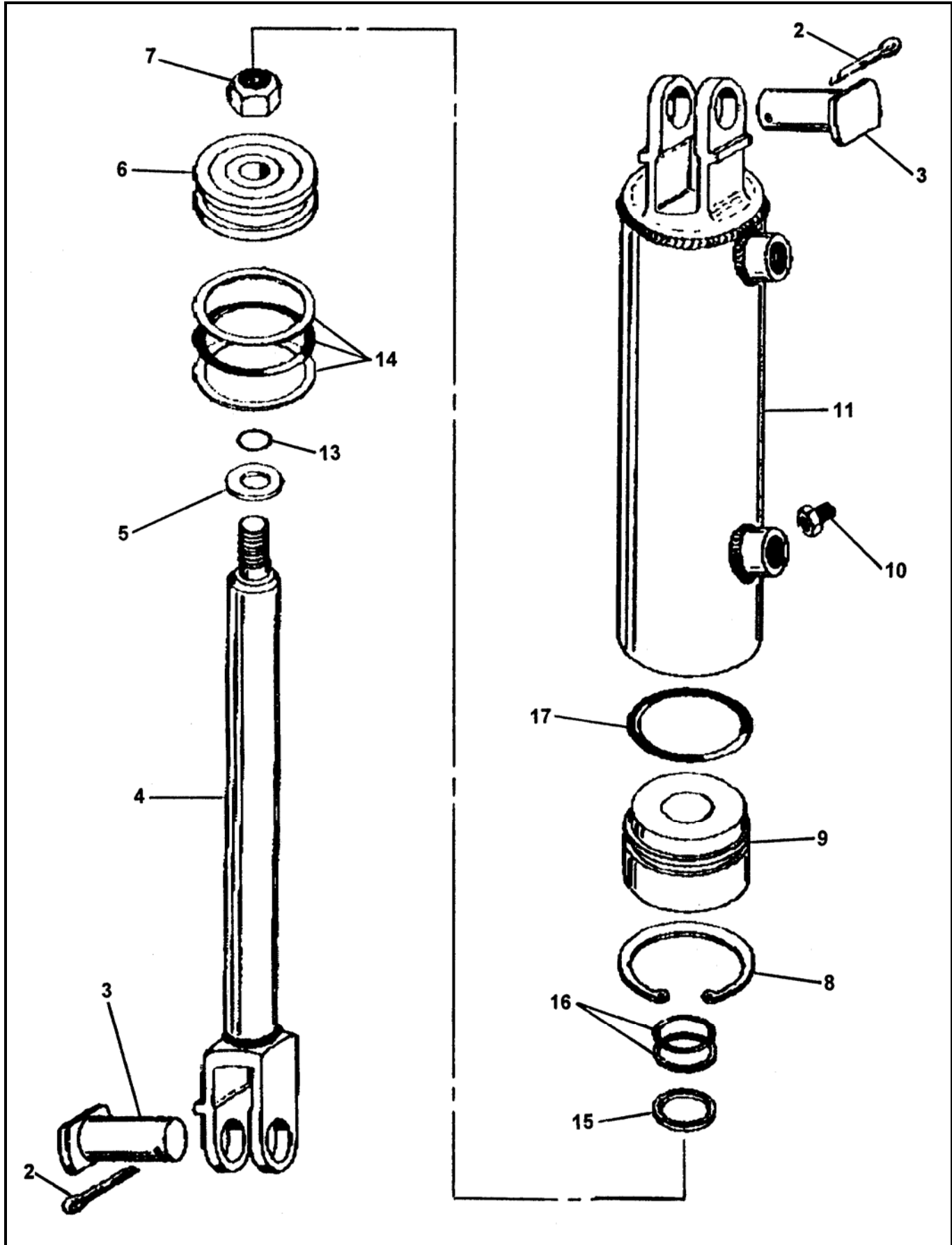

REVISION:



# HYDRAULIC OUTRIGGER CYLINDER ASSEMBLY

B60  
**PARTS**  
GROUP 80  
FIGURE 15  
PAGE 02

ITEM NO.	REED'S PARTS NO.	DESCRIPTION					QTY
		1	2	3	4	5	
-1	85640	Assembly, Hydraulic Outrigger Cylinder (See Group 80, Figure 01 for NHA)					Ref
2		• Pin, Safety					2
3		• Pin, Clevis					2
4		• Assembly, Shaft					1
5		• Washer, Steel					1
6		• Piston					1
7		• Nut, Piston Lock					1
8		• Ring, Head Lock					1
9		• Head					1
10		• Screw, Head Set					1
11		• Assembly, Tube					1
-12	74497	• Kit, Seal					1
13		• • O-Ring, Small					1
14		• • Sub-Assembly, Piston O-Ring					1
15		• • Wiper, Rod					1
16		• • Packing, Shaft (Pair)					1
17		• • O-Ring, Head					1

DASH (-) ITEM NOT ILLUSTRATED



# 1 SPOOL CONTROL VALVE ASSEMBLY

B60  
PARTS  
GROUP 80  
FIGURE 16  
PAGE 01

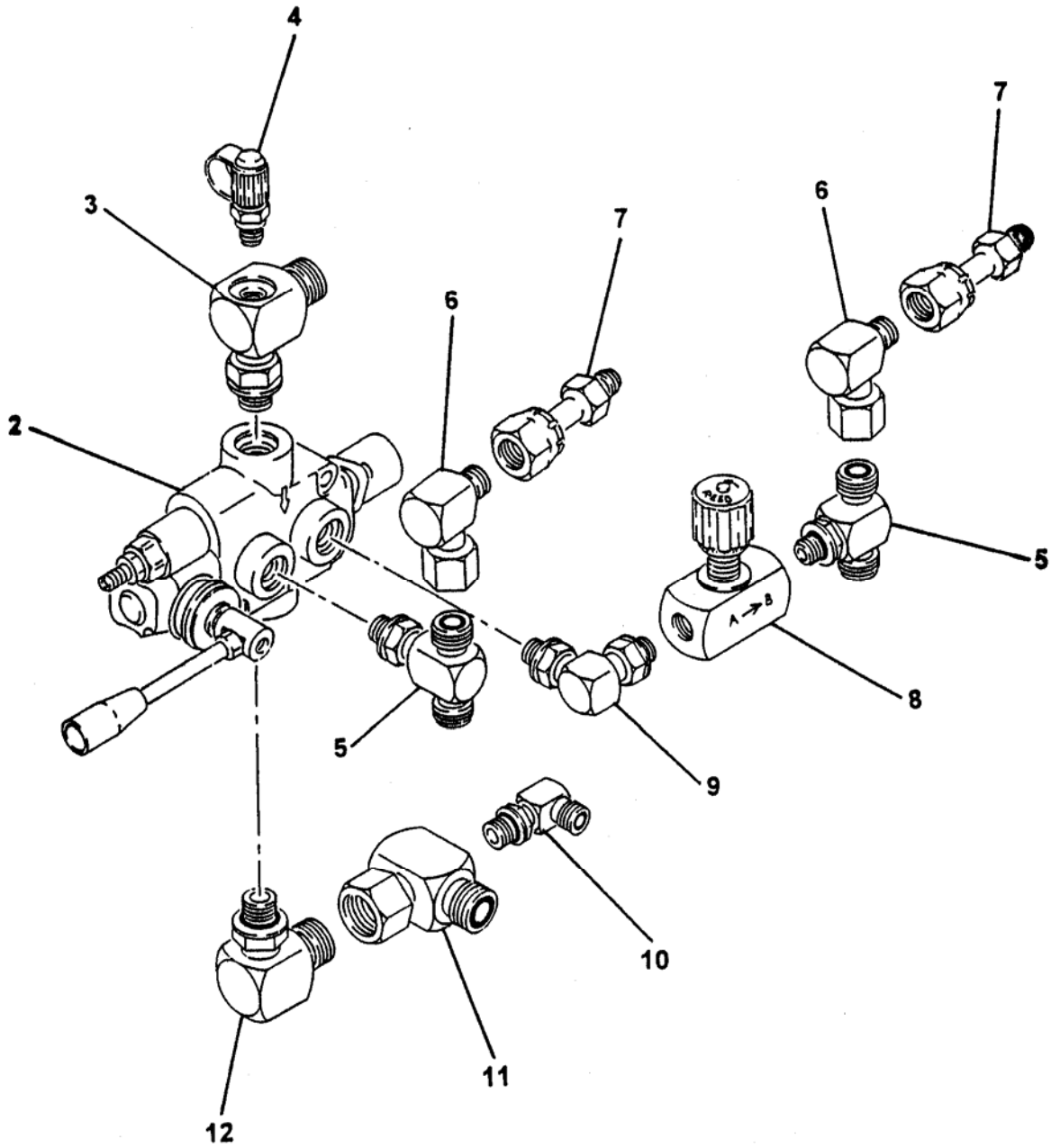

REVISION:





# 1 SPOOL CONTROL VALVE ASSEMBLY

B60  
**PARTS**  
GROUP 80  
FIGURE 16  
PAGE 02

ITEM NO.	REED'S PARTS NO.	DESCRIPTION	QTY
		1 2 3 4 5	
-1	80-16	Assembly, 1 Spool Control Valve (See Group 80, Figure 01 for NHA)	Ref
2	74584	• Sub-Assembly, 1 Spool Control Valve (See Group 80, Figure 17 for DET)	1
3		• Tee, Special Drill	1
4	78593	• Fitting, Mini Check (Port)	1
5		• Tee	2
6		• Fitting, 90	2
7		• Fitting, Connector	2
8		• Controller, Check	1
9		• Fitting, 90	1
10		• Fitting, 90	1
11		• Tee, Special Drill	1
12		• Fitting, 90	1

DASH (-) ITEM NOT ILLUSTRATED



# 1 SPOOL CONTROL VALVE SUB-ASSEMBLY

B60  
PARTS  
GROUP 80  
FIGURE 17  
PAGE 01

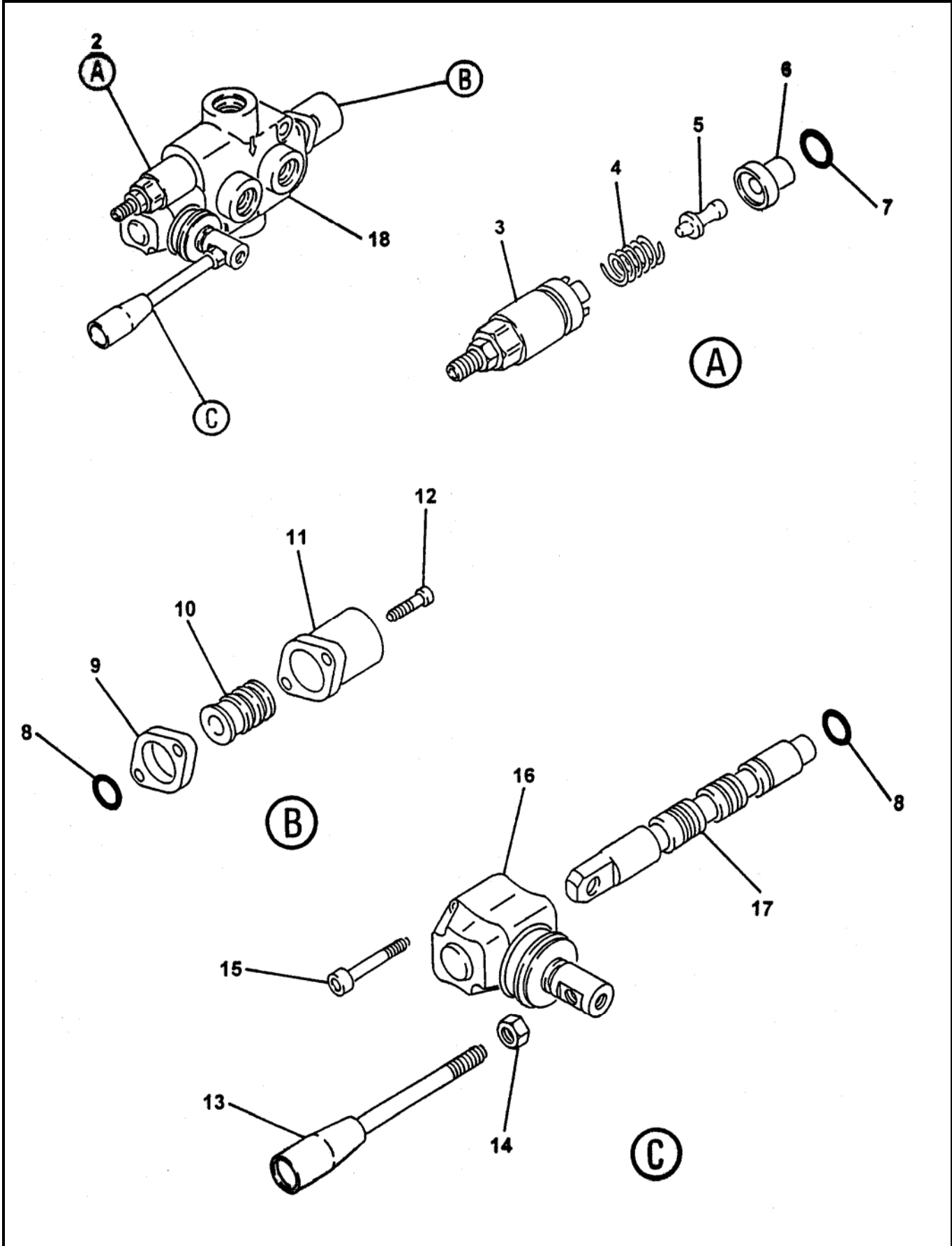

REVISION:



# 1 SPOOL CONTROL VALVE SUB-ASSEMBLY

B60  
PARTS  
GROUP 80  
FIGURE 17  
PAGE 02

ITEM NO.	REED'S PARTS NO.	DESCRIPTION					QTY
		1	2	3	4	5	
-1	74584	Sub-Assembly, 1 Spool Control Valve (See Group 80, Figure 16 for NHA)					Ref
2	85706	• Cartridge, Relief					1
3		• • Kit, Screw					1
4		• • Spring					1
5		• • Pin, Screw Kit					1
6		• • Ring					1
7		• • O-Ring					1
8		• O-Ring					2
9		• Spacer					1
10		• Kit, Spool Control					1
11		• Cap, Spool					1
12		• Screw, SOC (attaching Parts)					2
13		• Handle, Remixer Valve					1
14		• Nut (attaching parts)					1
15		• Screw, SOC					2
16		• Lever, L					1
17		• Spool					1
18		• Body, Valve					1

DASH (-) ITEM NOT ILLUSTRATED



# 2 SPOOL CONTROL VALVE ASSEMBLY

B60  
PARTS  
GROUP 80  
FIGURE 18  
PAGE 01

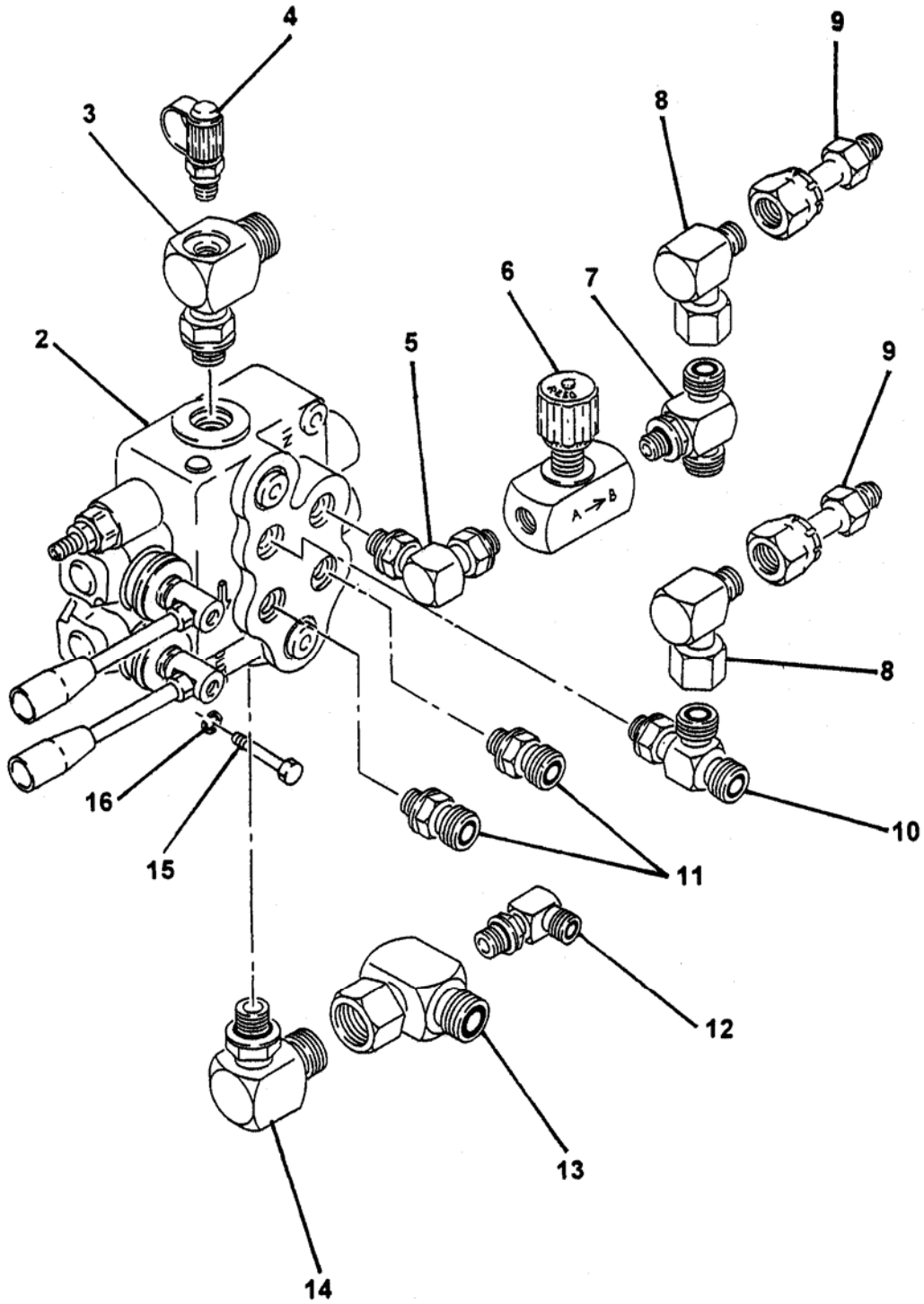

REVISION:



# 2 SPOOL CONTROL VALVE ASSEMBLY

B60  
**PARTS**  
GROUP 80  
FIGURE 18  
PAGE 02

ITEM NO.	REED'S PARTS NO.	DESCRIPTION	QTY
		1 2 3 4 5	
-1	80-18	Assembly, 2 Spool Control Valve (See Group 80, Figure 01 for NHA)	Ref
2	74585	• Sub-Assembly, 2 Spool Control Valve (See Group 80, Figure 20 for DET)	1
3		• Tee, Special Drill	1
4	78593	• Fitting, Mini Check (Port)	1
5		• Fitting, 90	1
6		• Controller, Check	1
7		• Tee	1
8		• Fitting	2
9		• Fitting, Connector	2
10		• Tee	1
11		• Fitting, 90	2
12		• Fitting, 90	1
13		• Tee, Special Drill	1
14		• Fitting, 90	1
15		• Bolt, Hex	2
16		• Washer, SPL Lock	2

DASH (-) ITEM NOT ILLUSTRATED



# 2 SPOOL CONTROL VALVE SUB-ASSEMBLY

B60  
PARTS  
GROUP 80  
FIGURE 19  
PAGE 01

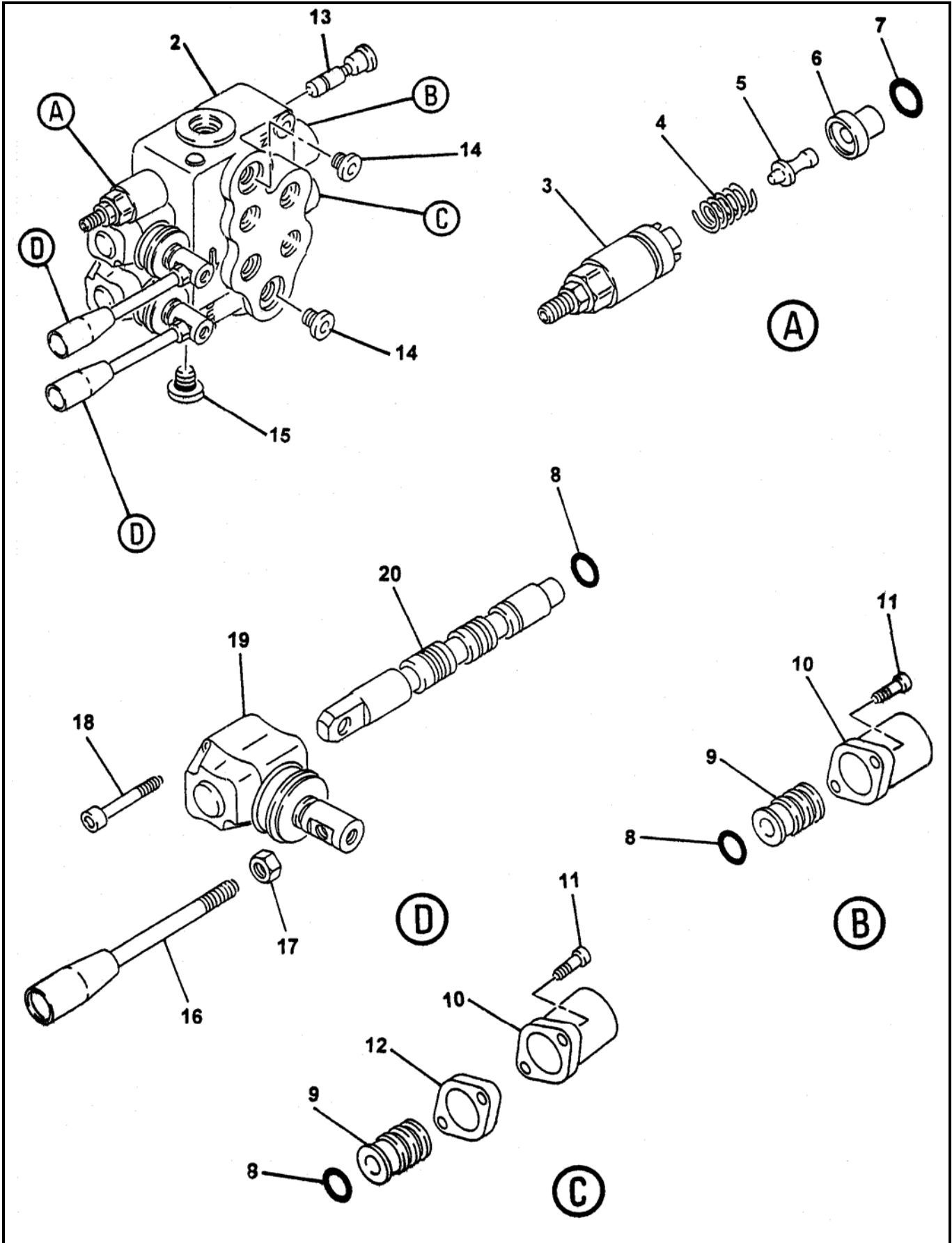

REVISION:



# 2 SPOOL CONTROL VALVE SUB-ASSEMBLY

B60  
**PARTS**  
GROUP 80  
FIGURE 19  
PAGE 02

ITEM NO.	REED'S PARTS NO.	DESCRIPTION					QTY
		1	2	3	4	5	
-1	74585	Sub-Assembly, 2 Spool Control Valve (See Group 80, Figure 18 for NHA)					Ref
2	85706	• Cartridge, Relief					1
3		• • Kit, Screw					1
4		• • Spring					1
5		• • Pin, Screw Kit					1
6		• • Ring					1
7		• • O-Ring					1
8		• O-Ring					4
9		• Kit, Spool Control					2
10		• Cap, Spool					2
11		• Screw, SOC (attaching Parts)					4
12		• Spacer					1
13		• Kit, VRS					1
14		• Plug					2
15		• Plug					1
16		• Handle, Remixer Valve					2
17		• Nut (attaching parts)					2
18		• Screw, SOC					4
19		• Lever, L					2
20		• Spool					2
21		• Body, Valve					1

DASH (-) ITEM NOT ILLUSTRATED



# SIDE DOOR ASSEMBLY

B60  
PARTS  
GROUP 80  
FIGURE 20  
PAGE 01

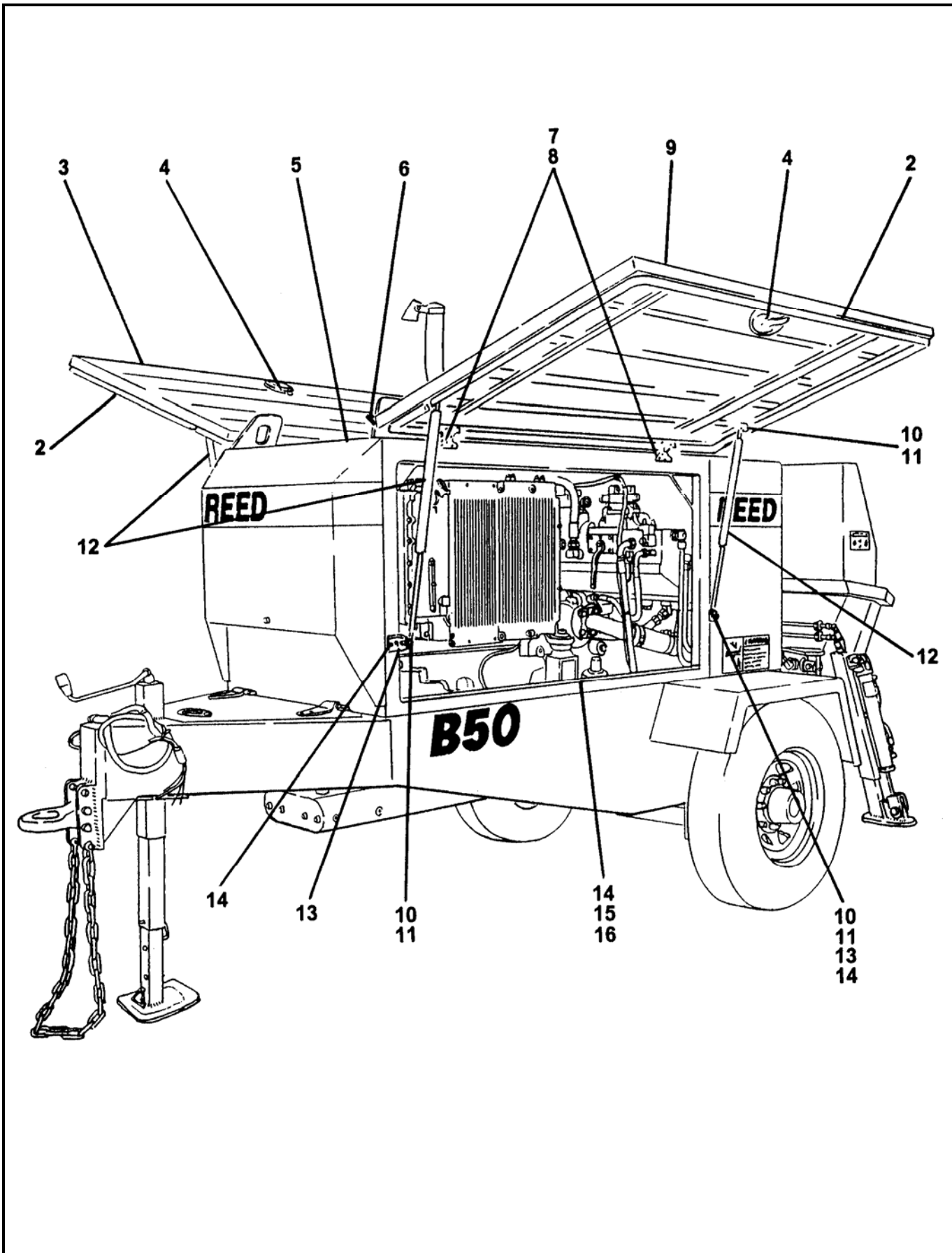

REVISION:





# SIDE DOOR ASSEMBLY

B60  
**PARTS**  
GROUP 80  
FIGURE 20  
PAGE 02

ITEM NO.	REED'S PARTS NO.	DESCRIPTION	QTY
		1 2 3 4 5	
-1	85943	Assembly, B-Series Side Door (See Group 80, Figure 01 for NHA)	Ref
2	73163	• Seal, 3/8 Bulb 15.75 FT Trim	A/R
3	85968	• Weldment, B-Series Right Hand Side Door	1
4	73767	• Latch, D Ring with Key	2
5	86144	• Structure, Lifting	1
6	71364	• Seal, 3/8 Bulb 3.5 FT Trim	A/R
7	85928	• Hinge, Machining	4
8	85945	• Screw, Button Head Cap	12
9	85967	• Weldment, B-Series Left Hand Side Door	1
10	75215	• Stud, Ball	8
11		• Washer, Flat	A/R
12	75214	• Spring, 130 LBS Gas	4
13	85931	• Tab, Frame Gas Spring	2
14	85944	• Screw, Button Head Cap	16
15	85939	• Angle, Left Hand Side Door	1
16	85940	• Angle, Right Hand Side Door	1

DASH (-) ITEM NOT ILLUSTRATED

REVISION:



# 50 FEET STROKE COUNTER CABLE REMOTE CONTROL ASSEMBLY

B60  
PARTS  
GROUP 80  
FIGURE 21  
PAGE 01

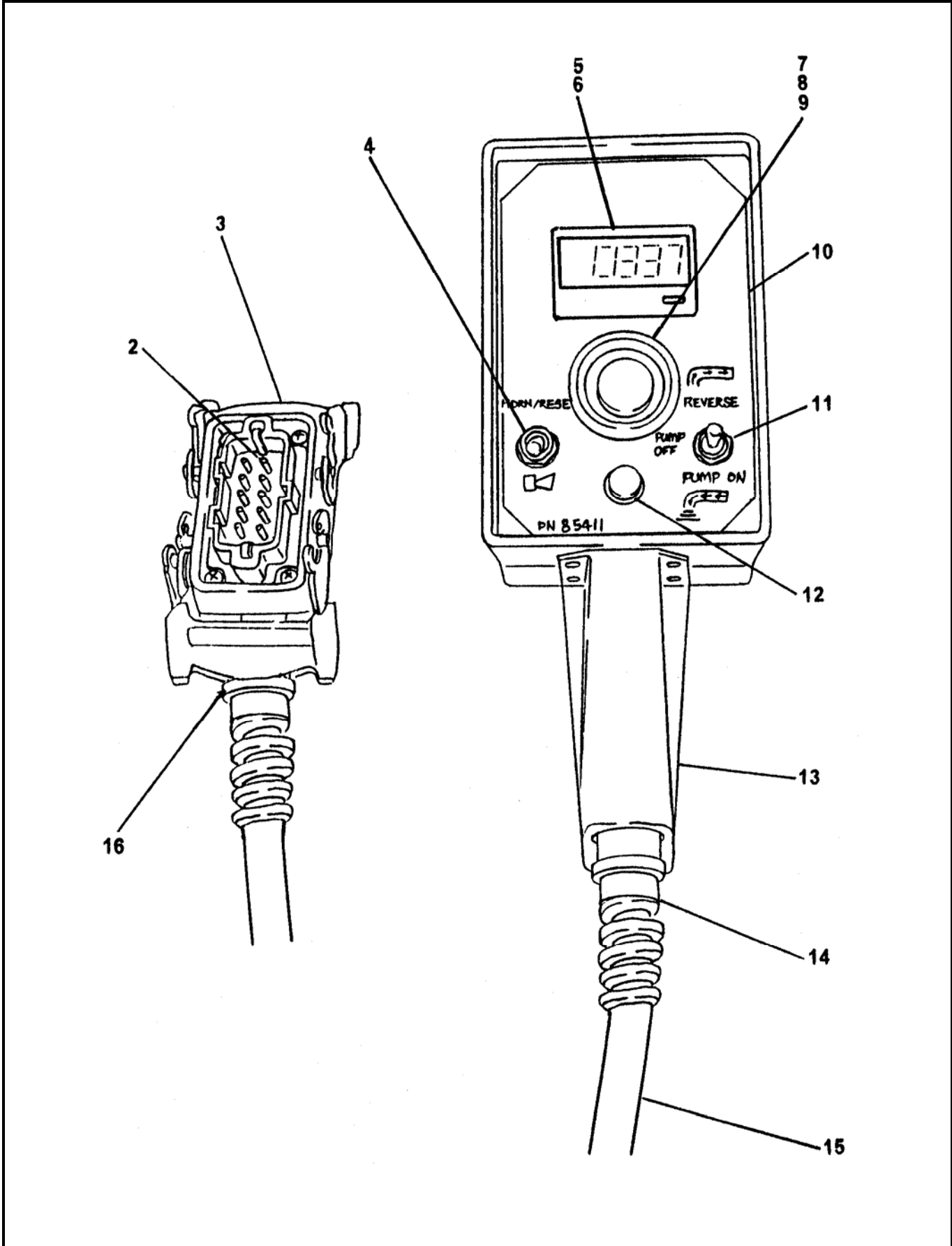

REVISION:



# 50 FEET STROKE COUNTER CABLE REMOTE CONTROL ASSEMBLY

B60  
PARTS  
GROUP 80  
FIGURE 21  
PAGE 02

ITEM NO.	REED'S PARTS NO.	DESCRIPTION	QTY
		1 2 3 4 5	
-1	85960	Assembly, 50 Feet Cable Remote Control with Stroke Counter (See Group 80, Figure 01 for NHA)	Ref
2	79964	• Connector, Insert	1
3	79966	• Connector, Hood	1
4	85347	• Switch, Horn / Reset	1
5	72330	• Counter, Stroke	1
6	74388	• Diode, Stroke Counter	1
7	85342	• Operator, Emergency Stop	1
8	85343	• Block, 1 NC Lighted Contact	1
9	85344	• Bulb, Emergency Stop	1
10	85411	• Decal, C-Series Remote Control Box	1
11	72003	• Switch, Pump On / Reverse	1
12	85355	• Pilot, Light	1
13	85961	• Enclosure, Remote Control	1
14	86133	• Relief, PG-11 Spiral Strain	1
15	85620	• Cable, 50 Feet Remote Control	1
16	86145	• Reducer, PG-16 to PG-11	1
-17	72777	• Resister, Green 100 OHM	1

DASH (-) ITEM NOT ILLUSTRATED

REVISION:



# 100 FEET STROKE COUNTER CABLE REMOTE CONTROL ASSEMBLY

B60  
PARTS  
GROUP 80  
FIGURE 22  
PAGE 01

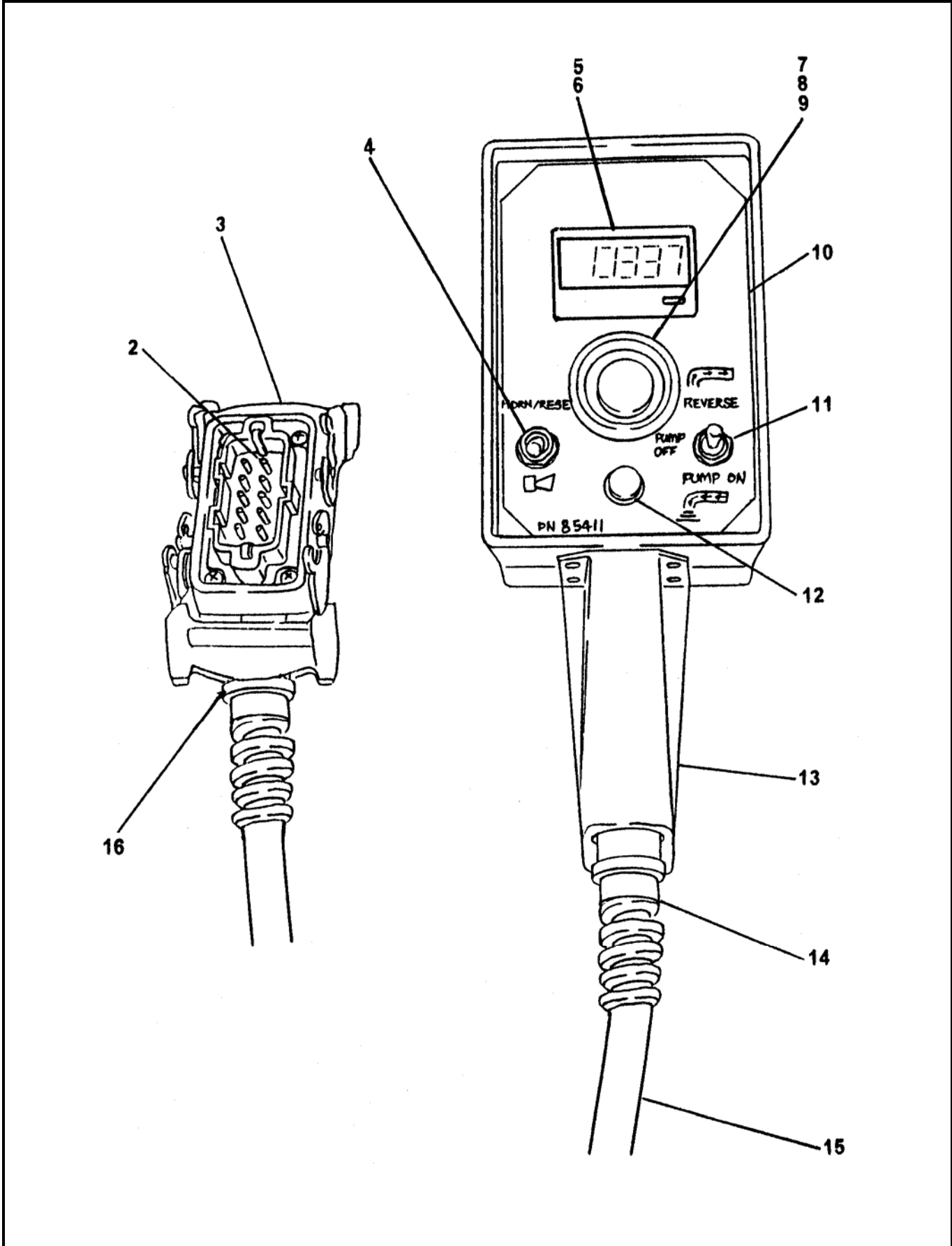

REVISION:



**100 FEET STROKE COUNTER  
CABLE REMOTE CONTROL ASSEMBLY**

**B60**  
**PARTS**  
GROUP 80  
FIGURE 22  
PAGE 02

ITEM NO.	REED'S PARTS NO.	DESCRIPTION	QTY
		1 2 3 4 5	
-1	85960A	Assembly, 100 Feet Cable Remote Control with Stroke Counter (See Group 80, Figure 01 for NHA)	Ref
2	79964	• Connector, Insert	1
3	79966	• Connector, Hood	1
4	85347	• Switch, Horn / Reset	1
5	72330	• Counter, Stroke	1
6	74388	• Diode, Stroke Counter	1
7	85342	• Operator, Emergency Stop	1
8	85343	• Block, 1 NC Lighted Contact	1
9	85344	• Bulb, Emergency Stop	1
10	85411	• Decal, C-Series Remote Control Box	1
11	72003	• Switch, Pump On / Reverse	1
12	85355	• Pilot, Light	1
13	85961	• Enclosure, Remote Control	1
14	86133	• Relief, PG-11 Spiral Strain	1
15	85816	• Cable, 100 Feet Remote Control	1
16	86145	• Reducer, PG-16 to PG-11	1
-17	72777	• Resister, Green 100 OHM	1

DASH (-) ITEM NOT ILLUSTRATED

REVISION: