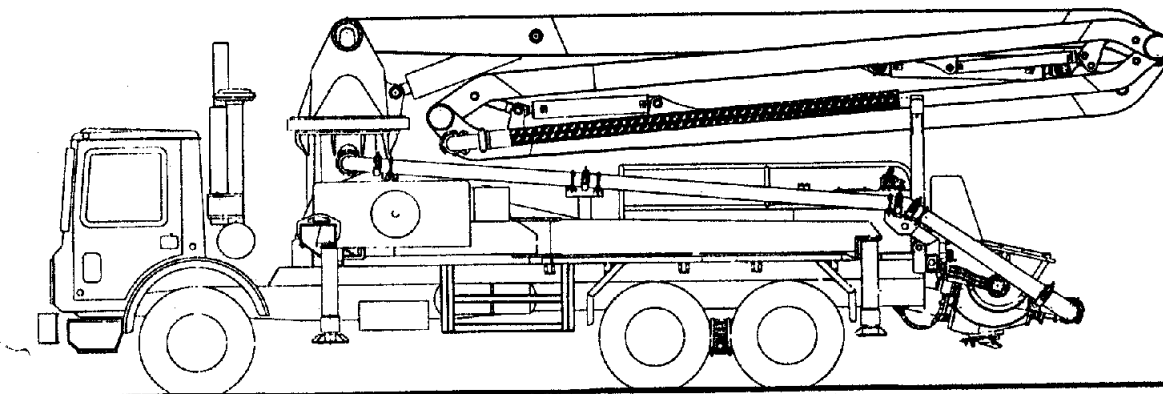

**REED**CONCRETE PLACING  
EQUIPMENT**MODEL XT 32 PARTS MANUAL****PARTS****GROUP 00****FIGURE 00****PAGE 01**

**REED TRUCK MOUNTED COCRETE BOOM PUMP MODEL XT 32 PARTS MANUAL  
CONTAINS THE FOLLOWING GROUPS AND FIGURES:**

**GROUP 00 HOW TO USE PARTS MANUAL**

- FIGURE 00** TABLE OF CONTENTS
- FIGURE 01** HOW TO USE PARTS MANUAL
- FIGURE 02** HOW TO ORDER PARTS

**GROUP 10 FINAL INSTALLATION**

- FIGURE 00** TABLE OF CONTENTS
- FIGURE 01** FINAL INSTALLATION
- FIGURE 02** DECAL ASSEMBLY

**GROUP 20 HOPPER INSTALLATION**

- FIGURE 00** TABLE OF CONTENTS
- FIGURE 01** HOPPER INSTALLATION
- FIGURE 02** REMIXER/WASH CONTROL VALVE ASSEMBLY
- FIGURE 03** AGITATOR ASSEMBLY
- FIGURE 04** AGITATOR DRIVE MOTOR ASSEMBLY
- FIGURE 05** GATE ELBOW ASSEMBLY

**GROUP 30 TANK INSTALLATION**

<b>FIGURE 00</b>	<b>TABLE OF CONTENTS</b>
<b>FIGURE 01</b>	<b>TANK INSTALLATION</b>
<b>FIGURE 02</b>	<b>BOOM HYDRAULIC TANK AND AUXILIARY WATER TANK ASSEMBLY</b>
<b>FIGURE 03</b>	<b>PUMP HYDRAULIC TANK ASSEMBLY</b>
<b>FIGURE 04</b>	<b>WATER TANK ASSEMBLY</b>
<b>FIGURE 05</b>	<b>WATER PUMP MOTOR ASSEMBLY</b>
<b>FIGURE 06</b>	<b>WASH WATER PUMP ASSEMBLY</b>

**GROUP 40 POWER TRAIN INSTALLATION**

<b>FIGURE 00</b>	<b>TABLE OF CONTENTS</b>
<b>FIGURE 01</b>	<b>POWER TRAIN INSTALLATION</b>
<b>FIGURE 02</b>	<b>BOOM PUMP MOTOR ASSEMBLY</b>
<b>FIGURE 03</b>	<b>GEAR BOX ASSEMBLY</b>

**GROUP 50 CONTROLS INSTALLATION**

<b>FIGURE 00</b>	<b>TABLE OF CONTENTS</b>
<b>FIGURE 01</b>	<b>CONTROLS INSTALLATION</b>
<b>FIGURE 02</b>	<b>RADIO REMOTE CONTROL ASSEMBLY</b>
<b>FIGURE 03</b>	<b>WIRE REMOTE CONTROL ASSEMBLY</b>
<b>FIGURE 04</b>	<b>BOOM FUNCTION CONTROL VALVE ASSEMBLY</b>
<b>FIGURE 05</b>	<b>SHUNT ASSEMBLY</b>
<b>FIGURE 06</b>	<b>BOOM PUMP CONTROL PANEL ASSEMBLY</b>

**GROUP 60 PUMPING TRAIN INSTALLATION**

<b>FIGURE 00</b>	<b>TABLE OF CONTENTS</b>
<b>FIGURE 01</b>	<b>PUMPING TRAIN INSTALLATION</b>
<b>FIGURE 02</b>	<b>SWING VALVE ASSEMBLY (I)</b>
<b>FIGURE 03</b>	<b>SWING VALVE ASSEMBLY (II)</b>
<b>FIGURE 04</b>	<b>CONCRETE CYLINDER ASSEMBLY</b>
<b>FIGURE 05</b>	<b>WATER BOX ASSEMBLY</b>
<b>FIGURE 06</b>	<b>HYDRAULIC DRIVE CYLINDER ASSEMBLY</b>
<b>FIGURE 07</b>	<b>DRIVE CYLINDER SUB-ASSEMBLY</b>
<b>FIGURE 08</b>	<b>CENTRAL LUBRICATION SYSTEM</b>
<b>FIGURE 09</b>	<b>VALVES INSTALLATION</b>
<b>FIGURE 10</b>	<b>SWING CIRCUIT CYLINDER VALVE ASSEMBLY</b>
<b>FIGURE 11</b>	<b>DIRECTIONAL CONTROL VALVE SUB-ASSEMBLY</b>
<b>FIGURE 12</b>	<b>UNLOADER MANIFOLD SYSTEM</b>

**GROUP 70 FRAME AND SUPPORT INSTALLATION**

<b>FIGURE 00</b>	<b>TABLE OF CONTENTS</b>
<b>FIGURE 01</b>	<b>FRAME AND SUPPORT INSTALLATION</b>
<b>FIGURE 02</b>	<b>ROTATING HEAD ASSEMBLY</b>
<b>FIGURE 03</b>	<b>MOTOR AND REDUCTION ASSEMBLY</b>
<b>FIGURE 04</b>	<b>ROTATION SUPPORT ASSEMBLY</b>
<b>FIGURE 05</b>	<b>SUPPORT FRAME STABILIZERS ASSEMBLY</b>
<b>FIGURE 06</b>	<b>FRONT STABILIZERS HORIZONTAL JACK ASSEMBLY</b>
<b>FIGURE 07</b>	<b>FRONT RIGHT STABILIZER JACK ASSEMBLY</b>
<b>FIGURE 08</b>	<b>FRONT LEFT AND REAR STABILIZER JACKS ASSEMBLY</b>
<b>FIGURE 09</b>	<b>REAR STABILIZERS HORIZONTAL JACK ASSEMBLY</b>

**GROUP 80 OPTIONAL INSTALLATION**

<b>FIGURE 00</b>	<b>TABLE OF CONTENTS</b>
<b>FIGURE 01</b>	<b>HOPPER VIBRATOR ASSEMBLY</b>
<b>FIGURE 02</b>	<b>LUBRICATION PUMP ASSEMBLY</b>

**GROUP 90 BOOM INSTALLATION**

<b>FIGURE 00</b>	<b>TABLE OF CONTENTS</b>
<b>FIGURE 01</b>	<b>BOOM INSTALLATION</b>
<b>FIGURE 02</b>	<b>FIRST BOOM ASSEMBLY</b>
<b>FIGURE 03</b>	<b>SECOND BOOM ASSEMBLY</b>
<b>FIGURE 04</b>	<b>THIRD BOOM ASSEMBLY</b>
<b>FIGURE 05</b>	<b>FOURTH BOOM ASSEMBLY</b>
<b>FIGURE 06</b>	<b>FIRST BOOM PISTON ASSEMBLY</b>
<b>FIGURE 07</b>	<b>SECOND BOOM PISTON ASSEMBLY</b>
<b>FIGURE 08</b>	<b>THIRD BOOM PISTON ASSEMBLY</b>
<b>FIGURE 09</b>	<b>FOURTH BOOM PISTON ASSEMBLY</b>
<b>FIGURE 10</b>	<b>CONCRETE PIPELINE ASSEMBLY</b>

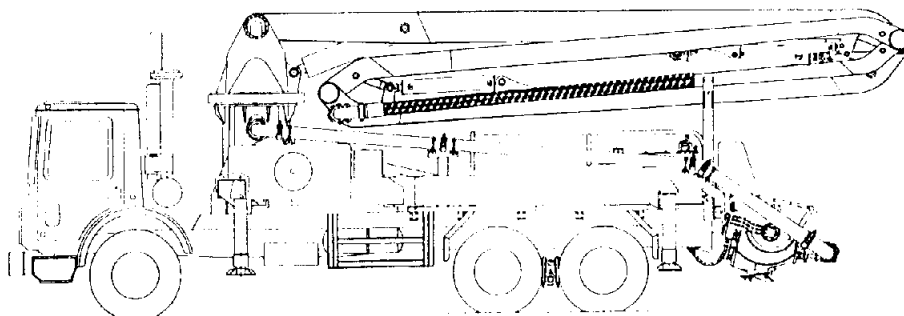

**I. PURPOSE**

This parts manual is prepared, issued and/or revised by **REED** Manufacturing, for the exclusive use of its customers and is intended for use in provisioning, requisitioning, storing and issuing replaceable **REED** truck mounted concrete boom pump model **XT 32**.

The contents are proprietary to **REED** and are subject to change without notice. The use of any part of this document by any other person or persons or for any other purpose without the written consent of **REED** is expressly prohibited. In addition, **REED** expressly disclaims any and all responsibility arising in or any way related to such **REED'S** prior written consent thereto.

The parts number content of this document, arrangement and breakdown sequence of items is compatible with Military Standard (**MS**) and Air Transport Association Specification (**ATA**).

**II. GENERAL SYSTEM OF ASSEMBLY ORDER - Detailed Parts List (Refer to Next Page)**

1. This area refers to the corresponding illustration

**GROUP - FIGURE - PAGE**

- A. **GROUP** should be divided with:

00	MODEL <b>XT 32</b> PARTS MANUAL
10	FINAL INSTALLATION
20	HOPPER INSTALLATION
30	TANK INSTALLATION
40	POWER TRAIN INSTALLATION
50	CONTROL INSTALLATION
60	PUMPING TRAIN INSTALLATION
70	FRAME AND SUPPORT INSTALLATION
80	OPTIONAL INSTALLATION
90	BOOM INSTALLATION

- B. **FIGURE** belong to the group. Please see page of contents and each group.

- C. **PAGE** numbers follow to the right of each figure number.

2. The **ITEM NUMBER** corresponds to the item number shown for the part in illustration. Parts with item number preceded by a dash (such as: -1, -5, -12 etc.) are not illustrated.

3. **PARTS NUMBERS** that carry a **REED** part number.

**REED**CONCRETE PLACING  
EQUIPMENT**HOW TO USE PARTS MANUAL****PARTS**

GROUP 00

FIGURE 01

PAGE 02

2

3

4

5

1

**REED**CONCRETE PLACING  
EQUIPMENT**HYDRAULIC PUMPING ASSEMBLY**PARTS  
GROUP 60  
FIGURE 06  
PAGE 02

ITEM NO.	REED'S PARTS NO.	DESCRIPTION					QTY
		1	2	3	4	5	
-1	60-06	Assembly, Hydraulic Pumping (See Group 20, Figure 01 for NHA)					Ref
2	78354	• Cup, Piston					2
3	78444	• Coupler					2
4	78352	• Coupling, Dog bone					4
5		• Bolt, 1/2 x 4 (attaching parts)					8
6		• Nut, 1/2 (attaching parts)					8
7	78443	• Bone, Dog					2
8		• Bolt, 5/8 x 2					6
9	78442	• Coupler					2
10	78438	• Assembly, Hydraulic Cylinder (See Group 60, Figure 07 for DET)					1
11		• Nut (attaching parts)					16
12		• Washer (attaching parts)					16
13	77617	• Bolt (attaching parts)					16
14		• Elbow, 90 FS6802-16-16					4
15	79343	• Assembly, Hose					2
16	78593	• Fitting, MiniCheck (Port)					2
17		• Elbow, 90 FS6802-06-06					4
18		• Fitting, STR FS6400-06-06					4
19	79344	• Assembly, Hose					2
20		• Elbow, 90 FS6801-06-06					4
21		• Valve, Check					4
22		• Elbow, 90 MBSMB90-06-06					4
23		• Clamp					3
24	79326	• Tube, Wire					1
25	79345	• Assembly, Tube					2
26	78417	• Cable					2
27	72010	• Loom, 1/2 Flex					A/R
28		• Pin, 1/4 x 20					4
29	79285	• Cover, Proximity Switch					2
30	78416	• Switch, Proximity					2
31	79327	• Plate, End					1
32		• Washer, 1 Lock (attaching parts)					8
33		• Bolt, 1 x 2 Course (attaching parts)					8

DASH (-) ITEM NOT ILLUSTRATED

REVISION

2

3

4

5

REVISION:

# HOW TO USE PARTS MANUAL

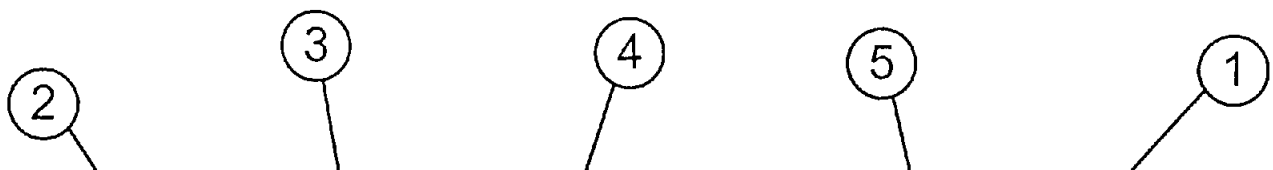

## HYDRAULIC PUMPING ASSEMBLY

ITEM NO.	REED'S PARTS NO.	DESCRIPTION					QTY
		1	2	3	4	5	
1	60-00	Assembly, Hydraulic Pumping (See Group 20, Figure 01 for NHA)					Ref
2	78354	• Cup, Piston					2
3	78444	• Coupler					2
4	78352	• Coupling, Dog bone					4
5		• Bolt 1/2 x 4 (attaching parts)					8
6		• Nut, 1/2 (attaching parts)					8
7	78443	• Bone, Dog					2
8		• Bolt 5/8 x 2					6
9	78442	• Coupler					2
10	78438	• Assembly, Hydraulic Cylinder (See Group 60, Figure 07 for DET)					1
11		• Nut (attaching parts)					16
12		• Washer (attaching parts)					16
13	77617	• Bolt (attaching parts)					16
14		• Elbow, 90 FS6802-16-16					4
15	79343	• Assembly, Hose					2
16	78593	• Fitting, MiniCheck (Port)					2
17		• Elbow, 90 FS6802-06-06					4
18		• Fitting, STR FS6400-06-06					4
19	79344	• Assembly, Hose					2
20		• Elbow, 90 FS6801-06-06					4
21		• Valve, Check					4
22		• Elbow, 90 MIB90-06-06					4
23		• Clamp					3
24	79326	• Tube, Wire					1
25	79345	• Assembly, Tube					2
26	78417	• Cable					2
27	72010	• Loom, 1/2 Flex					A/R
28		• Pin, 1/4 x 20					4
29	79285	• Cover, Proximity Switch					2
30	78416	• Switch, Proximity					2
31	79327	• Plate, End					1
32		• Washer, 1 Lock (attaching parts)					8
33		• Bolt, 1 x 2 Course (attaching parts)					8

DASH (-) ITEM NOT ILLUSTRATED

REVISION



**4. DESCRIPTION**

A. The **INDENTURE SYSTEM** used in the parts list shows the relationship of one part to another. For a given item, the number of indentures depicts the relationship of the item to the components of the item as follows:

- 1   2   3   4   5  
Assembly (or Installation)
- Detail part of assembly
- Sub-assembly
- Attaching parts for sub-assembly
- ● Detail part of sub-assembly
- ● Sub-sub-assembly
- ● Attaching parts for sub-sub-assembly
- ● ● Detail part of sub-sub-assembly
- ● ● Sub-sub-sub-assembly
- ● ● Attaching parts of sub-sub-sub-assembly
- ● ● ● Detail part of sub-sub-sub-assembly

B. "See Group 30, Figure 01 For **NHA**"  
Identifies the illustrated parts chapter location; indicates where the Next Higher Assembly (**NHA**) of the item shown.

C. "See Group 30, Figure 03 For **DET**"  
Identifies the illustrated parts chapter location; indicates where the item and its Detailed Breakdown (**DET**) is shown.

D. "See Group 30, Figure 05 for **REF**" or "See Vendor Chapter For **REF**"  
Identifies the illustrated parts chapter where the part is, and if listed and illustrated in Vendor Chapter. It is used as a cross-reference (**REF**).

**5. QUANTITY**

A. Reference (**REF**) indicates the items that is listed previously in the Next Higher Assembly (**NHA**) and then again in this figure.

B. As Required (**A/R**) indicates the parts that is used in a quantity as required.

C. A number entry indicates the quantity of the part used in its next higher application.

6. Functionally related assemblies are illustrated in phantom ( — — — — ) but not listed on the detail parts list page.

**HOW TO ORDER PARTS**

1. Always give serial number and model of **REED XT 32**. (Refer to each unit name plate shown below). **NOTE:** This manual is being released to cover unit starting with serial number **SER. NO.: 97-162-XT32** to current production. Some components used on earlier units differ from current productions. Where this occurs, the part is identified by a serial number (SER. NO.).

<b>REED</b>		PHONE (909) 364-2100		CE
13822 OAKS AVENUE CHINO, CA 90710 USA		FAX (909) 364-2140		
MODEL	<input type="text"/>	SERIAL NO.	<input type="text"/>	
HYD. PRESSURE	<input type="text"/>	PSI	<input type="text"/>	BAR
ELECTRIC MOTOR/ ENGINE SPEED	<input type="text"/>	RPM	<input type="text"/>	VOLTS
VEHICLE WEIGHT (APPROX.)	<input type="text"/>	LBS	<input type="text"/>	KG

75099A

2. Always specify part number and complete name of parts ordered.
- A. Turn to table of content in the desired Installation.  
Refer to main group in which part should be listed.

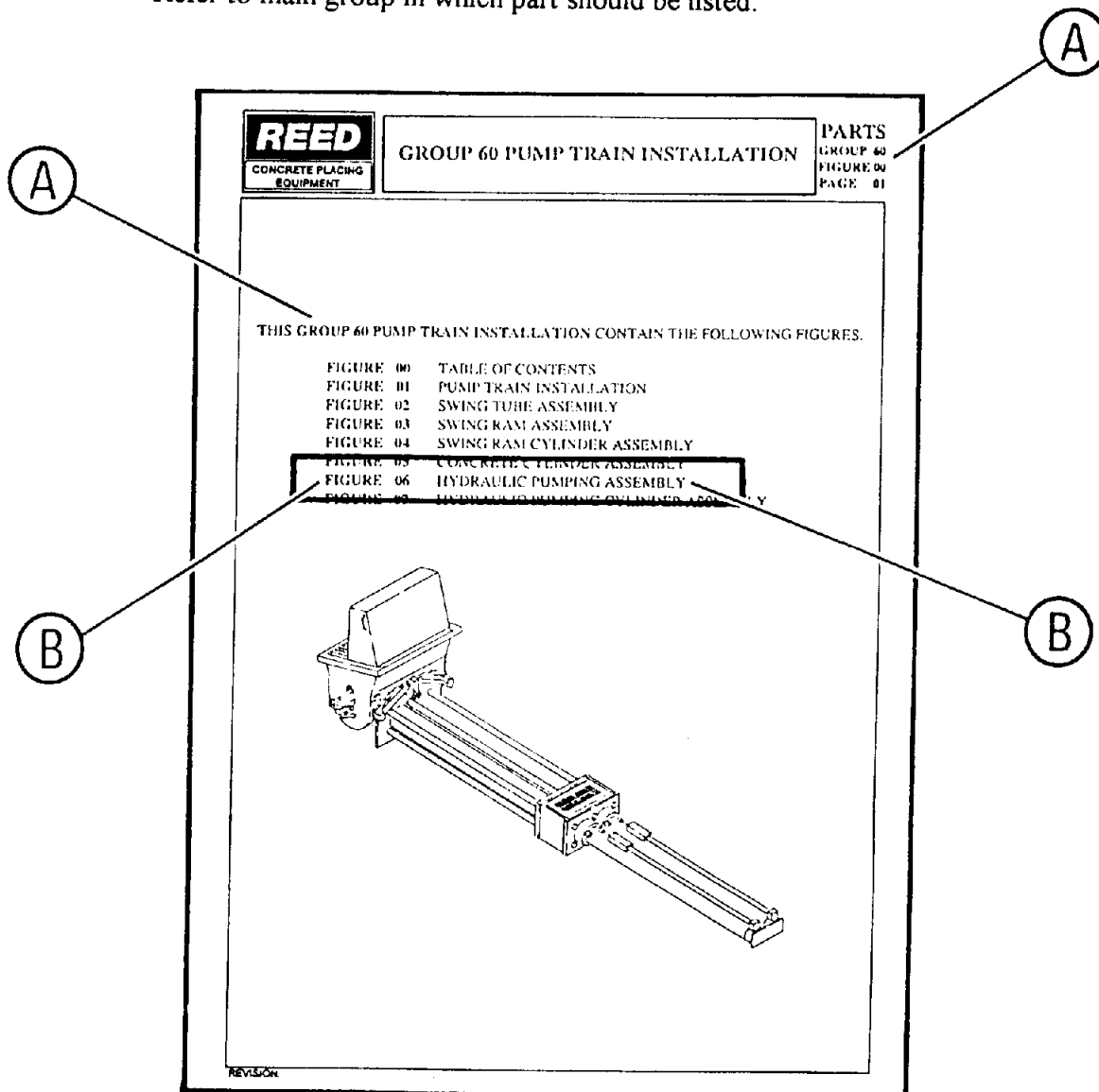



# REED

CONCRETE PLACING  
EQUIPMENT

## HOW TO ORDER PARTS

PARTS  
GROUP 00  
FIGURE 02  
PAGE 02

REED  
CONCRETE PLACING  
EQUIPMENT

### HYDRAULIC PUMPING ASSEMBLY

PARTS  
GROUP 00  
FIGURE 04  
PAGE 01

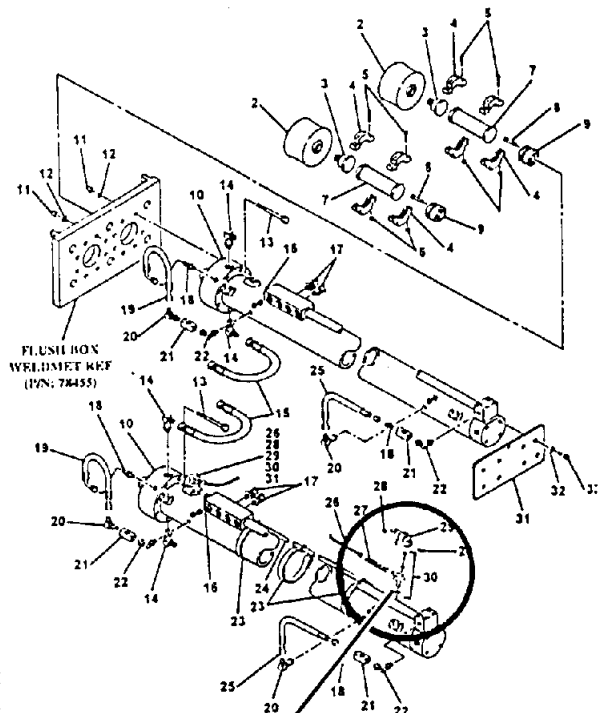

FLUSH BOX  
WELD MET REF  
(PN: 78455)

REVISION:

REED  
CONCRETE PLACING  
EQUIPMENT

### HYDRAULIC PUMPING ASSEMBLY

PARTS  
GROUP 00  
FIGURE 04  
PAGE 02

ITEM NO.	REED'S PARTS NO.	DESCRIPTION	QTY
1	68406	Assembly, Hydraulic Pumping (See Catalog 20, Figure 1 for NHA)	Ref
2	78354	* Cup, Piston	2
3	78484	* Coupler	2
4	78352	* Coupling, Drive	4
5		* Bolt, 1/2 x 4 (attaching parts)	8
6		* Nut, 1/2 (attaching parts)	8
7	78441	* Hose, Eng	2
8		* Bolt, 3/8 x 2	6
9	78442	* Coupler	2
10	78416	* Assembly, Hydraulic Cylinder (See Catalog 20, Figure 03 for DET)	1
11		* Nut (attaching parts)	16
12		* Washer (attaching parts)	16
13	77617	* Bolt, Eng (attaching parts)	16
14		* Elbow, 1/2 FNAB12-16-16	4
15	79143	* Assembly, Hose	2
16	78593	* Fitting, Misc Check (Part)	2
17		* Elbow, 1/2 FNAB12-16-16	4
18		* Fitting, NPT FNAB12-16-16	4
19	79144	* Assembly, Hose	2
20		* Elbow, 1/2 FNAB12-16-16	4
21		* Bolt, Check	4
22		* Elbow, 1/2 FNAB12-16-16	4
23		* Clamp	1
24	79126	* Tube, Wire	1
25	79145	* Assembly, Tube	2
26	78417	* Cable	2
27	72010	* Lasso, 1/2 Flex	A/R
28		* Pin, 1/4 x 2 1/2	4
29	79285	* Cover, Pressure Switch	2
30	78416	* Switch, Pressure	2
31	78455		
32		* Washer, 1/2 Lock (attaching parts)	8
33		* Bolt, 1/2 x 2 Course (attaching parts)	8

UNLESS OTHERWISE ILLUSTRATED

REVISION:

- B. Find title of figure in which the part should be shown. Note figure number.
- C. Turn to corresponding page, find the group and figure.
- D. Check your required part and its attaching parts and match with illustration page.
- E. Refer to corresponding item number in the part list page. Part numbers are located in the part number column.
- F. When ordering variable or optional miscellaneous parts which are not found this in parts chapter, follow the above outlined procedure of how to order parts.
  - 1). When applicable, give model and serial number of the component for which parts are desired.
  - 2). In a specific, difficult to describe situation, a marked-up photograph or detailed sketch would be helpful.

REVISION:



## HOW TO ORDER PARTS

**PARTS**  
GROUP 00  
FIGURE 02  
PAGE 03

3. Do not designate quantity by "set". State specifically how many parts are wanted.
4. Always give complete address and full shipping instructions. Specify shipping instructions, truck freight, air freight. United Parcel Service (UPS), or Air Borne Express, and DHL are available in designated areas.

### 5. TO ORDER

#### A. BY MAIL

Attention: Parts Department

**REED**

13822 Oaks Avenue  
Chino, CA. 91710

#### B. BY FAX

(909) 364 - 2140

#### C. BY PHONE

(909) 364 - 2100

6. Parts return without authorization will not be accepted. If it is necessary to return parts for any reason, written authorization may be obtained from **REED** Parts Department, Chino, CA. 91710. A Parts Return Authorization form is provided when **REED** deems its necessary to have the part returned for evaluation.

The form is issued by the Warranty of Parts Department of **REED**.

- A. The form will be filled by **REED** unless requesting necessary information and you will receive a copy as well as shipping tag.
- B. Attach shipping tag to part insert return original invoice.
- C. Ship part to **REED PREPAID**.
- D. Part must be returned to **REED** within 30 days from date of authorization.

**GROUP 10 FINAL INSTALLATION CONTAINS THE FOLLOWING FIGURES:**

- FIGURE 00** TABLE OF CONTENTS
- FIGURE 01** FINAL INSTALLATION
- FIGURE 02** DECAL ASSEMBLY

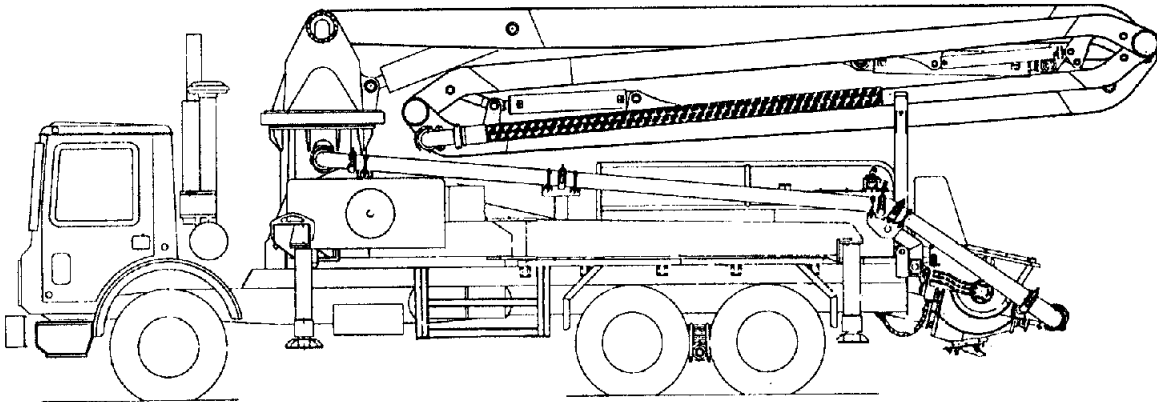

**XT 32 FINAL ASSEMBLY**

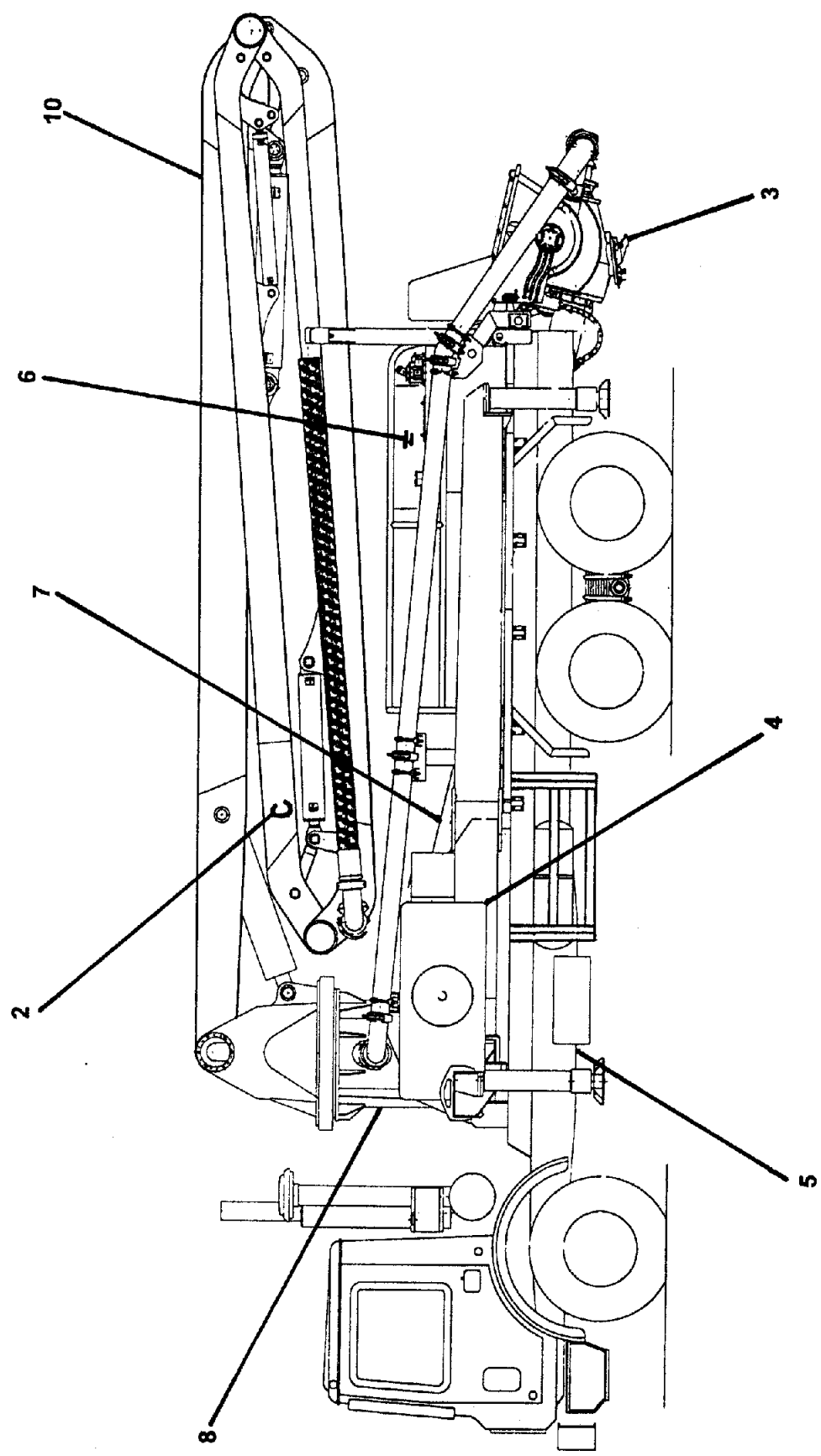

REVISION:

**REED**CONCRETE PLACING  
EQUIPMENT**XT 32 FINAL ASSEMBLY****PARTS  
GROUP 10  
FIGURE 01  
PAGE 02**

ITEM NO.	REED'S PARTS NO.	DESCRIPTION	QTY
		1 2 3 4 5	
-1	XT 32	Installation, XT 32 Final	Ref
2	10-02	• Assembly, Decal (See Group 10, Figure 02 for DET)	1
3	20-01	• Installation, Hopper (See Group 20, Figure 01 for DET)	1
4	30-01	• Installation, Tank (See Group 30, Figure 01 for DET)	1
5	40-01	• Installation, Power Train (See Group 40, Figure 01 for DET)	1
6	50-00	• Installation, Control (See Group 50, Figure 01 for DET)	1
7	60-01	• Installation, Pumping Train (See Group 60, Figure 01 for DET)	1
8	70-01	• Installation, Frame and Support (See Group 70, Figure 01 for DET)	1
-9	80-00	• Installation, Optional (See Group 80, Figure 00 for DET)	1
10	90-01	• Installation, Boom (See Group 90, Figure 01 for DET)	1

DASH (-) ITEM NOT ILLUSTRATED

REVISION:

# REED

CONCRETE PLACING  
EQUIPMENT

## DECAL ASSEMBLY

PARTS  
GROUP 20  
FIGURE 02  
PAGE 01

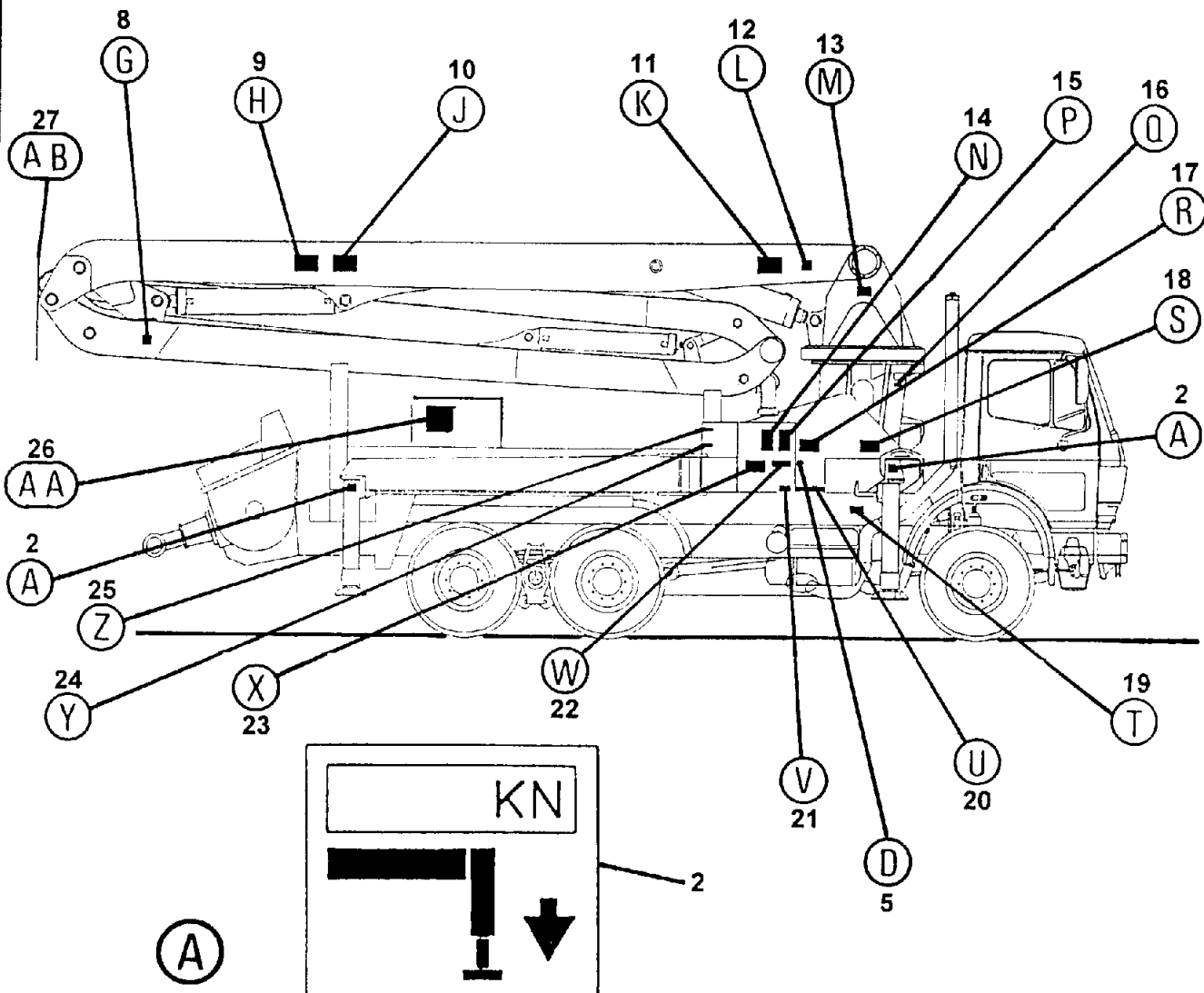
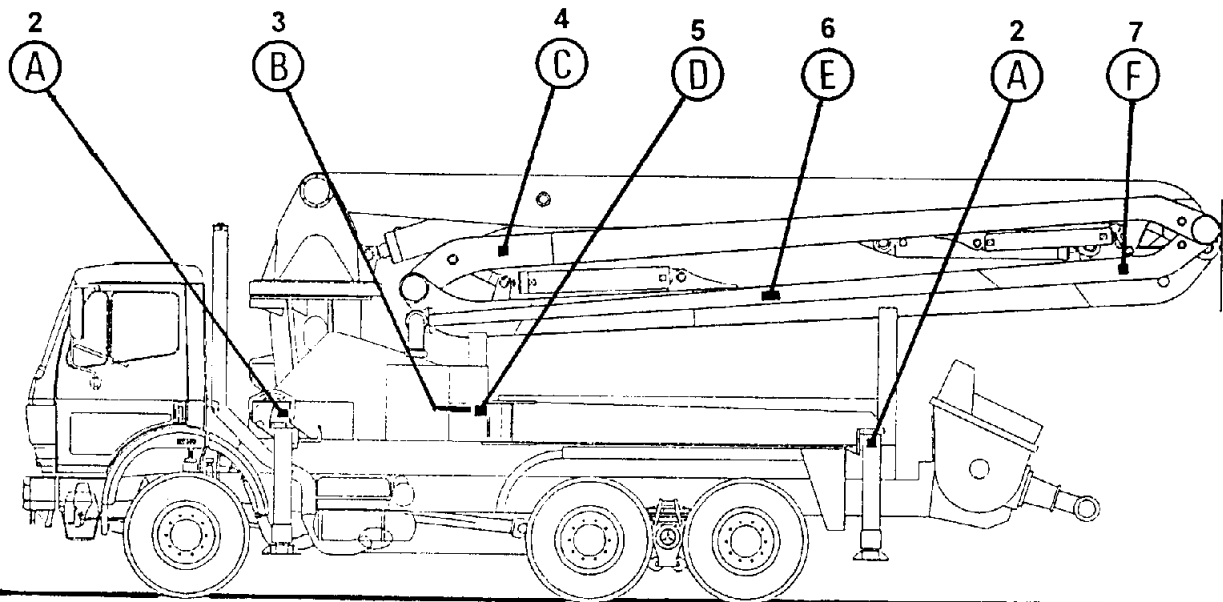

REVISION:

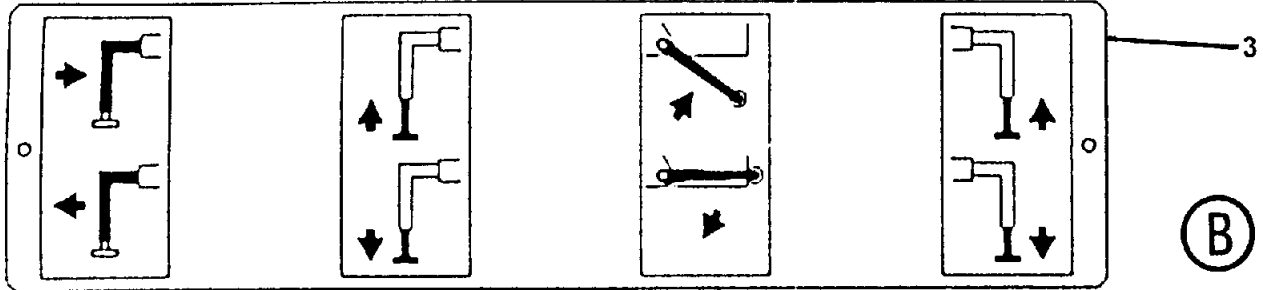
**REED**CONCRETE PLACING  
EQUIPMENT**DECAL ASSEMBLY****PARTS  
GROUP 10  
FIGURE 02  
PAGE 02**

ITEM NO.	REED'S PARTS NO.	DESCRIPTION					QTY
		1	2	3	4	5	
-1	10-02	Assembly, Decal (See Group 10, Figure 01 for NHA)					Ref
2	C-4V112	• Plate, Maximum Stabilizers Loads					4
3	C-3V101	• Plate, Right Side Stabilizers					1
4	C-4V115	• Decal, C Letter Adhesive					1
5	C-4V121	• Plate, Electric Switch Lever					2
6	C-4V110	• Plate, Maximum Hose Length					1
7	C-4V116	• Decal, D Letter Adhesive					1
8	C-4V114	• Decal, B Letter Adhesive					1
9	C-4V106	• Plate, Never Use As Crane					1
10	C-4V107	• Plate, Danger Of Falling Object					1
11	C-4V105	• Plate, Death Hazard					1
12	C-4V113	• Decal, A Letter Adhesive					1
13	C-4V199	• Plate, Machine Identification Data					1
14	C-3V119	• Plate, Operate Field					1
15	C-4V118	• Plate, Instruction For Use					1
16	C-4V123	• Plate, Greaser					1
17	C-4V111	• Plate, Danger Of Crushing					1
18	C-4V108	• Plate, Maximum Inclination					1
19	C-4V198	• Plate, Chassis Identification Data					1
20	C-4V120	• Plate, Hydraulic Distributor					1
21	C-4V127-4V128	• Plate, Warning Stabilizers					1
22	C-3V102	• Plate, Left Side Stabilizers					1
23	C-4V109	• Plate, Danger Of Crushing					1
24	C-4V126	• Plate, Minimum Lever					1
25	C-4V125	• Plate, Maximum Lever					1
26	78550	• Decal, Control Box Panel					1
27		• Plate, Danger Oversize, Safety Drive					1

DASH (-) ITEM NOT ILLUSTRATED

REVISION:

DECAL ASSEMBLY

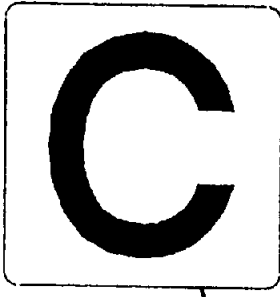

(C)

4

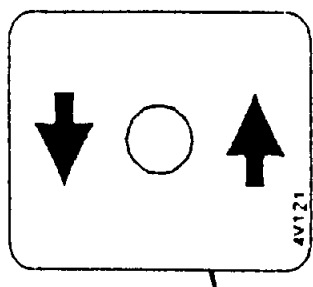

(D)

5

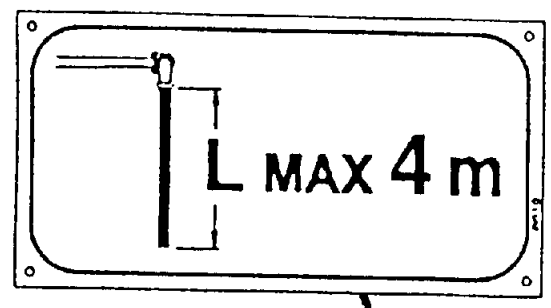

(E)

6

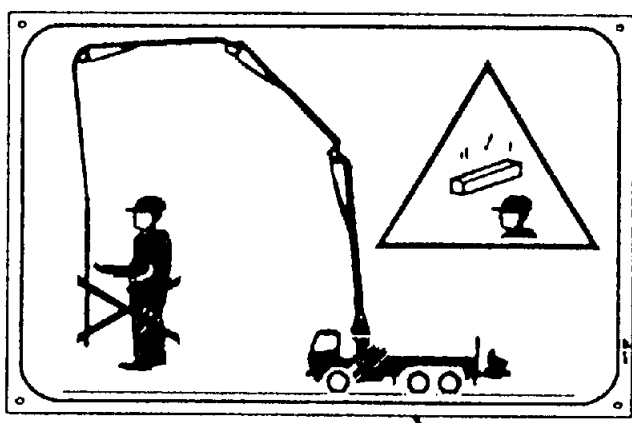

(J)

10

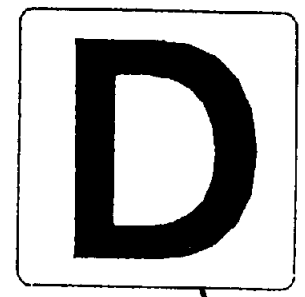

(F)

7

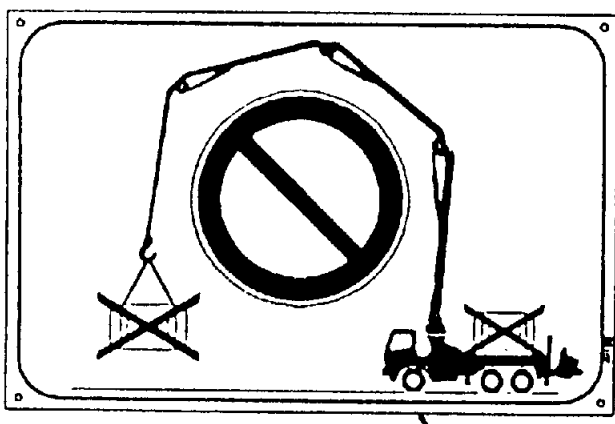

(H)

9

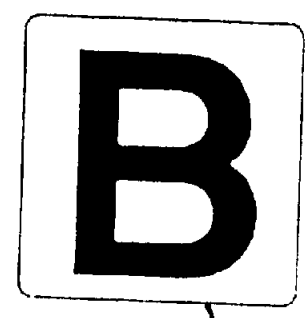

(G)

8



**REED**

CONCRETE PLACING  
EQUIPMENT

DECAL ASSEMBLY

PARTS  
GROUP 10  
FIGURE 02  
PAGE 04

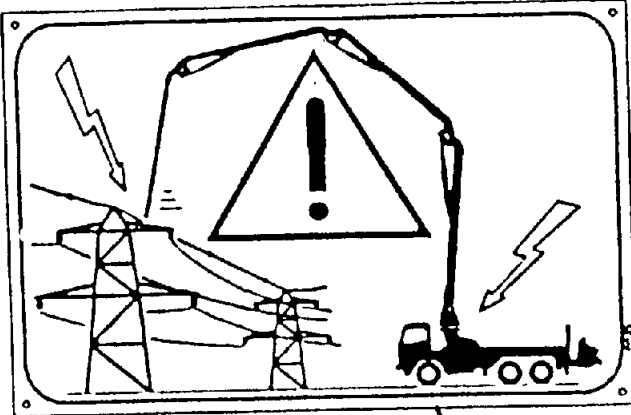

(K)

11

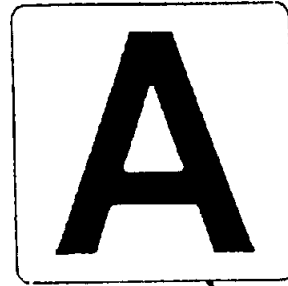

(L)

12

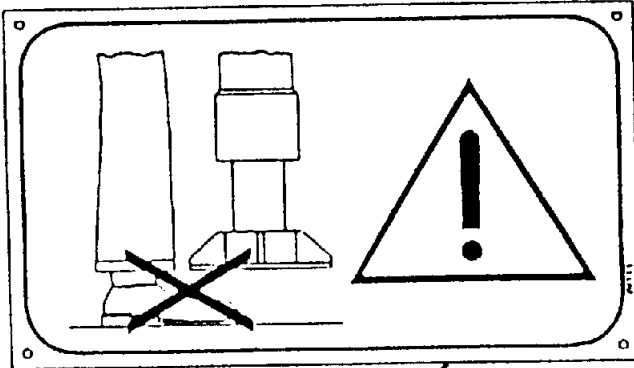

(R)

17

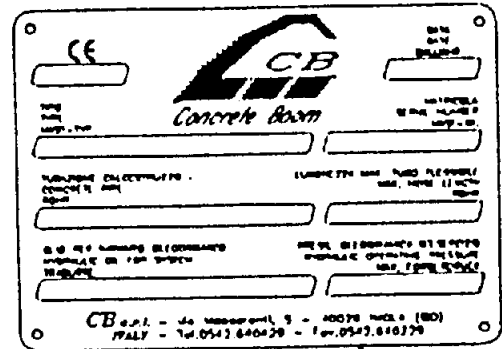

(M)

13



(Q)

16

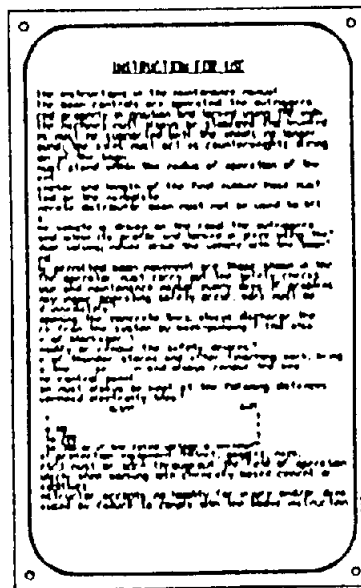

(P)

15

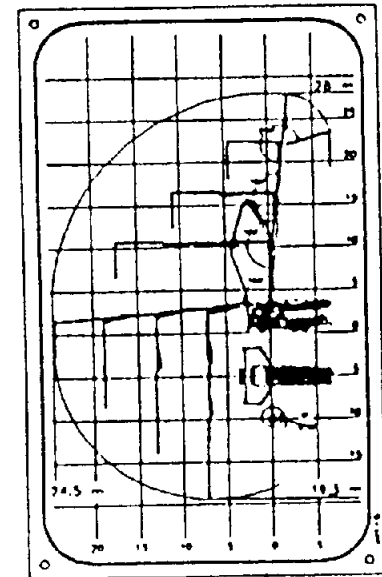

(N)

14

## DECAL ASSEMBLY

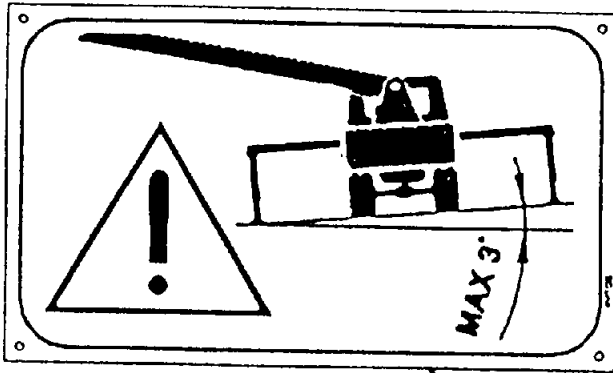

(S)

18

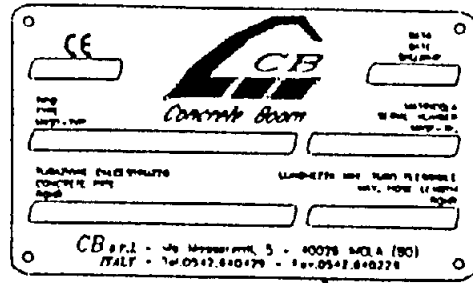

(T)

19

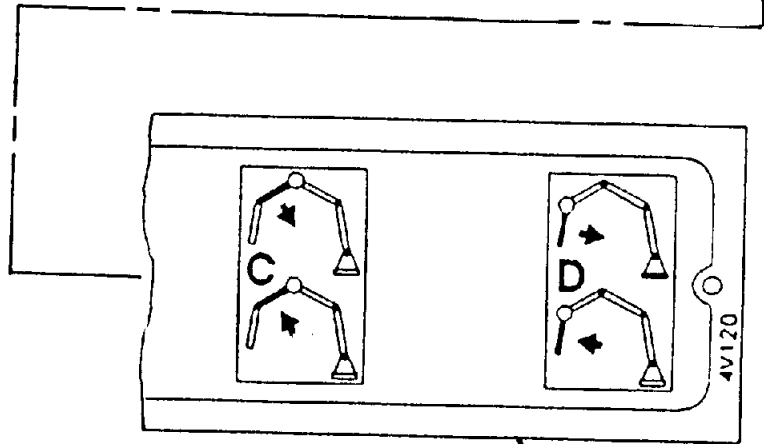
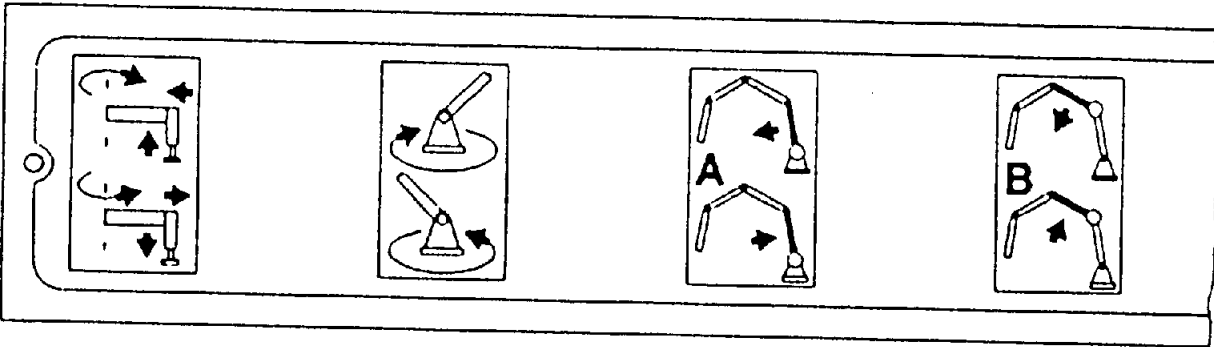

(U)

20

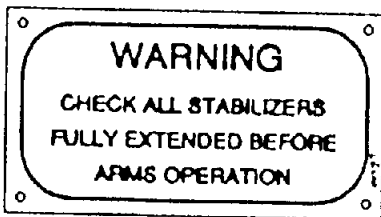

(V)

21

## DECAL ASSEMBLY

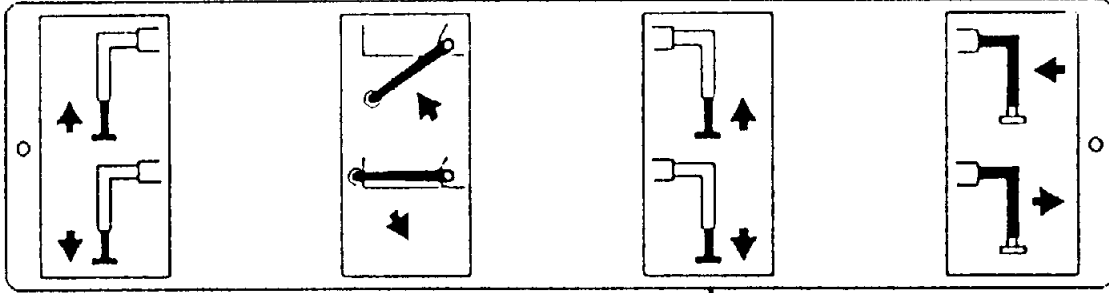

W

22



27

AB

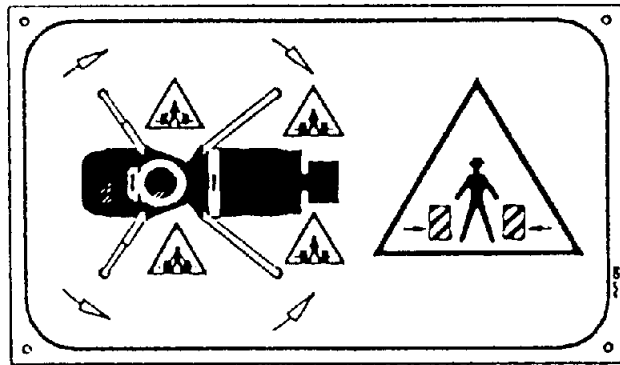

X

23

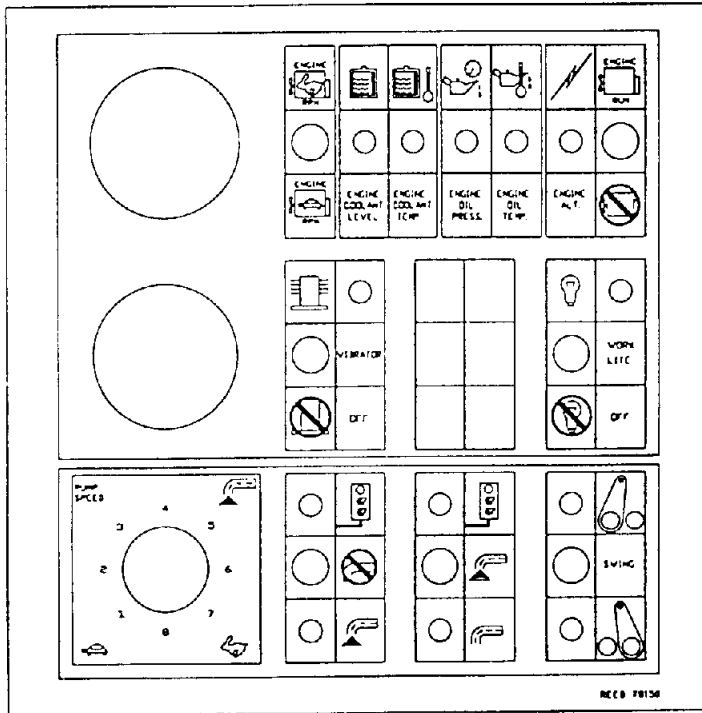

AA

26



Y

24

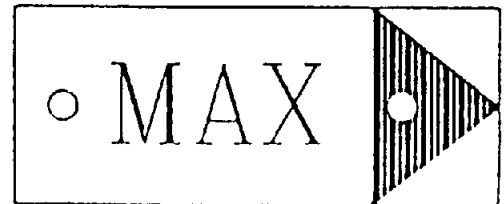

Z

25

MISCELLANEOUS DECALS

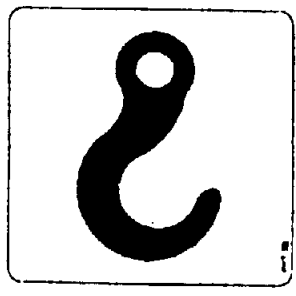

DECAL, LIFTING  
POINT ADHESIVE

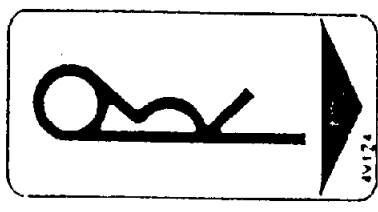

DECAL, SAFETY  
SPLIT PIN

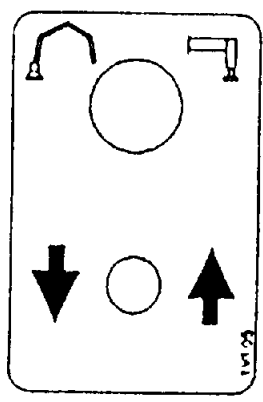

DECAL, ELECTRIC  
SWITCH LEVER

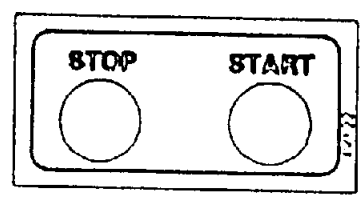

DECAL, BOOM CLOSED  
PILOT LIGHT

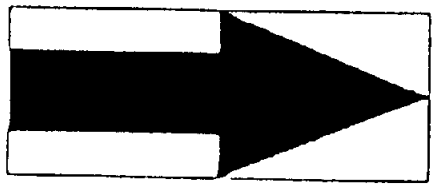

DECAL, ADHESIVE  
GREEN ARROW

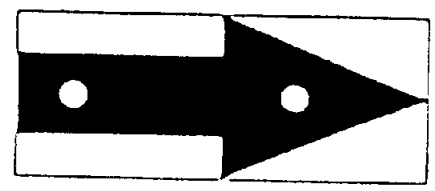

PLATE, ALUMINUM  
GREEN ARROW

**REED**CONCRETE PLACING  
EQUIPMENT**DECAL ASSEMBLY****PARTS**  
GROUP 10  
FIGURE 02  
PAGE 08

ITEM NO.	REED'S PARTS NO.	DESCRIPTION					QTY
		1	2	3	4	5	
-1	10-02	Assembly, Decal (See Group 10, Figure 01 for NHA)					Ref
2	C-4V112	• Plate, Maximum Stabilizers Loads					4
3	C-3V101	• Plate, Right Side Stabilizers					1
4	C-4V115	• Decal, C Letter Adhesive					1
5	C-4v121	• Plate, Electric Switch Lever					2
6	C-4V110	• Plate, Maximum Hose Length					1
7	C-4V116	• Decal, D Letter Adhesive					1
8	C-4V114	• Decal, B Letter Adhesive					1
9	C-4V106	• Plate, Never Use As Crane					1
10	C-4V107	• Plate, Danger Of Falling Object					1
11	C-4V105	• Plate, Death Hazard					1
12	C-4V113	• Decal, A Letter Adhesive					1
13	C-4V199	• Plate, Machine Identification Data					1
14	C-3V119	• Plate, Operate Field					1
15	C-4V118	• Plate, Instruction For Use					1
16	C-4V123	• Plate, Greaser					1
17	C-4V111	• Plate, Danger Of Crushing					1
18	C-4V108	• Plate, Maximum Inclination					1
19	C-4V198	• Plate, Chassis Identification Data					1
20	C-4V120	• Plate, Hydraulic Distributor					1
21	C-4V127-4V128	• Plate, Warning Stabilizers					1
22	C-3V102	• Plate, Left Side Stabilizers					1
23	C-4V109	• Plate, Danger Of Crushing					1
24	C-4V126	• Plate, Minimum Lever					1
25	C-4V125	• Plate, Maximum Lever					1
26	78550	• Decal, Control Box Panel					1
27		• Plate, Danger Oversize, Safety Drive					1

DASH (-) ITEM NOT ILLUSTRATED

REVISION:

**REED**

CONCRETE PLACING  
EQUIPMENT

**PARTS MANUAL**

**PARTS**  
GROUP 10  
FIGURE 03  
PAGE 01

THIS PAGE INTENTIONALLY LEFT BLANK.

**GROUP 20 HOPPER INSTALLATION CONTAINS THE FOLLOWING FIGURES:**

<b>FIGURE 00</b>	<b>TABLE OF CONTENTS</b>
<b>FIGURE 01</b>	<b>HOPPER INSTALLATION</b>
<b>FIGURE 02</b>	<b>REMIXER/WASH CONTROL VALVE ASSEMBLY</b>
<b>FIGURE 03</b>	<b>AGITATOR ASSEMBLY</b>
<b>FIGURE 04</b>	<b>AGITATOR DRIVE MOTOR ASSEMBLY</b>
<b>FIGURE 05</b>	<b>GATE ELBOW ASSEMBLY</b>

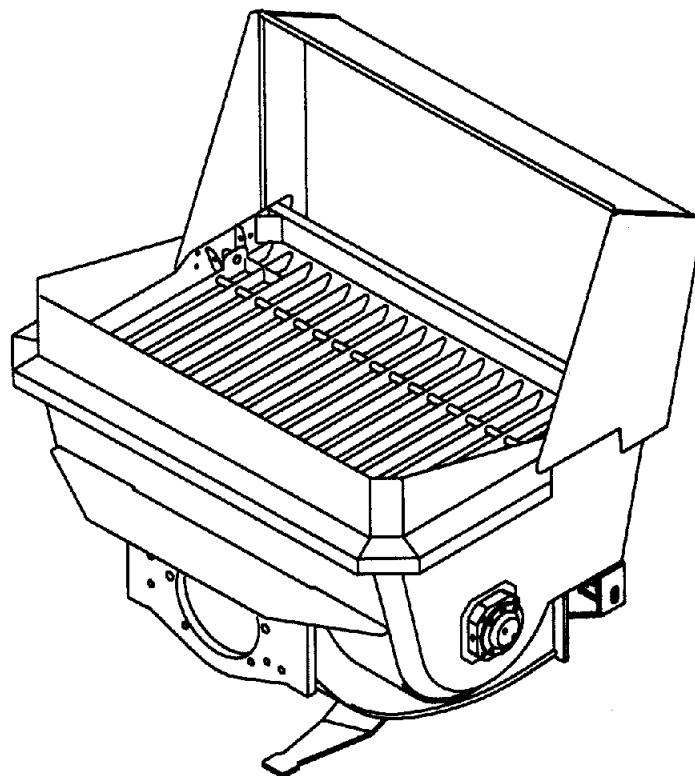

**REED**

CONCRETE PLACING  
EQUIPMENT

# HOPPER INSTALLATION

**PARTS**

GROUP 20

FIGURE 01

PAGE 01

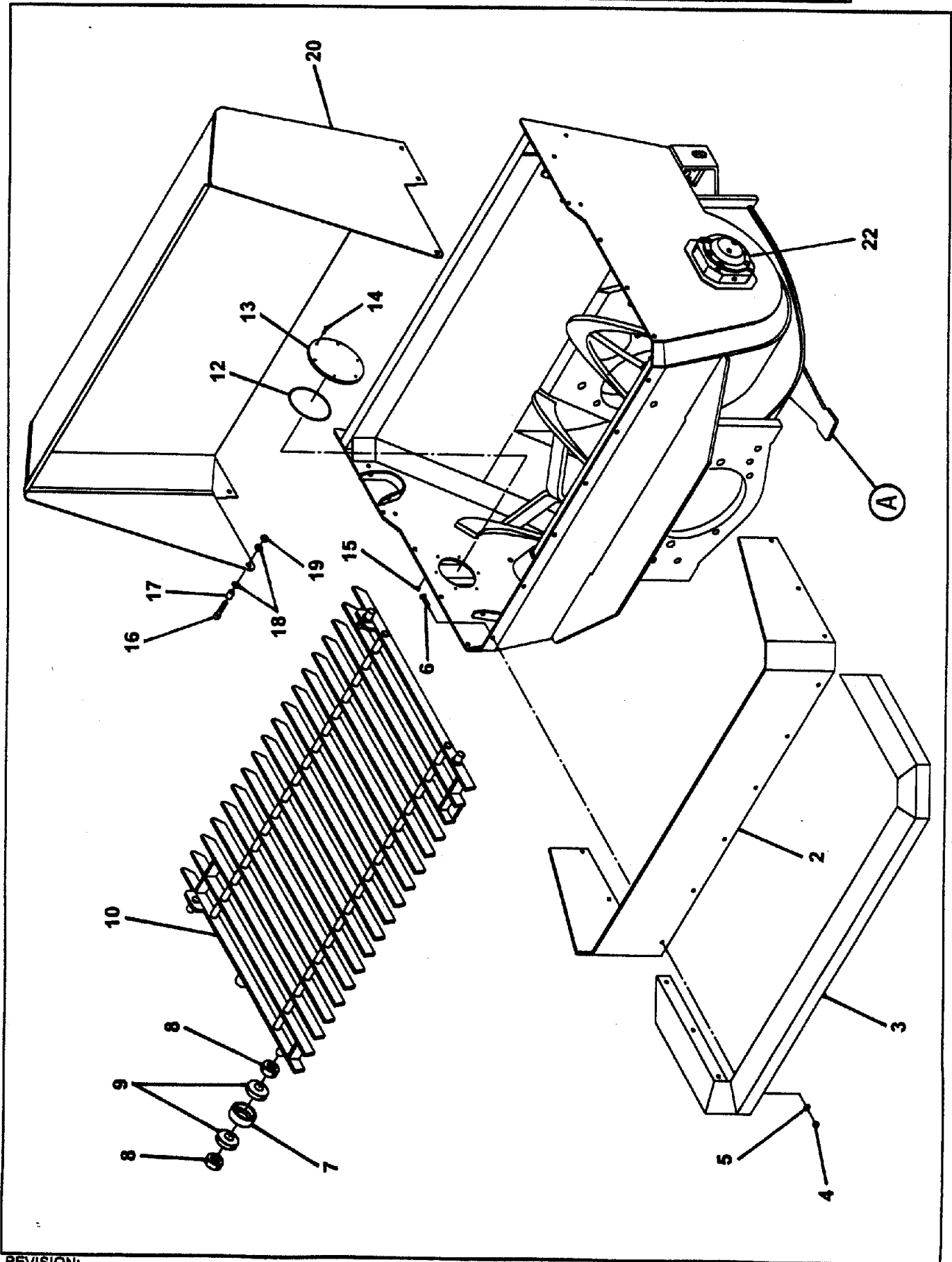

REVISION:



**REED**CONCRETE PLACING  
EQUIPMENT**HOPPER INSTALLATION****PARTS  
GROUP 20  
FIGURE 01  
PAGE 02**

ITEM NO.	REED'S PARTS NO.	DESCRIPTION					QTY
		1	2	3	4	5	
-1	20-01	Installation, Hopper (See Group 10, Figure 01 for NHA)					Ref
2	B-202007	• Guard, Rubber					1
3	B-224014	×	• Holder, Rubber Guard <i>OBS</i>				1
4	W-101848	• Nut, Cap M6 (attaching parts)					A/R
5	W-101627	• Washer (attaching parts)					A/R
6	W-103579	• Screw, Flat M6 x 25 (attaching parts)					A/R
7	W101849	• Buffer, Rubber					1
8	W-101559	• Washer					8
9	B-223011	<	• Nut, Cap				8
10	B-223003	• Grid					1
-11	W-100765	• Sensor					1
12		• O-Ring					1
13	B-223014	×	• Plate, Polyamid				1
14	W-103389	• Screw, M5 x 20 (attaching parts)					3
15		• Nut, Lock (attaching parts)					3
16	W-102214	• Bolt, Hex M10 x 20					4
17	W-100000	• Buffer, Rubber					4
18	W-102070	• Washer, Spring					8
19		• Nut					4
20	B-202004	×	• Board, Splash <i>HINGE ONE P/W 800394</i>				1
-21	W-100124	• Assembly, Agitator/Wash Control Valve (See Group 20, Figure 02 for DET)					1
22	B-254000	• Assembly, Agitator (See Group 20, Figure 03 for DET)					1

DASH (-) ITEM NOT ILLUSTRATED

REVISION:

# HOPPER INSTALLATION

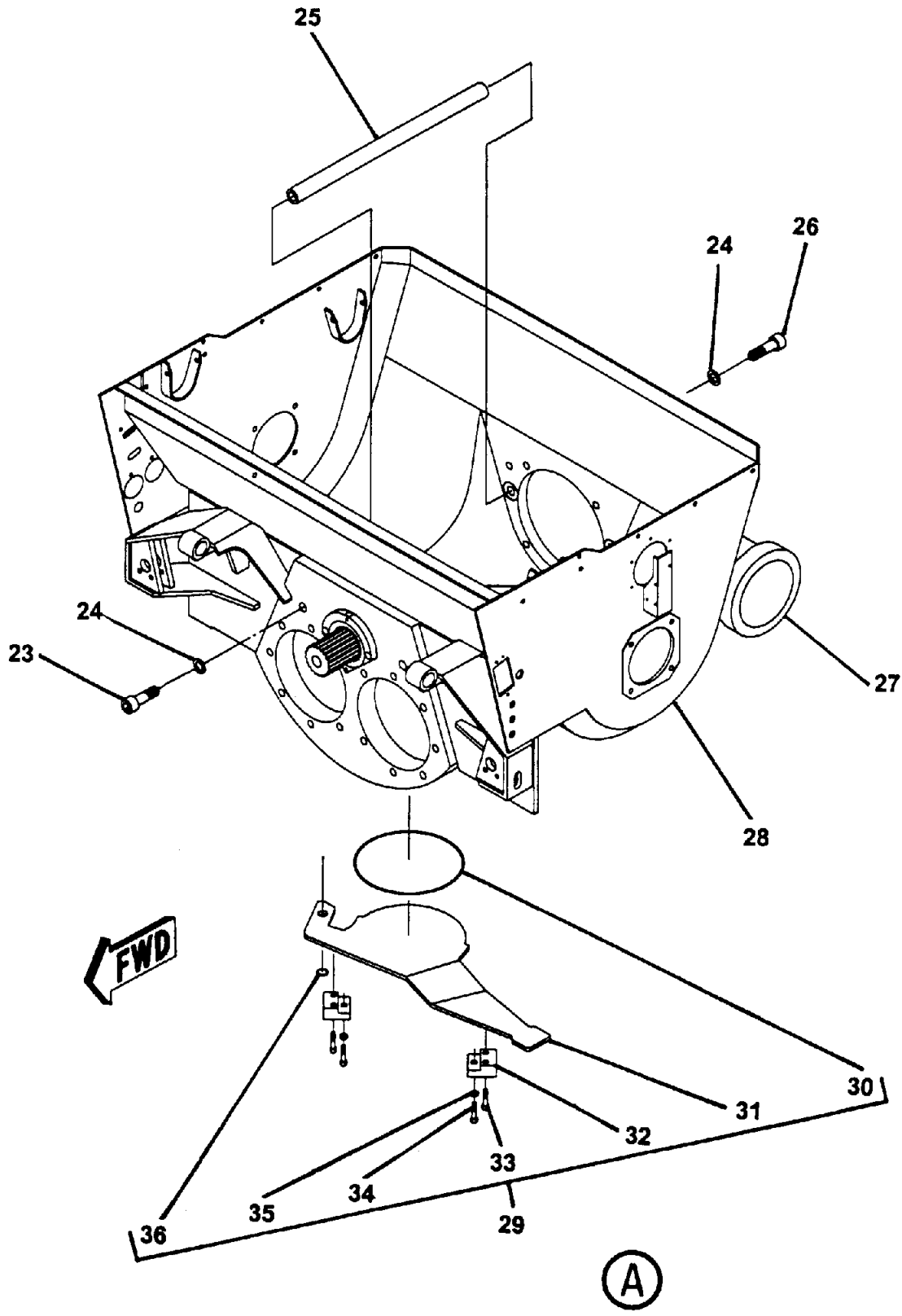



# HOPPER INSTALLATION

**PARTS**  
**GROUP 20**  
**FIGURE 01**  
**PAGE 04**

ITEM NO.	REED'S PARTS NO.	DESCRIPTION	QTY
		1 2 3 4 5	
23	W-103074	• Screw, Hex M24 x 120	2
24	W-102331	• Washer	4
25	B-174075 ✓	• Rod, Tie	2
26	W-103073	• Screw, Hex M24 x 95	2
27	B-193000 ✓	• Assembly, Gate Elbow (See Group 20, Figure 05 for DET)	1
28	B-173021 ✓	• Weldment, Hopper	1
29	B-173085 ✓	• Assembly, Cleaning Cover	1
30 x	W-102908	• • O-Ring, Round Cord 12 x 780 mm <i>(= 2.6' (size 3'))</i>	1
31	B-172130 ×	• • Cover, Cleaning	1
32	B-172126 ×	• • Block, Clamping	2
33	W-102855	• • Screw, M20 x 40 (attaching parts)	4
34	B-172218 ×	• • Screw, M20 x 50 (attaching parts)	2
35	W-102891	• • Nut, Hex M20 (attaching parts)	2
36	W-102864	• • Ring, Lock	1
-37	71429	• Assembly, Hopper Vibration (See Group 80, Figure 01 for DET)	1

DASH (-) ITEM NOT ILLUSTRATED

REVISION:

**AGITATOR /WASH  
CONTROL VALVE ASSEMBLY**

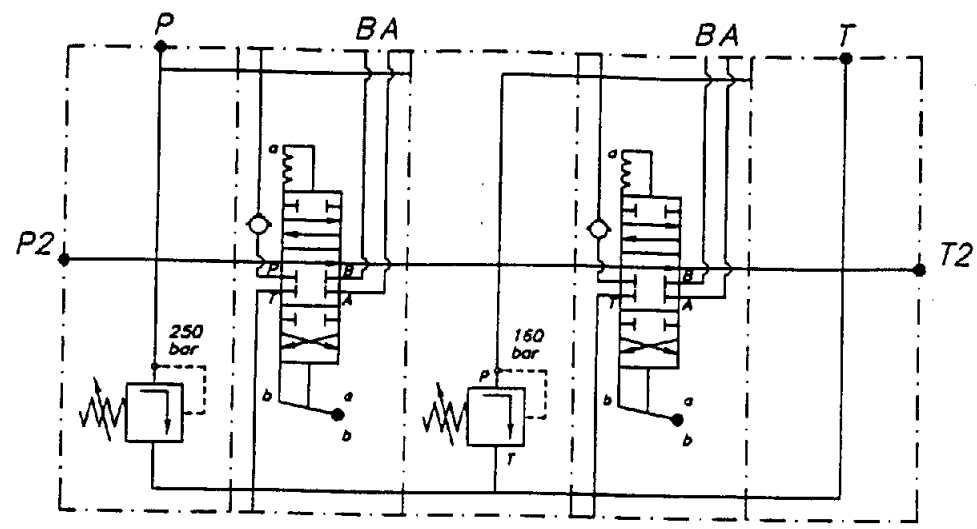
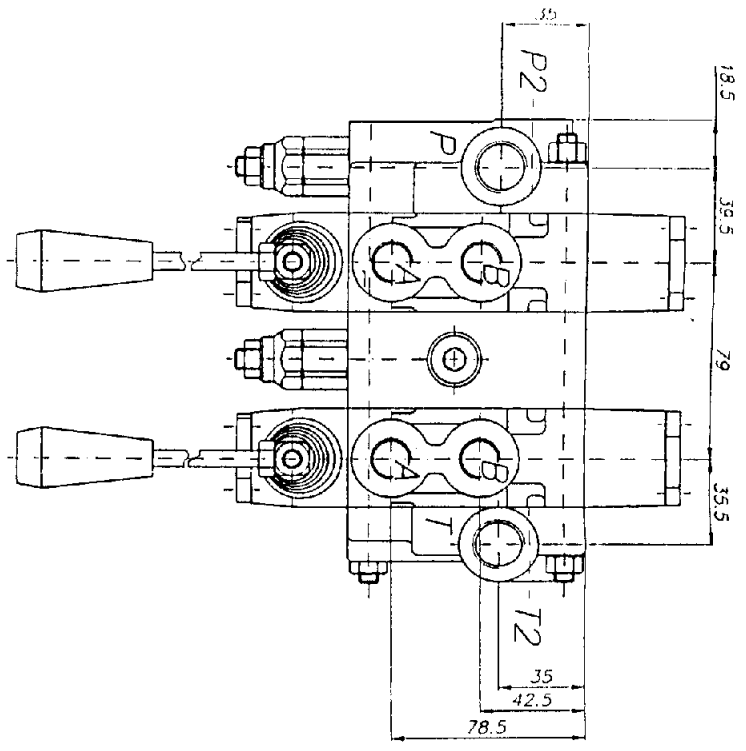
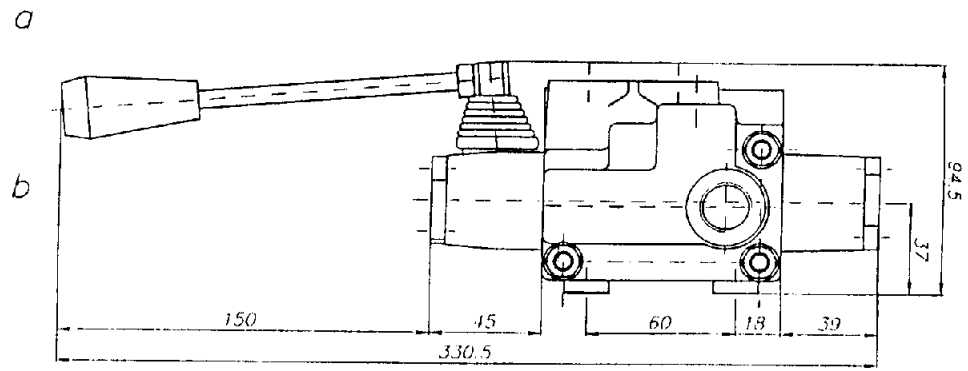



# AGITATOR AND WASH CONTROL VALVE ASSEMBLY

**PARTS**  
GROUP 20  
FIGURE 02  
PAGE 02

ITEM NO.	REED'S PARTS NO.	DESCRIPTION					QTY
		1	2	3	4	5	
-1	W-100124	Assembly, Agitator and Wash Control Valve (See Group 20, Figure 01 for NHA)					Ref
2	W-102747	• Lever, Control Valve					2
3	W-105559	• Cartridge, Control Valve					2
4	W-105644	• Element					2
5	W-101881	• Kit, seal					4

DASH (-) ITEM NOT ILLUSTRATED

# AGITATOR ASSEMBLY

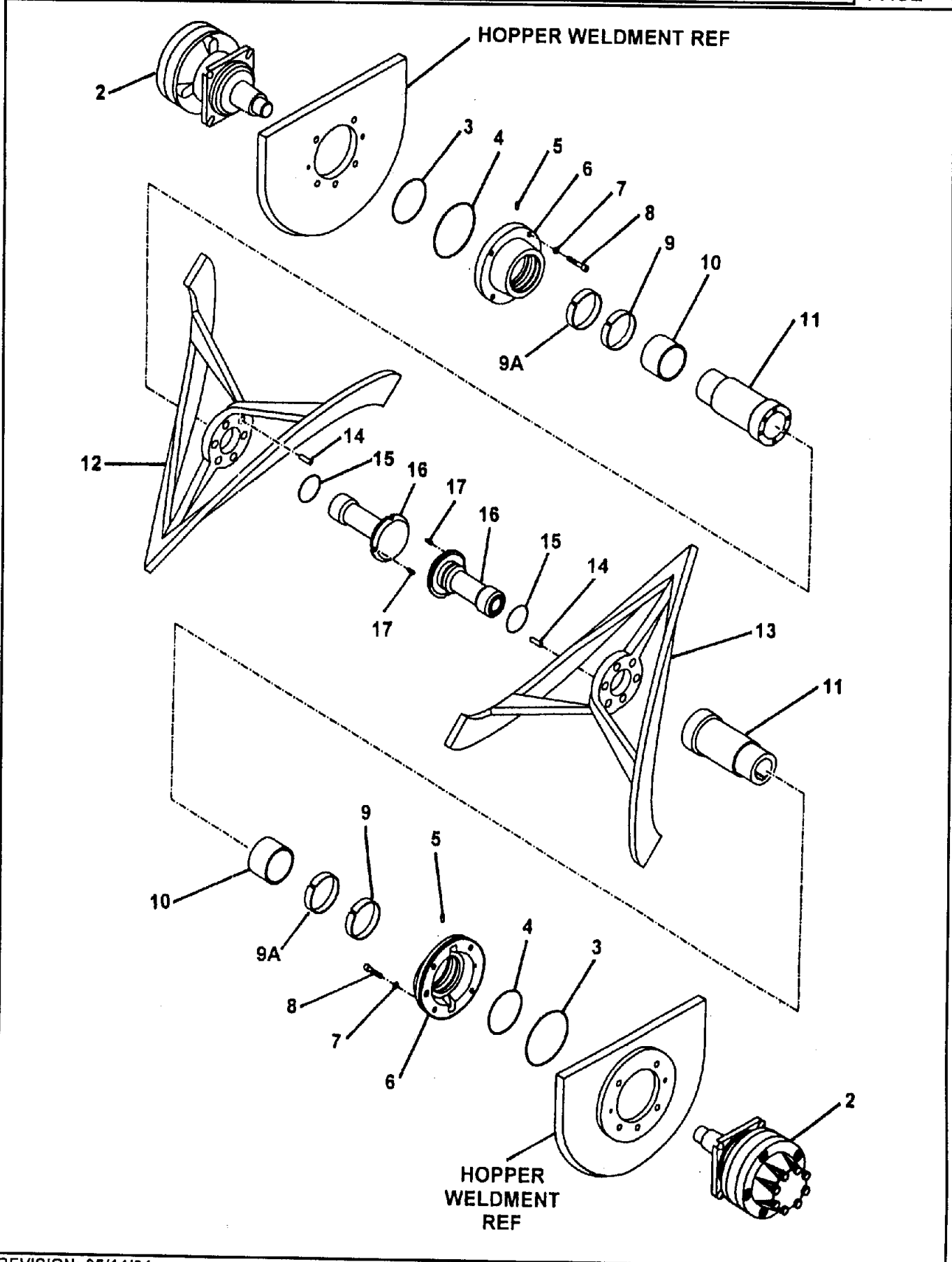

**AGITATOR ASSEMBLY**

ITEM NO.	REED'S PARTS NO.	DESCRIPTION					QTY
		1	2	3	4	5	
-1	B-254000	Assembly, Agitator (See Group 20, Figure 01 for NHA)					Ref
2	W-101240	• Assembly, Agitator Drive Motor (See Group 20, Figure 04 for DET)					1
3	W-103064	• O-Ring					2
4	W-103063	• O-Ring					2
5	W-100499	• Screw, M5 Set					2
6	B-254101	• Assembly, Flange					2
7	W-102962	• Washer					8
8	W-103062	• Screw, M12 Hex					8
9	W-102544	• Ring, Groove-Outer					2
9A	B-253029	• Ring, Groove-Inner					2
10	B-254104	• Sleeve, Wear					2
11	B-254102	• Shaft					2
12	B-254121	• Agitator, Left					1
13	B-254122	• Agitator, Right					1
14	W-103065	• Pin 10m					12
15	W-103249	• O-Ring					2
16	B-254103	• Nut					2
17	W-103106	• Sleeve, Clamping					4

*FIRST TEN UNITS*

*W-101241 Seal kit*

DASH (-) ITEM NOT ILLUSTRATED

*80 100 125*

# AGITATOR DRIVE MOTOR ASSEMBLY

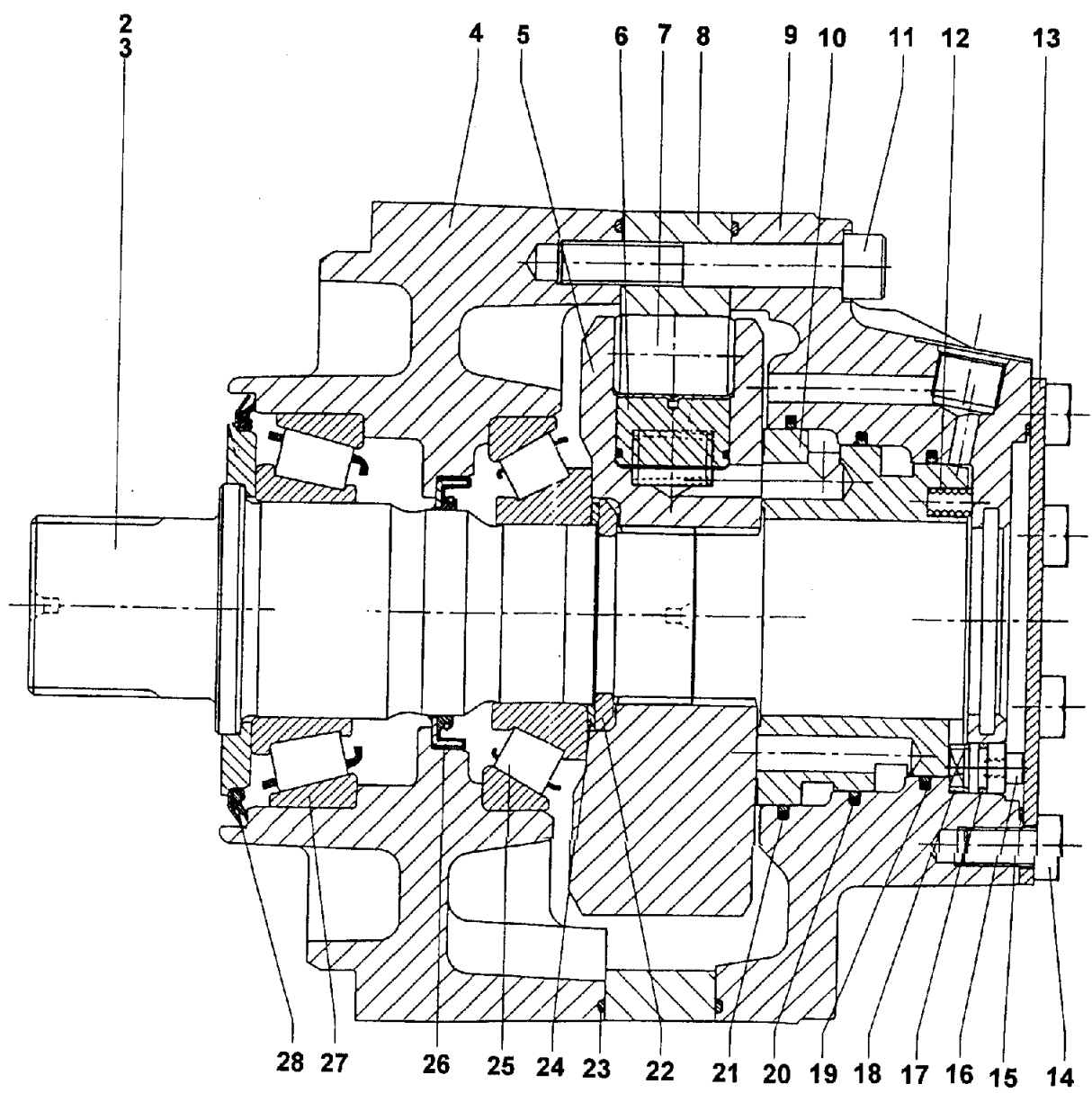

REVISION:



**REED**CONCRETE PLACING  
EQUIPMENT**AGITATOR DRIVE MOTOR ASSEMBLY****PARTS**

GROUP 20

FIGURE 04

PAGE 02

ITEM NO.	REED'S PARTS NO.	DESCRIPTION	QTY
		1 2 3 4 5	
-1	W-101240	Assembly, Agitator Drive Motor (See Group 20, Figure 03 for NHA)	Ref
2		• Assembly, Auger Drive Motor	1
3		• Shaft	1
4		• Case, Front	1
5		• Block, Cylinder	1
6		• Piston	8
7		• Roller	8
8		• Cam	1
9		• Case, Rear	1
10		• Ring, Distributor	1
11		• Screw, Cap M12 x 75	12
12		• Spring	6
13		• Plate, Cover	1
14		• Screw, Hex M10 x 20	8
15		• O-Ring	1
16		• Screw, Cap M5 x 6	1
17		• O-Ring	1
18		• Pin, Stop	1
19		• Seal, Rod	1
20		• Seal, Rod	1
21		• Seal, Rod	1
22		• Ring, Split	1
23		• O-Ring	2
24		• Washer	1
25	W-105716	• Bearing REAR	1
26		• Seal, Shaft	1
27	W-105715	• Bearing FRONT	1
28		• Seal, Face	1

DASH (-) ITEM NOT ILLUSTRATED

W-101241 SEAL KIT

REVISION:

**REED**

CONCRETE PLACING  
EQUIPMENT

# GATE ELBOW ASSEMBLY

**PARTS**

**GROUP 20**

**FIGURE 05**

**PAGE 01**

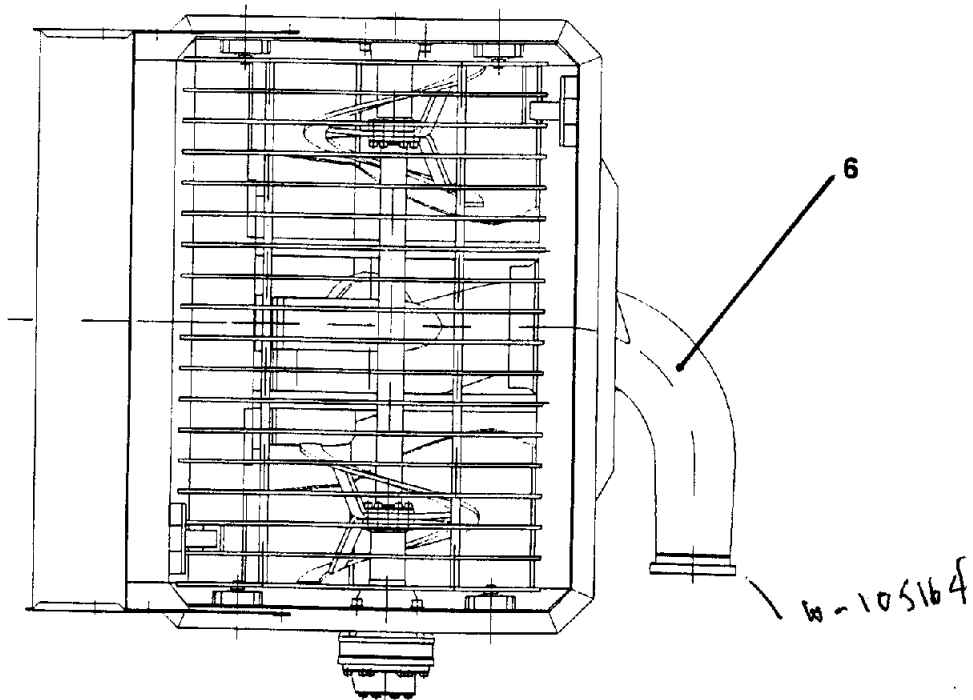
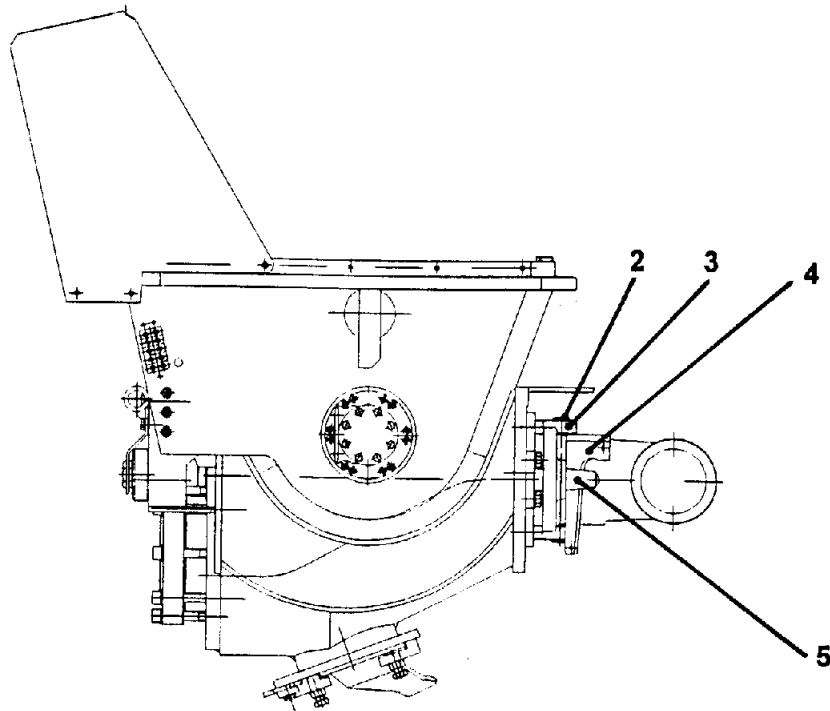

REVISION:



# GATE ELBOW ASSEMBLY

**PARTS**  
**GROUP 20**  
**FIGURE 05**  
**PAGE 02**

ITEM NO.	REED'S PARTS NO.	DESCRIPTION	QTY
		1 2 3 4 5	
-1	B-193000	Assembly, Gate Elbow (See Group 20, Figure 01 for NHA)	Ref
2	B-193014	• Pin <i>USE 194050</i>	1
3	B-193004	• Hinge	1
4	B-193008	• Wedge, Locking <i>USE 1940#5</i>	1
5	B-193010	• Pin, Locking	1
6	B-193002	• Elbow, Gate	1

*w-104025 O-Ring Hopper Elbow*      DASH (-) ITEM NOT ILLUSTRATED

*193010*

*w-105164 O-Ring Hopper outlet*

THIS PAGE INTENTIONALLY LEFT BLANK.

**GROUP 30 HYDRAULIC TANK INSTALLATION CONTAINS THE FOLLOWING FIGURES:**

<b>FIGURE 00</b>	<b>TABLE OF CONTENTS</b>
<b>FIGURE 01</b>	<b>TANK INSTALLATION</b>
<b>FIGURE 02</b>	<b>BOOM HYDRAULIC TANK AND AUXILIARY WATER TANK ASSEMBLY</b>
<b>FIGURE 03</b>	<b>PUMP HYDRAULIC TANK ASSEMBLY</b>
<b>FIGURE 04</b>	<b>WATER TANK ASSEMBLY</b>
<b>FIGURE 05</b>	<b>WATER PUMP MOTOR ASSEMBLY</b>
<b>FIGURE 06</b>	<b>WASH WATER PUMP ASSEMBLY</b>

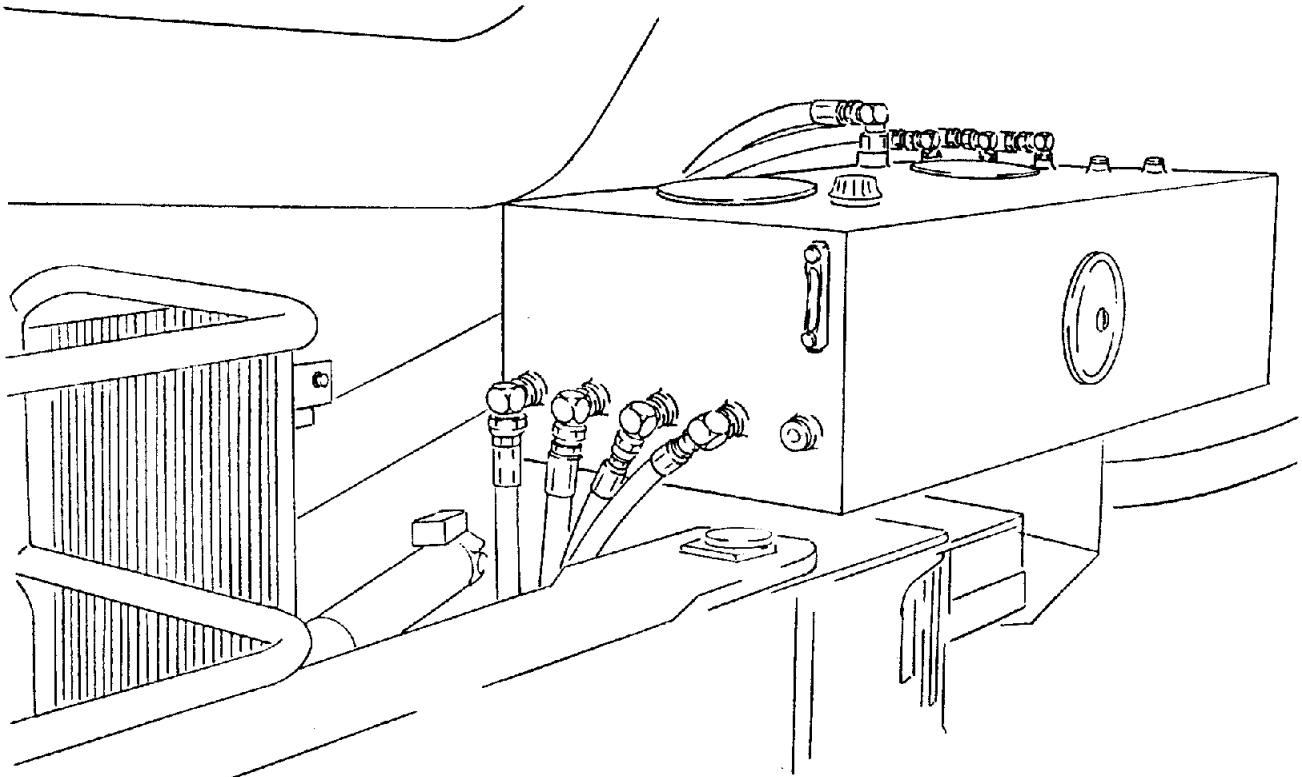

**REED**

CONCRETE PLACING  
EQUIPMENT

# TANK INSTALLATION

PARTS  
GROUP 30  
FIGURE 01  
PAGE 01

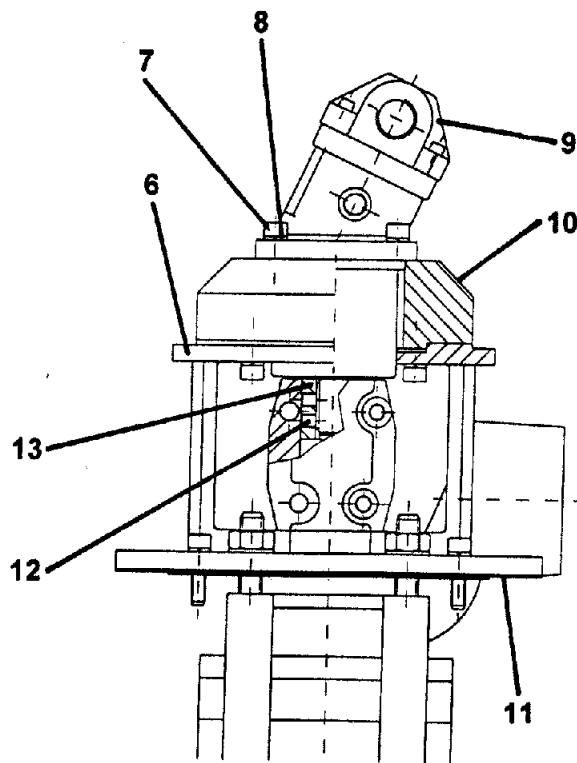
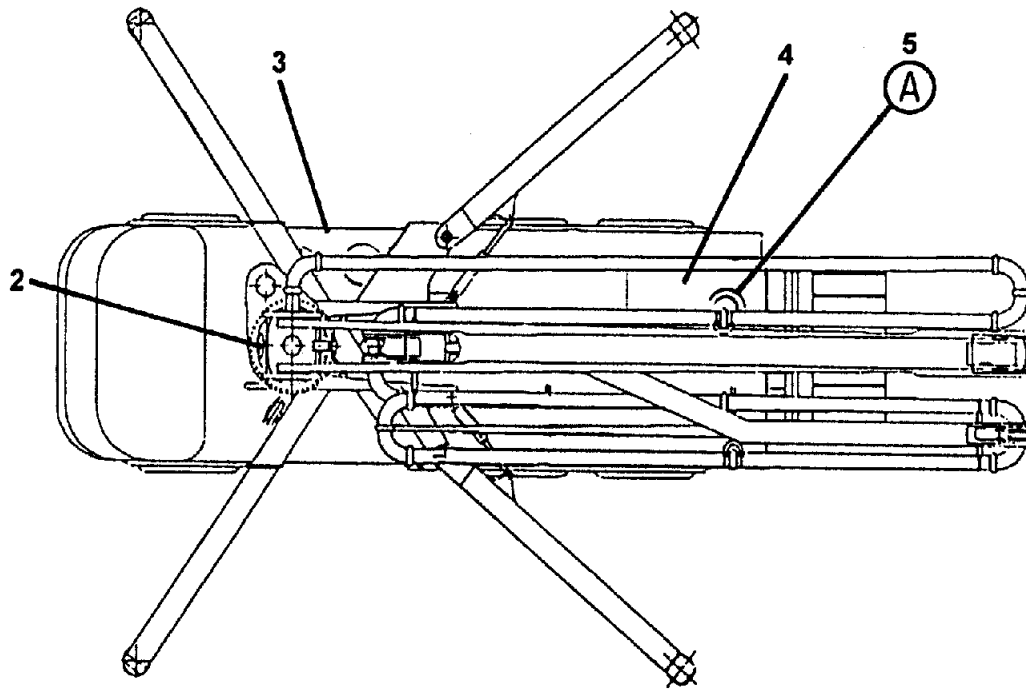

(A)

REVISION:

**TANK INSTALLATION**

ITEM NO.	REED'S PARTS NO.	DESCRIPTION	QTY
		1 2 3 4 5	
-1	30-01	Installation, Tank (See Group 10, Figure 01 for NHA)	Ref
2	30-02	• Assembly, Boom Hydraulic Tank And Auxiliary Water Tank (See Group 30, Figure 02 for DET)	1
3	30-03	• Assembly, Pump Hydraulic Tank (See Group 30, Figure 03 for DET)	1
4	B-314030	• Assembly, Water Tank (See Group 30, Figure 04 for DET)	1
5	B-323000	• Assembly, Water Pump And Drive	1
6	W-100122	• • Assembly, Water Pump Motor (See Group 30, Figure 05 for DET)	1
7	W-103673	• • Screw, M6 x 25	12
8	W-103674	• • Washer, SPL	12
9	W-100121	• • Assembly, Wash Water Pump (See Group 30, Figure 06 for DET)	1
10	B-321505	• • Flange	1
11	B-321506	• • Gasket	1
12	W-103646	• • Screw, M6 x 25	2
13	B-321502	• • Coupling	1

DASH (-) ITEM NOT ILLUSTRATED

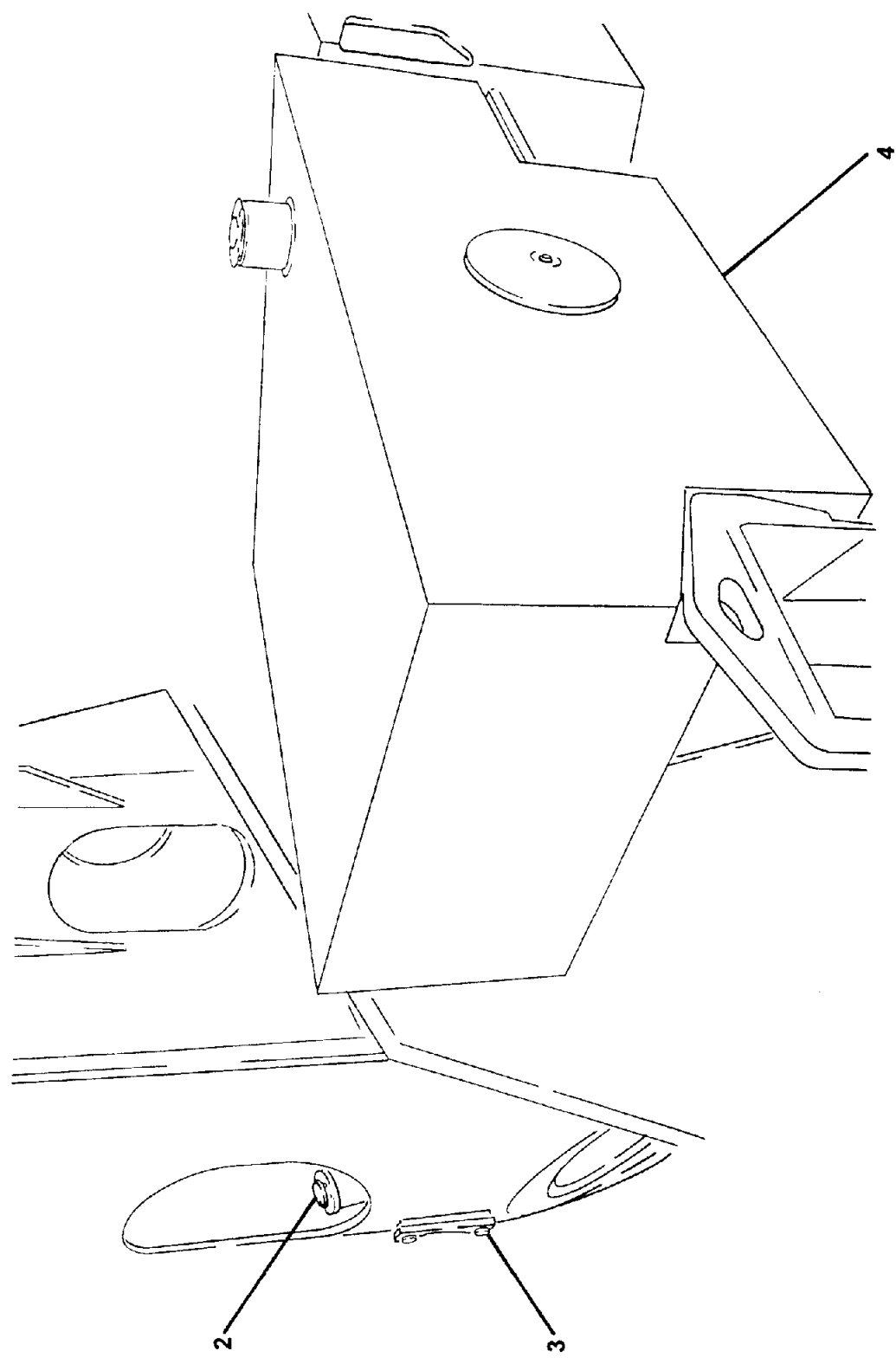

REVISION:



**REED**CONCRETE PLACING  
EQUIPMENT**BOOM HYDRAULIC TANK AND  
AUXILIARY WATER TANK INSTALLATION****PARTS  
GROUP 30  
FIGURE 02  
PAGE 02**

ITEM NO.	REED'S PARTS NO.	DESCRIPTION	QTY
		1 2 3 4 5	
-1	30-02	Installation, Boom Hydraulic Tank and Auxiliary Water Tank (See Group 30, Figure 01 for NHA)	Ref
2		• Assembly, Boom Hydraulic Tank	1
3	74509	• • Gauge, Sight	1
4		• Assembly, Auxiliary Tank	1

DASH (-) ITEM NOT ILLUSTRATED

REVISION:

# PUMP HYDRAULIC TANK ASSEMBLY

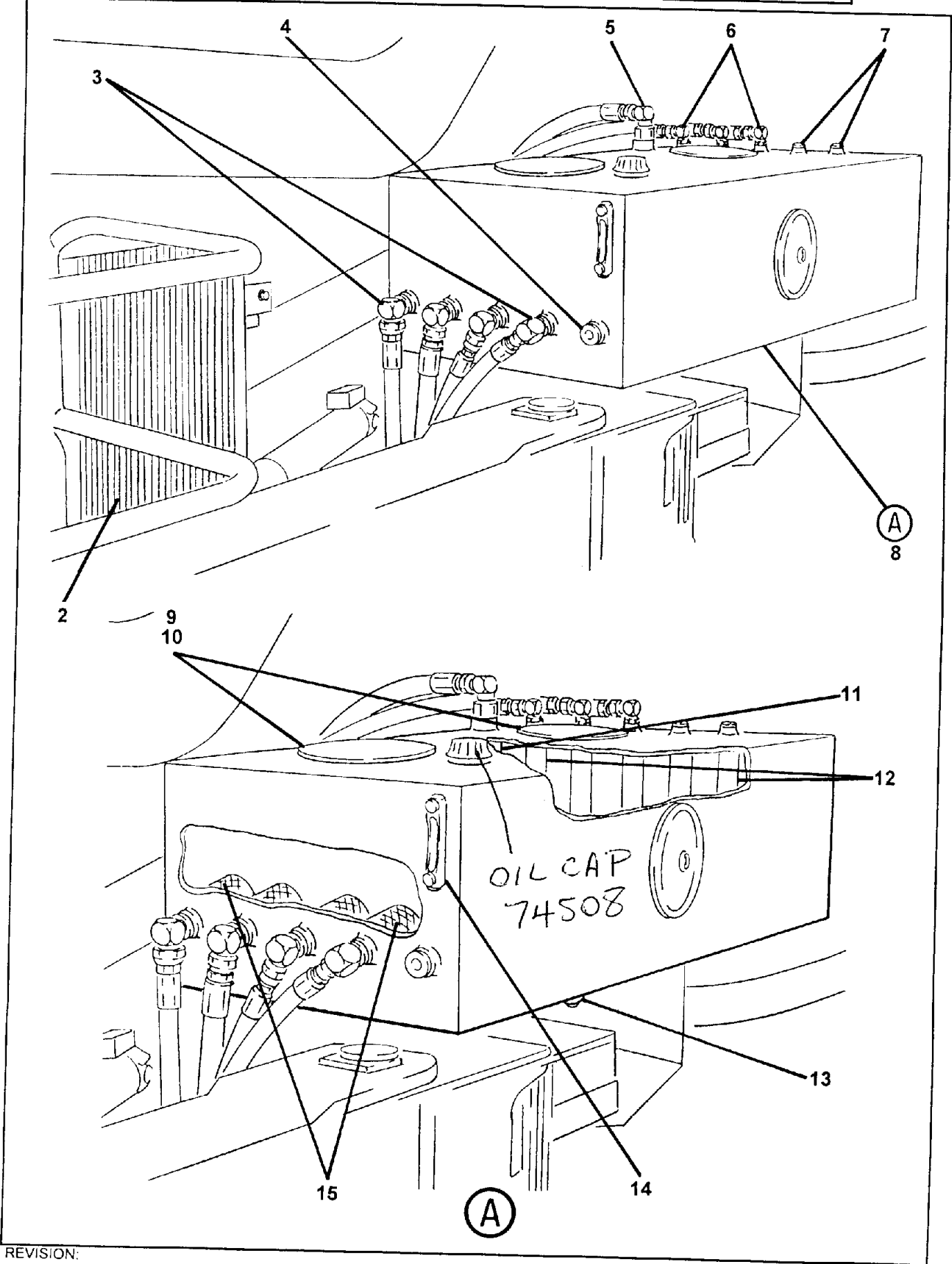

**REED**CONCRETE PLACING  
EQUIPMENT**PUMP HYDRAULIC TANK ASSEMBLY****PARTS**

GROUP 30

FIGURE 03

PAGE 02

ITEM NO.	REED'S PARTS NO.	DESCRIPTION					QTY
		1	2	3	4	5	
-1	30 - 03	Assembly, Pump Hydraulic Tank (See Group 30, Figure 01 for NHA)					Ref
2	800051	• Assembly, Hydraulic Cooler					1
3		• Elbow, 90 FS6801 - 16 - 16					4
4		• Plug					1
5		• Elbow, 90 FS6801 - 24 - 24					1
6		• Elbow, 90 FS6801 - 20 - 20					3
7		• Plug					2
8	800010	• Assembly, Hydraulic Tank					1
9	800013	• • Cover, Hydraulic Tank					2
10	72990	• • Ring					2
11	800011	• • Pipe, Return					1
12	800012	• • Pipe, Return					5
13	73557	• • Sump					1
14	74509	• • Gauge, Sight					1
15	79247	• • Strainer					4

DASH (-) ITEM NOT ILLUSTRATED

REVISION:

# WATER TANK ASSEMBLY

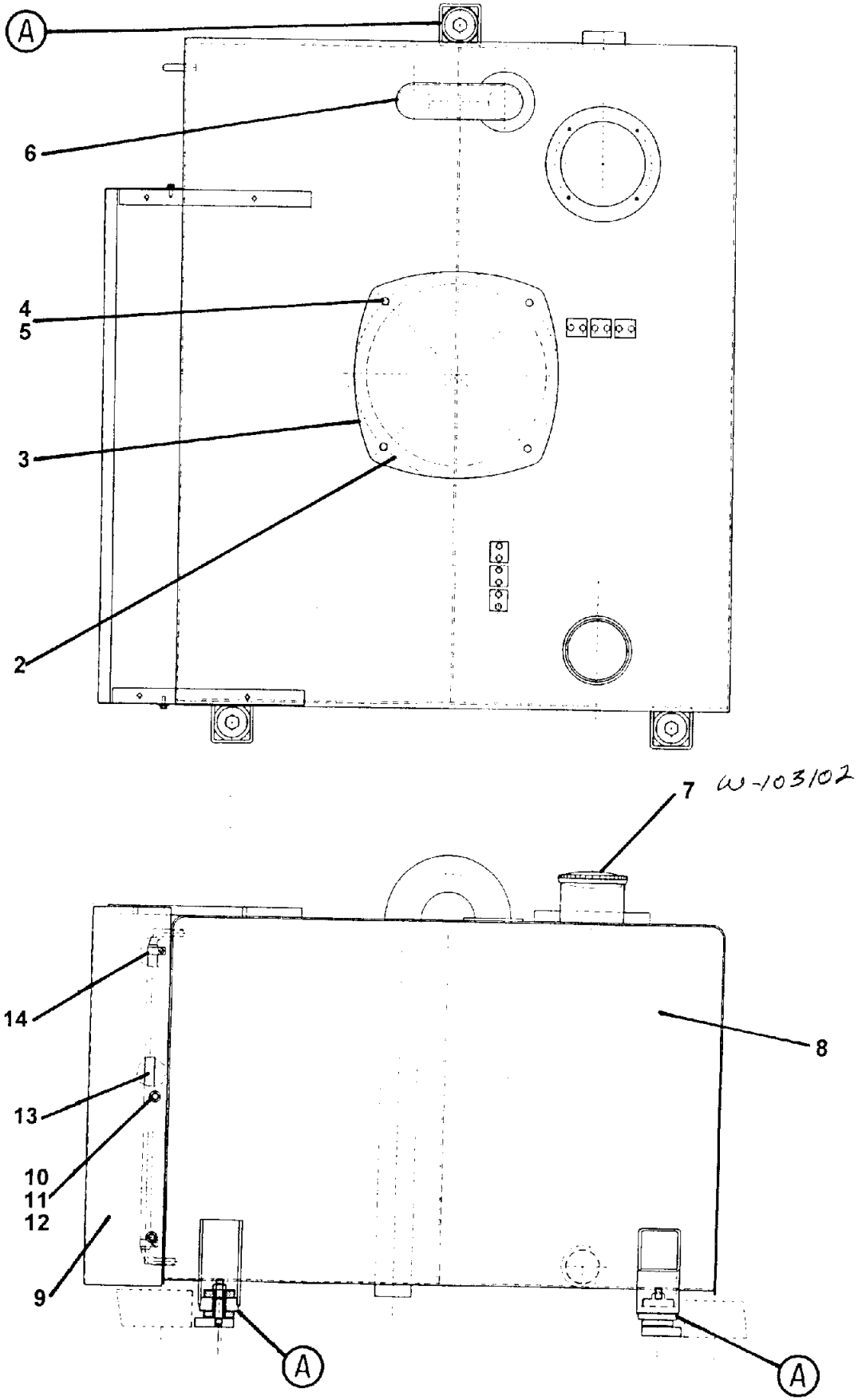

REVISION:

**WATER TANK ASSEMBLY**

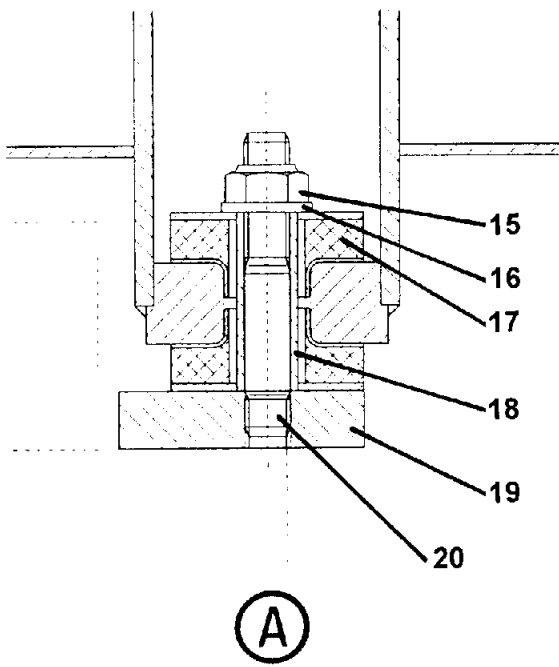

ITEM NO.	REED'S PARTS NO.	DESCRIPTION	QTY
		1 2 3 4 5	
-1	B-314030	Assembly, Water Tank (See Group 30, Figure 01 for NHA)	Ref
2	B-314004	• Cover, Rubber	1
3	B-314003	• Cover	1
4	W-101010	• Nut, M12 (attaching parts)	4
5	W-102896	• Washer, SPL Lock (attaching parts)	4
6	B-314021	• Pipe	1
7	W-103102	• Cap, Bayonet Lock	1
8	B-314031	• Weldment, Water Tank	1
9	B-314035	• Cover	1
10	W-102879	• Screw, Hex M6 x 16 (attaching parts)	6
11	W-103000	• Washer, SPL Lock (attaching parts)	6
12	W-103572	• Washer (attaching parts)	6
13	W-103104	• Hose, Fuel 0.5 m	1
14	W-103103	• Clamp, Hose	1
15	W-102121	• Nut, Lock	3
16	W-100504	• Washer	3
17	W-102490	• Buffer, Rubber	3
18	B-404066	• Pipe	3
19	B-314002	• Plate	3
20	W-103177	• Stud, M12 x 80	3

DASH (-) ITEM NOT ILLUSTRATED

# WASH WATER PUMP ASSEMBLY

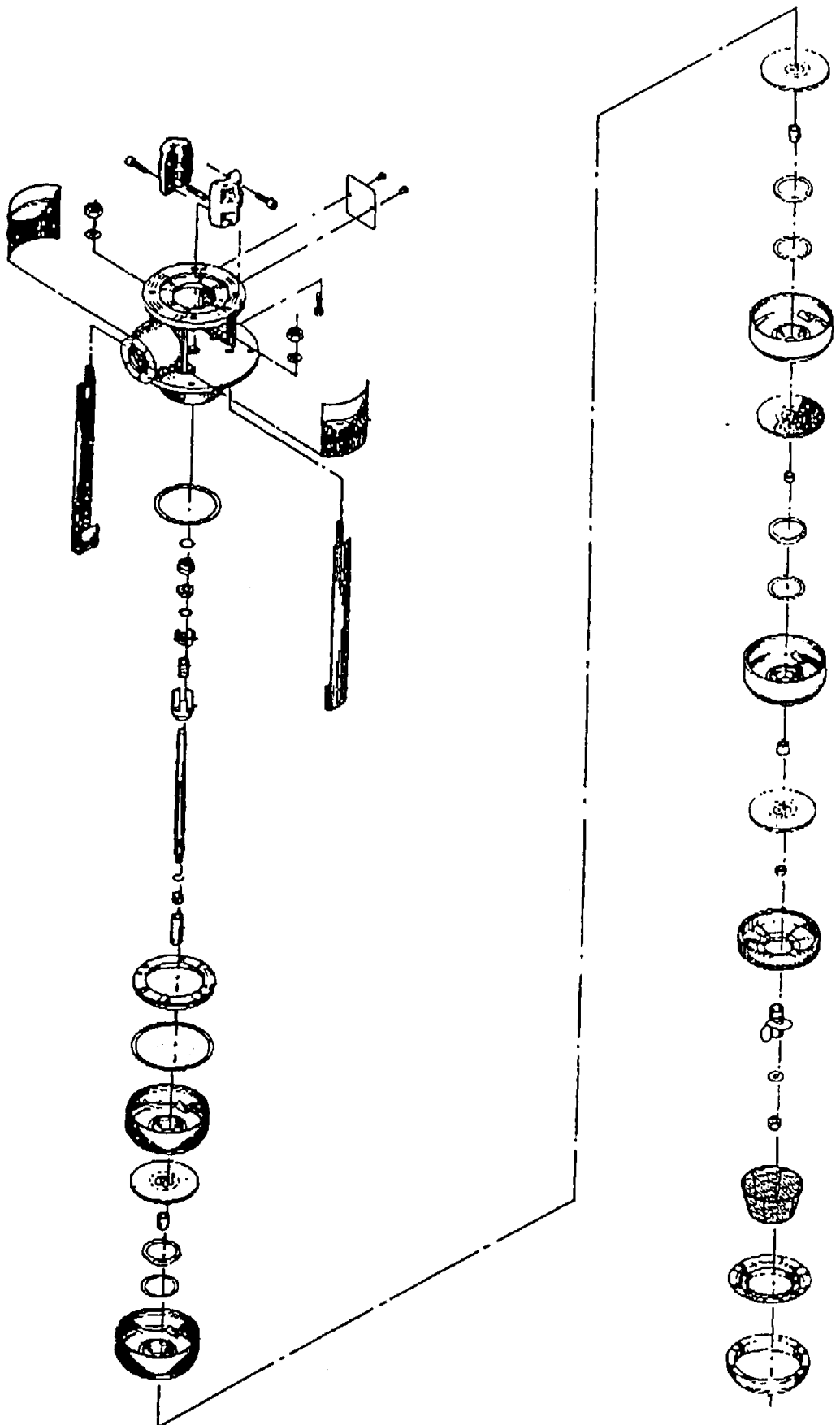

REVISION:

**REED**

CONCRETE PLACING  
EQUIPMENT

**WASH WATER PUMP ASSEMBLY**

**PARTS**

**GROUP 30**

**FIGURE 05**

**PAGE 02**

THIS GROUP 30, FIGURE 05, PARTS NUMBER C- W100122,  
**WASH WATER PUMP ASSEMBLY,**  
DETAIL PARTS LIST IS NOT AVAILABLE THIS REVISION.

REVISION:

# WASH WATER PUMP ASSEMBLY

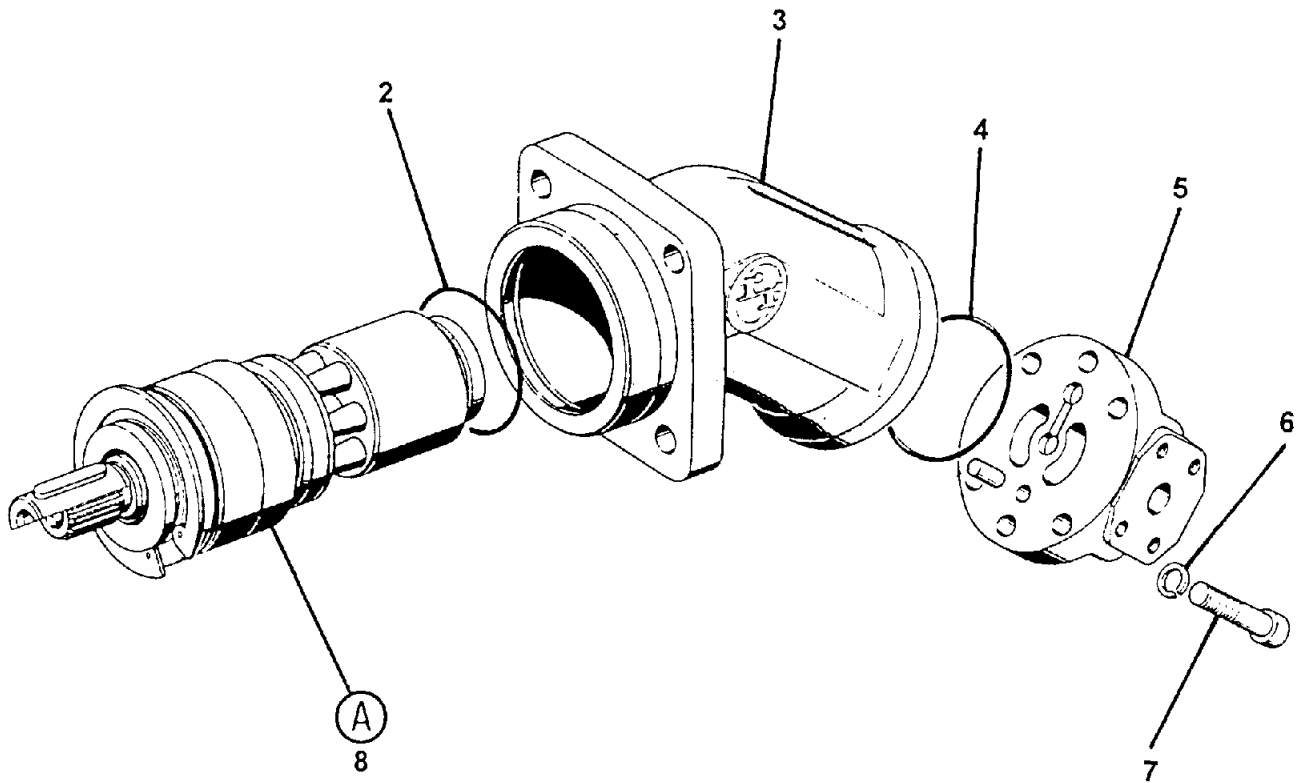



**REED**CONCRETE PLACING  
EQUIPMENT**WASH WATER PUMP ASSEMBLY****PARTS  
GROUP 30  
FIGURE 06  
PAGE 02**

ITEM NO.	REED'S PARTS NO.	DESCRIPTION					QTY
		1	2	3	4	5	
-1	W-100121	Assembly, Wash Water Pump (See Group 30, Figure 01 for NHA)					Ref
2		• O-Ring					1
3		• Housing					1
4		• O-Ring					1
5		• Plate, Port					1
6		• Washer, Lock					4
7		• Screw, M 6 x 16 - 8.8					4
8		• Sub-Assembly, Rotary					1
9		• • Ring Retaining					1
10		• • Cover					1
11		• • Ring, Shaft Seal					1
12		• • Ring Retaining					1
13		• • Bearing, Tapered Roller					1
14		• • Shim					2
15		• • Shim					2
16		• • Shim					2
17		• • Bearing, Angular Contact Ball					2
18		• • Key, Shaft 4 x 4					1
19		• • Shaft, Drive					1
20		• • Disc					1
21		• • Plate, Retaining					1
22		• • Rivet, 2.5 x 14					7
23		• • Pin, Center					1
24		• • Cup, Spring					4
25		• • Collar, Spring					1
26		• • Shim					1
27		• • Piston					7
28		• • Ring, Steel Sealing					7
29		• • Cylinder					1
30		• • Plate, Control					1
31		• • Pin					1

DASH (-) ITEM NOT ILLUSTRATED

REVISION:

**WASH WATER PUMP ASSEMBLY**

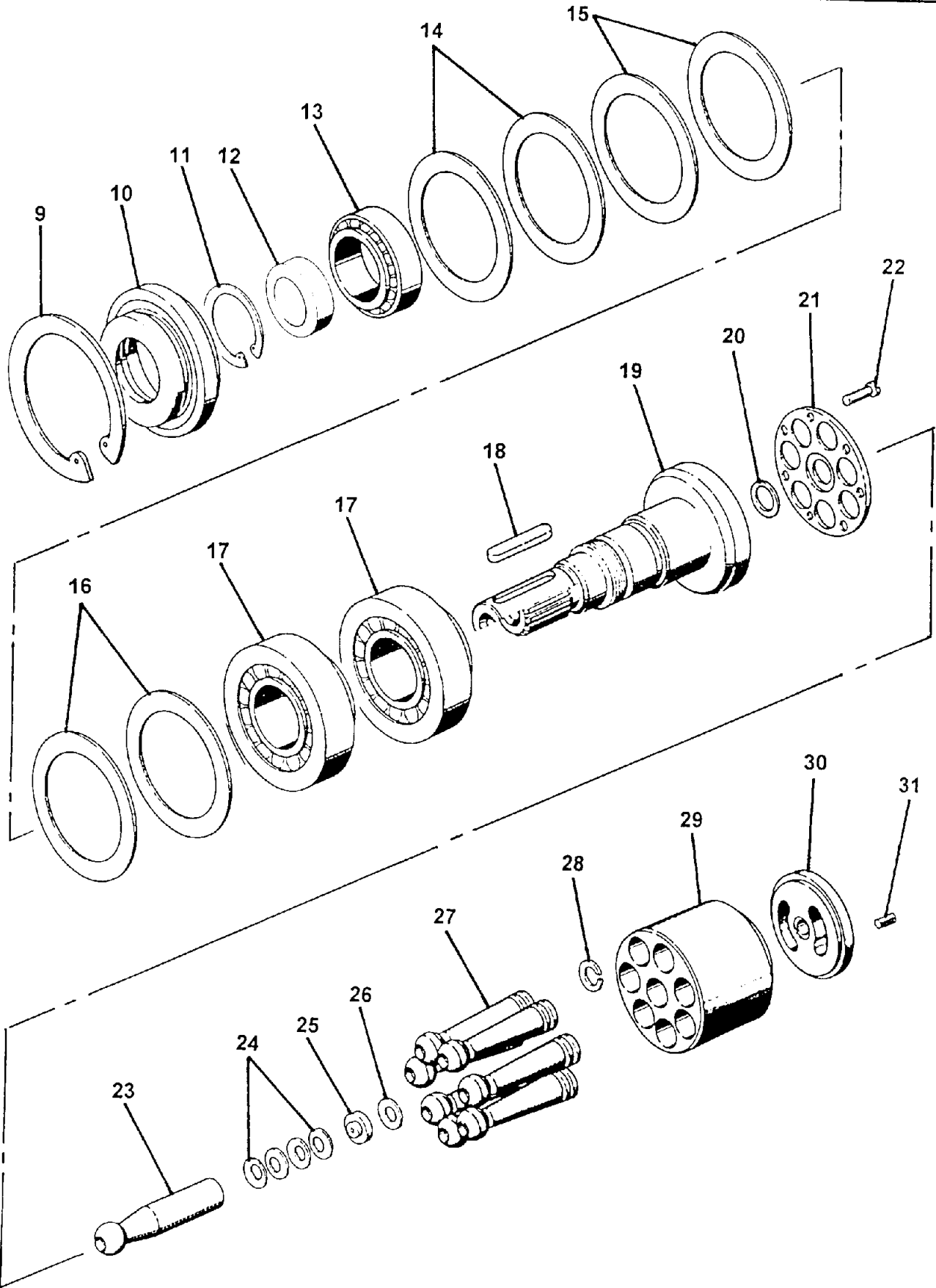

**WASH WATER PUMP ASSEMBLY**

ITEM NO.	REED'S PARTS NO.	DESCRIPTION	QTY
		1 2 3 4 5	
-1	W-100121	Assembly, Wash Water Pump (See Group 30, Figure 01 for NHA)	Ref
2		• O-Ring	1
3		• Housing	1
4		• O-Ring	1
5		• Plate, Port	1
6		• Washer, Lock	4
7		• Screw, M 6 x 16 - 8.8	4
8		• Sub-Assembly, Rotary	1
9		• • Ring Retaining	1
10		• • Cover	1
11		• • Ring, Shaft Seal	1
12		• • Ring Retaining	1
13		• • Bearing, Tapered Roller	1
14		• • Shim	2
15		• • Shim	2
16		• • Shim	2
17		• • Bearing, Angular Contact Ball	2
18		• • Key, Shaft 4 x 4	1
19		• • Shaft, Drive	1
20		• • Disc	1
21		• • Plate, Retaining	1
22		• • Rivet, 2.5 x 14	7
23		• • Pin, Center	1
24		• • Cup, Spring	4
25		• • Collar, Spring	1
26		• • Shim	1
27		• • Piston	7
28		• • Ring, Steel Sealing	7
29		• • Cylinder	1
30		• • Plate, Control	1
31		• • Pin	1

DASH (-) ITEM NOT ILLUSTRATED

**REED**

CONCRETE PLACING  
EQUIPMENT

**PARTS MANUAL**

**PARTS**  
GROUP 30  
FIGURE 07  
PAGE 01

THIS PAGE INTENTIONALLY LEFT BLANK.

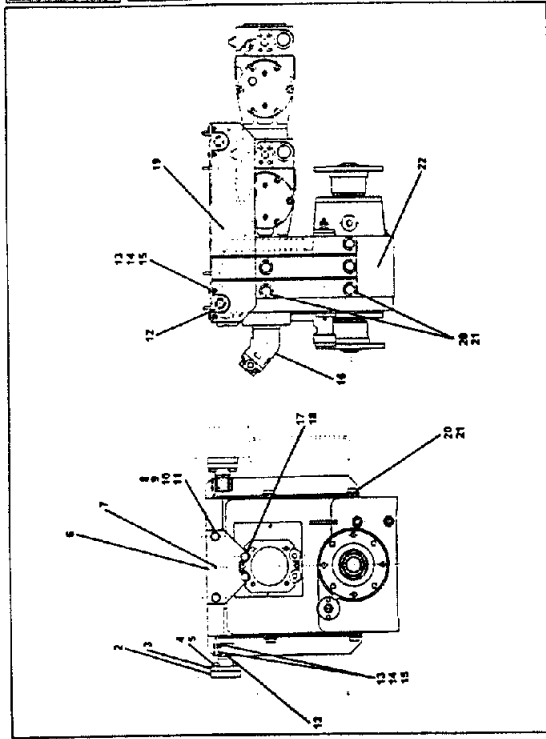
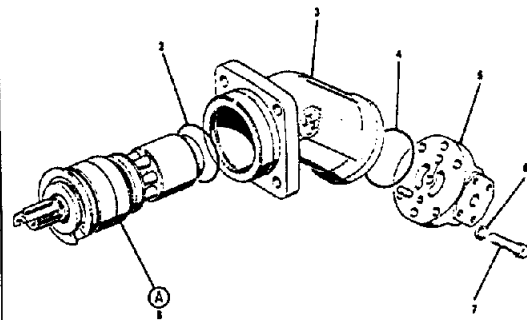
**REED**CONCRETE PLACING  
EQUIPMENT**GROUP 40  
POWER TRAIN INSTALLATION****PARTS  
GROUP 40  
FIGURE 00  
PAGE 01****REED**CONCRETE PLACING  
EQUIPMENT**POWER TRAIN INSTALLATION****PARTS  
GROUP 40  
FIGURE 01  
PAGE 01****REED**CONCRETE PLACING  
EQUIPMENT**BOOM PUMP MOTOR ASSEMBLY****PARTS  
GROUP 40  
FIGURE 02  
PAGE 01****GROUP 40 POWER TRAIN INSTALLATION CONTAINS THE FOLLOWING FIGURES:**

- |                  |                                 |
|------------------|---------------------------------|
| <b>FIGURE 00</b> | <b>TABLE OF CONTENTS</b>        |
| <b>FIGURE 01</b> | <b>POWER TRAIN INSTALLATION</b> |
| <b>FIGURE 02</b> | <b>BOOM PUMP MOTOR ASSEMBLY</b> |
| <b>FIGURE 03</b> | <b>GEAR BOX ASSEMBLY</b>        |

REVISION:

# POWER TRAIN INSTALLATION

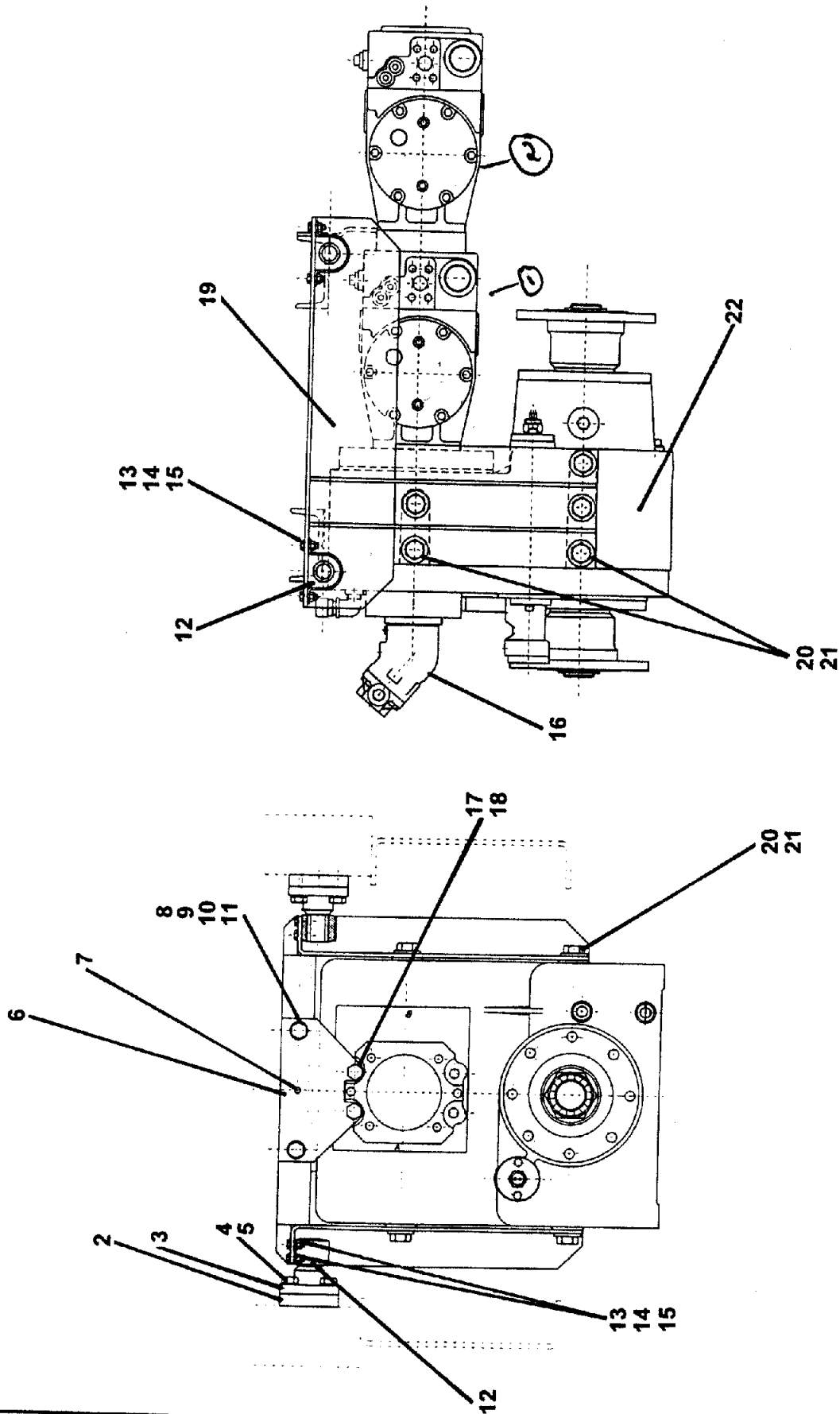

REVISION:

**REED**CONCRETE PLACING  
EQUIPMENT**POWER TRAIN INSTALLATION****PARTS**  
GROUP 40  
FIGURE 01  
PAGE 02

ITEM NO.	REED'S PARTS NO.	DESCRIPTION	QTY
		1 2 3 4 5	
-1	40-01	Installation, Power Train (See Group 10, Figure 01 for NHA)	Ref
2	B-813104	• Plate, Tread	4
3	B-813101	• Axle	4
4	W-101634	• Screw, Hex M16 x 60 (attaching parts)	16
5	W-100506	• Washer (attaching parts)	16
6	B-813105	• Plate, Fixing	1
7	W-102881	• Sleeve, Clamping	1
8	W-102071	• Screw, Hex M16 x 35 (attaching parts)	2
9	W-102893	• Washer (attaching parts)	2
10	W-102330	• Nut, Lock (attaching parts)	2
11	W-103464	• Washer (attaching parts)	2
12	W-103414	• Form, Buffer	4
13	W-101621	• Screw, Hex M8 x 25 (attaching parts)	16
14	W-101625	• Washer (attaching parts)	16
15	W-102111	• Nut (attaching parts)	16
16	40-02 w-103623	• Assembly, Boom Pump Motor (See Group 40, Figure 02 for DET)	1
17		• Screw, Hex M16 x 150 (attaching parts)	4
18	W-102893	• Washer (attaching parts)	4
19	B-813108	• Console	1
20	W-102860	• Screw, Hex M20 x 50 (attaching parts)	10
21	W-102110	• Washer (attaching parts)	10
22	W-103336	• Assembly, Gear Box (See Group 40, Figure 03 for DET)	1

DASH (-) ITEM NOT ILLUSTRATED

① - 800052 - 9DR100KP2C1

② - 800053 - 9DR100KP2AB

REVISION:

**BOOM PUMP MOTOR ASSEMBLY**

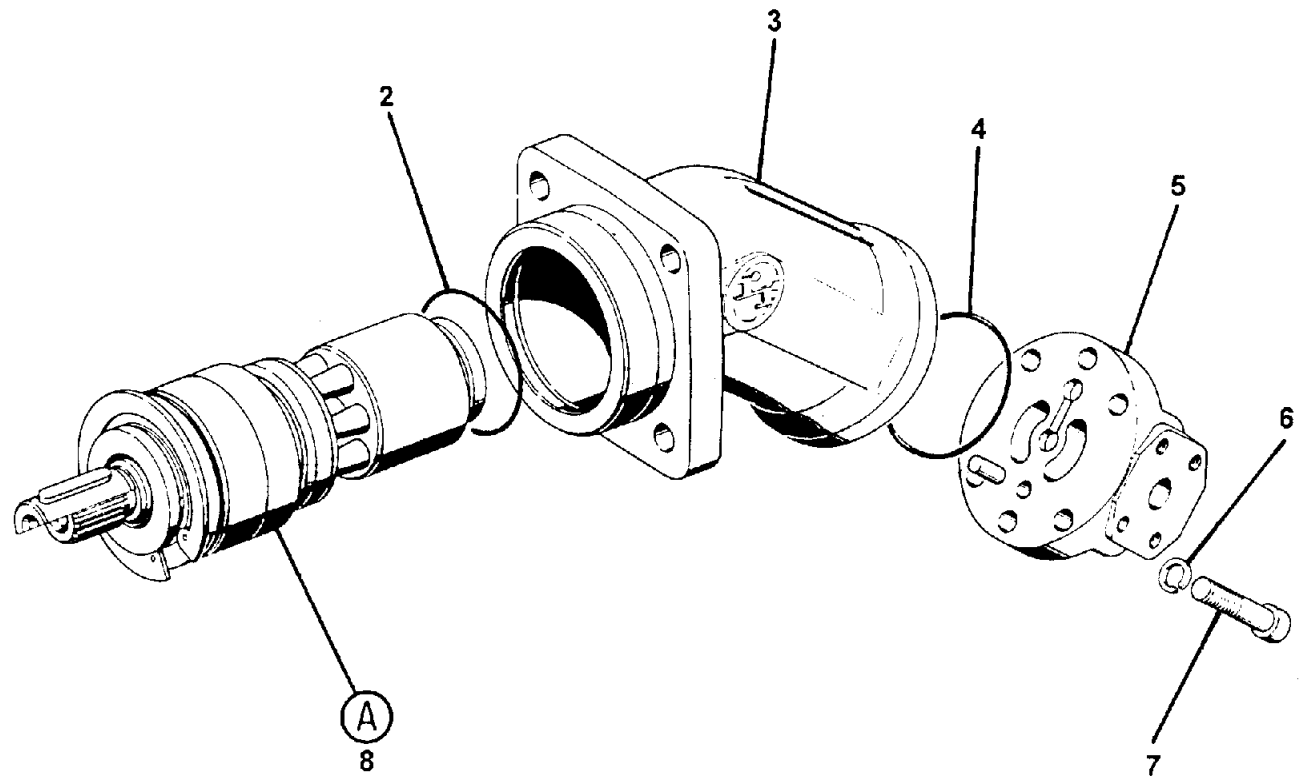



**BOOM PUMP MOTOR ASSEMBLY**

ITEM NO.	REED'S PARTS NO.	DESCRIPTION					QTY
		1	2	3	4	5	
-1	40-02 <del>40-02</del>	Assembly, Boom Pump Motor (See Group 40, Figure 01 for NHA)					Ref
2		• O-Ring					1
3		• Housing					1
4		• O-Ring					1
5		• Plate, Port					1
6		• Washer, Lock					4
7		• Screw, M 6 x 16 - 8.8					4
8		• Sub-Assembly, Rotary					1
9		• • Ring Retaining					1
10		• • Cover					1
11		• • Ring, Shaft Seal					1
12		• • Ring Retaining					1
13		• • Bearing, Tapered Roller					1
14		• • Shim					2
15		• • Shim					2
16		• • Shim					2
17		• • Bearing, Angular Contact Ball					2
18		• • Key, Shaft 4 x 4					1
19		• • Shaft, Drive					1
20		• • Disc					1
21		• • Plate, Retaining					1
22		• • Rivet, 2.5 x 14					7
23		• • Pin, Center					1
24		• • Cup, Spring					4
25		• • Collar, Spring					1
26		• • Shim					1
27		• • Piston					7
28		• • Ring, Steel Sealing					7
29		• • Cylinder					1
30		• • Plate, Control					1
31		• • Pin					1

DASH (-) ITEM NOT ILLUSTRATED

# BOOM PUMP MOTOR ASSEMBLY

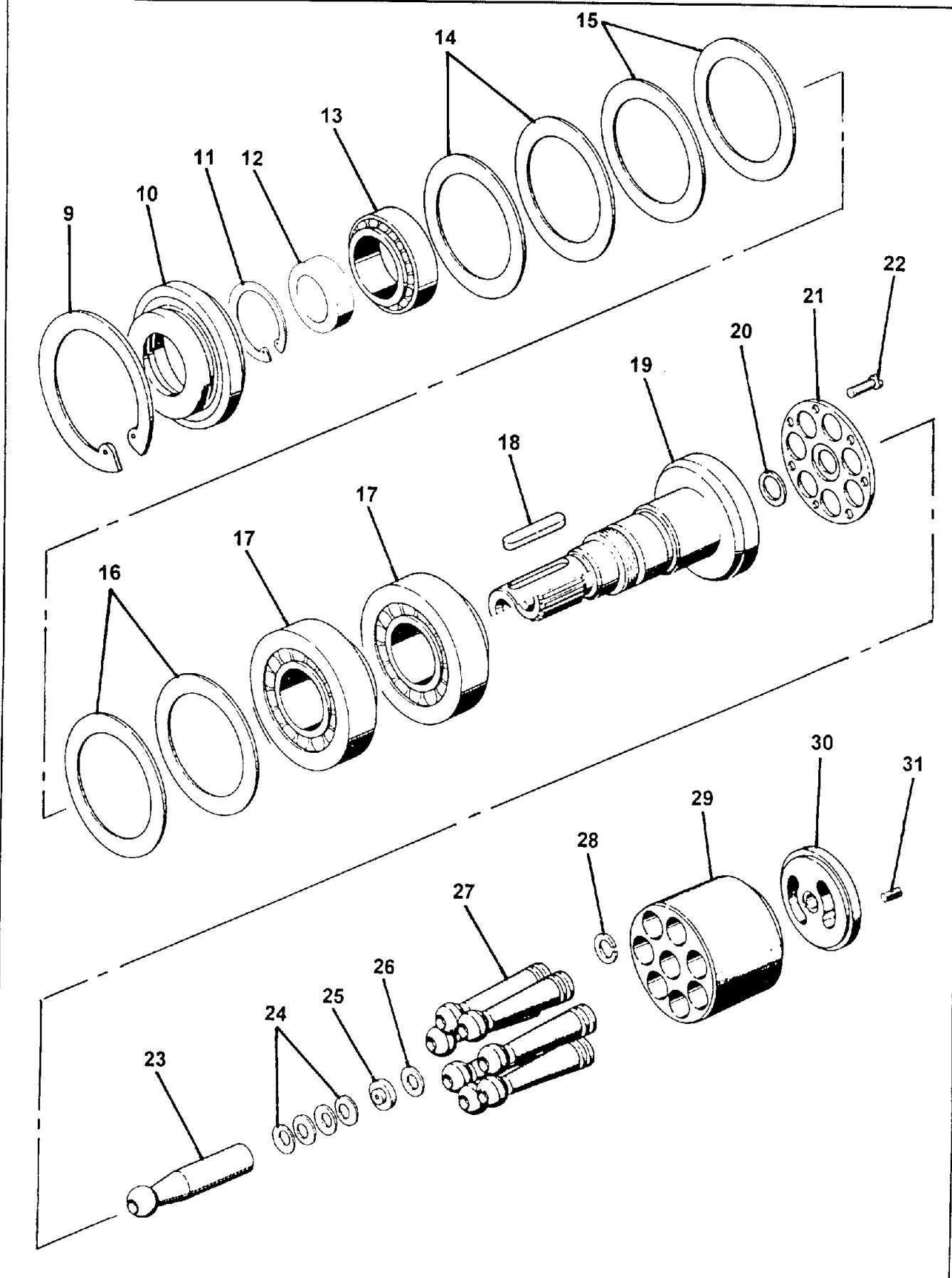

REVISION:

**BOOM PUMP MOTOR ASSEMBLY**

ITEM NO.	REED'S PARTS NO.	DESCRIPTION	QTY
		1 2 3 4 5	
-1	40-02	Assembly, Boom Pump Motor (See Group 40, Figure 01 for NHA)	Ref
2		• O-Ring	1
3		• Housing	1
4		• O-Ring	1
5		• Plate, Port	1
6		• Washer, Lock	4
7		• Screw, M 6 x 16 - 8.8	4
8		• Sub-Assembly, Rotary	1
9		• • Ring Retaining	1
10		• • Cover	1
11		• • Ring, Shaft Seal	1
12		• • Ring Retaining	1
13		• • Bearing, Tapered Roller	1
14		• • Shim	2
15		• • Shim	2
16		• • Shim	2
17		• • Bearing, Angular Contact Ball	2
18		• • Key, Shaft 4 x 4	1
19		• • Shaft, Drive	1
20		• • Disc	1
21		• • Plate, Retaining	1
22		• • Rivet, 2.5 x 14	7
23		• • Pin, Center	1
24		• • Cup, Spring	4
25		• • Collar, Spring	1
26		• • Shim	1
27		• • Piston	7
28		• • Ring, Steel Sealing	7
29		• • Cylinder	1
30		• • Plate, Control	1
31		• • Pin	1

DASH (-) ITEM NOT ILLUSTRATED

# GEAR BOX ASSEMBLY

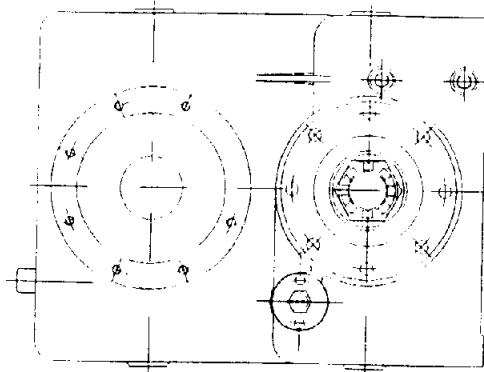
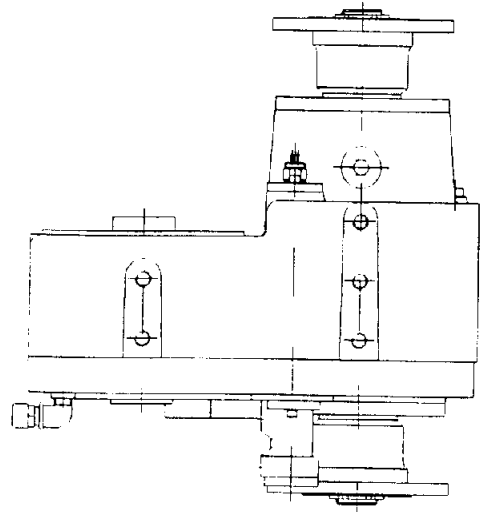
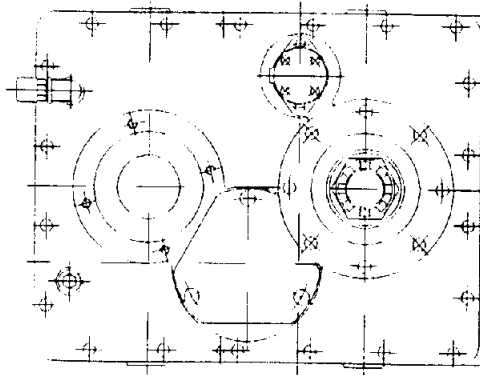

**REED**

CONCRETE PLACING  
EQUIPMENT

**GEAR BOX ASSEMBLY**

**PARTS**

**GROUP 40**

**FIGURE 03**

**PAGE 02**

THIS GROUP 40, FIGURE 03, PARTS NUMBER C- W103336,  
**GEAR BOX ASSEMBLY, DETAIL PARTS LIST**  
IS NOT AVAILABLE THIS REVISION.

REVISION:

THIS PAGE INTENTIONALLY LEFT BLANK.

**GROUP 50 CONTROLS INSTALLATION CONTAINS THE FOLLOWING FIGURES:**

- |                  |   |
|------------------|---|
| <b>FIGURE 00</b> | <b>TABLE OF CONTENTS</b>                    |
| <b>FIGURE 01</b> | <b>CONTROLS INSTALLATION</b>                |
| <b>FIGURE 02</b> | <b>RADIO REMOTE CONTROL ASSEMBLY</b>        |
| <b>FIGURE 03</b> | <b>WIRE REMOTE CONTROL ASSEMBLY</b>         |
| <b>FIGURE 04</b> | <b>BOOM FUNCTION CONTROL VALVE ASSEMBLY</b> |
| <b>FIGURE 05</b> | <b>SHUNT ASSEMBLY</b>                       |
| <b>FIGURE 06</b> | <b>BOOM PUMP CONTROL PANEL ASSEMBLY</b>     |

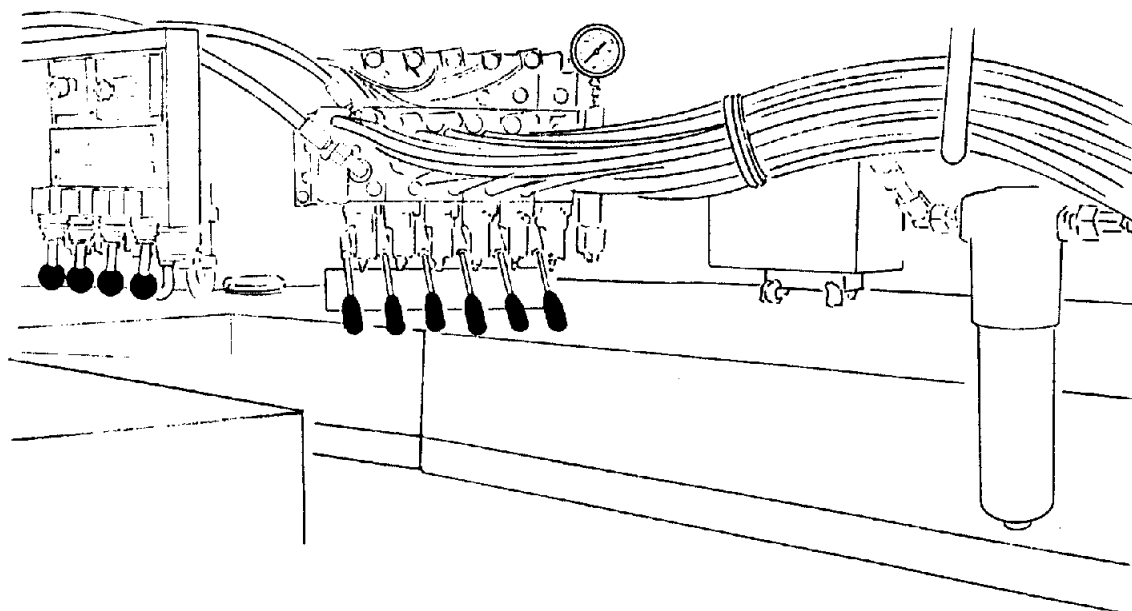

**REED**

CONCRETE PLACING  
EQUIPMENT

# CONTROL INSTALLATION

**PARTS**

**GROUP 50**

**FIGURE 01**

**PAGE 01**

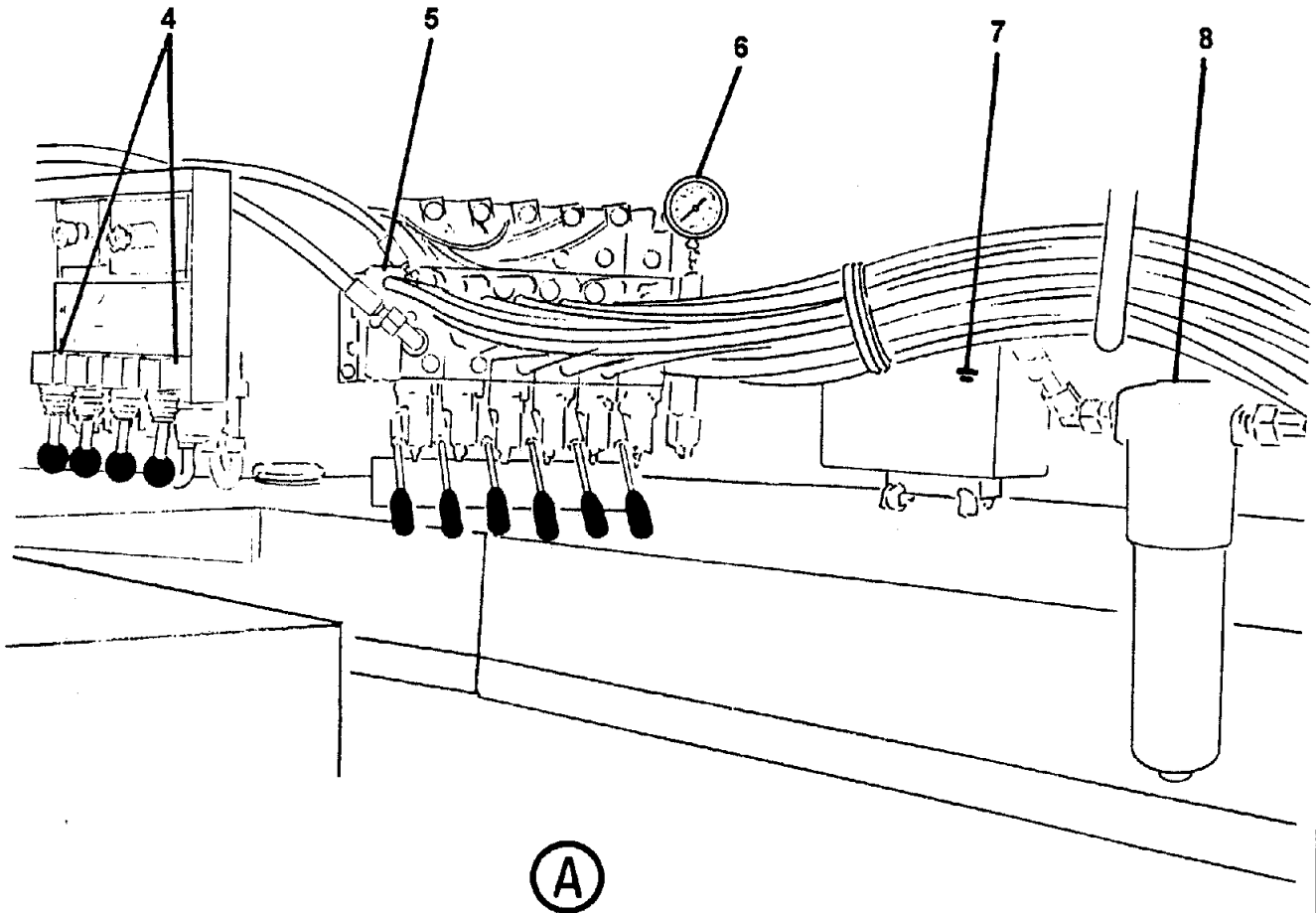
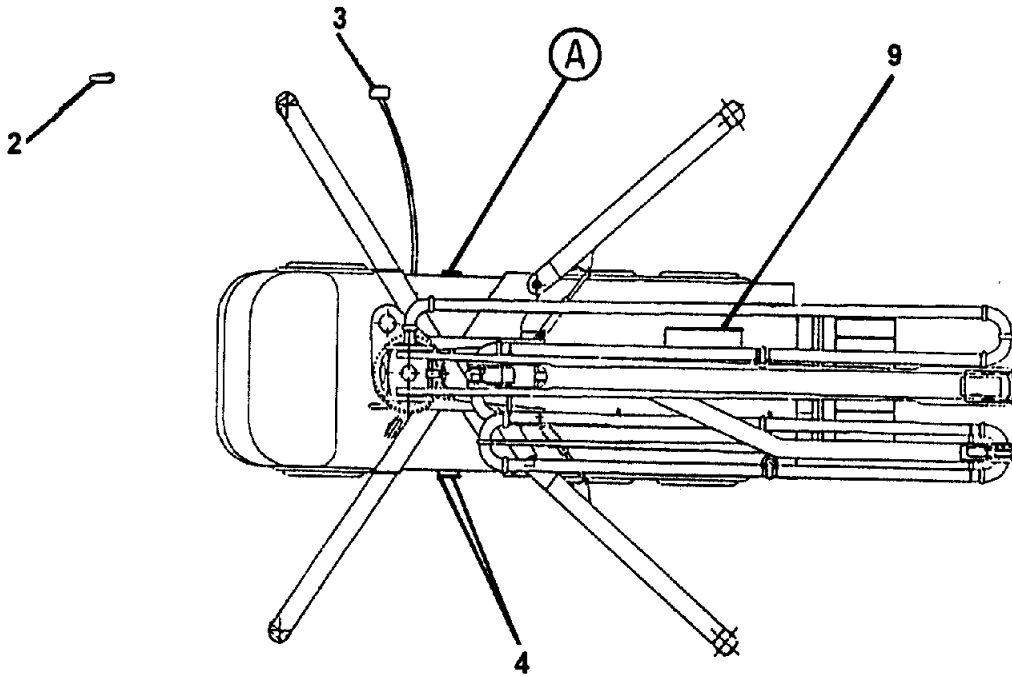

REVISION:



**REED**CONCRETE PLACING  
EQUIPMENT**CONTROL INSTALLATION****PARTS  
GROUP 50  
FIGURE 01  
PAGE 02**

ITEM NO.	REED 'S PARTS NO.	DESCRIPTION	QTY
		1 2 3 4 5	
-1	50-01	Assembly, Control Box (See Group 10, Figure 01 for NHA)	Ref
2	50-02	• Assembly, Radio Remote Control (See Group 50, Figure 02 for DET)	1
3	50-03	• Assembly, Wire Remote Control (See Group 50, Figure 03 for DET)	1
4	C-AVRTC-L-38	• Lever, Outrigger Function	8
5	C-DD002	• Assembly, Boom Function Control Valve (See Group 50, Figure 04 for DET)	1
6	C-DM000	• Gauge, Pressure	1
7	C-VW00411	• Assembly, Shunt (See Group 50, Figure 05 for DET)	1
8	C-DF000	• Filter, Discharge Hydraulic	1
9	800050	• Assembly, Boom Pump Control Panel (See Group 50, Figure 06 for DET)	1

DASH (-) ITEM NOT ILLUSTRATED

REVISION:

**RADIO REMOTE CONTROL ASSEMBLY**

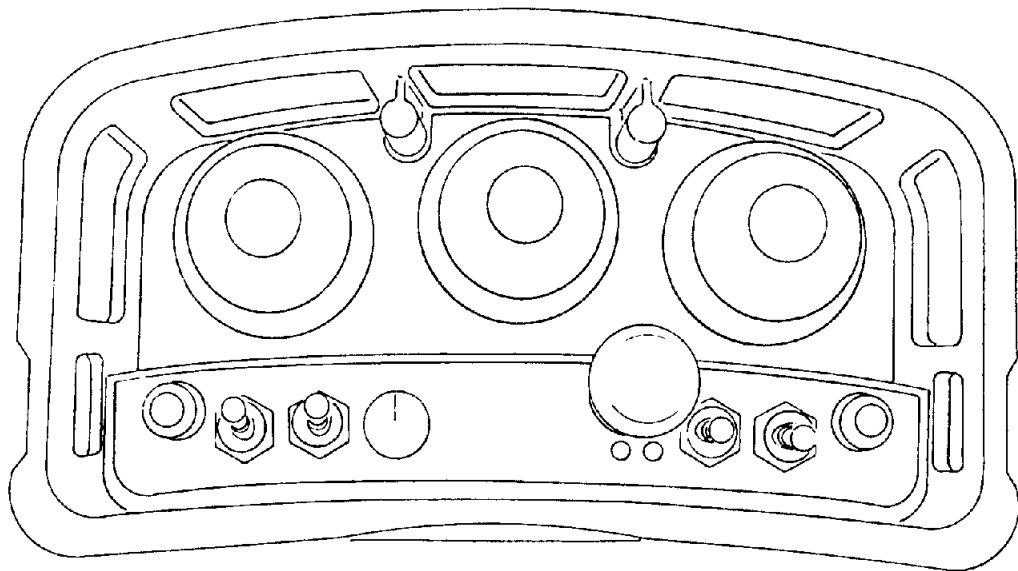

**REED**

CONCRETE PLACING  
EQUIPMENT

**RADIO REMOTE CONTROL ASSEMBLY**

**PARTS**  
GROUP 50  
FIGURE 02  
PAGE 02

THIS GROUP 50, FIGURE 02, PARTS NUMBER 50-02,  
**RADIO REMOTE CONTROL ASSEMBLY,**  
DETAIL PARTS LIST IS NOT AVAILABLE THIS REVISION.

REVISION:

**REED**

CONCRETE PLACING  
EQUIPMENT

# WIRE REMOTE CONTROL ASSEMBLY

PARTS  
GROUP 50  
FIGURE 03  
PAGE 01

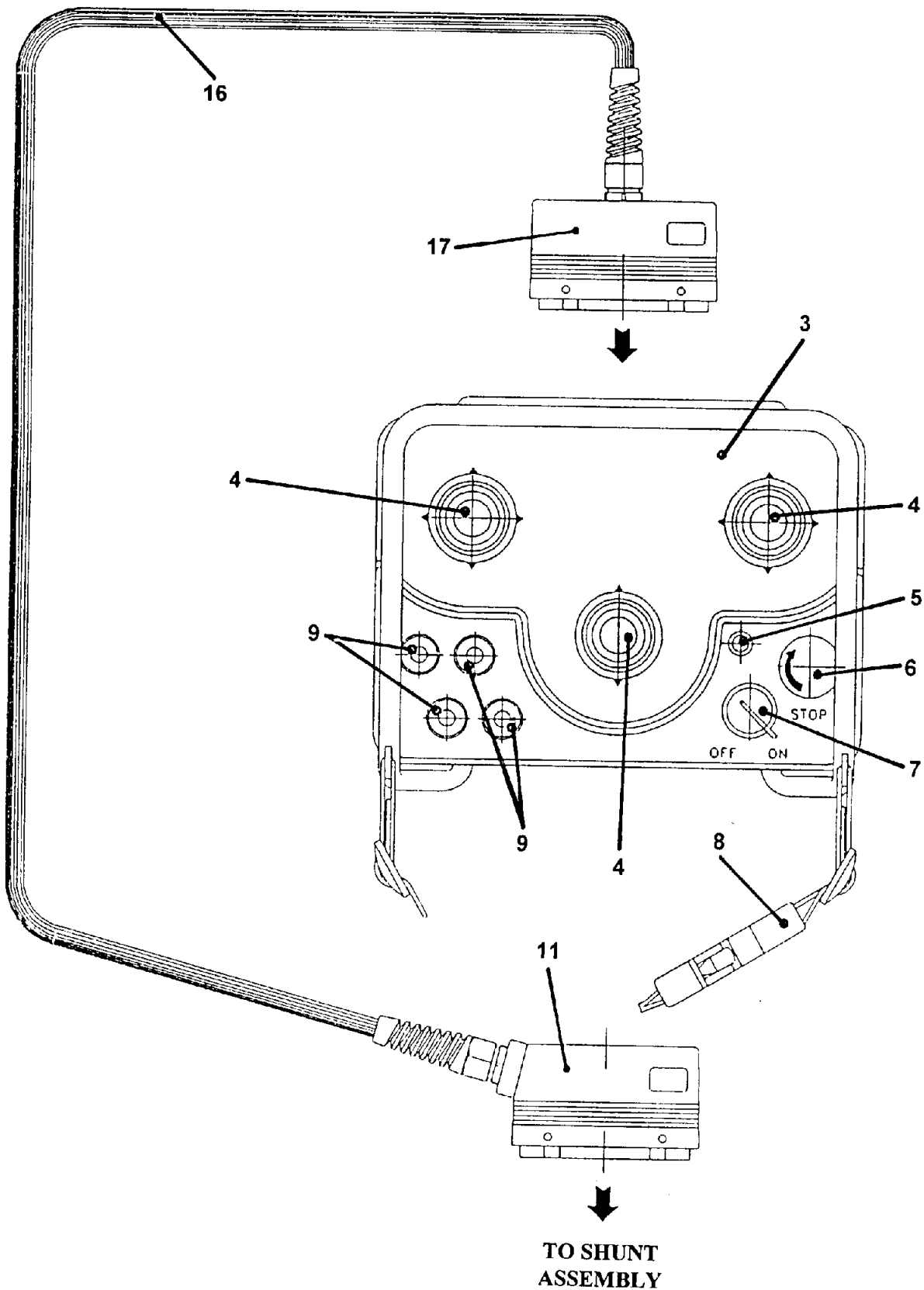

REVISION:



# WIRE REMOTE CONTROL ASSEMBLY

**PARTS**  
**GROUP 50**  
**FIGURE 03**  
**PAGE 02**

ITEM NO.	REED'S PARTS NO.	DESCRIPTION	QTY
		1 2 3 4 5	
-1	50-03	Assembly, Wire Remote Control (See Group 50, Figure 01 for NHA)	Ref
-2	C-VW00264	• Sub-Assembly, Remote Control	1
3	C-WW00203	• • Box, Control	1
4	C-WW00232	• • Switch, Lever	3
5	C-WW01023	• • Light, Battery Check	1
6	C-WW00035	• • Switch, Emergency Press	1
7	C-WW00377	• • Switch, Key	1
8	C-EC001	• • Belt, Shoulder	1
9	C-WW00399	• • Switch	4
-10	C-VW00265	• Sub-Assembly, Remote Control	1
11		• • Contact, 24 Pins	1
-12	C-WW00216	• • • Case, Plug	1
-13	C-WW00153	• • • Plug	1
-14	C-WW00195	• • • Cable, Press	1
-15	C-WW00248	• • • Reduction	1
16	C-WW00197	• • Cable, Electric 27 Wire 30 m	1
17		• • Contact, 24 Points	1
-18	C-WW00152	• • • Case, Plug	1
-19	C-WW00154	• • • Plug	1
-20	C-WW00195	• • • Cable, Press	1
-21	C-WW00248	• • • Reduction	1

DASH (-) ITEM NOT ILLUSTRATED

REVISION:

# BOOM FUNCTION CONTROL VALVE ASSEMBLY

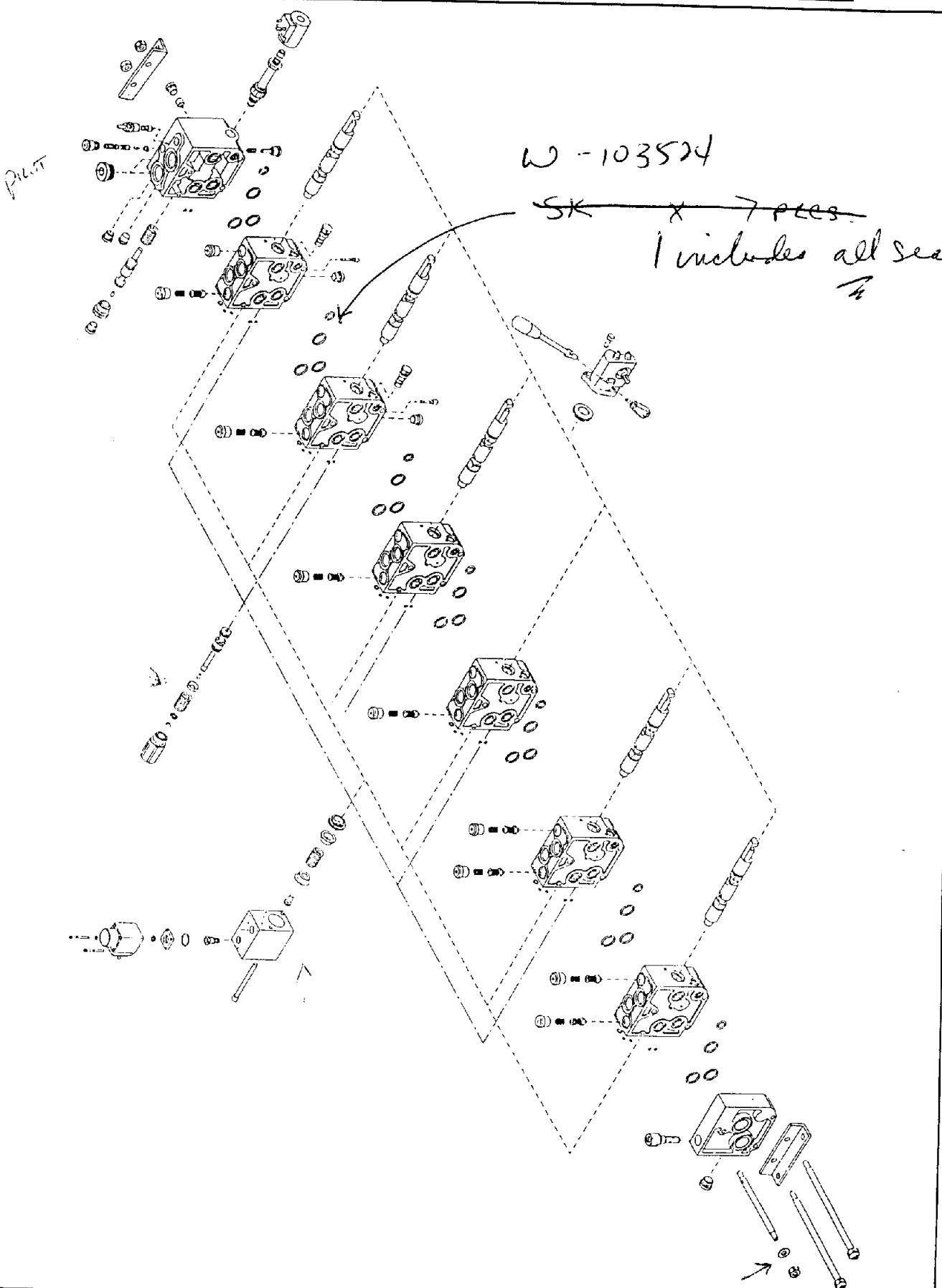

REVISION:

**REED**

CONCRETE PLACING  
EQUIPMENT

**BOOM FUNCTION CONTROL  
VALVE ASSEMBLY**

**PARTS**  
GROUP 50  
FIGURE 04  
PAGE 02

THIS GROUP 50, FIGURE 04, PARTS NUMBER C-DD002,  
**BOOM FUNCTION CONTROL VALVE ASSEMBLY,**  
DETAIL PARTS LIST IS NOT AVAILABLE THIS REVISION.

REVISION:

# SHUNT ASSEMBLY

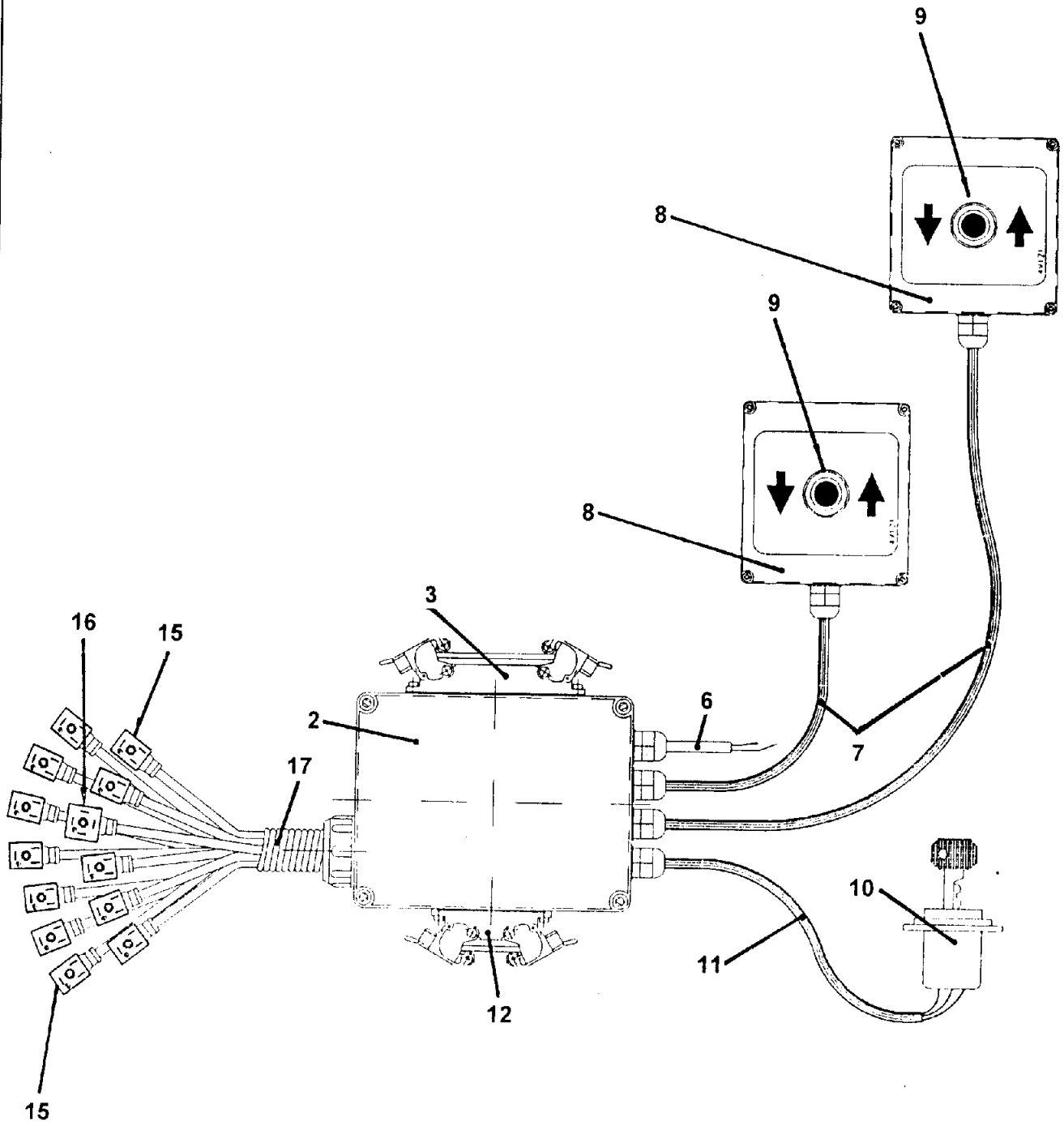



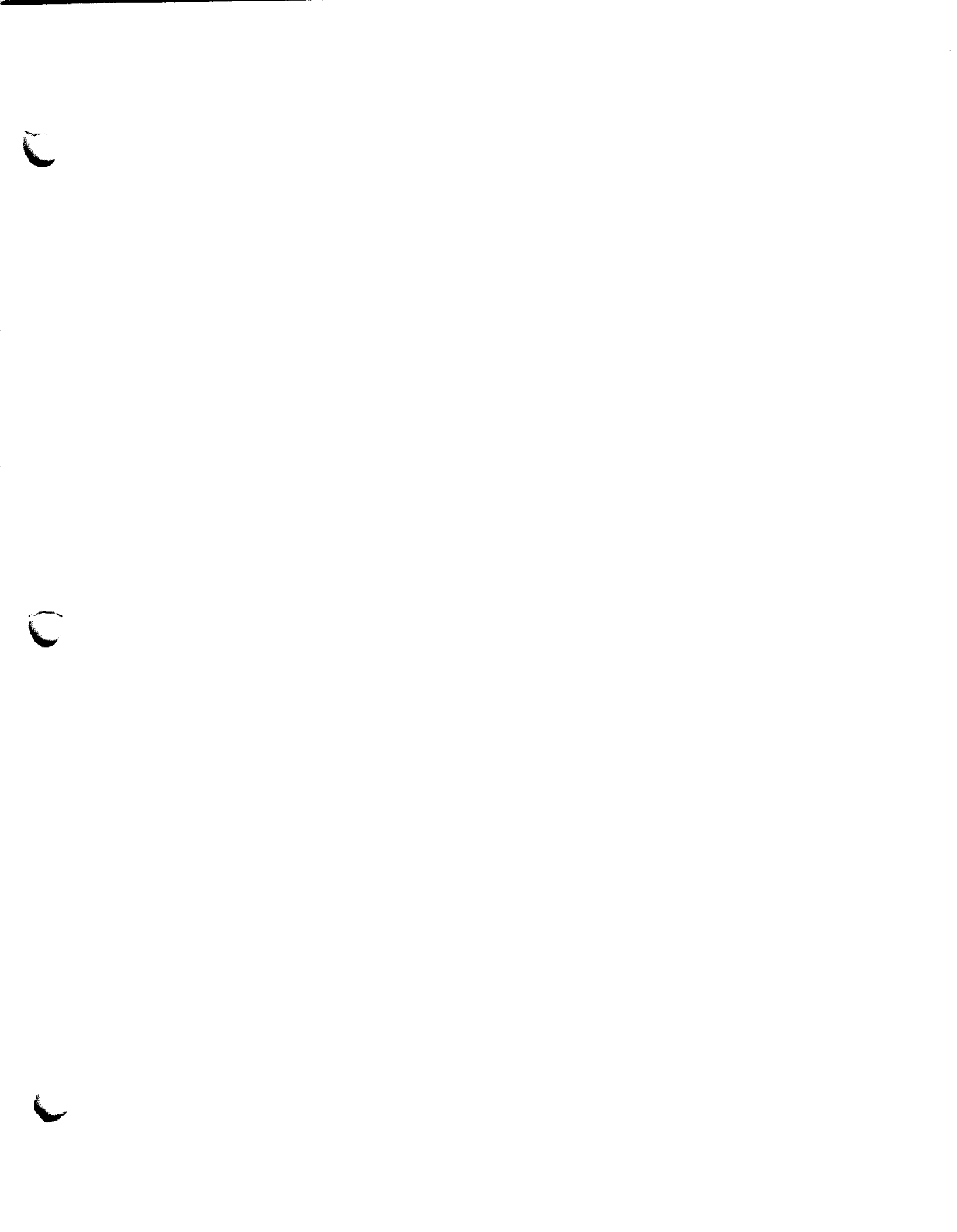

## SHUNT ASSEMBLY

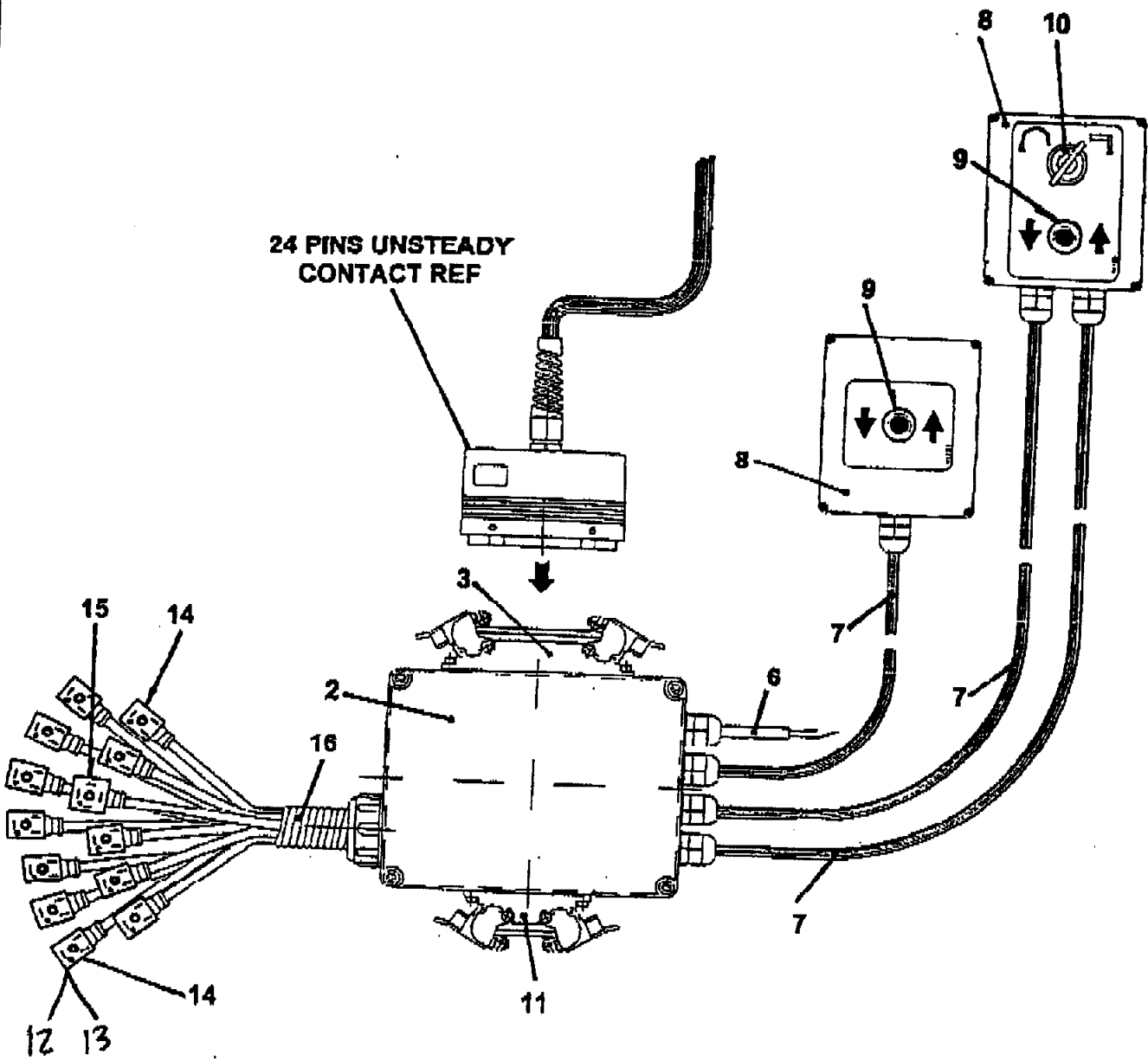

12 PLUG  
13 COIL OR INSERT → W-104691  
W-102760 INTERFRICTION Light

**REED**CONCRETE PLACING  
EQUIPMENT**SHUNT ASSEMBLY****PARTS  
GROUP 50  
FIGURE 05  
PAGE 02**

ITEM NO.	REED'S PARTS NO.	DESCRIPTION	QTY
		1 2 3 4 5	
-1	C-VW00411	Assembly, Shunt (See Group 50, Figure 01 for NHA)	Ref
2	C-WW00230	• Box, Connector	1
3		• Plug, 24 Points Contact	1
-4	C-WW00154	• • Plug	1
-5	C-WW00167	• • Case, Plug	1
6	C-WW00116	• Cable, Electric 1.6 m	1
7	C-WW00265	• Cable, Electric 4 m	2
8	C-ES001	• Pin, Cylindrical	2
9	C-EI001	• Box, Junction	2
10	C-WW00190	• Switch, 2 Position Key	1
11	C-WW00265	• Cable, Electric	1
12		• Plug, 24 Points Auxiliary Contact	1
-13	C-WW00011	• • Plug	1
-14	C-WW00037	• • Case, Plug	1
15	C-WW00065	• Plug, Rectangular with Cable	12
16	C-WW00175	• Plug, Square with Electric Cable	1
17	C-WW00100	• Cable, 1.5 m Sheath	1

DASH (-) ITEM NOT ILLUSTRATED

REVISION:

**BOOM PUMP CONTROL  
PANEL ASSEMBLY**

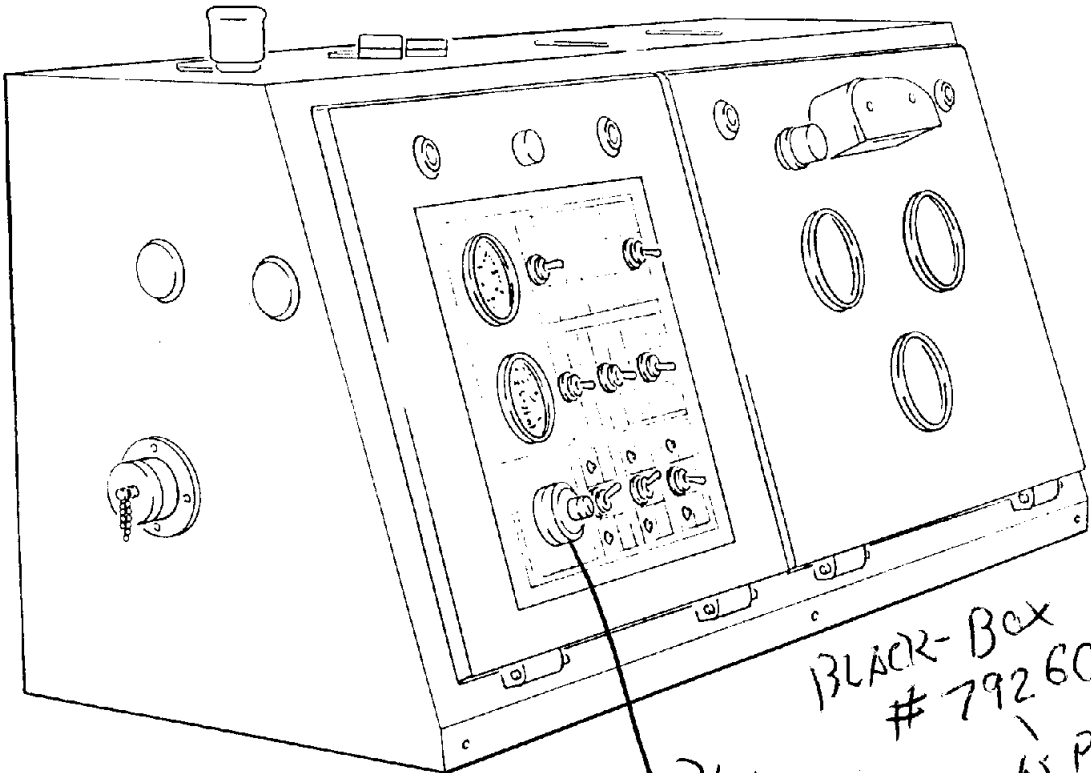

BLACK-BOX  
# 79260  
PIN 77642 AS PER JARKIS  
POT & knob

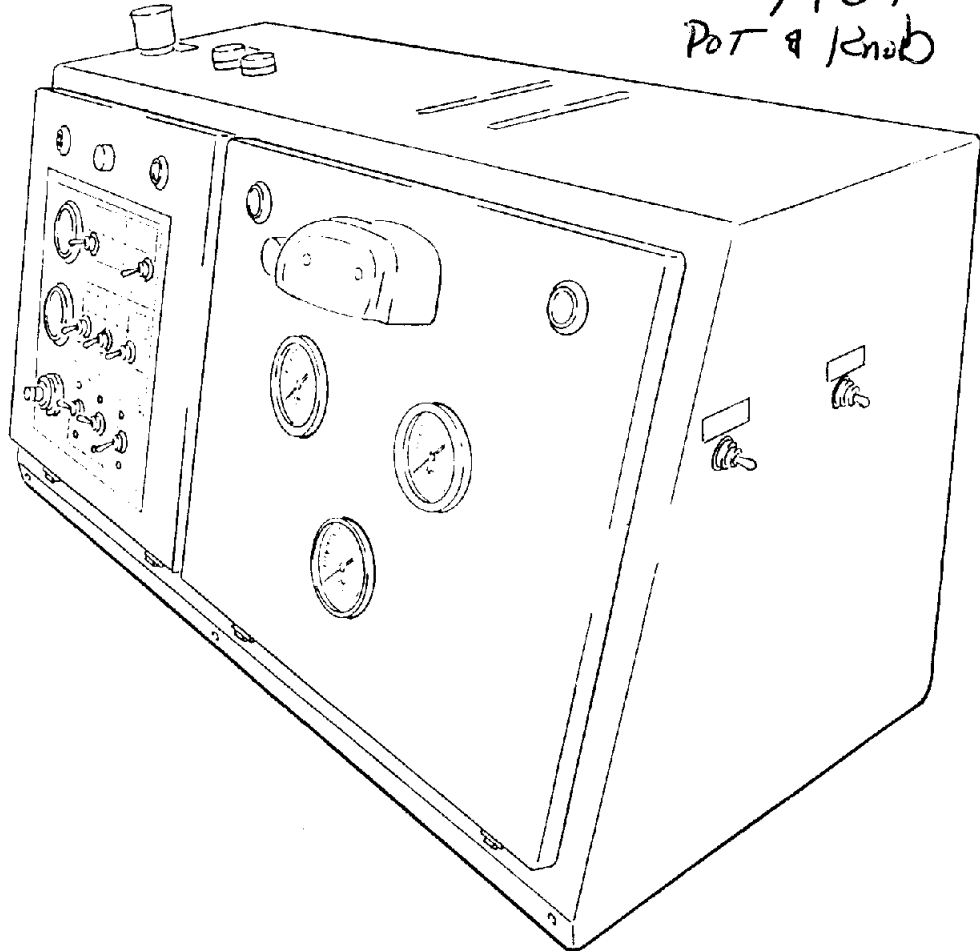



**BOOM PUMP CONTROL  
PANEL ASSEMBLY**

**PARTS  
GROUP 50  
FIGURE 06  
PAGE 02**

THIS GROUP 50, FIGURE 06, PARTS NUMBER 800050,  
**BOOM PUMP CONTROL PANEL ASSEMBLY,**  
DETAIL PARTS LIST IS NOT AVAILABLE THIS REVISION.

**REED**

CONCRETE PLACING  
EQUIPMENT

**PARTS MANUAL**

**PARTS**  
GROUP 50  
FIGURE 07  
PAGE 01

THIS PAGE INTENTIONALLY LEFT BLANK.

REVISION:

**GROUP 60 PUMPING TRAIN INSTALLATION CONTAINS THE FOLLOWING FIGURES:**

<b>FIGURE 00</b>	TABLE OF CONTENTS
<b>FIGURE 01</b>	PUMPING TRAIN INSTALLATION
<b>FIGURE 02</b>	SWING VALVE ASSEMBLY (I)
<b>FIGURE 03</b>	SWING VALVE ASSEMBLY (II)
<b>FIGURE 04</b>	CONCRETE CYLINDER ASSEMBLY
<b>FIGURE 05</b>	WATER BOX ASSEMBLY
<b>FIGURE 06</b>	HYDRAULIC DRIVE CYLINDER ASSEMBLY
<b>FIGURE 07</b>	DRIVE CYLINDER SUB-ASSEMBLY
<b>FIGURE 08</b>	CENTRAL LUBRICATION SYSTEM
<b>FIGURE 09</b>	VALVES INSTALLATION
<b>FIGURE 10</b>	SWING CIRCUIT CYLINDER VALVE ASSEMBLY
<b>FIGURE 11</b>	DIRECTIONAL CONTROL VALVE SUB-ASSEMBLY
<b>FIGURE 12</b>	UNLOADER MANIFOLD SYSTEM

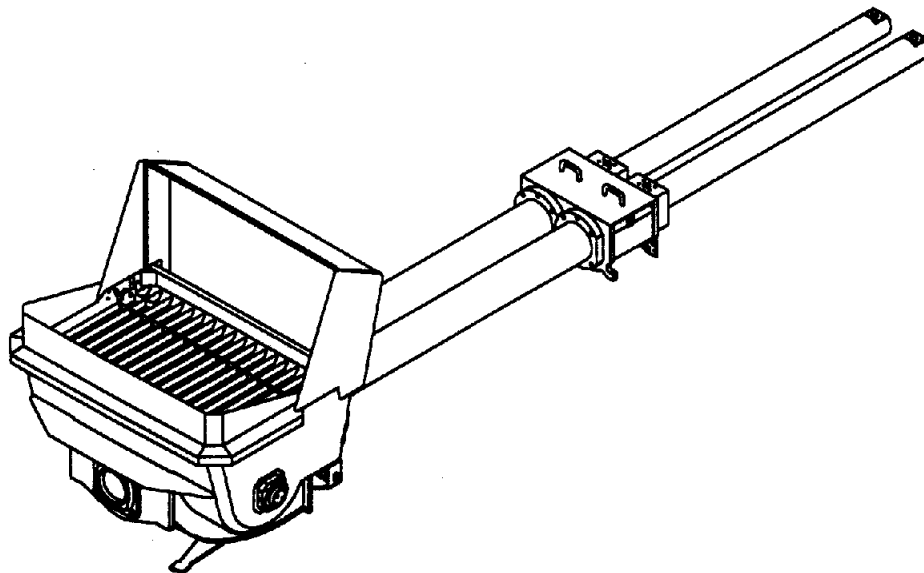

**REED**

CONCRETE PLACING  
EQUIPMENT

**PUMPING TRAIN INSTALLATION**

**PARTS  
GROUP 60  
FIGURE 01  
PAGE 01**

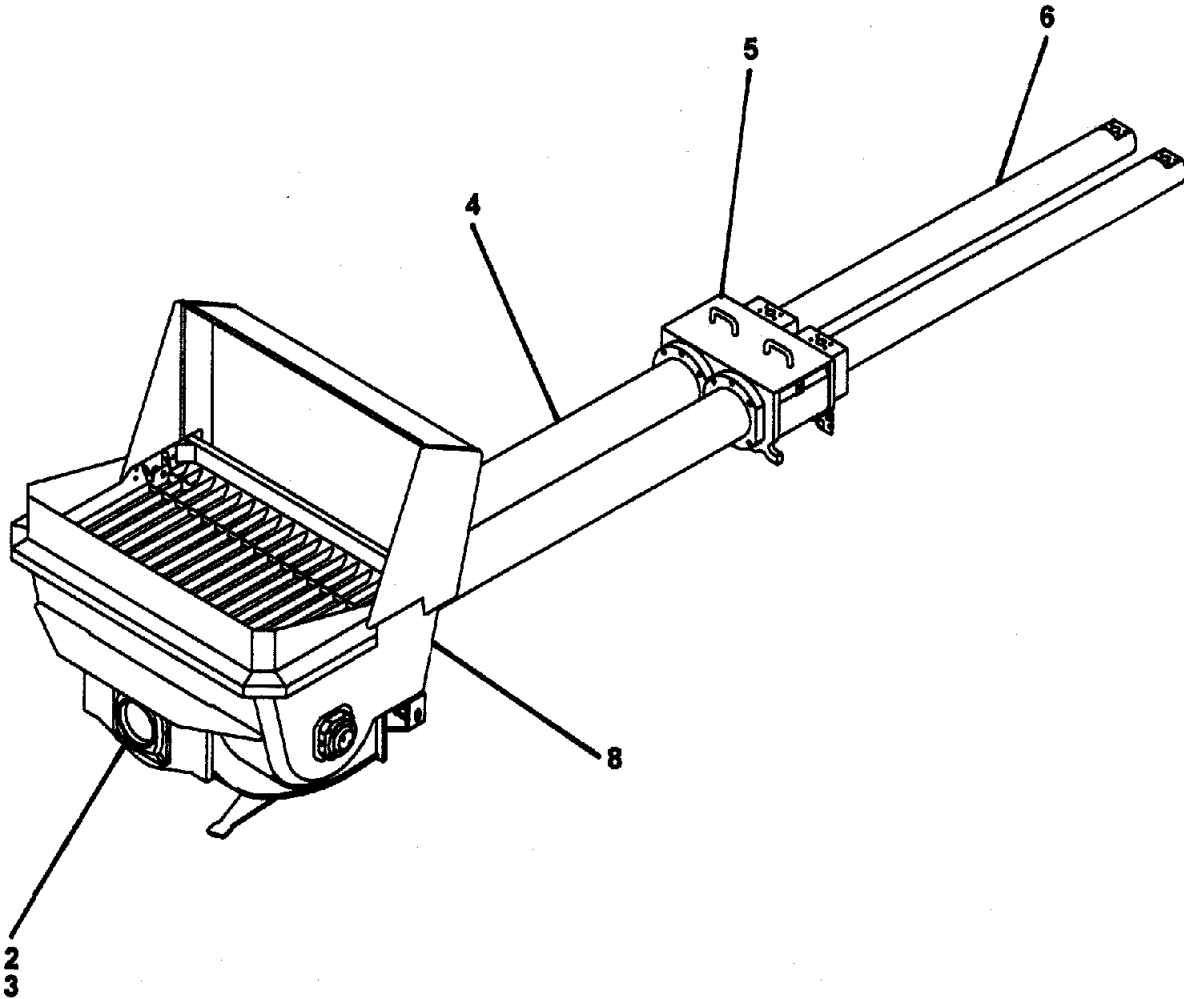

REVISION:



**REED**CONCRETE PLACING  
EQUIPMENT**PUMPING TRAIN INSTALLATION****PARTS  
GROUP 60  
FIGURE 01  
PAGE 02**

ITEM NO.	REED'S PARTS NO.	DESCRIPTION					QTY
		1	2	3	4	5	
-1	60-01	Installation, Pumping Train (See Group 10, Figure 01 for NHA)					Ref
2	B-174020	• Assembly, Swing Valve (See Group 60, Figure 02 for DET)					1
-3	B-174030	• Assembly, Tilting Drive (See Group 60, Figure 03 for DET)					1
4	B-124013	• Assembly, Concrete Cylinder (See Group 60, Figure 04 for DET)					1
5	B-143000	• Assembly, Water Box (See Group 60, Figure 05 for DET)					1
6	60-06	• Assembly, Hydraulic Drive Cylinder (See Group 60, Figure 06 for DET)					1
-7	B-184000	• System, Central Lubrication (See Group 60, Figure 08 for DET)					1
8	20-01	• Installation, Hopper (See Group 20, Figure 01 for REF)					Ref
-9	60-09	• Installation, Valves (See Group 60, Figure 09 for DET)					1

DASH (-) ITEM NOT ILLUSTRATED

REVISION:

**REED**

CONCRETE PLACING  
EQUIPMENT

# SWING VALVE ASSEMBLY (I)

**PARTS**  
GROUP 60  
FIGURE 02  
PAGE 01

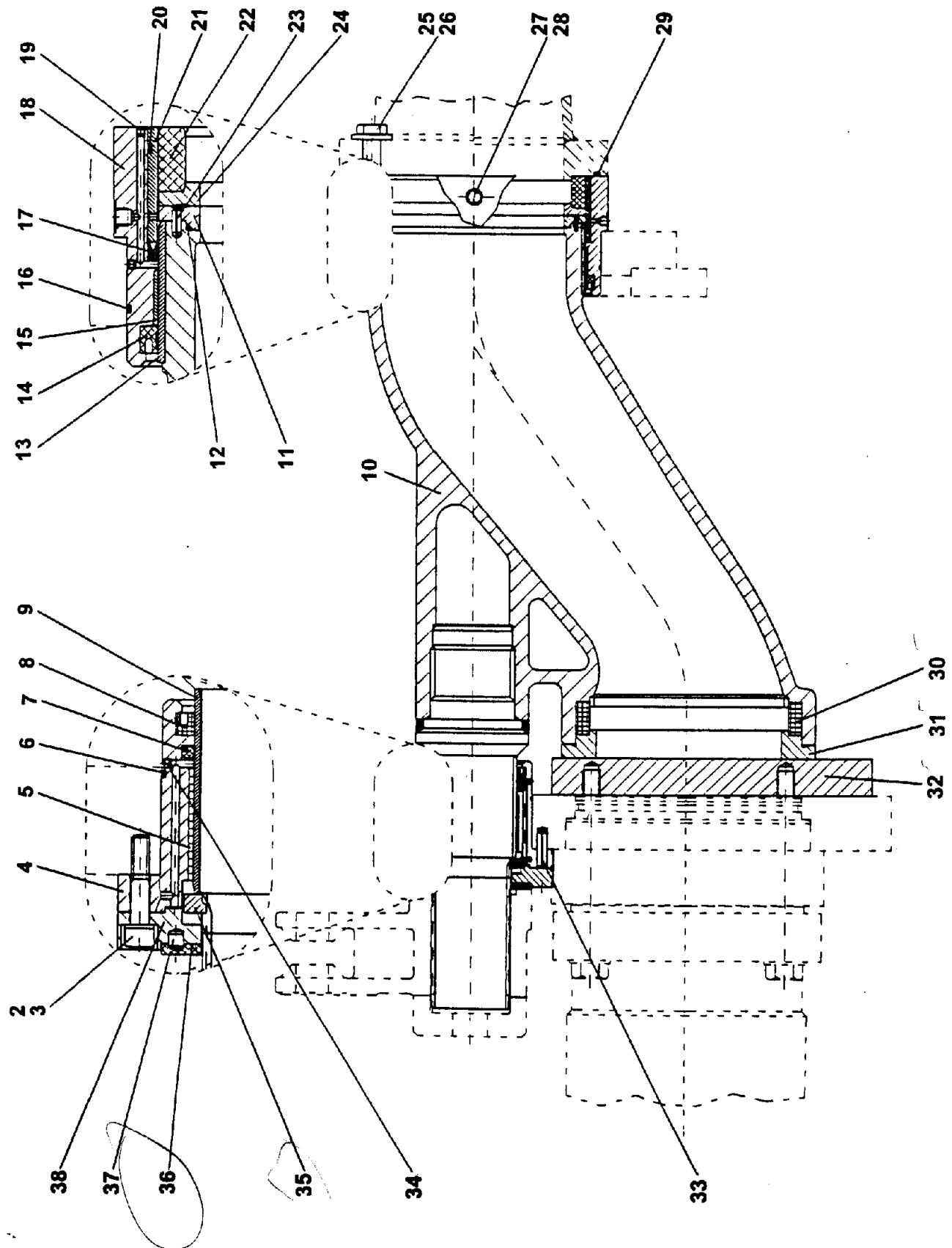

REVISION:

**REED**CONCRETE PLACING  
EQUIPMENT**SWING VALVE ASSEMBLY (I)****PARTS  
GROUP 60  
FIGURE 02  
PAGE 02**

ITEM NO.	REED'S PARTS NO.	DESCRIPTION					QTY
		1	2	3	4	5	
-1	B-174020	Assembly, Swing Valve (See Group 60, Figure 01 for NHA)					Ref
2	W-103151	• Screw, M12 x 45					3
3	W-103113	• Washer, Spring A12					3
4	B-174024	• Housing, Small Bearing					1
5 x	W-100237	• Bushing					1
6 x	W-100486	• O-Ring, 124 x 3					2
7 x	W-100485	• O-Ring, 95 x 7					2
8 x	<del>W-100484</del>	• Ring, Groove 95 <del>95</del> B-173077					1
9 x	B-172105	• Housing, Small Bearing					1
10	B-174021	• Valve, Swing DN 200					2
11	B-174027	• Ring, Sliding					1
12 x	W B-100625	• O-Ring, 205 x 3					1
13 x	B-172107	• Bushing, Big Bearing					1
14	<del>W-100479</del>	• Ring, Groove B-173078					1
15 x	W-100236	• Bushing					1
16 x	W-100481	• O-Ring, 265 x 3					1
17 x	W-103078	• Foreseal, 240					1
18	B-174222 x	• Housing, Big Bearing					1
19	W-100499	• Screw, Set M5 x 5					2
20 x	W-103365	• O-Ring, 244 x 3					1
21	B-174023	• Ring, Spacer					1
22	W-100262	• Ring, Tension -					1
23	W-103077	• Pin, Spring Type Straight 5 x 15					2
24	B-174028	• Ring, Sliding					1
25	W-101589	• Screw, Hex M20 x 120					4
26	W-102110	• Washer, A20					4
27	W-101621	• Screw, Hex M8 x 25					1
28	W-101269	• Ring					1
29 x	W-101588	• O-Ring, 260 x 5					1
30 x	<del>W-100263</del>	• Ring, Tension W-103378					1
31 x	<del>B-172109</del>	• Ring, Wear B-174087					1
32 x	B-172112	• Plate, Spectacle					1
33	W-103076	• Pin, Spring Type Straight 12 x 40					1
34	W-102710	• Screw, Set M4 x 4					4
35	B-174026	• Profile					1
36	B-173012	• Washer, Axial Bearing PHENOLIC					1
37	W-103080	• Pin, Cylindrical					1
38	B-174025	• Flange					1

DASH (-) ITEM NOT ILLUSTRATED

REVISION:

**REED**

CONCRETE PLACING  
EQUIPMENT

# SWING VALVE ASSEMBLY (II)

PARTS  
GROUP 60  
FIGURE 03  
PAGE 01

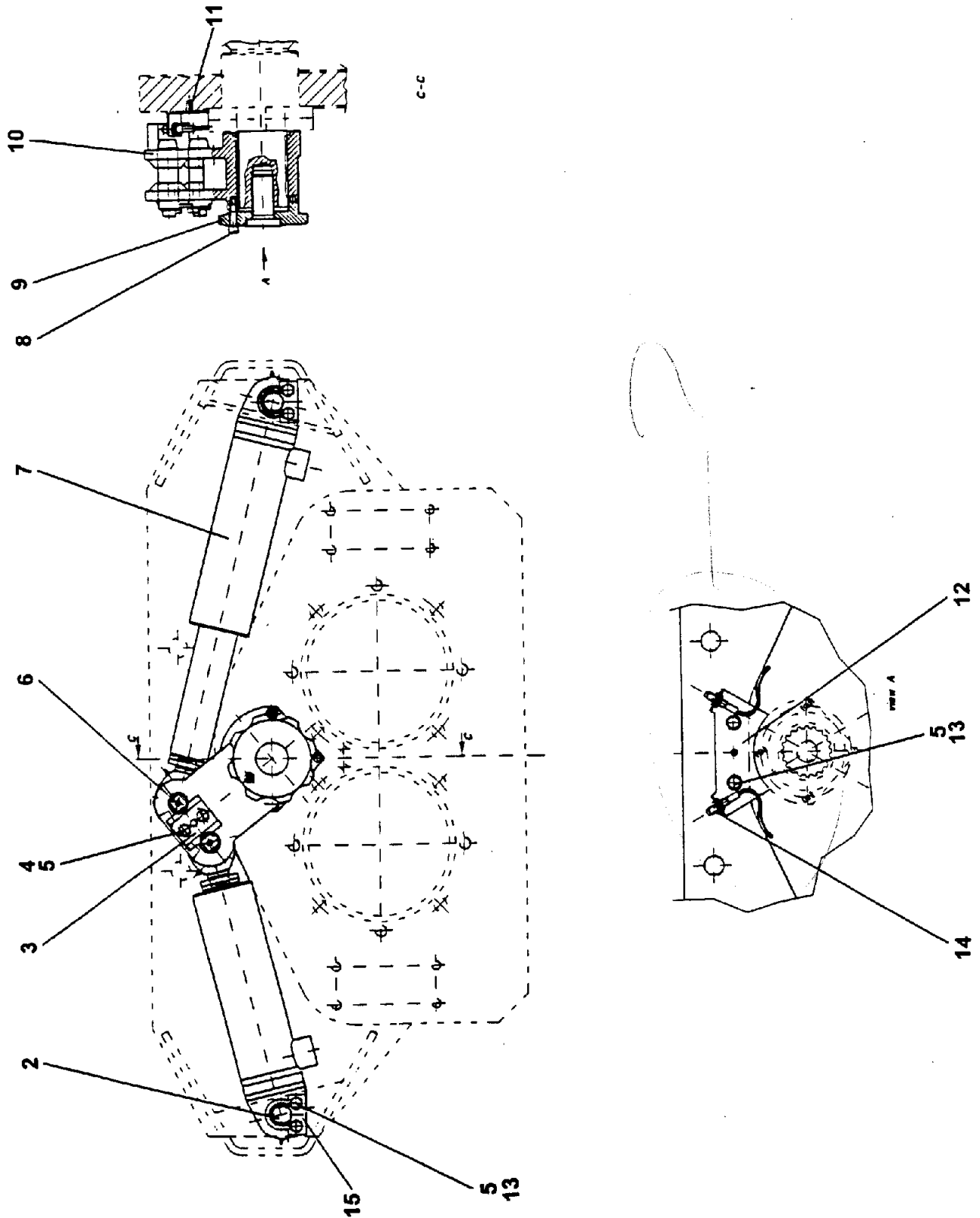

REVISION:

**REED**CONCRETE PLACING  
EQUIPMENT**SWING VALVE ASSEMBLY (II)****PARTS  
GROUP 60  
FIGURE 03  
PAGE 02**

ITEM NO.	REED'S PARTS NO.	DESCRIPTION					QTY
		1	2	3	4	5	
-1	B-174030	Assembly, Tilting Drive (See Group 60, Figure 01 for NHA)					Ref
2	B-173066	• Pin, Safety					2
3	B-174083	• Plate, Key					1
4	W-102107	• Screw, Hex M12 x 30					2
5	W-102877	• Washer, A12					8
6	B-173019	• Pin					2
7	<del>W-102263</del> 9053	• Assembly, Tilting Cylinder					2
8	B-174035	• Screw, Hex M10 x 50 (attaching parts)					1
9	B-174032	• Plate, Tension					1
10	B-174031	• Lever, Tilting					1
11	W-102881	• Pin, Spring Type Straight					1
12	B-174084	• Bracket, Sensor					1
13	W-101001	• Bolt, M12 x 25					6
14	W-103124	• Sensor, Inductive					2
15	B-173067	• Plate, Safety Pin					2

DASH (-) ITEM NOT ILLUSTRATED

REVISION:

**REED**

CONCRETE PLACING  
EQUIPMENT

**CONCRETE CYLINDER ASSEMBLY**

**PARTS**

GROUP 60

FIGURE 04

PAGE 01

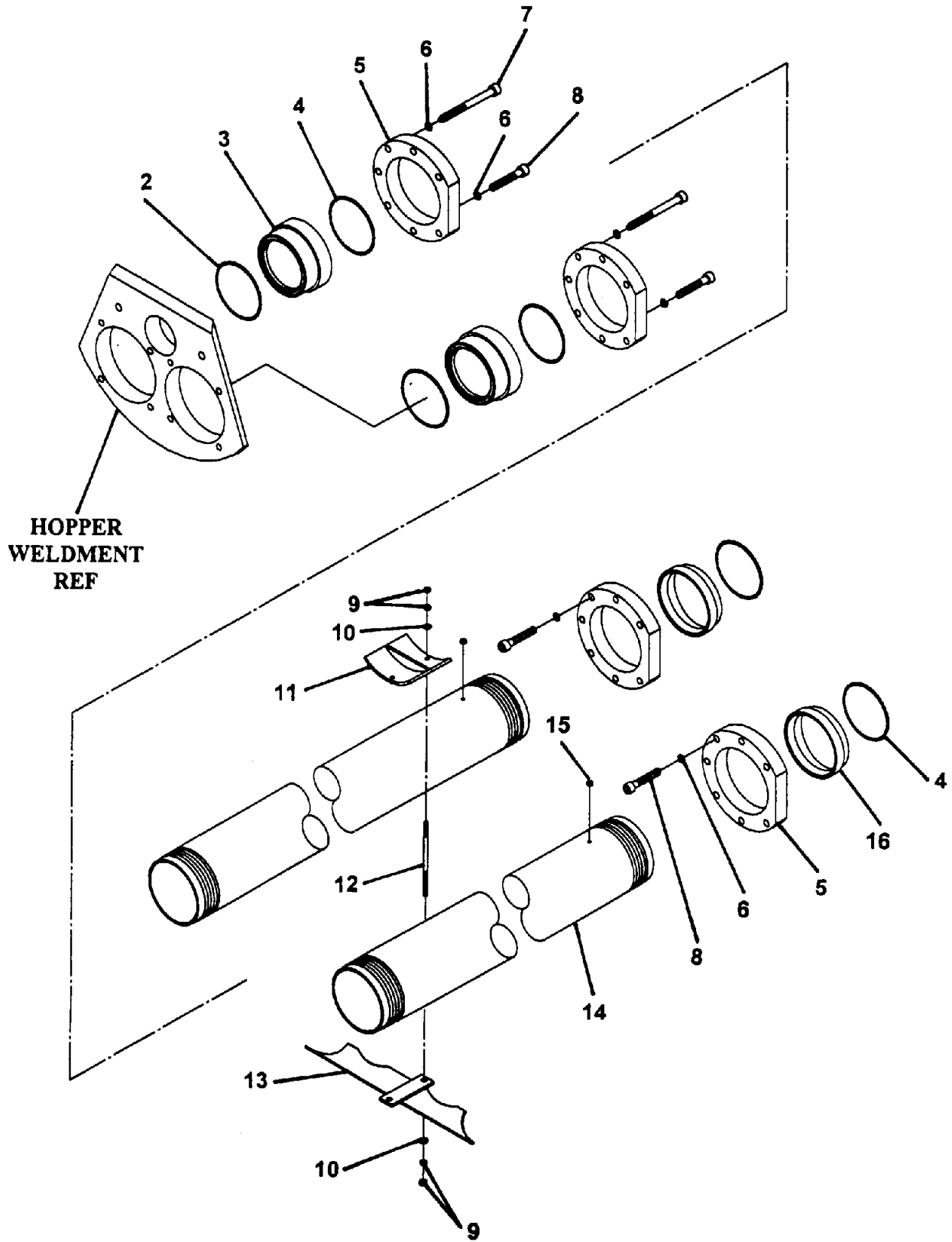

REVISION:

**REED**CONCRETE PLACING  
EQUIPMENT**CONCRETE CYLINDER ASSEMBLY****PARTS**

GROUP 60

FIGURE 04

PAGE 02

ITEM NO.	REED'S PARTS NO.	DESCRIPTION					QTY
		1	2	3	4	5	
-1	B-124013	Assembly, Concrete Cylinder (See Group 60, Figure 01 for NHA)					Ref
2	W-101090	• O-Ring, 230 x 5					2
3	B-124007	• Ring, Fitting DN230					2
4	W-100480	• O-Ring, 240.67 x 6.99					4
5	B-123007	• Flange					4
6	W-100691	• Washer					28
7	W-102844	• Bolt, M20 x 140					6
8	W-103970	• Screw, M20 x 120					14
9		• Nut					8
10		• Washer					4
11		• Support, Top					1
12		• Rod, Tie					2
13		• Support, Bottom					1
14	B-123011	• Cylinder, Concrete					2
15		• Fitting, Grease					2
16	B-123012	• Ring, Fitting DN230					2

DASH (-) ITEM NOT ILLUSTRATED

REVISION:

**REED**

CONCRETE PLACING  
EQUIPMENT

# WATER BOX ASSEMBLY

PARTS  
GROUP 60  
FIGURE 05  
PAGE 01

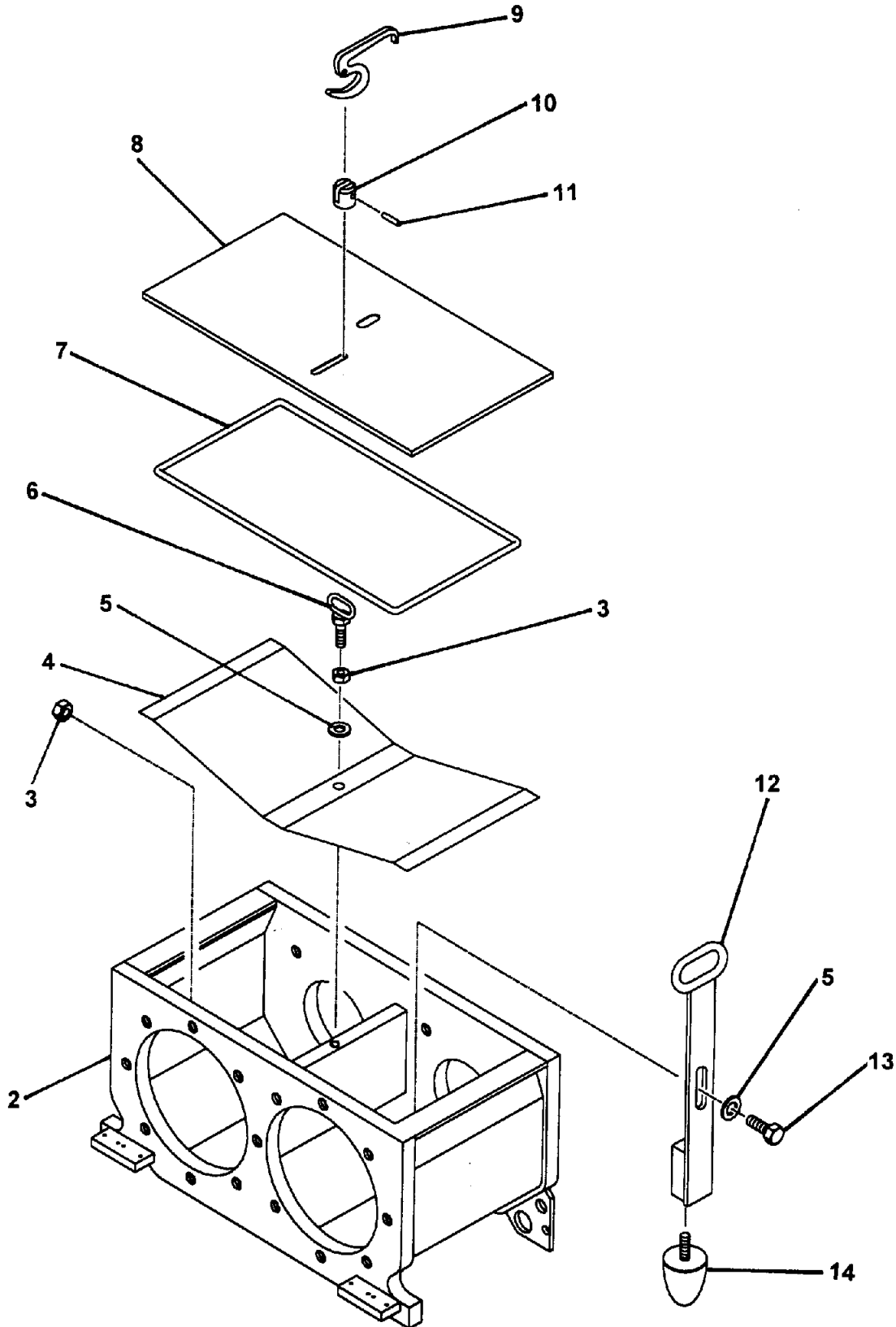

REVISION:





# WATER BOX ASSEMBLY

**PARTS**  
**GROUP 60**  
**FIGURE 05**  
**PAGE 02**

ITEM NO.	REED'S PARTS NO.	DESCRIPTION	QTY
		1 2 3 4 5	
-1	B-143000	Assembly, Water Box (See Group 60, Figure 01 for NHA)	Ref
2	B-143001	• Weldment, Water Box	1
3	W-101557	• Nut, Hex M12	2
4	B-143020	• Grid, Water Box	1
5	W-100504	• Washer, A13	2
6	B-143009	• Bolt, Eye M12	1
7	W-101831	• O-Ring, Round Cord	1
8	B-143015	• Cover, Water Box	1
9	B-143007	• Lever	1
10		• Head, Eye Bolt	1
11	W-103387	• Pin, Grooved 10 x 30	1
12	B-143011	• Handle	1
13	W-101560	• Bolt, Hex M12 x 50	1
14	W-103034	• Buffer, Rubber	1

DASH (-) ITEM NOT ILLUSTRATED

*24 SFYO flange*  
*O-RING - 2 1/8 O.D*  
*1/8 THK*  
*1 1/2*  
*1/16 O.D*

**REED**

CONCRETE PLACING  
EQUIPMENT

# HYDRAULIC DRIVE CYLINDER ASSEMBLY

**PARTS**  
GROUP 60  
FIGURE 06  
PAGE 01

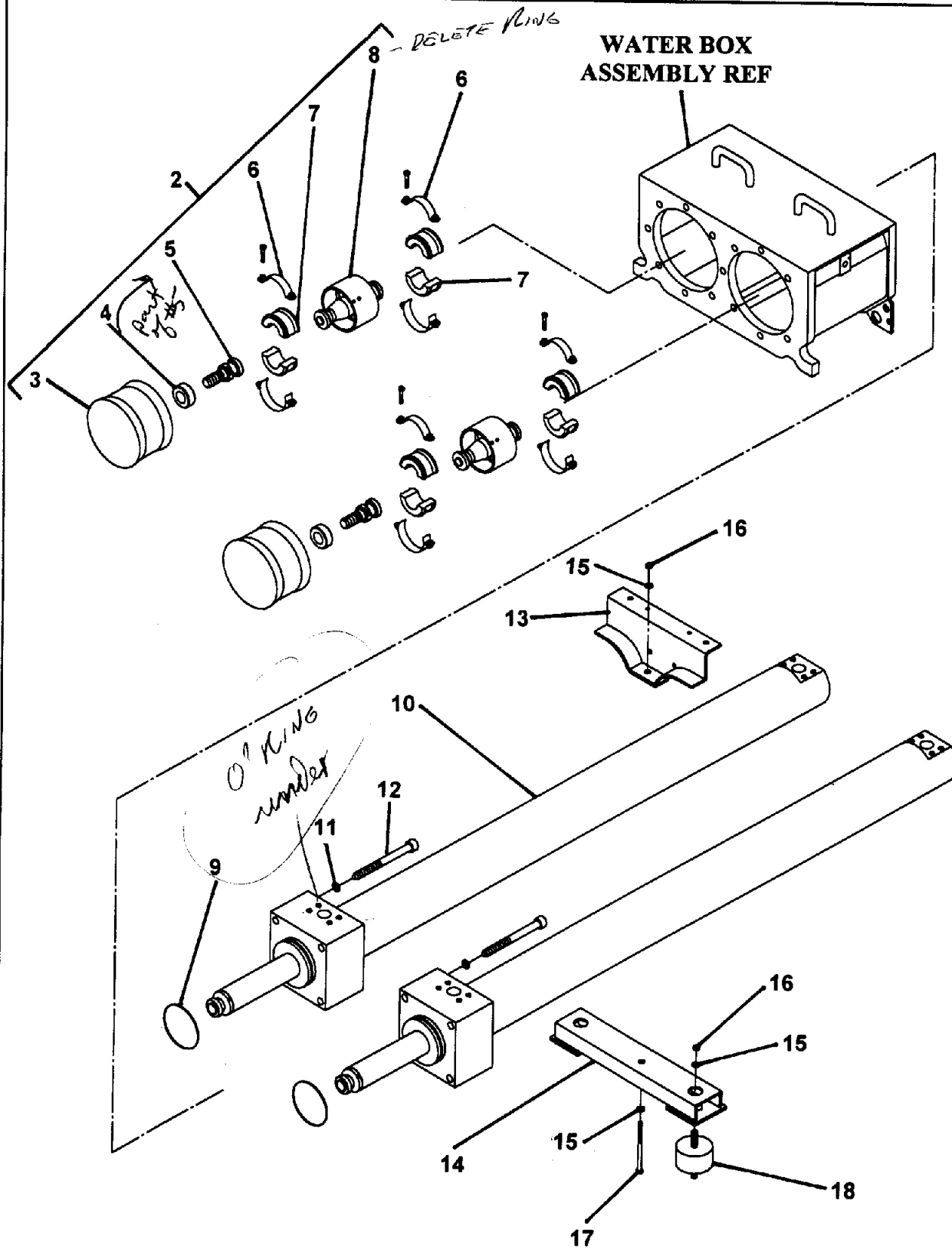

REVISION:







# HYDRAULIC DRIVE CYLINDER ASSEMBLY

**PARTS  
GROUP 60  
FIGURE 06  
PAGE 02**

ITEM NO.	REED'S PARTS NO.	DESCRIPTION					QTY
		1	2	3	4	5	
-1	60-06	Assembly, Hydraulic Drive Cylinder (See Group 60, Figure 01 for NHA)					Ref
2	B-133011	• Assembly, Piston Ram					1
3	W-100175	• • Ram, Piston					2
4	<del>W-100934</del>	<del>• • Ring, Fitting</del>					2
5	<del>B-131003</del>	• • Pin, Coupling <i>B133018 -</i>					2
6	W-101381	• • Clamp, Hose					4
7	B-131004	• • Coupling, Clamp					4
8	B-133003	• • Spacer <i>RING USED ON UNITS W/ PROX SW IN CYL</i>					2
9	<i>W-100190</i>	• O-Ring					
10	B-153001	• Sub-Assembly, Hydraulic Drive Cylinder (See Group 60, Figure 07 for DET)					2
11	W-103070	• Washer (attaching parts)					6
12	W-102846	• Bolt (attaching parts)					6
13		• Support, Upper					1
14		• Support, Bottom					1
15		• Washer (attaching parts)					4
16		• Nut (attaching parts)					3
17		• Bolt (attaching parts)					1
18		• Fitting					2

DASH (-) ITEM NOT ILLUSTRATED

*B133005 ADAPTOR W/ RING USED FOR PROX SW IN WATER BOX*

**HYDRAULIC DRIVE  
CYLINDER SUB-ASSEMBLY**

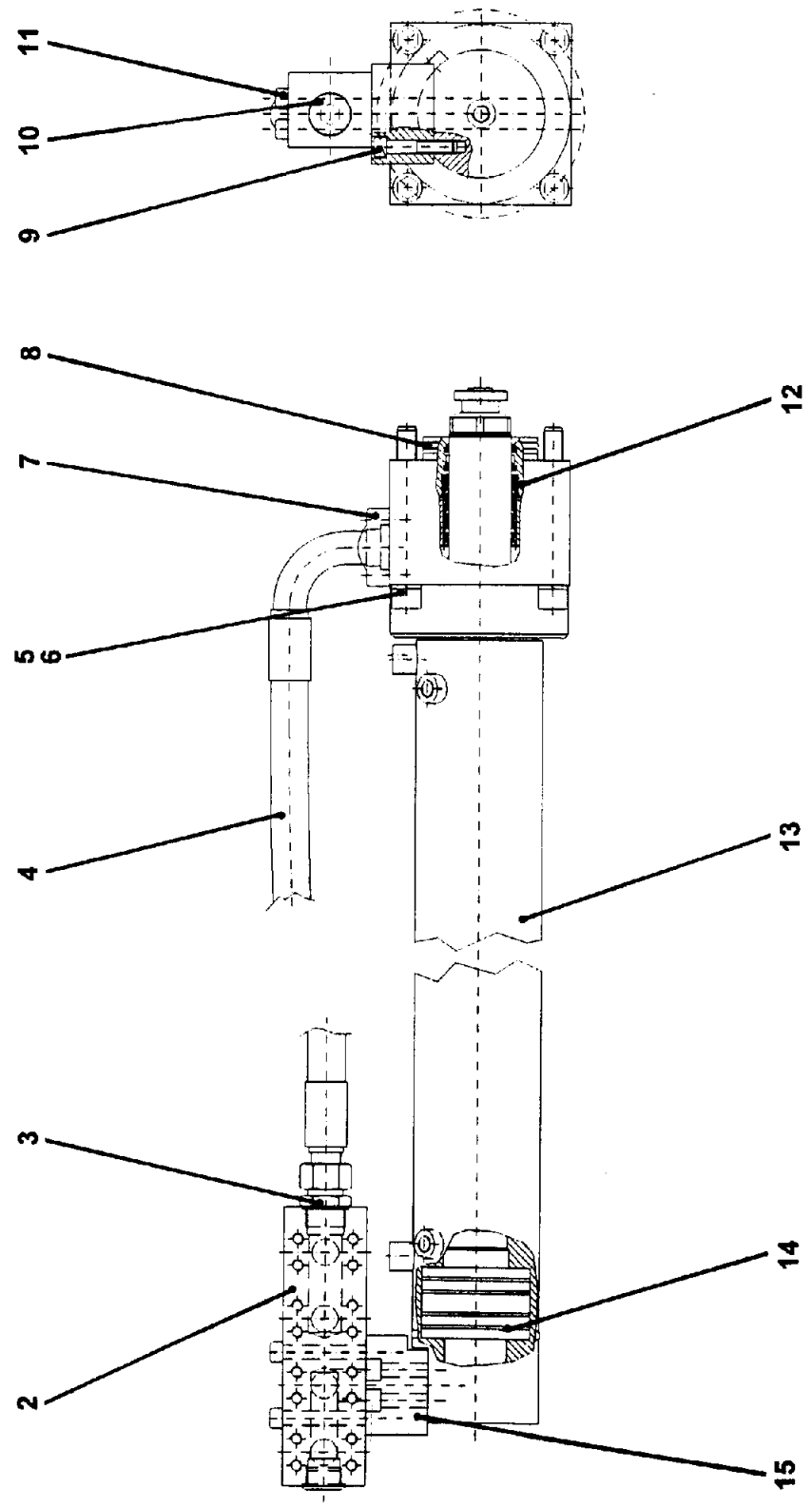

REVISION:

**REED**CONCRETE PLACING  
EQUIPMENT**HYDRAULIC DRIVE  
CYLINDER SUB-ASSEMBLY****PARTS  
GROUP 60  
FIGURE 07  
PAGE 02**

ITEM NO.	REED'S PARTS NO.	DESCRIPTION	QTY
		1 2 3 4 5	
-1	B-153001	Sub-Assembly, Hydraulic Drive Cylinder (See Group 60, Figure 06 for NHA)	Ref
2	B-153002	• Box, Hydraulic	1
3	W-102184	• Coupling, Straight Male Stud	1
4		• Assembly, High Pressure Hose	1
5	W-102846	• Screw, M24 x 190	4
6	W-103070	• Washer, Spring	4
7	W-102305	• Flange (set)	1
8	W-100190	• O-Ring	1
9		• Screw, M16 x 80	4
10	W-103347	• Screw, Locking R 1 1/4	1
11		• Screw, M16 x 125	4
12	W-102393	• Set, Seal	1
13	W-102493	• Cylinder, Drive	1
14	W-102759	• Ring, Piston	4
15	B-153003	• Block, Hydraulic	1

DASH (-) ITEM NOT ILLUSTRATED

REVISION:

# REED

CONCRETE PLACING  
EQUIPMENT

## CENTRAL LUBRICATION SYSTEM

PARTS

GROUP 60

FIGURE 08

PAGE 01

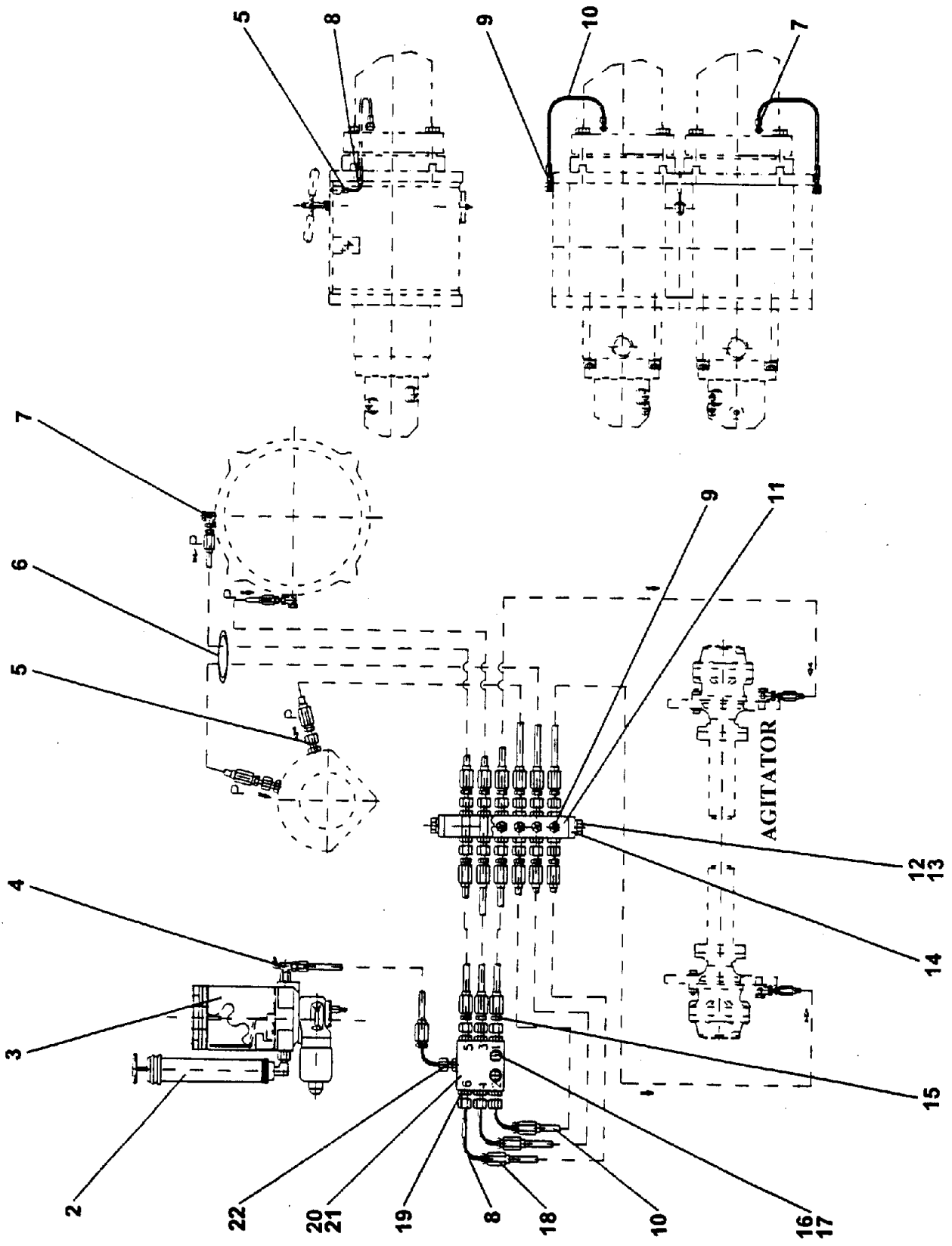

REVISION:



**REED**CONCRETE PLACING  
EQUIPMENT**CENTRAL LUBRICATION SYSTEM****PARTS  
GROUP 60  
FIGURE 08  
PAGE 02**

ITEM NO.	REED'S PARTS NO.	DESCRIPTION	QTY
		1 2 3 4 5	
-1	B-184000	System, Central Lubrication (See Group 60, Figure 01 for NHA)	Ref
2	W-100297	• Pump, Fill (Hand Used)	1
3	800065	• Assembly, Lubrication Pump (See Group 80, Figure 03 for REF)	1
4	W-103198	• Valve, R 1/4 Safety	1
5	W-100546	• Coupling, L6M Straight Mail Stud M10 x 1	16
6	W-103107	• Tie, Cable	30
7	W-102884	• Elbow, L6M throttle Free benjo	6
8	W-102643	• Sleeve, 90 Threaded	30
9	W-100303	• Nipple, Grease M10 x 1	8
10	W-100255	• Pipe, Plastic (15m)	1
11	B-184001	• Strip, Lubrication	1
12	W-102873	• Screw, M8 x 16	2
13	W-102205	• Washer, A8 Spring	2
14	B-184002	• Plate, Lubrication Mechanism	2
15	W-100253	• Piece, Hose Connection	24
16	W-103847	• Screw, Hex M6 x 40	2
17	W-103000	• Washer, A6 Spring	2
18	W-100254	• Sleeve, Threaded	30
19	W100299	• Valve, DN6 Pipe Stroke	6
20	W-100298	• Distributor, SSV 6-K	1
21	B-184003	• Plate, Lubrication Distributor Tap	1
22	W-100302	• Coupling, Straight Male Stud	1

DASH (-) ITEM NOT ILLUSTRATED

REVISION:

**VALVES INSTALLATION**

72803

AUX # DUMP VALVE & CART,  
NOT SHOWN #800087

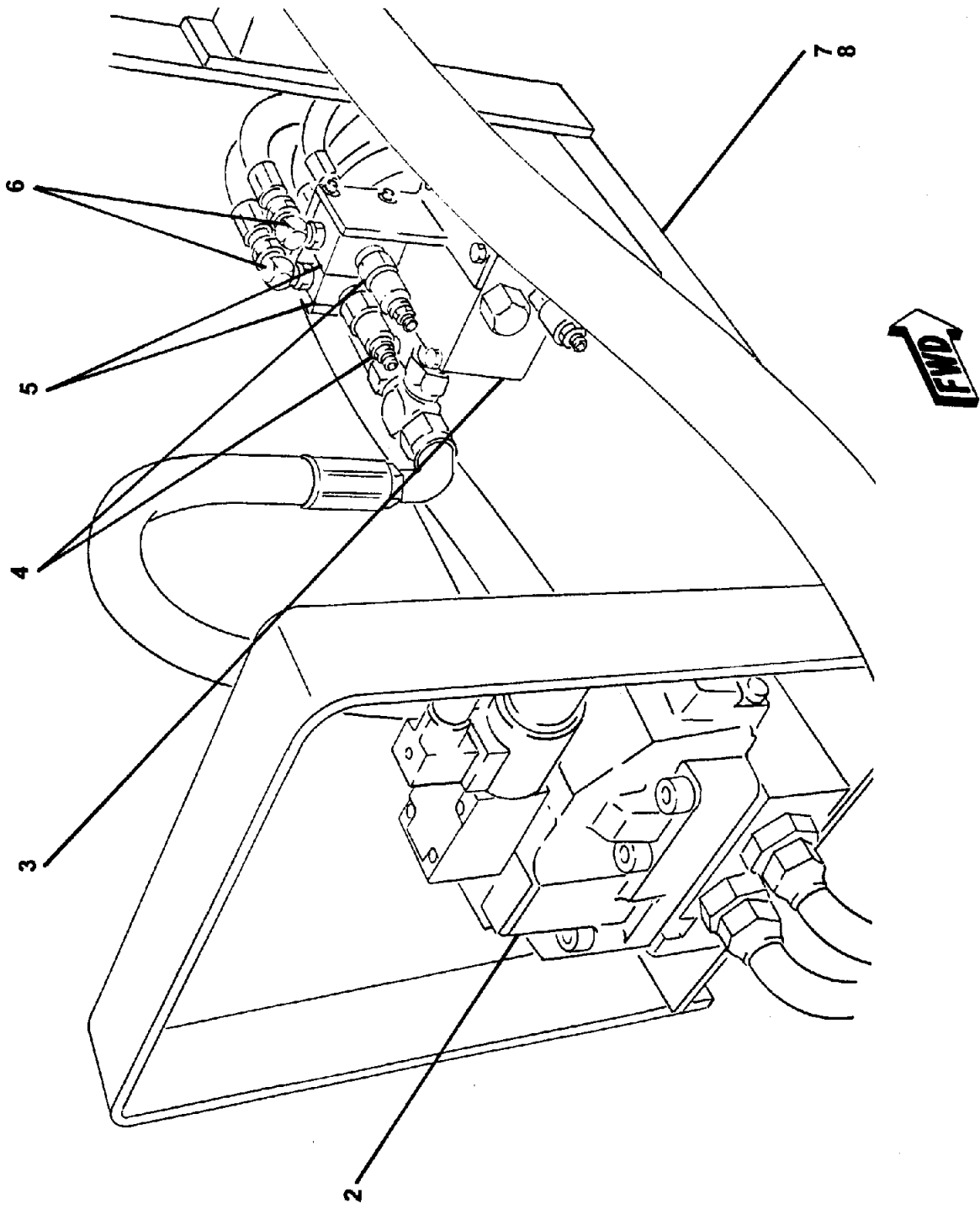

REVISION:

**VALVES INSTALLATION**

ITEM NO.	REED'S PARTS NO.	DESCRIPTION	QTY
		1 2 3 4 5	
-1	60-09	Installation, Valve (See Group 60, Figure 01 for NHA)	Ref
2	60-10	• Assembly, Swing Circuit Cylinder Valve (See Group 60, Figure 10 for DET)	1
3	60-12	• Assembly, Un-loader Manifold (See Group 60, Figure 12 for DET)	1
4	800074	• Limiter, Remote Pressure	2
5	800073	• Adapter, Remote Pressure	2
6		• Fitting, 90	2
7	800024	• Mount, Shift Valves	2
8	800023	• Cover, Shift Valves	1

DASH (-) ITEM NOT ILLUSTRATED

**REED**

CONCRETE PLACING  
EQUIPMENT

**SWING CIRCUIT CYLINDER  
VALVE ASSEMBLY**

**PARTS  
GROUP 60  
FIGURE 10  
PAGE 01**

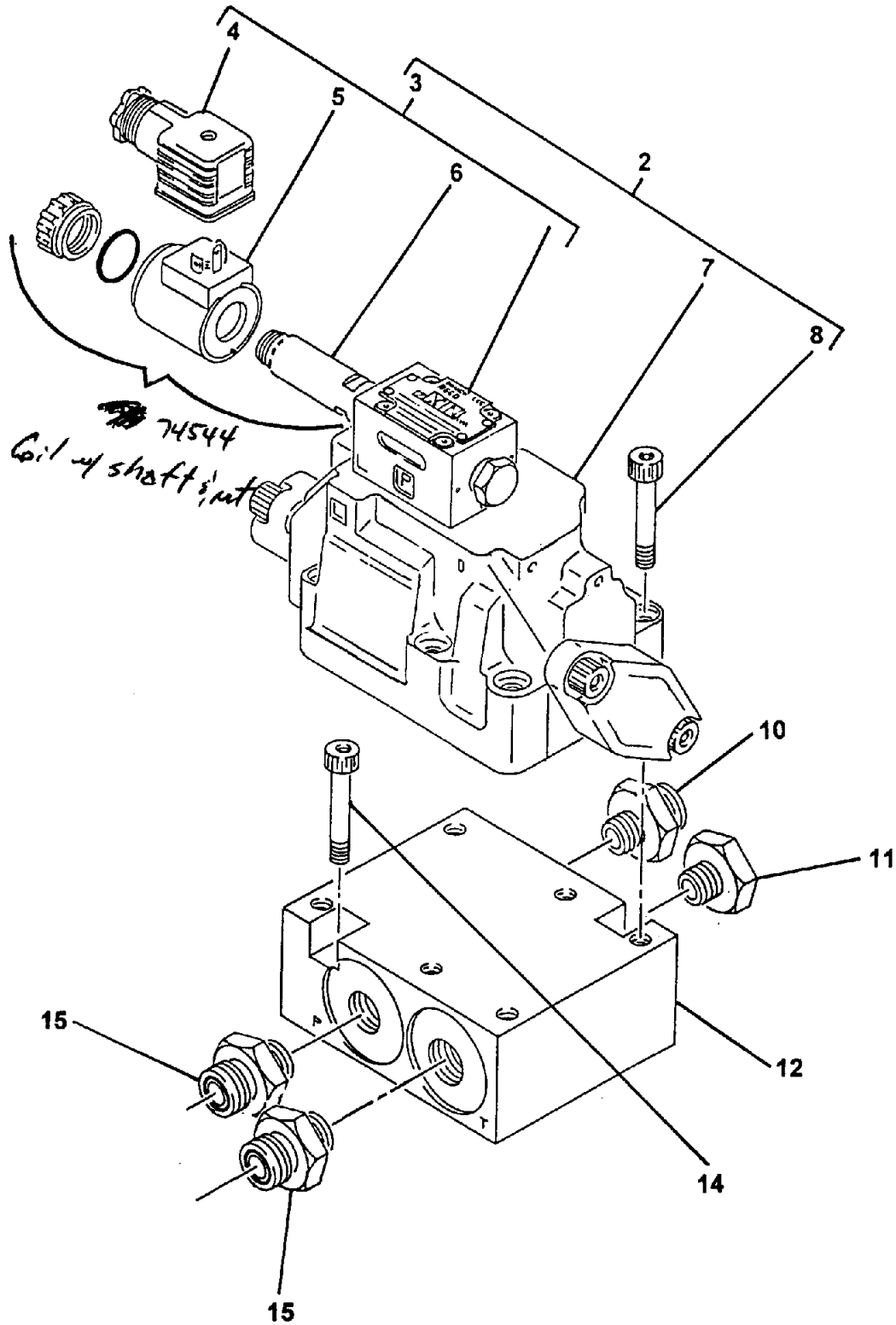

REVISION:



# SWING CIRCUIT CYLINDER VALVE ASSEMBLY

**PARTS  
GROUP 60  
FIGURE 10  
PAGE 02**

ITEM NO.	REED'S PARTS NO.	DESCRIPTION	QTY
		1 2 3 4 5	
-1	60-10	Assembly, Swing Circuit Cylinder (See Group 60, Figure 09 for NHA)	Ref
2	74991	• Valve, Swing Circuit Cycling	1
3	74517	•• Sub - Assembly, Solenoid	1
4	74597	••• Connector, Plug	1
5	85692	••• Coil, Solenoid	1
6		••• Armature	1
7	74935	•• Sub-Assembly, Directional Control Valve Main Body (See Group 60, Figure 11 for DET)	1
8		•• Screw, 1/2 - 13 x 2 1/4	6
-9	74994	•• Kit, Seal	1
10		• Fitting, STR	1
11		• Reducer	1
12	75161	• Sub - Plate	1
-13		•• Kit, Seal	1
14		• Screw, 1/2 - 13 x 2 1/2	2
15		• Fitting, STR	2

DASH (-) ITEM NOT ILLUSTRATED

REVISION:

**DIRECTIONAL CONTROL  
 VALVE SUB-ASSEMBLY**

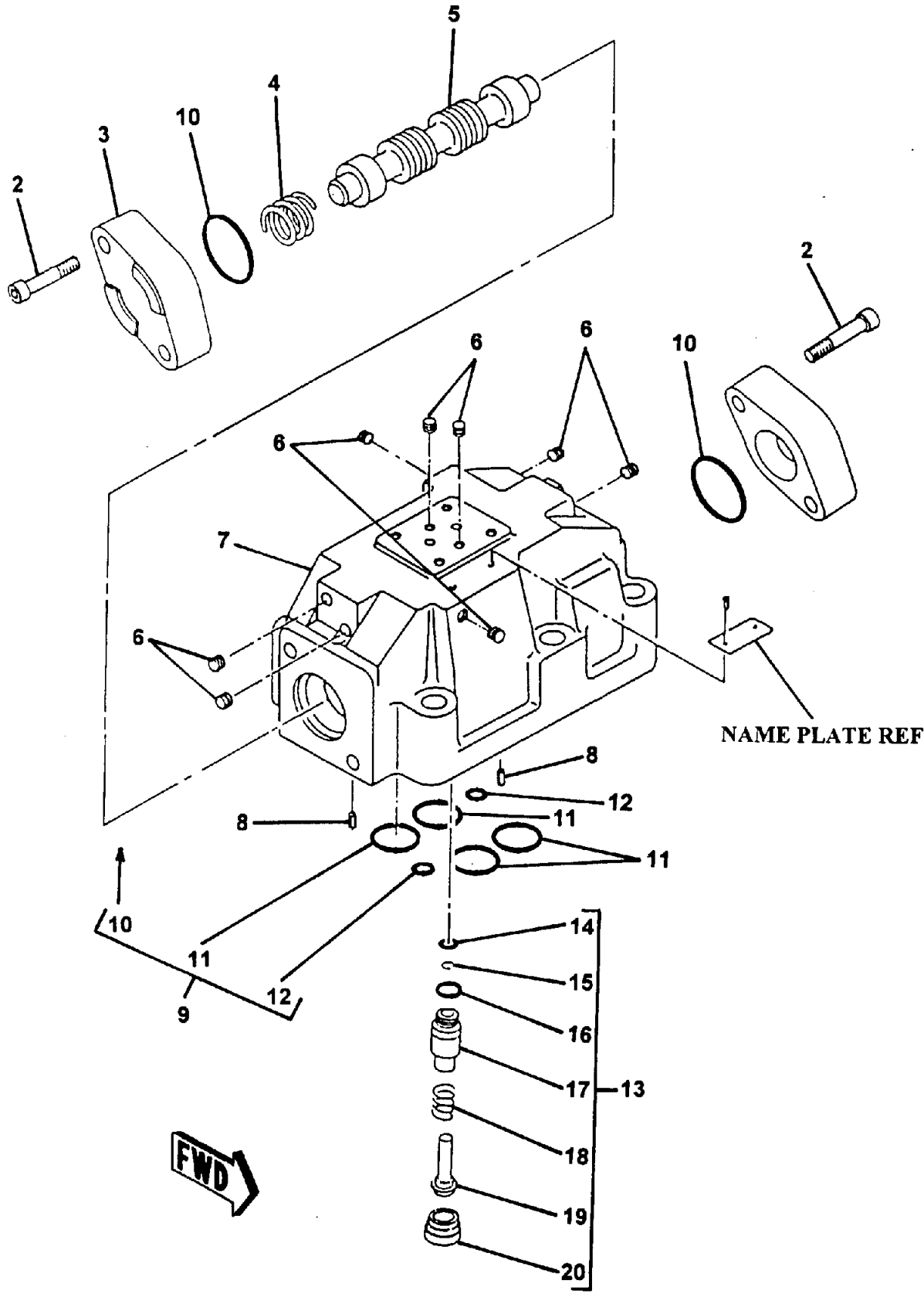

**REED**CONCRETE PLACING  
EQUIPMENT**DIRECTIONAL CONTROL  
VALVE SUB-ASSEMBLY****PARTS  
GROUP 60  
FIGURE 11  
PAGE 02**

ITEM NO.	REED'S PARTS NO.	DESCRIPTION	QTY
		1 2 3 4 5	
-1	74935	Sub-Assembly, Directional Control Valve (See Group 60, Figure 10 for NHA)	Ref
2		• Screw, SOC M10 x 40	1
3		• Cover	1
4		• Spring, Compression	1
5		• Spool	6
6		• Plug M6	4
7		• Housing, Cartridge	2
8		• Pin, Grooved	1
9		• Kit, Seal	1
10		• • O-Ring, 42 x 3	1
11		• • O-Ring, 27 x 3	1
12		• • O-Ring, 19 x 3	1
13	73147	• Sub-Assembly, Pilot Pressure Valve	2
14		• • O-Ring, 12 x 1.5	1
15		• • Circlip, A8	1
16		• • O-Ring	1
17		• • Sleeve	1
18		• • Spring, Compression	1
19		• • Cone	1
20		• • Valve, Seat	1

DASH (-) ITEM NOT ILLUSTRATED

REVISION:

**REED**

CONCRETE PLACING  
EQUIPMENT

**UNLOADER MANIFOLD SYSTEM**

**PARTS**

GROUP 60

FIGURE 12

PAGE 01

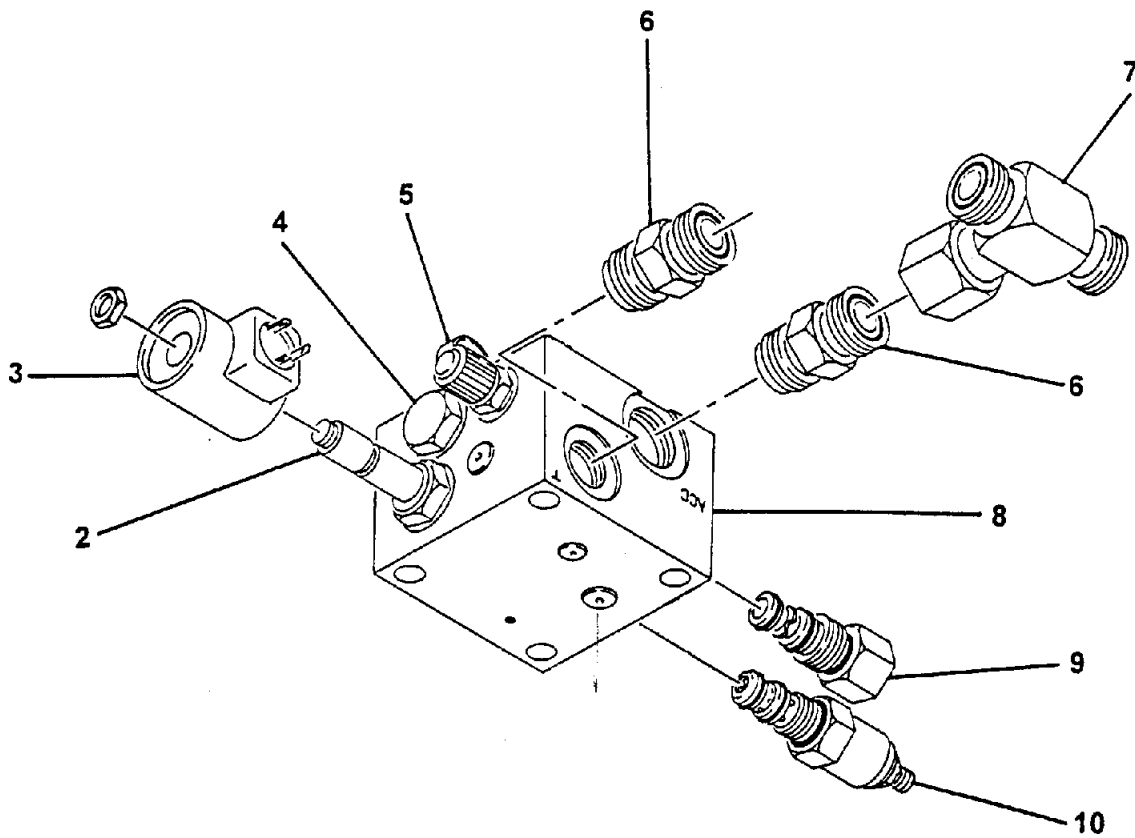

REVISION:



**REED**CONCRETE PLACING  
EQUIPMENT**UNLOADER MANIFOLD SYSTEM****PARTS**

GROUP 60

FIGURE 12

PAGE 02

ITEM NO.	REED'S PARTS NO.	DESCRIPTION	QTY
		1 2 3 4 5	
-1	60-12	Assembly, Unloader Manifold (See Group 60, Figure 09 for NHA)	Ref
2	73143	• Cartridge, Solenoid Valve	1
3	73184	• • Coil, 12VDC	1
4	73140	• Cartridge, Check Valve	1
5	78593	• Fitting, Mini Check (Port)	1
6		• Fitting, STR FS6400-12-10	1
7		• Tee, FF6600-12-12-12	1
8	72803	• Manifold, Unloader	1
9	73203	• Valve, Directional Control	1
10	73155	• Cartridge, Unloader	1

DASH (-) ITEM NOT ILLUSTRATED

REVISION:

**REED**

CONCRETE PLACING  
EQUIPMENT

**PARTS MANUAL**

**PARTS**

**GROUP 60**

**FIGURE 13**

**PAGE 01**

THIS PAGE INTENTIONALLY LEFT BLANK.

REVISION:

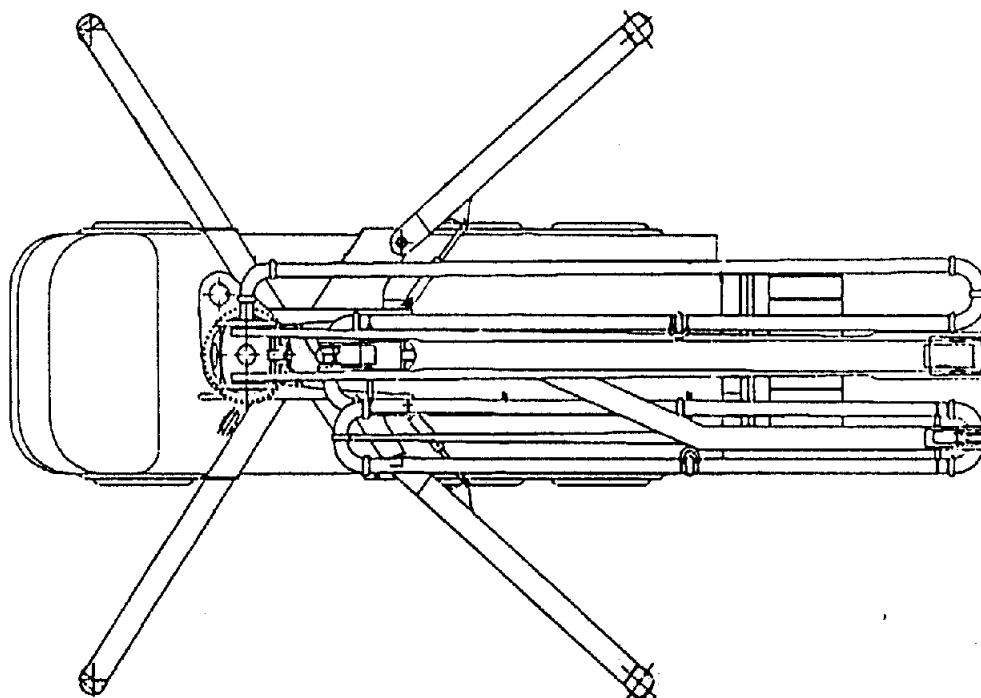
**GROUP 70 FRAME AND  
SUPPORT INSTALLATION**

**GROUP 70 FRAME AND SUPPORT INSTALLATION CONTAINS THE FOLLOWING FIGURES:**

<b>FIGURE 00</b>	<b>TABLE OF CONTENTS</b>
<b>FIGURE 01</b>	<b>FRAME AND SUPPORT INSTALLATION</b>
<b>FIGURE 02</b>	<b>ROTATING HEAD ASSEMBLY</b>
<b>FIGURE 03</b>	<b>MOTOR AND REDUCTION ASSEMBLY</b>
<b>FIGURE 04</b>	<b>ROTATION SUPPORT ASSEMBLY</b>
<b>FIGURE 05</b>	<b>SUPPORT FRAME STABILIZERS ASSEMBLY</b>
<b>FIGURE 06</b>	<b>FRONT STABILIZERS HORIZONTAL JACKS ASSEMBLY</b>
<b>FIGURE 07</b>	<b>FRONT RIGHT STABILIZER JACK ASSEMBLY</b>
<b>FIGURE 08</b>	<b>FRONT LEFT AND REAR STABILIZER JACKS ASSEMBLY</b>
<b>FIGURE 09</b>	<b>REAR STABILIZERS HORIZONTAL JACKS ASSEMBLY</b>

**FRAME AND SUPPORT INSTALLATION**

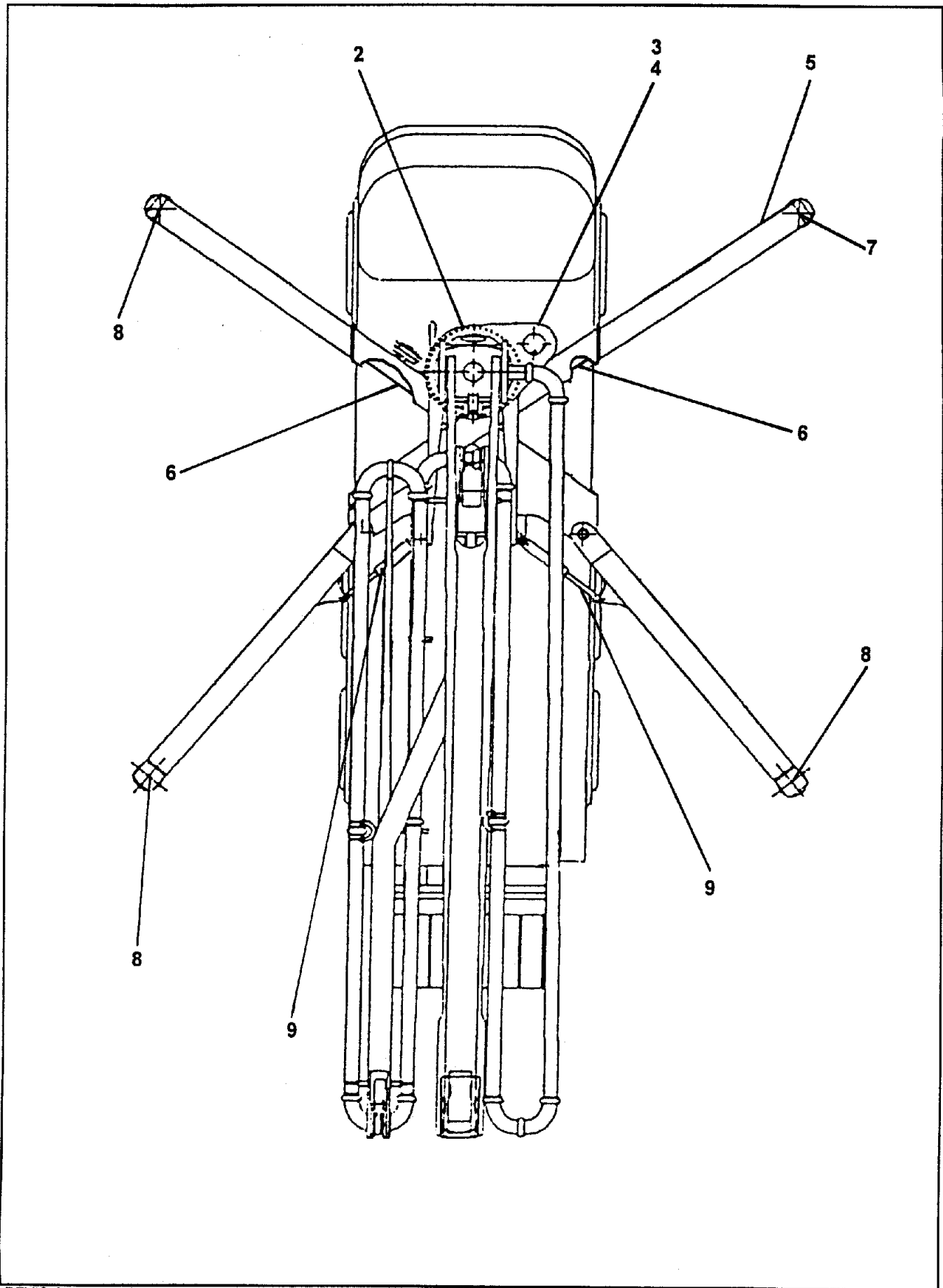

**REED**CONCRETE PLACING  
EQUIPMENT**FRAME AND SUPPORT INSTALLATION****PARTS  
GROUP 70  
FIGURE 01  
PAGE 02**

ITEM NO.	REED 'S PARTS NO.	DESCRIPTION					QTY
		1	2	3	4	5	
-1	70-01	Installation, Frame And Support (See Group 10, Figure 01 for NHA)					Ref
2	C-3F1	• Assembly, Rotating Head (See Group 70, Figure 02 for DET)					1
3	C-3G1	• Assembly, Motor And Reduction (See Group 70, Figure 03 for DET)					1
4	C-3G2	• Assembly, Rotation Support (See Group 70, Figure 04 for DET)					1
5	C-3H1	• Assembly, Support Frame Stabilizers (See Group 70, Figure 05 for DET)					1
6	C-4K4	• Assembly, Front Stabilizers Horizontal Jack (See Group 70, Figure 06 for DET)					2
7	C-3K5	• Assembly, Front Right Stabilizer Jack (See Group 70, Figure 07 for DET)					1
8	C-3L5	• Assembly, Front Left And Rear Stabilizer Jacks (See Group 70, Figure 08 for DET)					3
9	C-3M3	• Assembly, Rear Stabilizers Horizontal Jack (See Group 70, Figure 09 for DET)					2

DASH (-) ITEM NOT ILLUSTRATED

REVISION:

# REED

CONCRETE PLACING  
EQUIPMENT

## ROTATING HEAD ASSEMBLY

PARTS  
GROUP 70  
FIGURE 02  
PAGE 01

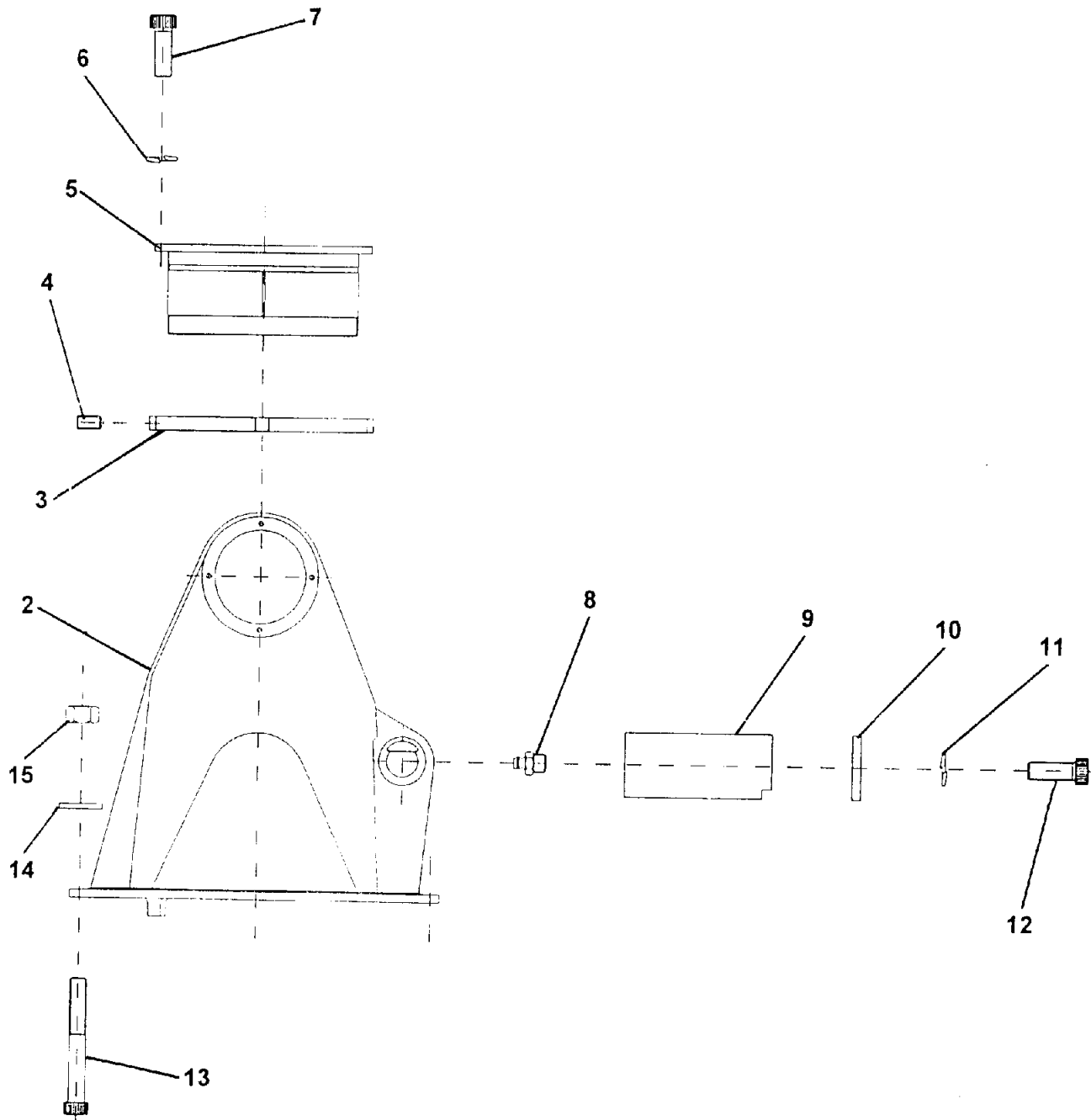
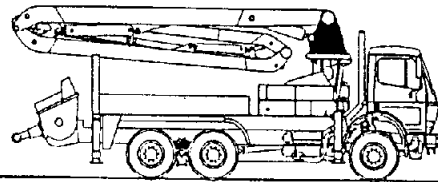
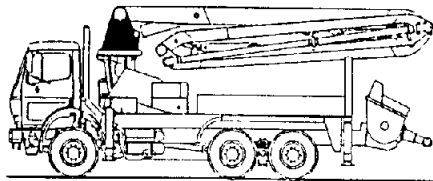

REVISION:

**REED**CONCRETE PLACING  
EQUIPMENT**ROTATING HEAD ASSEMBLY****PARTS**  
GROUP 70  
FIGURE 02  
PAGE 02

ITEM NO.	REED'S PARTS NO.	DESCRIPTION	QTY
		1 2 3 4 5	
-1	C-3F1	Assembly, Rotating Head (See Group 70, Figure 01 for NHA)	Ref
2	C-3F101	• Head, Rotating	1
3	C-GV228.2015	• Ring, Threaded 802039	2
4	C-VG121.061010	• Screw	4
5	C-4P118	• Pin W-106480	2
6	C-UE110.14	• Washer, Elastic	8
7	C-VC111.142040	• Screw	8
8	C-VI110.1010	• Nipple, Grease	1
9	C-3P116A	• Pin	1
10	C-UD080.1111	• Washer, Pin Locking	1
11	C-UE110.10	• Washer, Elastic	1
12	C-VC111.101525	• Screw	1
13	C-VC132.2225C6	• Screw	48
14	C-UP110.22	• Washer	48
15	C-VD131.2225	• Nut	48
-16	C-LG040.040	• Distance Piece, Locking	1

DASH (-) ITEM NOT ILLUSTRATED

REVISION:

# REED

CONCRETE PLACING  
EQUIPMENT

## MOTOR AND REDUCTION ASSEMBLY

PARTS  
GROUP 70  
FIGURE 03  
PAGE 01

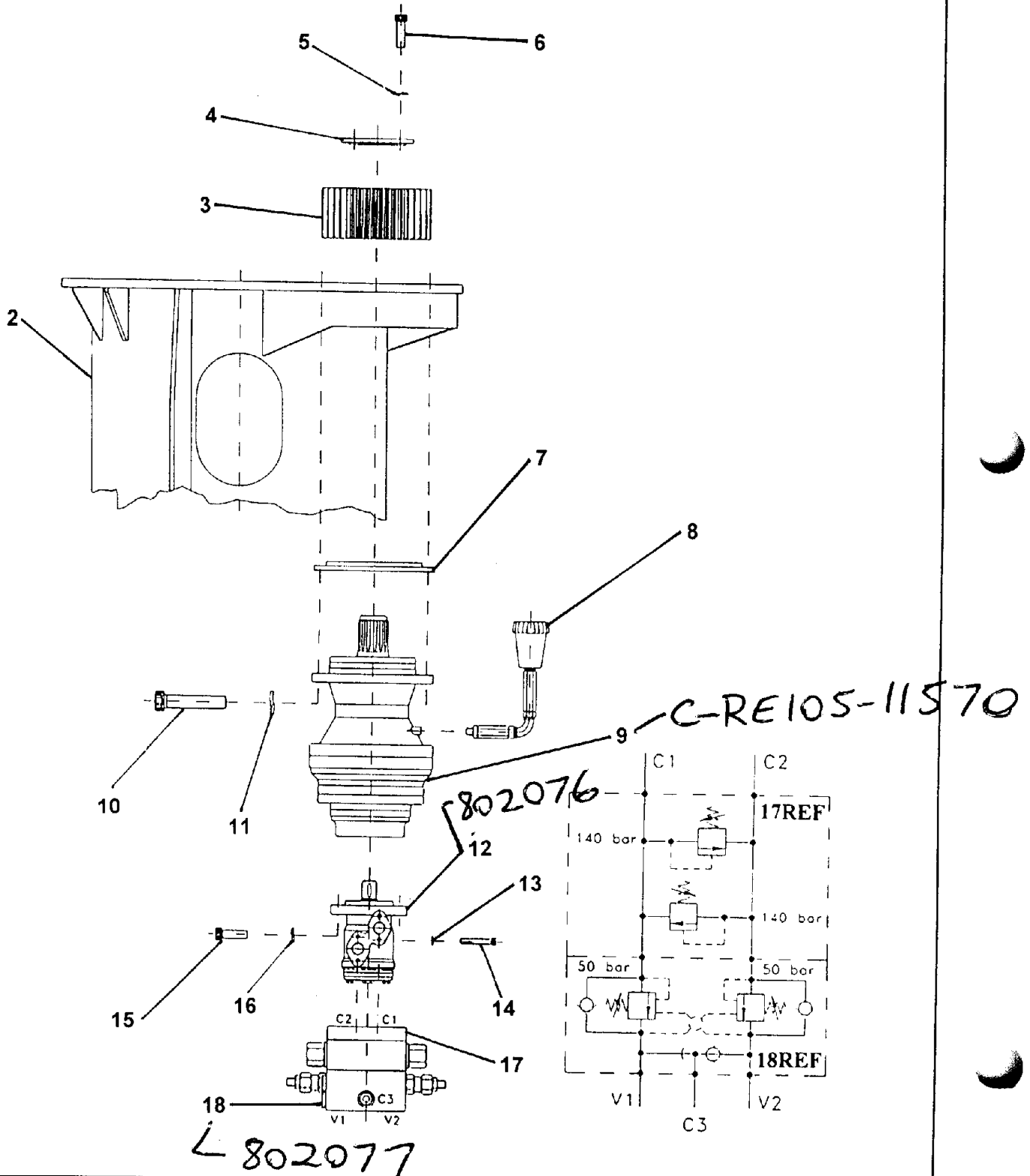
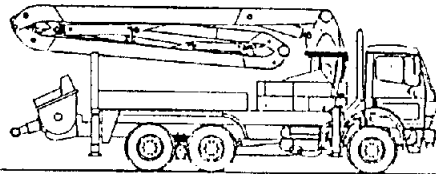
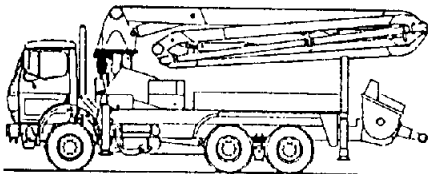

REVISION:



**REED**CONCRETE PLACING  
EQUIPMENT**MOTOR AND REDUCTION ASSEMBLY****PARTS**  
GROUP 70  
FIGURE 03  
PAGE 02

ITEM NO.	REED'S PARTS NO.	DESCRIPTION					QTY
		1	2	3	4	5	
-1	C-3G1	Assembly, Motor And Reduction (See Group 70, Figure 01 for NHA)					Ref
2	C-3H101	• Frame, Support					1
3	C-RP114.120	• Pinion 802074					1
4	C-RP1000	• Washer, Pinion 802078					1
5	C-UE110.10	• Washer, Elastic (attaching parts)					3
6	C-VC111.101530	• Screw (attaching parts)					3
7	C-3G102	• Flange, Adjusting Coupling					1
8	C-LL101	• Level, Oil					1
9	C-RE103.11570	• Unit, Reduction C-RE105-11570					1
10	C-VC112.162060	• Screw (attaching parts)					10
11	C-UE110.16	• Washer, Elastic (attaching parts)					10
12	C-MI110.080	• Assembly, Hydraulic Motor 802076					1
13	C-UE110.00	• Washer, Elastic (attaching parts)					4
14	C-VC110.000000	• Screw (attaching parts)					4
15	C-VC111.000000	• Screw (attaching parts)					2
16	C-UE110.00	• Washer, Elastic (attaching parts)					2
17	C-WA100.050	• Valve, Direct Acting Relief					1
18	C-WB100.160	• Valve, Over Center 802077					1

DASH (-) ITEM NOT ILLUSTRATED

REVISION:

**REED**

CONCRETE PLACING  
EQUIPMENT

**ROTATION SUPPORT ASSEMBLY**

**PARTS  
GROUP 70  
FIGURE 04  
PAGE 01**

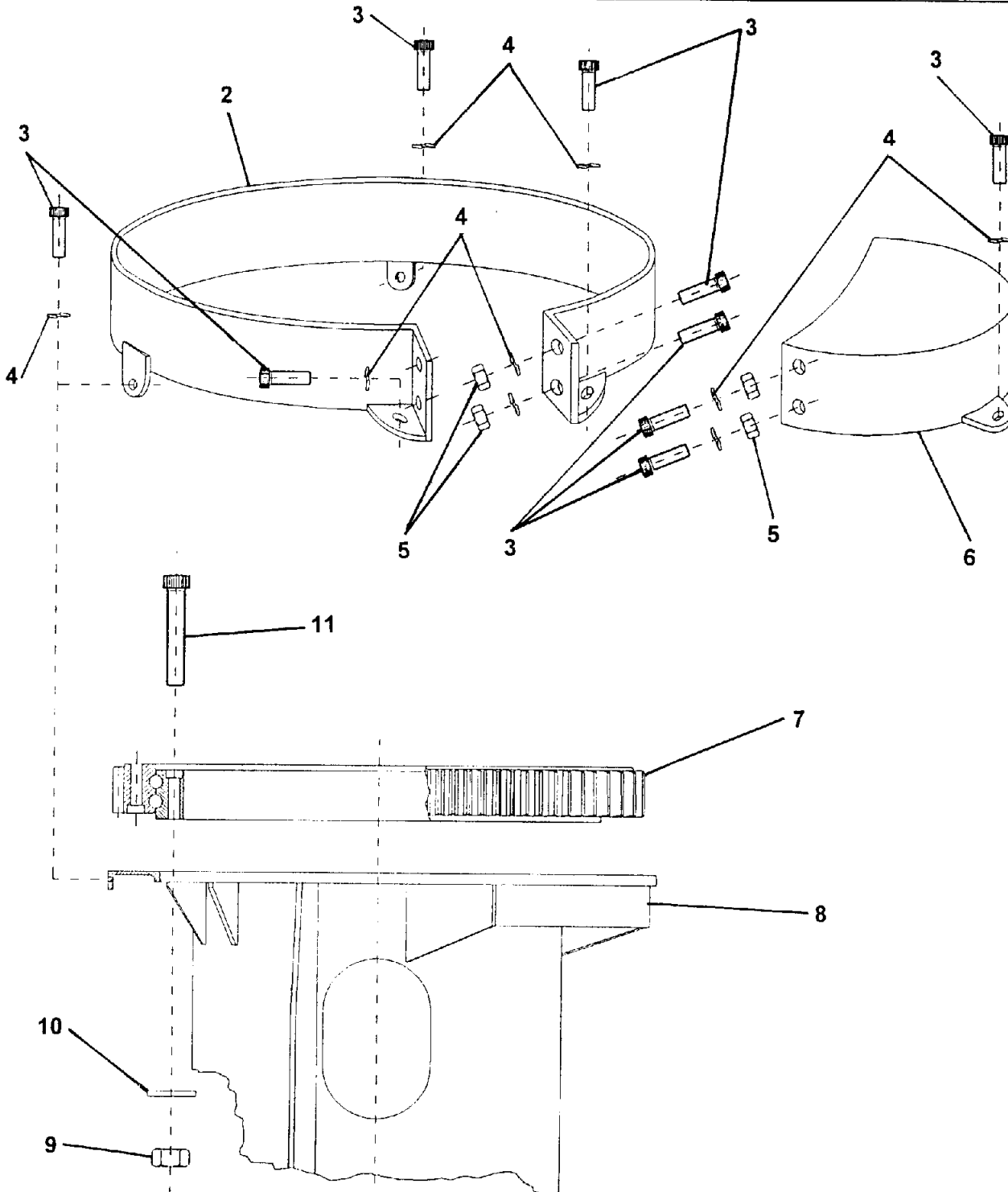
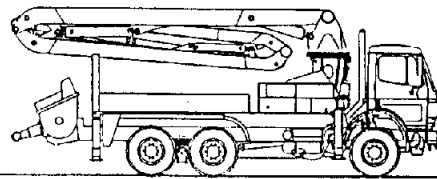
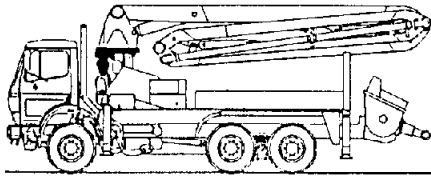

REVISION:

**REED**CONCRETE PLACING  
EQUIPMENT**ROTATION SUPPORT ASSEMBLY****PARTS**

GROUP 70

FIGURE 04

PAGE 02

ITEM NO.	REED'S PARTS NO.	DESCRIPTION	QTY
		1 2 3 4 5	
-1	70-04	Assembly, Non-Operator Side Door (See Group 70, Figure 01 for NHA)	Ref
2	C-3G204	• Protection, Rotating	1
3	C-VC111.081525	• Screw	9
4	C-UE110.08	• Washer, Elastic (attaching parts)	9
5	C-VD111.0815	• Nut	4
6	C-3G203	• Protection, Pinion	4
7	C-B112.116	• Bearing, Rotation	1
8	C-3H101	• Frame, Support	1
9	C-VD131.2225	• Nut (attaching parts)	48
10	C-UP110.22	• Washer (attaching parts)	48
11	C-VC132.2225C6	• Screw (attaching parts)	48

DASH (-) ITEM NOT ILLUSTRATED

REVISION:



**REED**CONCRETE PLACING  
EQUIPMENT**SUPPORT FRAME  
STABILIZERS ASSEMBLY****PARTS  
GROUP 70  
FIGURE 05  
PAGE 02**

ITEM NO.	REED'S PARTS NO.	DESCRIPTION					QTY
		1	2	3	4	5	
-1	C-3H1	Assembly, Support Frame Stabilizers (See Group 70, Figure 01 for NHA)					Ref
2	C-3K201	• Stabilizer, Removable Part					2
3	C-VC112.222550	• Screw					24
4	C-UE110.22	• Ring, Clamping <i>ELASTIC WASHER</i>					24
5	<del>C-AA200.025</del>	• Pin <i>CLAMPING RING W-103000</i>					16
6	C-4P202	• Pin -					4
7	C-4H102	• Roller -					42
8	C-CD025.030050	• Bearing, Antifriction <i>BUSHING-ROLLER</i>					42
9	C-4P201	• Pin, <i>ROLLER</i>					42
10	C-VI110.1010	• Nipple, Grease					6
11	C-3G205	• Washer					2
12	C-3P202	• Pin					1
13	C-VS110.08070	• Pin, Split					2
14	C-3P205	• Pin					4
15	C-VS110.06060	• Pin, Split					4
16	C-3H101	• Structure, Base					1
17	C-4H103	• Washer					8
18	C-3P203	• Pin					4
19	C-VS110.10080	• Pin, Split					8
20	C-3M101	• Stabilizer, Rear Right					1
21	C-3M102	• Stabilizer, Rear Left					1
22	C-GV095.2015	• Ring, Threaded					2
23	C-VG121.061010	• Screw					4
24	C-3P201	• Pin					2
25	C-3M105	• Plate, Embed					2
26	C-UE110.12	• Washer, Elastic (attaching parts)					4
27	C-VC111.121740	• Screw (attaching parts)					4
28	C-RA101	• Roller, Wrapper					2
-29	C-LG040.040	• Distance Piece, Locking					4

- 30 C-5H105 *ROLLER*  
 - 31 C-CD025028025 *BUSHING ROLLER*  
 - 32 C-3P206 *PIN ROLLER*

DASH (-) ITEM NOT ILLUSTRATED

2  
4  
2

802187 *BUSHINGS FOR 7*  
 C-3P201 *OUTRIGGER PIVOT PINS*

REVISION:

**FRONT STABILIZERS  
HORIZONTAL JACKS ASSEMBLY**

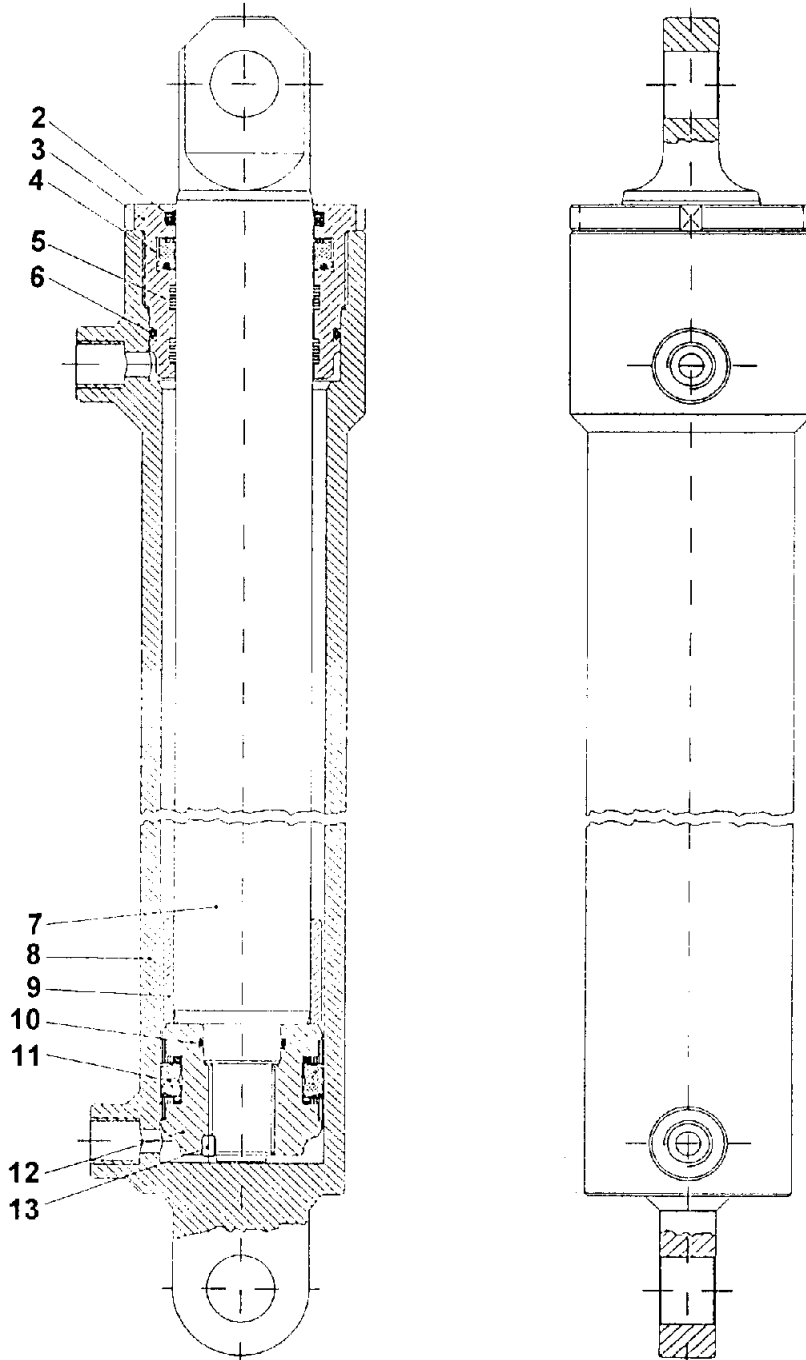
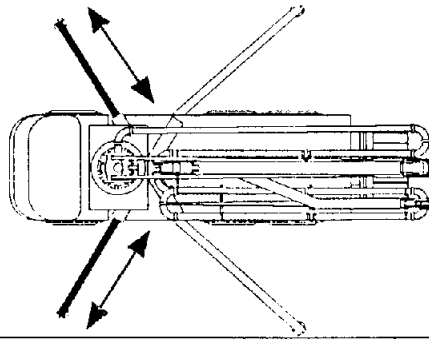

**REED**CONCRETE PLACING  
EQUIPMENT**FRONT STABILIZERS  
HORIZONTAL JACKS ASSEMBLY****PARTS  
GROUP 70  
FIGURE 06  
PAGE 02**

ITEM NO.	REED'S PARTS NO.	DESCRIPTION	QTY
		1 2 3 4 5	
-1	C-4K4	Assembly, Front Stabilizers Horizontal Jacks (See Group 70, Figure 01 for NHA)	Ref
2	C-BR310.050	• Gasket, Seal	1
3	C-4K401	• Head, Slide Rod	1
4	C-BT110.050	• Gasket, Seal	1
5	C-AG122.050	• Ring, Slide Rod	2
6	C-AO120.230	• Ring, Sealing	1
7	C-4K407	• Rod	1
8	C-4K402	• Cylinder	1
9	C-4K424	• Pipe, End Stroke	1
10	C-AO120.121	• Ring, Sealing	1
11	C-BS23236173	• Gasket, Seal	1
12	C-4K412	• Piston	1
13	C-VG121.060008	• Screw	1

DASH (-) ITEM NOT ILLUSTRATED

REVISION:

# REED

CONCRETE PLACING  
EQUIPMENT

## FRONT RIGHT STABILIZER JACK ASSEMBLY

PARTS  
GROUP 70  
FIGURE 07  
PAGE 01

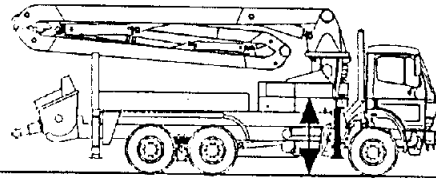
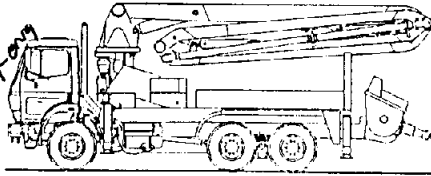

Handwritten note: *holding valve Bore 50 TYPE C-WD100-000*

Handwritten note: *holding valve 4 Bolt T. P/W 802144*

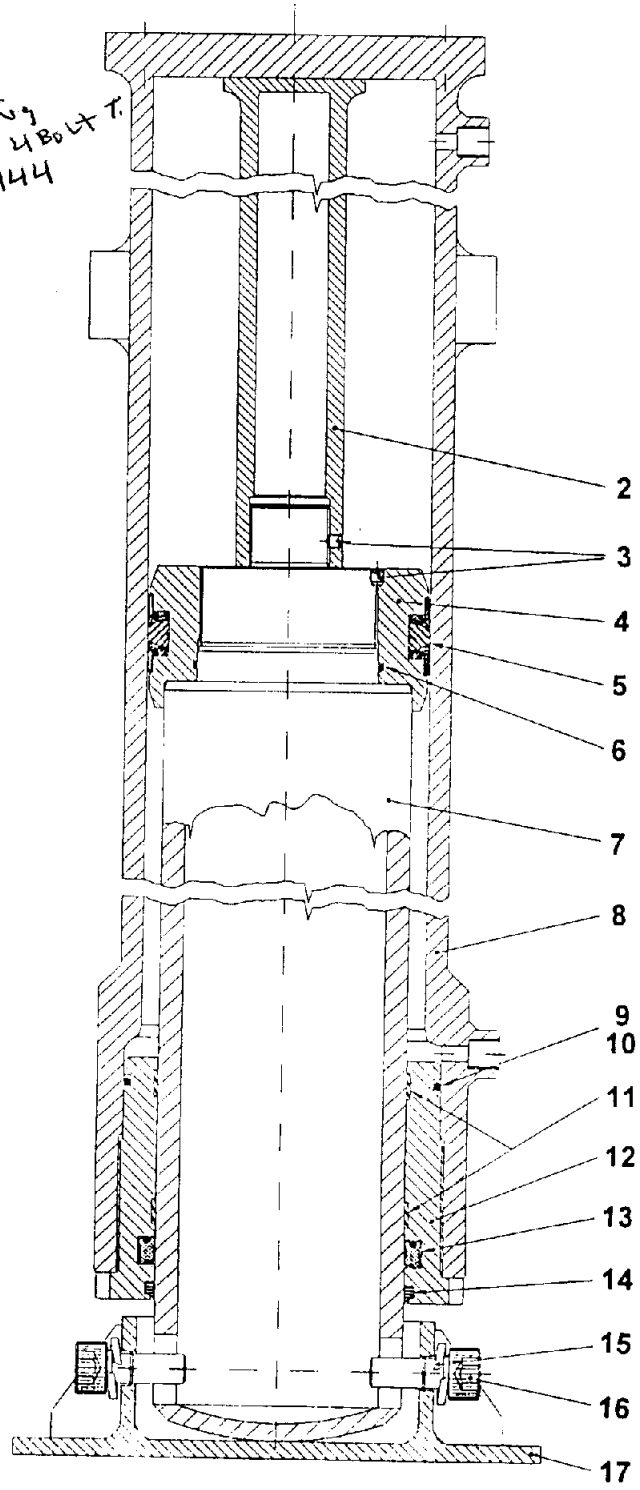
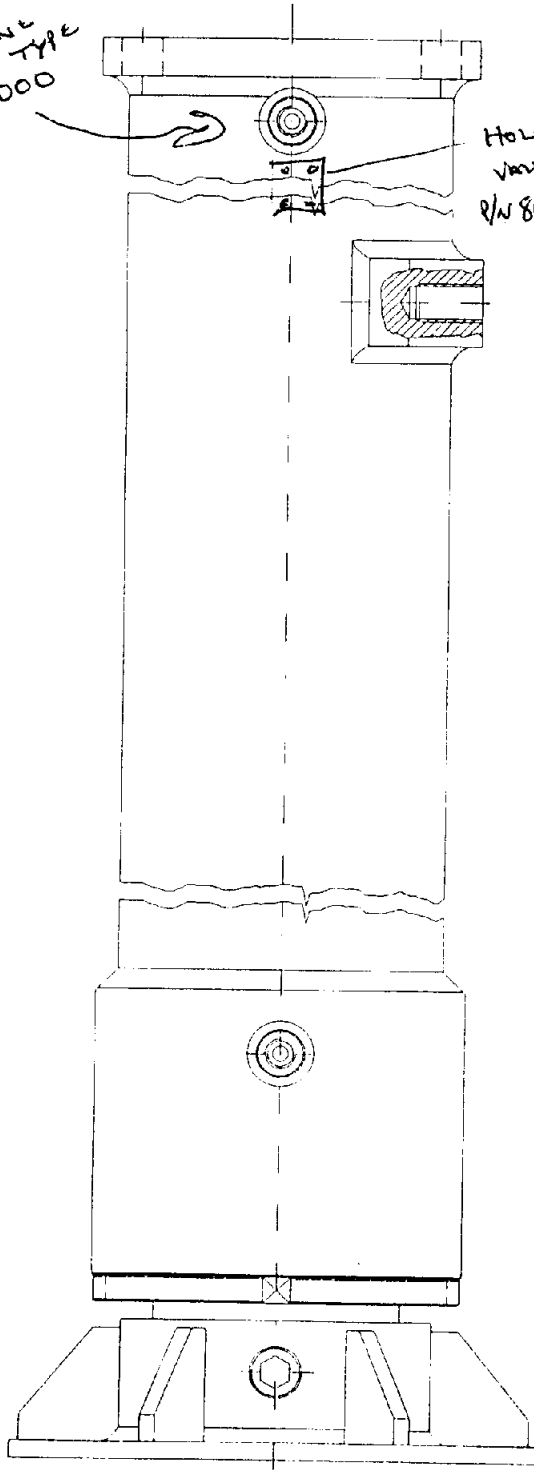

REVISION:



**REED**CONCRETE PLACING  
EQUIPMENT**FRONT RIGHT STABILIZER  
JACK ASSEMBLY****PARTS  
GROUP 70  
FIGURE 07  
PAGE 02**

ITEM NO.	REED'S PARTS NO.	DESCRIPTION					QTY
		1	2	3	4	5	
-1	C-3K5	Assembly, Front Right Stabilizer Jack (See Group 70, Figure 01 for NHA)					Ref
2	C-3K509	• Piece, End Stroke					1
3	C-VG121.081010	• Screw					2
4	C-3K512	• Piston					1
5	C-BS23629531	• Gasket, Seal					1
6	C-AO120.242	• Gasket, Seal					1
7	C-3K507	• Rod					1
8	C-3K502	• Cylinder					1
9	C-AO120.364	• Gasket, Seal					1
10	C-AP110.364	• Gasket, Seal					1
11	C-AG123.140	• Ring, Slide Rod					2
12	C-3K501	• Head, Slide Rod					1
13	C-BT110.140	• Gasket, Seal					1
14	C-BR310.140	• Gasket, Seal					1
15	C-UE110.20	• Washer, Elastic					2
16	C-4K518	• Screw, Foot					2
17	C-3K519	• Foot					1

DASH (-) ITEM NOT ILLUSTRATED

REVISION:

**REED**

CONCRETE PLACING  
EQUIPMENT

**FRONT LEFT AND REAR  
STABILIZER JACKS ASSEMBLY**

**PARTS  
GROUP 70  
FIGURE 08  
PAGE 01**

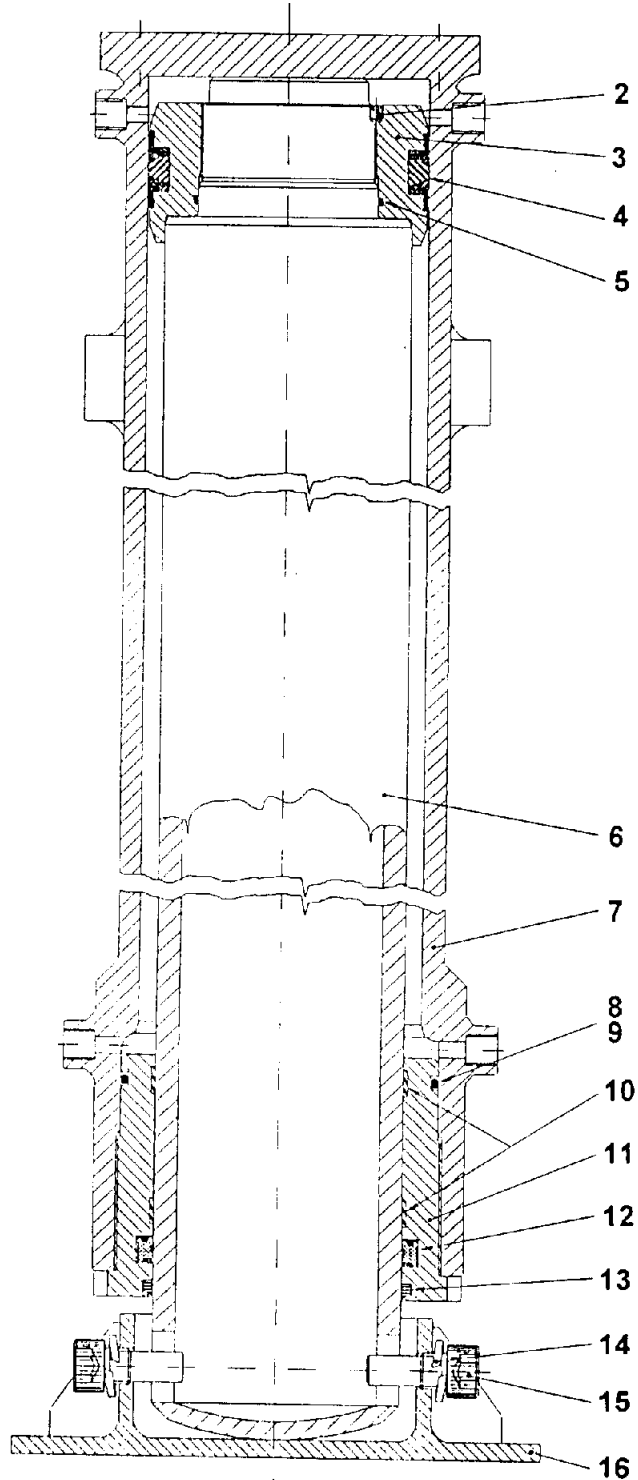
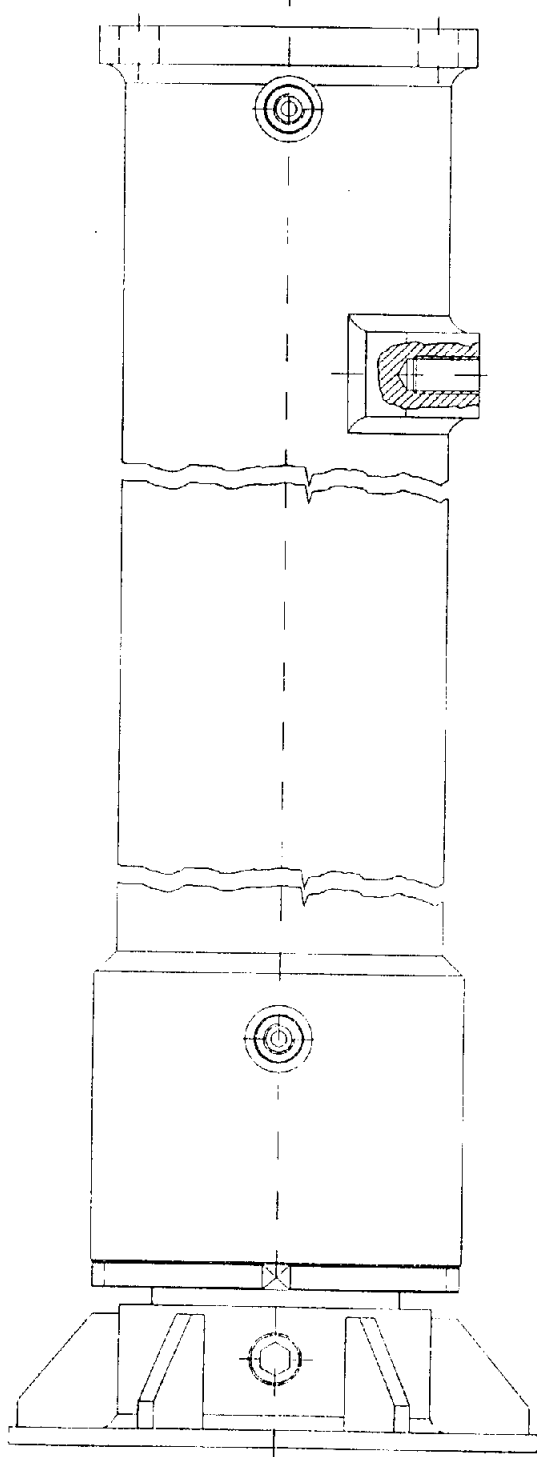
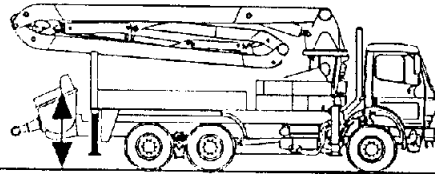
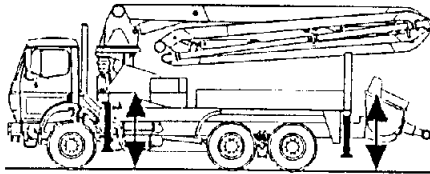

REVISION:

**REED**CONCRETE PLACING  
EQUIPMENT**FRONT LEFT AND REAR  
STABILIZER JACKS ASSEMBLY****PARTS  
GROUP 70  
FIGURE 08  
PAGE 02**

ITEM NO.	REED'S PARTS NO.	DESCRIPTION	QTY
		1 2 3 4 5	
-1	C-3L5	Assembly, Front Left And Rear Stabilizer Jacks (See Group 70, Figure 01 for NHA)	Ref
2	C-VG121.081010	• Screw	1
3	C-3K512	• Piston	1
4	C-BS23629531	• Gasket, Seal	1
5	C-AO102.242	• Gasket, Seal	1
6	C-3L507	• Rod	1
7	C-3L502A	• Cylinder	1
8	C-AO120.364	• Gasket, Seal	1
9	C-AP110.364	• Gasket, Seal	1
10	C-AG123.140	• Ring, Slide Rod	2
11	C-3K501	• Head, Slide Rod	1
12	C-BT110.140	• Gasket, Seal	1
13	C-BR310.140	• Gasket, Seal	1
14	C-UE110.20	• Washer, Elastic	2
15	C-4K518	• Screw, Foot	2
16	C-3K519	• Foot	1

DASH (-) ITEM NOT ILLUSTRATED

REVISION:

**REED**

CONCRETE PLACING  
EQUIPMENT

**REAR STABILIZERS  
HORIZONTAL JACKS ASSEMBLY**

**PARTS  
GROUP 70  
FIGURE 09  
PAGE 01**

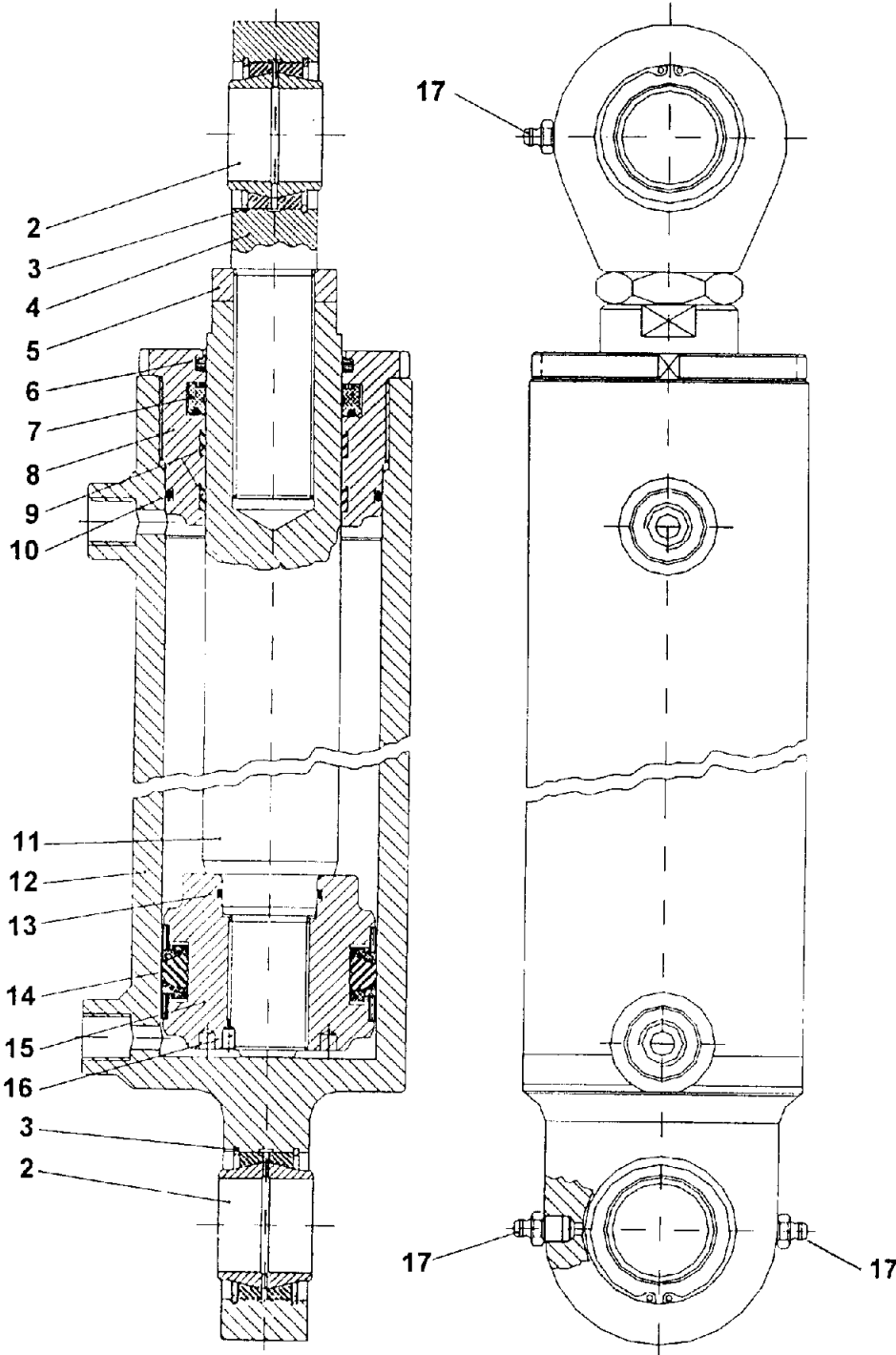
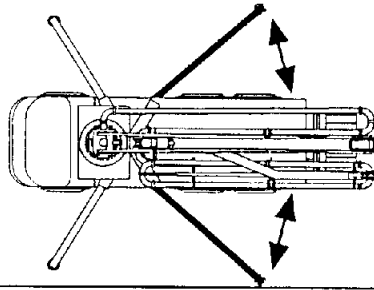

REVISION:

**REED**CONCRETE PLACING  
EQUIPMENT**REAR STABILIZERS  
HORIZONTAL JACKS ASSEMBLY****PARTS  
GROUP 70  
FIGURE 09  
PAGE 02**

ITEM NO.	REED'S PARTS NO.	DESCRIPTION	QTY
		1 2 3 4 5	
-1	C-3M3	Assembly, Rear Stabilizers Horizontal Jacks (See Group 70, Figure 01 for NHA)	Ref
2	C-CT223.035	• Joint, Ball	2
3	C-AA100.055	• Ring, Clamping	4
4	C-3M308	• Cap, Rod	1
5	C-3M325	• Nut	1
6	C-BR210.196228	• Gasket, Seal	1
7	C-BT110.050	• Gasket, Seal	1
8	C-3M301	• Head, Slide Rod	1
9	C-AG122.050	• Ring, Slide Rod	2
10	C-AO420.4287	• Ring, Sealing	1
11	C-3M307A	• Rod	1
12	C-3M302A	• Cylinder	1
13	C-AO120.126	• Ring, Sealing	1
14	C-BS23314236	• Gasket, Seal	1
15	C-1K312	• Piston	1
16	C-VG121.060008	• Screw	1
17	C-VI110.1010	• Nipple, Grease	3

DASH (-) ITEM NOT ILLUSTRATED

REVISION:

THIS PAGE INTENTIONALLY LEFT BLANK.

**GROUP 80 OPTIONAL INSTALLATION CONTAINS THE FOLLOWING FIGURES:**

- FIGURE 00** TABLE OF CONTENTS  
**FIGURE 01** HOPPER VIBRATOR ASSEMBLY  
**FIGURE 02** LUBRICATION PUMP ASSEMBLY

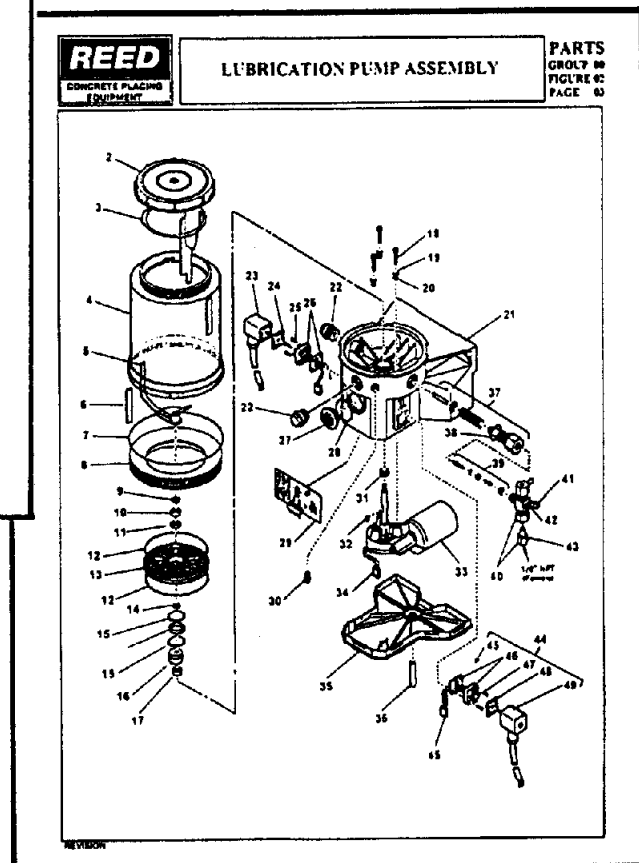
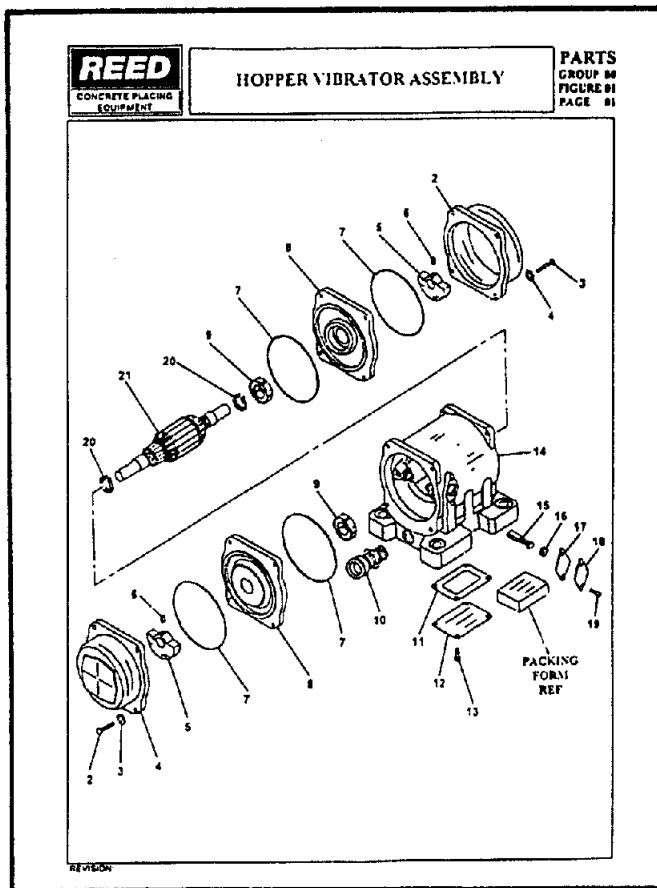

**REED**

CONCRETE PLACING  
EQUIPMENT

# HOPPER VIBRATOR ASSEMBLY

**PARTS**

**GROUP 80**

**FIGURE 01**

**PAGE 01**

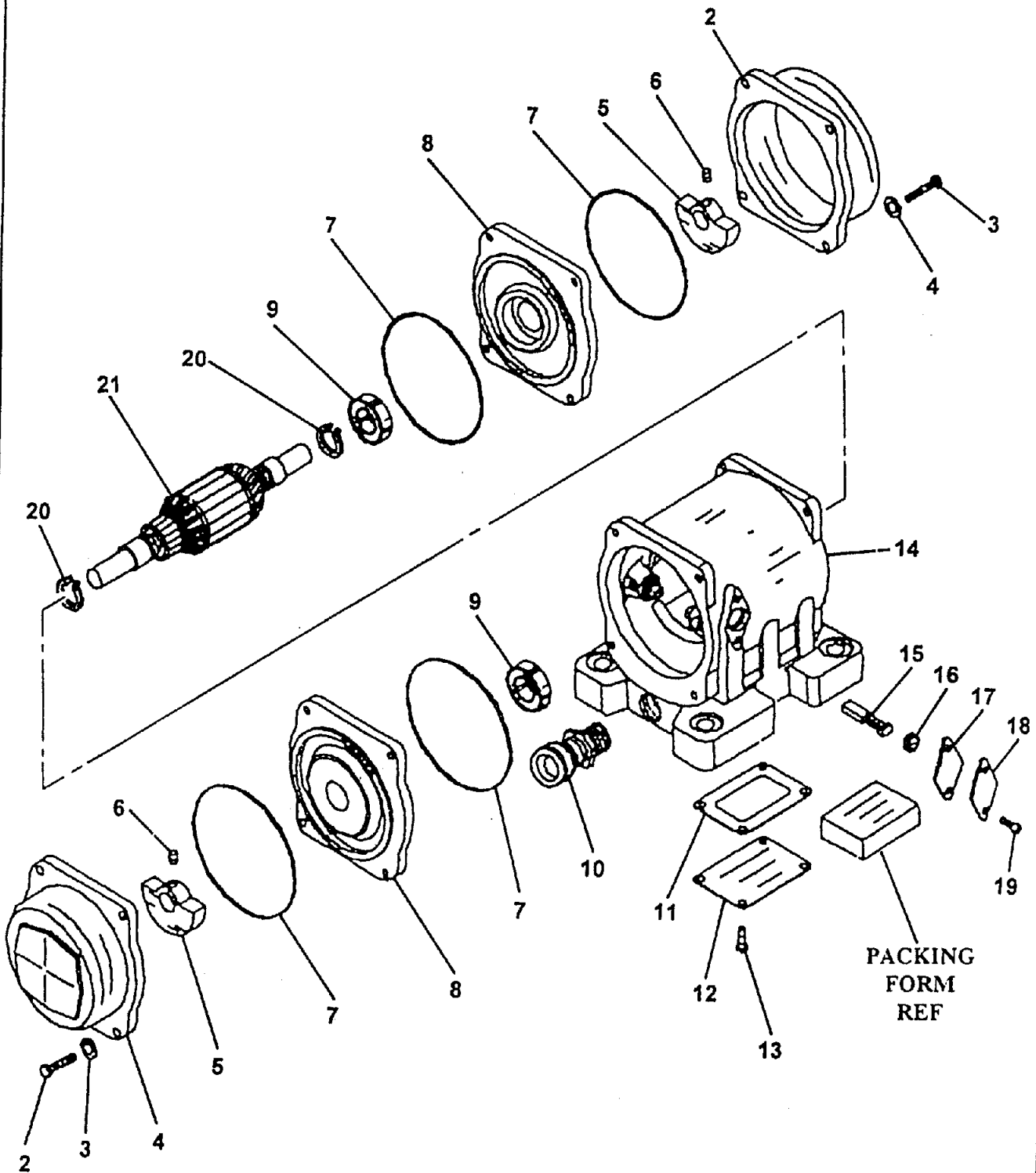

REVISION:



**REED**CONCRETE PLACING  
EQUIPMENT**HOPPER VIBRATOR ASSEMBLY****PARTS**  
GROUP 80  
FIGURE 01  
PAGE 02

ITEM NO.	REED'S PARTS NO.	DESCRIPTION	QTY
		1 2 3 4 5	
-1	71429	Assembly, Hopper Vibrator (See Group 20, Figure 01 for NHA)	Ref
2		• Cap, End	2
3		• Bolt (attaching parts)	8
4		• Washer, Lock (attaching parts)	8
5		• Weight	2
6		• Screw, Set (attaching parts)	2
7		• O-Ring	4
8		• Bell, End	2
9		• Bearing	2
10		• Holder, Cord	1
11		• Gasket	1
12		• Cover, Box	1
13		• Screw (attaching parts)	4
14		• Sub-Assembly, Housing	1
15		• Brush	1
16		• Cap, Brush	2
17		• Gasket	2
18		• Cover, Brush	2
19		• Screw (attaching parts)	4
20		• Ring, Snap	2
21		• Assembly, Armature	1

DASH (-) ITEM NOT ILLUSTRATED

REVISION:

# LUBRICATION PUMP ASSEMBLY

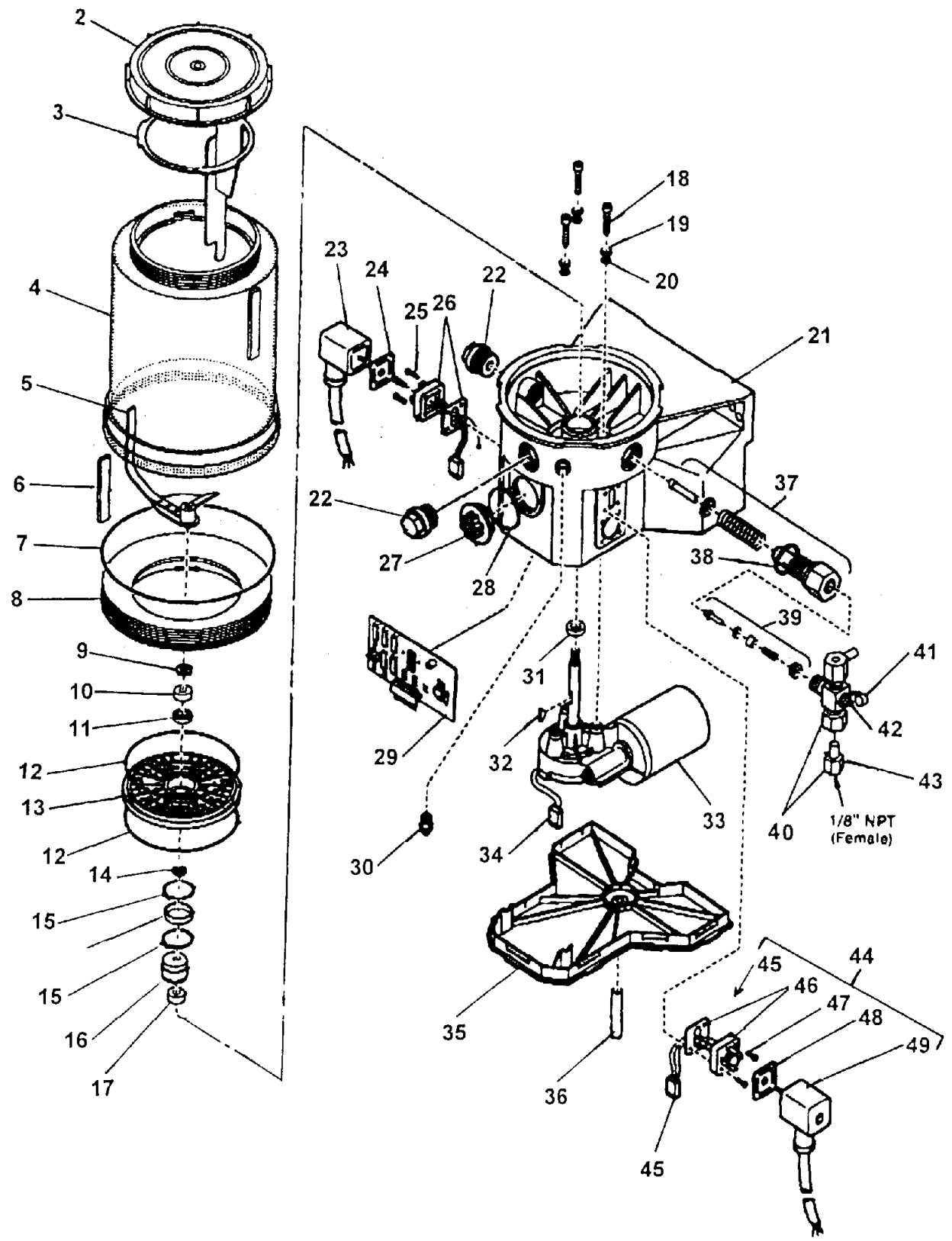

**LUBRICATION PUMP ASSEMBLY**

ITEM NO.	REED'S PARTS NO.	DESCRIPTION					QTY
		1	2	3	4	5	
-1	800065	Assembly, Lubrication Pump <i>also used 800084</i> (See Group 60, Figure 08 for NHA) <i>manual lub pump</i>					Ref
2		• Lid					1
3		• Paddle, Fixed					1
4		• Reservoir					1
5		• Paddle, Stirring					1
6		• Hose					1
7		• O-Ring					1
8		• Adapter					1
9		• Washer					1
10		• Ring, Bearing					2
11		• Bearing					1
12		• O-Ring					2
13		• Plate, Intermediate					1
14		• Shim					1
15		• Ring, Snap					2
16		• Ring, Inner					1
17		• Cam, Eccentric					1
18		• Screw					3
19		• Washer					3
20		• O-Ring					3
21		• Housing, Pump					1
22		• Plug, Closure					2
23		• Socket with Cord					1
24		• Packing, Flat					1
25		• Screw					4
26		• Plug					1
27		• Plug, Sealing					1
28		• O-Ring					1
29		• Board, Printed Circuit					1
30		• Fitting, Grease					1
31		• Seal, Radial					1
32		• Key, Wood Ruff					1
33		• Motor, 12VDC					1
34		• Plug, Motor					1
35		• Cover, Housing					1

DASH (-) ITEM NOT ILLUSTRATED

# REED

CONCRETE PLACING  
EQUIPMENT

## LUBRICATION PUMP ASSEMBLY

PARTS  
GROUP 80  
FIGURE 02  
PAGE 03

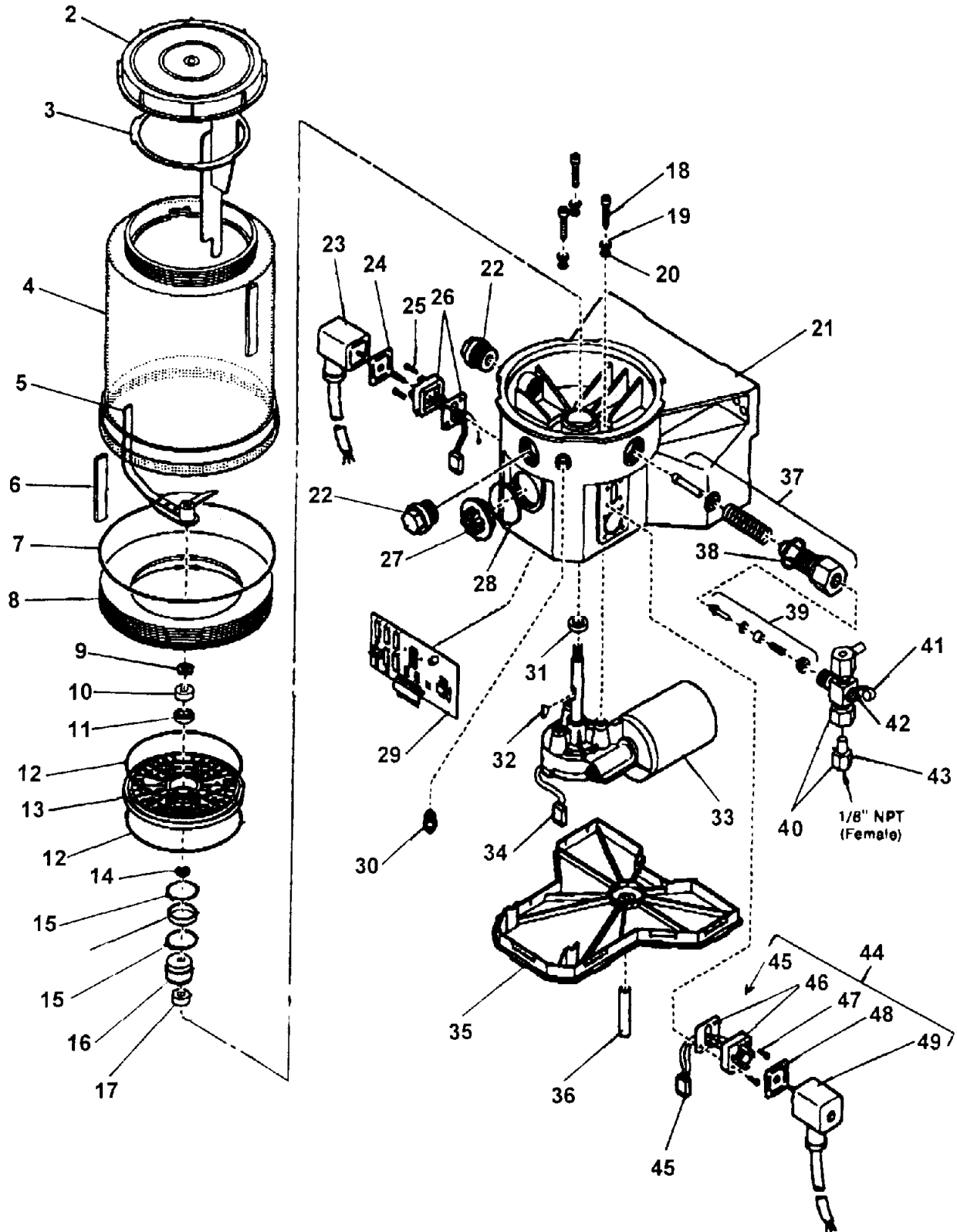

REVISION:

**LUBRICATION PUMP ASSEMBLY**

ITEM NO.	REED'S PARTS NO.	DESCRIPTION					QTY
		1	2	3	4	5	
36		• Hose					1
37		• Element, Pump					1
38		• Gasket					1
39		• Valve, Check					1
40		• Assembly, Pressure Release					1
41		• Cap, Grease					1
42		• Fitting, Grease					1
43		• Adapter for Relief					1
44		• Assembly, Optional Pressure Relief Valve					1
45		• • Cord, Optional Power					1
46		• • Plug, Optional					1
47		• • Screw, Optional					4
48		• • Packing, Optional Flat					1
49		• • Socket, Optional					1

DASH (-) ITEM NOT ILLUSTRATED

**REED**

CONCRETE PLACING  
EQUIPMENT

**PARTS MANUAL**

**PARTS**  
GROUP 80  
FIGURE 03  
PAGE 01

THIS PAGE INTENTIONALLY LEFT BLANK.

REVISION:

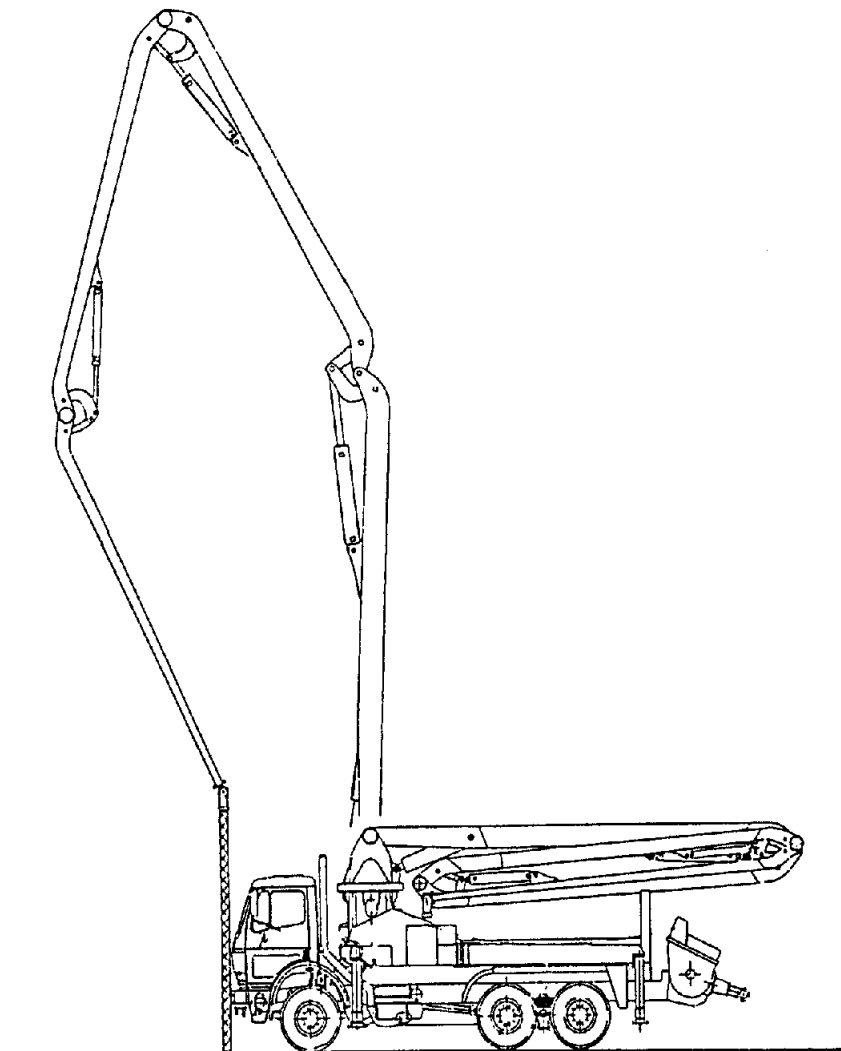

**GROUP 90 BOOM INSTALLATION CONTAINS THE FOLLOWING FIGURES:**

<b>FIGURE 00</b>	<b>TABLE OF CONTENTS</b>
<b>FIGURE 01</b>	<b>BOOM INSTALLATION</b>
<b>FIGURE 02</b>	<b>FIRST BOOM ASSEMBLY</b>
<b>FIGURE 03</b>	<b>SECOND BOOM ASSEMBLY</b>
<b>FIGURE 04</b>	<b>THIRD BOOM ASSEMBLY</b>
<b>FIGURE 05</b>	<b>FOURTH BOOM ASSEMBLY</b>
<b>FIGURE 06</b>	<b>FIRST BOOM PISTON ASSEMBLY</b>
<b>FIGURE 07</b>	<b>SECOND BOOM PISTON ASSEMBLY</b>
<b>FIGURE 08</b>	<b>THIRD BOOM PISTON ASSEMBLY</b>
<b>FIGURE 09</b>	<b>FOURTH BOOM PISTON ASSEMBLY</b>
<b>FIGURE 10</b>	<b>CONCRETE PIPELINE ASSEMBLY</b>

**REED**

CONCRETE PLACING  
EQUIPMENT

# BOOM INSTALLATION

PARTS  
GROUP 90  
FIGURE 01  
PAGE 01

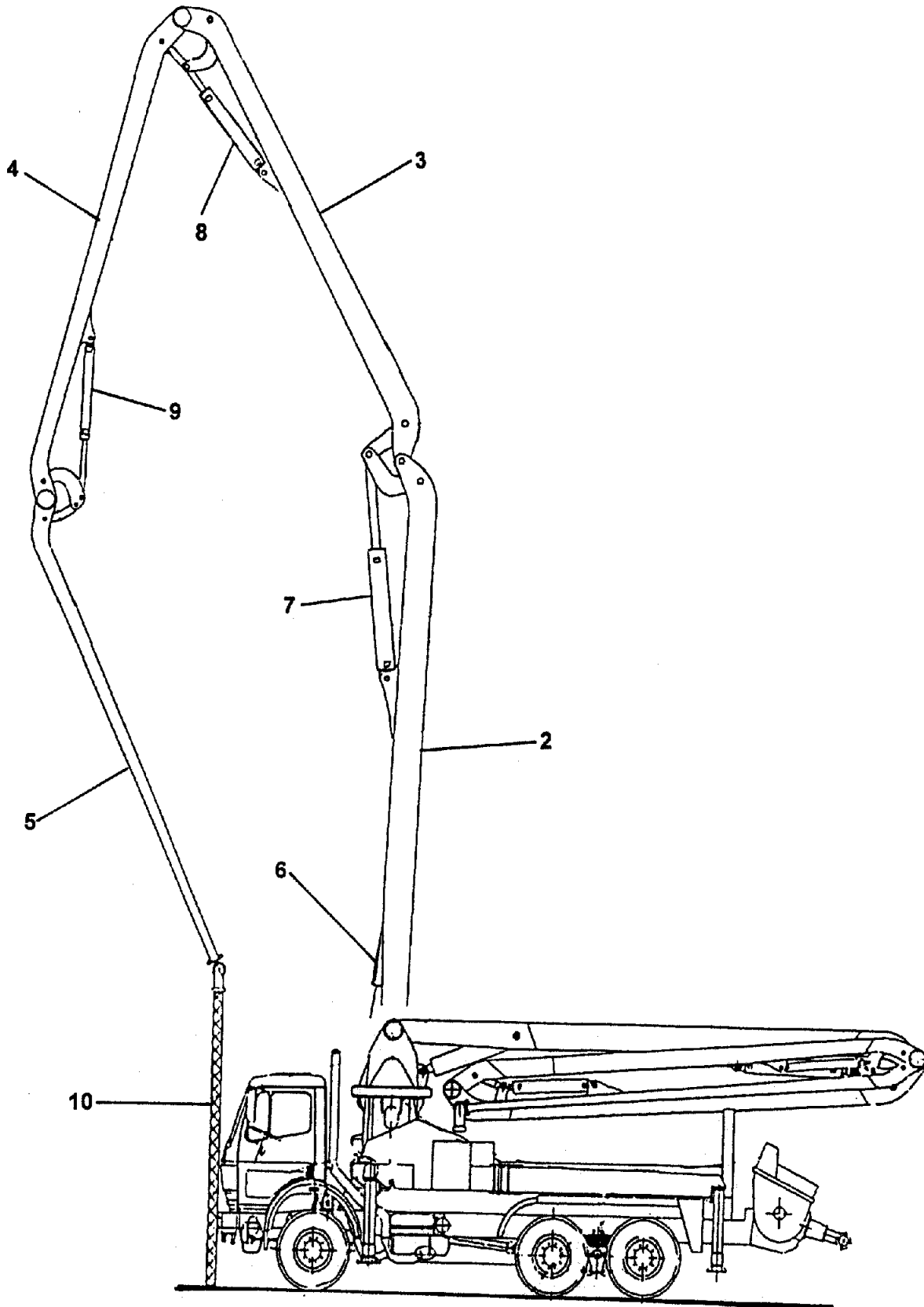

REVISION:



**REED**CONCRETE PLACING  
EQUIPMENT**BOOM INSTALLATION****PARTS****GROUP 90****FIGURE 01****PAGE 02**

ITEM NO.	REED'S PARTS NO.	DESCRIPTION	QTY
		1 2 3 4 5	
-1	90-01	Installation, Frame And Support (See Group 10, Figure 01 for NHA)	Ref
2	C-3A1	• Assembly, First Boom (See Group 90, Figure 02 for DET)	1
3	C-3A2	• Assembly, Second Boom (See Group 90, Figure 03 for DET)	1
4	C-3A3	• Assembly, Third Boom (See Group 90, Figure 04 for DET)	1
5	C-3A4	• Assembly, Fourth Boom (See Group 90, Figure 05 for DET)	1
6	C-3B1	• Assembly, First Boom Piston (See Group 90, Figure 06 for DET)	1
7	C-3B2	• Assembly, Second Boom Piston (See Group 90, Figure 07 for DET)	1
8	C-3B3	• Assembly, Third Boom Piston (See Group 90, Figure 08 for DET)	1
9	C-3B4	• Assembly, Fourth Boom Piston (See Group 90, Figure 09 for DET)	1
10	C-3T	• Assembly, Concrete Pipe Line (See Group 90, Figure 10 for DET)	1

DASH (-) ITEM NOT ILLUSTRATED

REVISION:

**FIRST BOOM ASSEMBLY**

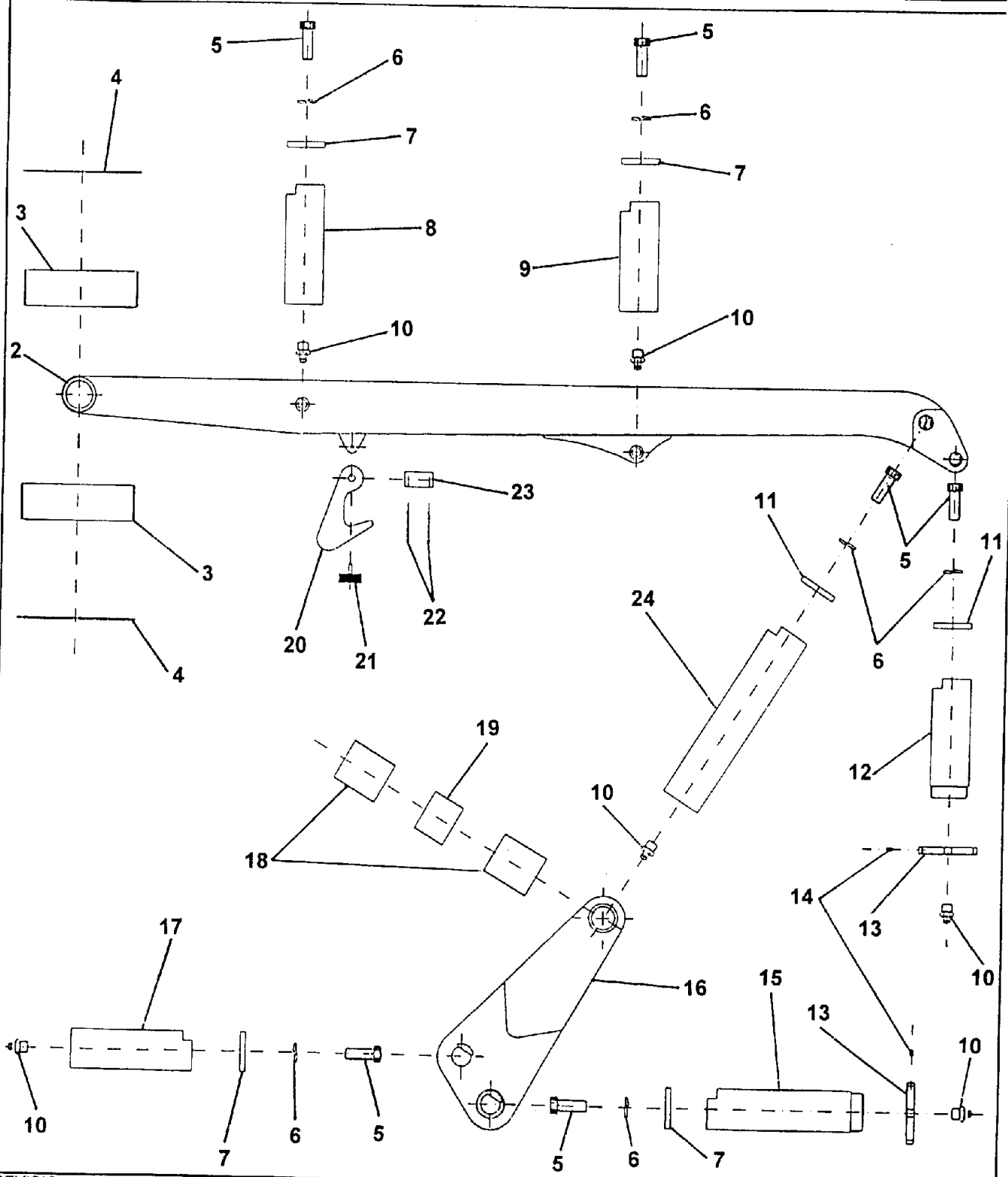
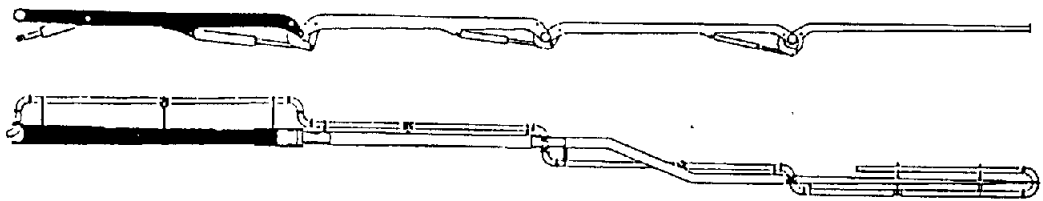

REVISION:



# FIRST BOOM ASSEMBLY

**PARTS**  
**GROUP 90**  
**FIGURE 02**  
**PAGE 02**

ITEM NO.	REED'S PARTS NO.	DESCRIPTION	QTY
		1 2 3 4 5	
-1	C-3A1	Assembly, First Boom (See Group 90, Figure 01 for NHA)	Ref
2	C-3A101	• Structure, Base	1
3	C-CD230.235070	• Bearing, Anti-friction - 802051	2
4	C-CR230.02	• Ring, Wear	2
5	C-VC111.101525	• Screw	5
6	C-UE110.10	• Washer, Elastic	5
7	C-UD080.1111	• Washer, Pin Locking	4
8	C-3P115	• Pin	1
9	C-3P114	• Pin	1
10	C-VI110.1010	• Nipple, Grease	7
11	C-UD090.1111	• Washer, Pin Locking	3
12	C-3P113	• Pin 802025	2
13	C-GV075.2015	• Ring, Thread - 802040	3
14	C-VG121.061010	• Screw	6
15	C-3P110	• Pin	1
16	C-3C101	• Beam	1
17	C-3P112	• Pin	1
18	C-CD090.095060	• Bearing, Anti-friction	2
19	C-3C102	• Piece, Distance	1
20	C-4A103	• Hook # 802068	1
21	C-UG220.10012	• Pad, Rubber	1
22	C-VS010.04050	• Pin, Split	2
23	C-4P120	• Pin	1
24	C-3P111	• Pin	1
-25	C-LG040.040	• Distance Piece, Locking	6

DASH (-) ITEM NOT ILLUSTRATED

# SECOND BOOM ASSEMBLY

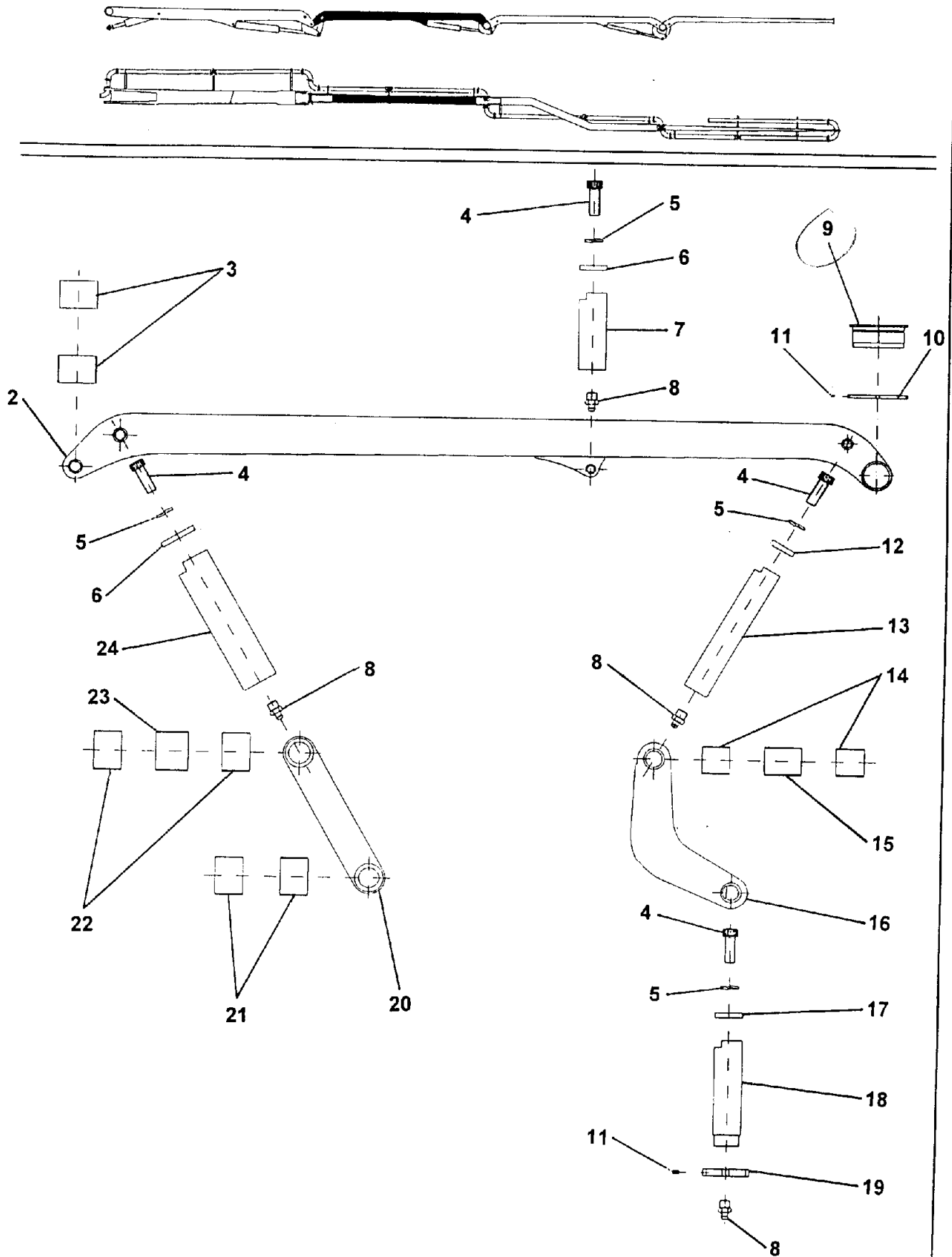

REVISION:

**REED**CONCRETE PLACING  
EQUIPMENT**SECOND BOOM ASSEMBLY****PARTS**

GROUP 90

FIGURE 03

PAGE 02

ITEM NO.	REED'S PARTS NO.	DESCRIPTION					QTY
		1	2	3	4	5	
-1	C-3A2	Assembly, Second Boom (See Group 90, Figure 01 for NHA)					Ref
2	C-3A201	• Structure, Base					1
3	C-CD090.095060	• Bearing, Anti-friction - 802055					2
4	C-VC111.101525	• Screw					4
5	C-UE110.10	• Washer, Elastic					4
6	C-UD080.1111	• Washer, Pin Locking					2
7	C-3P108	• Pin					1
8	C-VI110.1010	• Nipple, Grease					4
9	C-3P107	• Pin - ** - 1 1/2"					1
10	C-GV218.2015	• Ring, Thread					2
11	C-VG121.061010	• Screw					6
12	C-UD065.1111	• Washer, Pin Locking					1
13	C-3P106	• Pin					1
14	C-CD070.075050	• Bearing, Anti-friction					2
15	C-3C202	• Piece, Distance					1
16	C-3C201	• Beam					1
17	C-UD060.1111	• Washer, Pin Locking					1
18	C-3P105	• Pin					1
19	C-GV055.1515	• Ring, Thread					1
20	C-3D101	• Rod, Connecting					1
21	C-CD080.085060	• Bearing, Anti-friction					2
22	C-CD085.090060	• Bearing, Anti-friction					2
23	C-3D102	• Piece, Distance					1
24	C-3P109	• Pin					1
-25	C-LG040.040	• Distance Piece, Locking					6

DASH (-) ITEM NOT ILLUSTRATED

REVISION:

# REED

CONCRETE PLACING  
EQUIPMENT

## THIRD BOOM ASSEMBLY

PARTS  
GROUP 90  
FIGURE 04  
PAGE 01

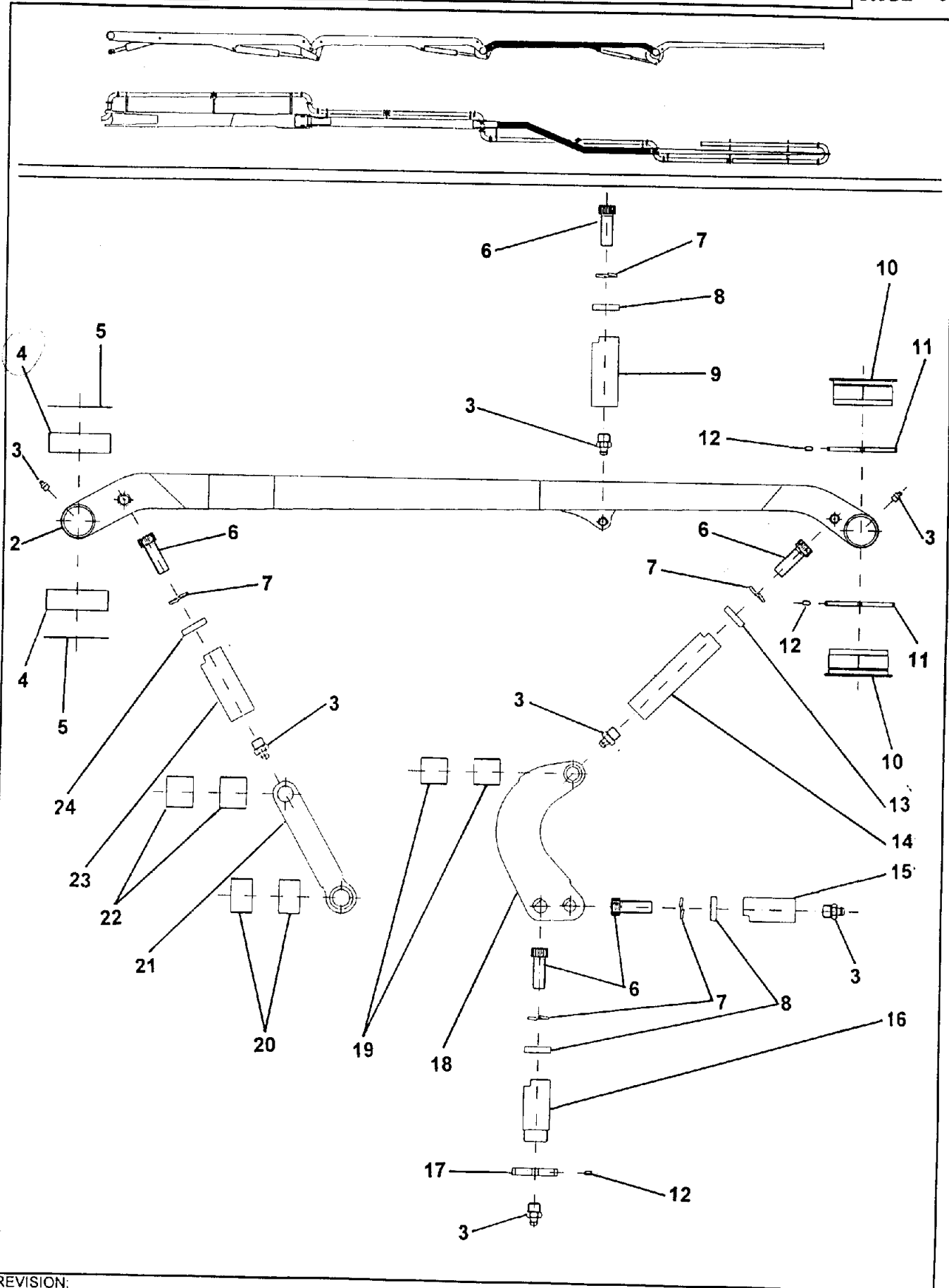

REVISION:

**REED**CONCRETE PLACING  
EQUIPMENT**THIRD BOOM ASSEMBLY****PARTS****GROUP 90****FIGURE 04****PAGE 02**

ITEM NO.	REED'S PARTS NO.	DESCRIPTION					QTY
		1	2	3	4	5	
-1	C-3A3	Assembly, Third Boom (See Group 90, Figure 01 for NHA)					Ref
2	C-3A301	• Structure, Base					1
3	C-VI110.1010	• Nipple, Grease					9
4	C-CD220.225035	• Bearing, Anti-friction - * 220 -					2
5	C-CR220.02	• Ring, Wear - 802063 -					2
6	C-VC111.101525	• Screw					5
7	C-UE110.10	• Washer, Elastic					5
8	C-UD050.1111	• Washer, Pin Locking					3
9	C-4P106	• Pin					1
10	C-4P105	• Pin					2
11	<del>C-GV218.2015</del>	• Ring, Threaded - 802041					2
12	C-VG121.061010	• Screw					6
13	C-UD055.1111	• Washer, Pin Locking					1
14	C-4P107	• Pin					1
15	C-3P102	• Pin - 802037 B660102-B66085					1
16	C-3P103	• Pin B-660103					1
17	C-GV045.1512	• Ring, Threaded - 802044					1
18	C-3C301	• Beam					1
19	C-CD055.060060	• Bearing, Anti-friction - 802061					2
20	C-CD060.065040	• Bearing, Anti-friction					2
21	C-3D201	• Rod, Connecting					1
22	C-CD065.070060	• Bearing, Anti-friction					2
23	C-3P104	• Pin					1
24	C-UD065.1111	• Washer, Pin Locking					1
-25	C-LG040.040	• Distance Piece, Locking					6

DASH (-) ITEM NOT ILLUSTRATED

SHARP Ring W-107121  
For Hollow Pin

W-106  
985

REVISION:

# FOURTH BOOM ASSEMBLY

(D)

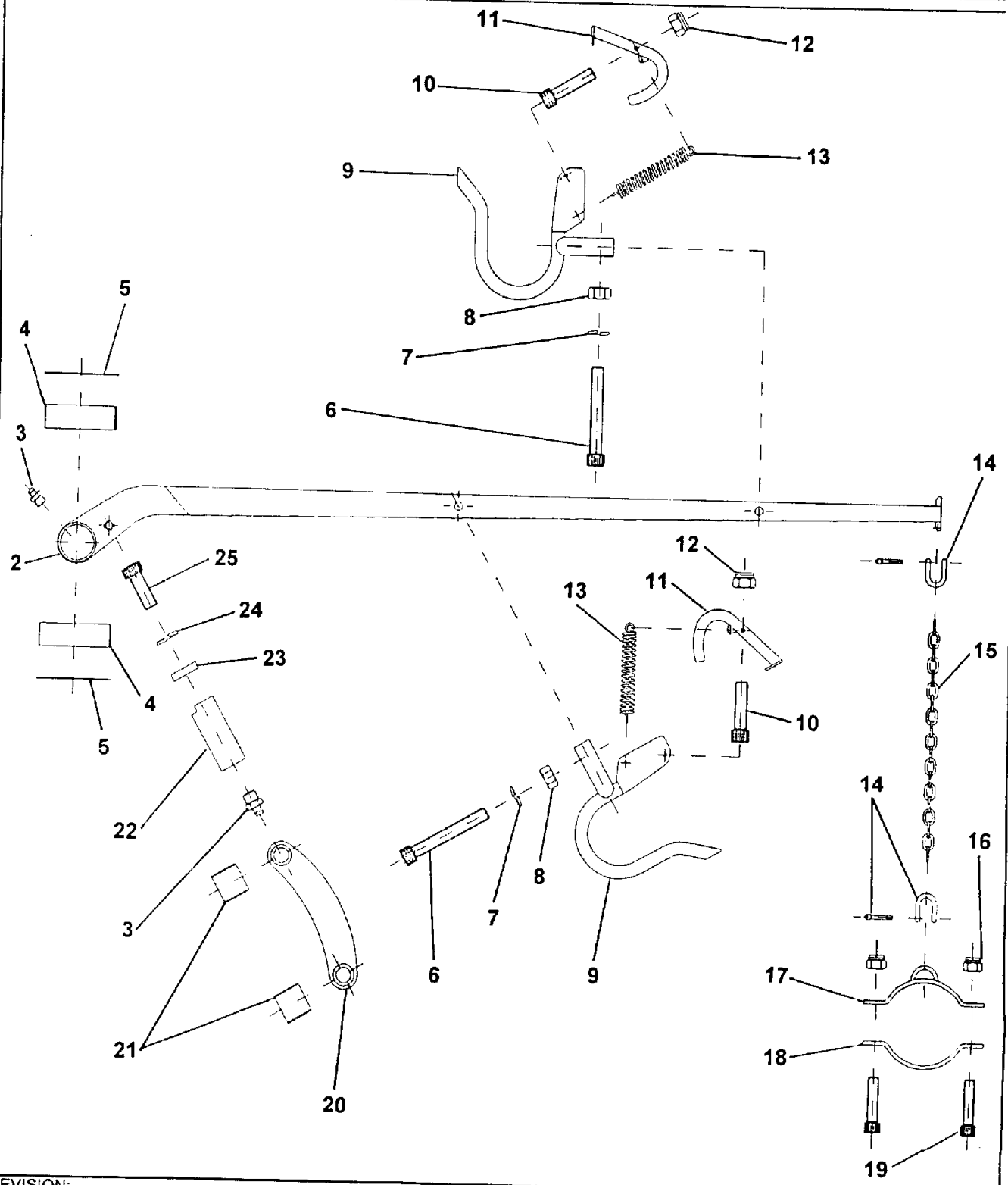
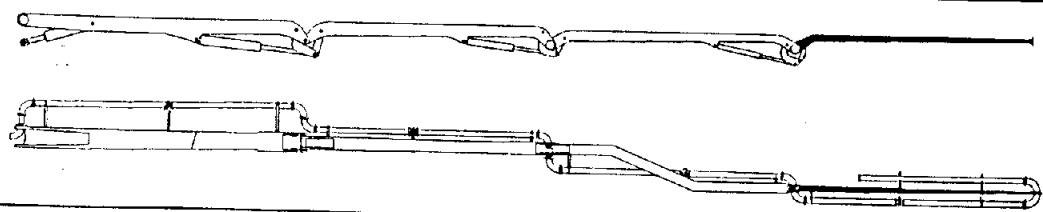

REVISION:



**REED**CONCRETE PLACING  
EQUIPMENT**FOURTH BOOM ASSEMBLY****PARTS  
GROUP 90  
FIGURE 05  
PAGE 02**

ITEM NO.	REED'S PARTS NO.	DESCRIPTION					QTY
		1	2	3	4	5	
-1	C-3A4	Assembly, Fourth Boom (See Group 90, Figure 01 for NHA)					Ref
2	C-3A401	• Structure, Base					1
3	C-VI110.1010	• Nipple, Grease					1
4	<del>C-CD220.02</del>	• Bearing, Anti-frictic					2
5	<del>C-CR220.225030</del>	• Ring, Wear <i>W-106021</i> <i>802063</i>					2
6	C-VC112.081270	• Screw					2
7	C-UE110.08	• Washer, Elastic					2
8	C-VD211.0812	• Nut					2
9	C-TS231	• Support, Flexible Hose <i>C-TS23 KIT 2 DIFF SIZE</i> <i>30 FLND 3122</i>					2
10	C-VC112.01260	• Screw					2
11	C-TS232	• Lever, Locking					2
12	C-VD212.0512	• Nut, Self Locking					2
13	C-LT020.015096	• Spring <i>RING</i>					2
14	C-AS121.008	• Plate, Shackles Die					2
15	C-AC106.0800	• Chain, Safety					1
16	C-VD212.1015	• Nut					2
17	C-TS242	• Collar, Connecting Safety					1
18	C-TS241	• Collar, Safety					1
19	C-VC112.101560	• Screw					2
20	C-3D301	• Rod, Connection					2
21	C-CD050.055050	• Bearing, Anti-friction <i>802062 OR W-106012</i>					2
22	C-3P101	• Pin					1
23	C-UD050.1111	• Washer, Pin Locking					1
24	C-UE110.10	• Washer, Elastic					1
25	C-VC111.101525	• Screw					1

DASH (-) ITEM NOT ILLUSTRATED

REVISION:

**REED**

CONCRETE PLACING  
EQUIPMENT

# FIRST BOOM PISTON ASSEMBLY

**PARTS**

GROUP 90

FIGURE 06

PAGE 01

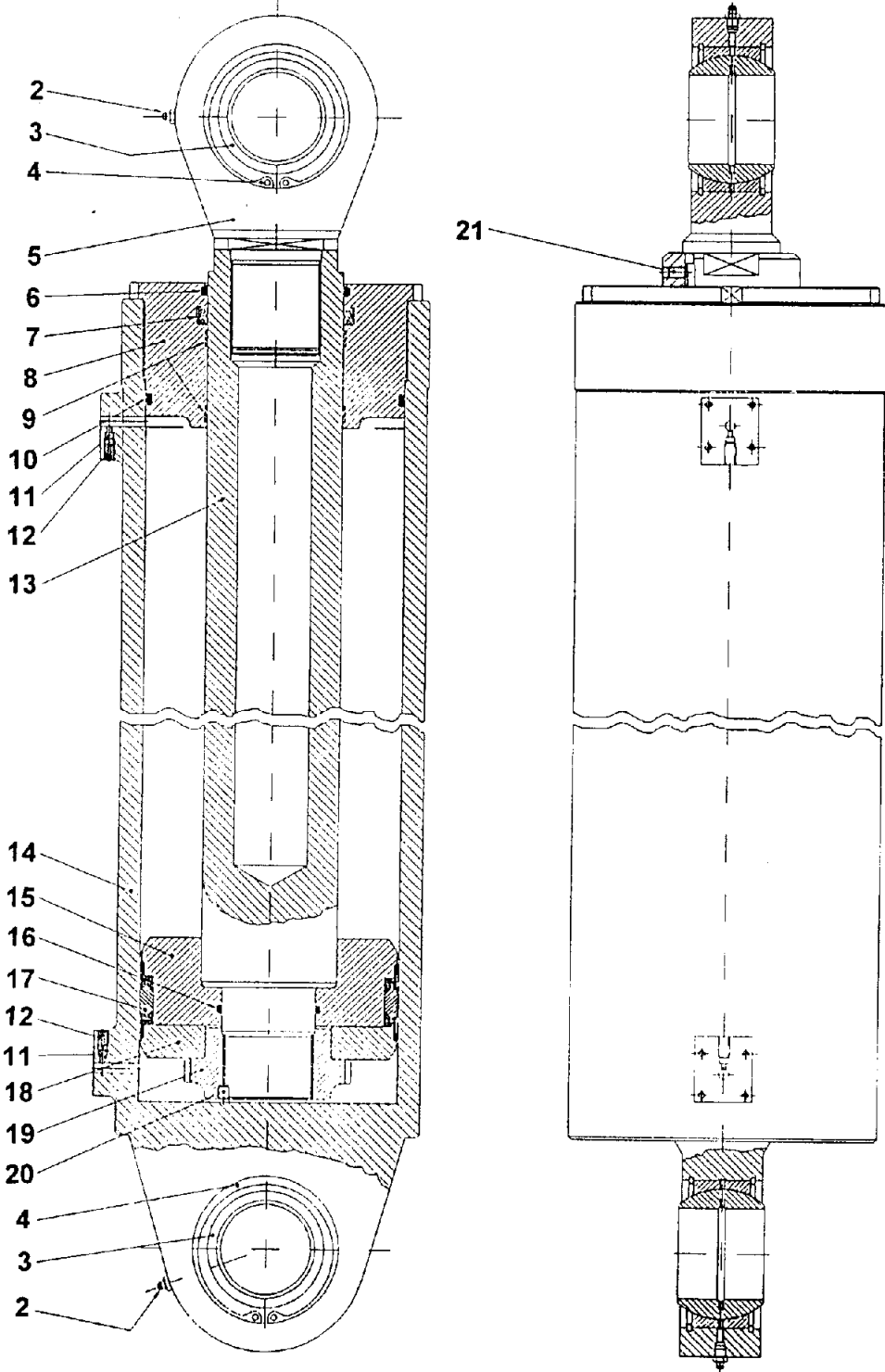
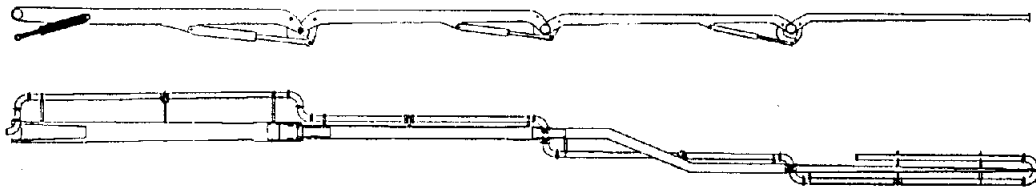

REVISION:



# FIRST BOOM PISTON ASSEMBLY

**PARTS**  
**GROUP 90**  
**FIGURE 06**  
**PAGE 02**

ITEM NO.	REED'S PARTS NO.	DESCRIPTION					QTY
		1	2	3	4	5	
-1	C-3B1	Assembly, First Boom Piston (See Group 90, Figure 01 for NHA)					Ref
2	C-VI110.1010	• Nipple, Grease					2
3	C-CT213.080	• Joint, Ball					2
4	C-AA100.130	• Ring, Clamping					4
5	C-3B108	• Cap, Rod					1
6	C-BR310.120	• Gasket, Seal					1
7	C-BT110.120	• Gasket, Seal					1
8	C-3B101	• Head, Slide Rod					1
9	C-AG123.120	• Ring, Slide Rod					2
10	C-AO120.372	• Ring, Sealing					1
11	C-CS200.007	• Ball, Still					2
12	C-WPVS1	• Valve, Air Hole					2
13	C-3B107	• Rod					1
14	C-3B102	• Cylinder					1
15	C-3B112	• Piston					1
16	C-AO420.6325	• Ring, Sealing					1
17	C-BS229058071A	• Gasket, Seal					1
18	C-3B116	• Ring, Piston					1
19	C-4B109	• Nut, Rod					1
20	C-VG121.101212	• Screw					1
21	C-VG122.101215	• Screw					
-22	C-AP110.372	• Ring, Sealing					1

DASH (-) ITEM NOT ILLUSTRATED

# SECOND BOOM PISTON ASSEMBLY

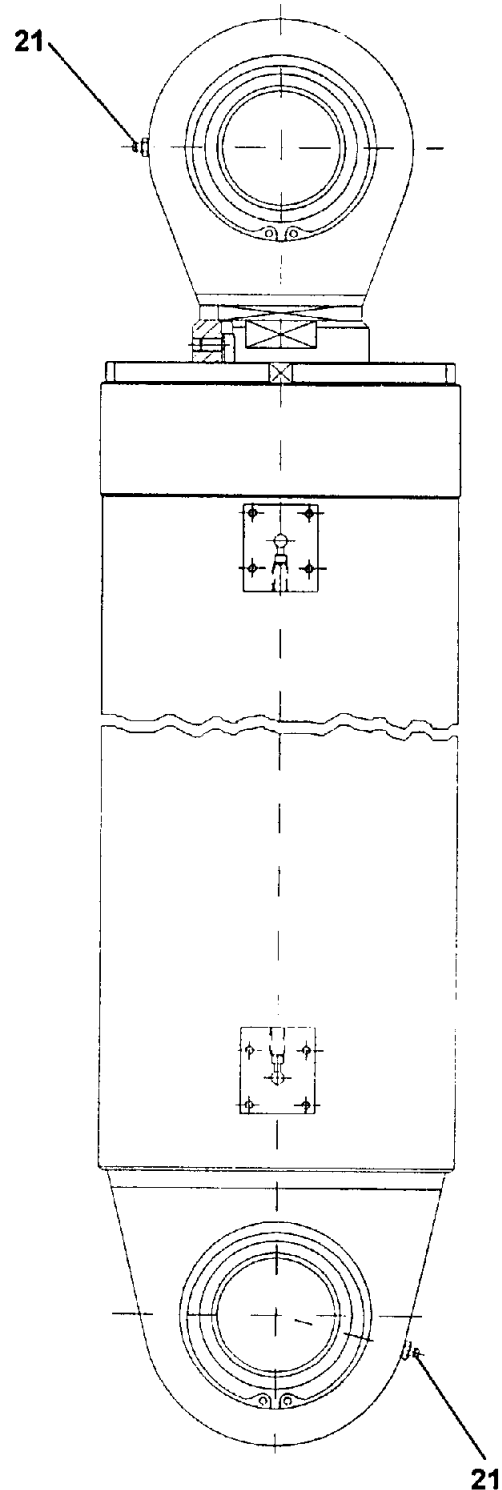
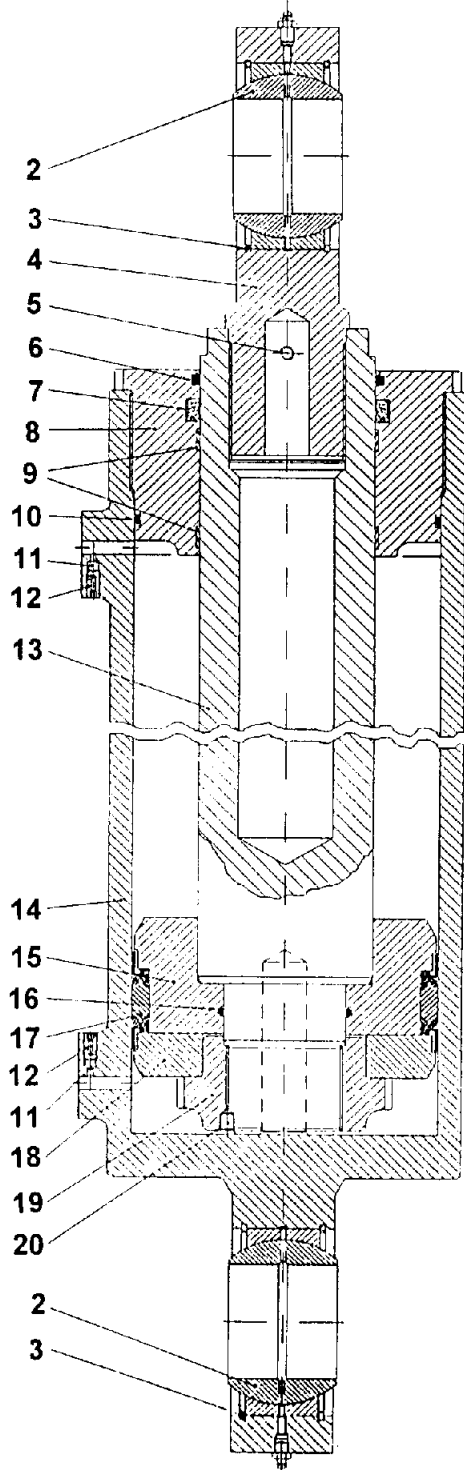
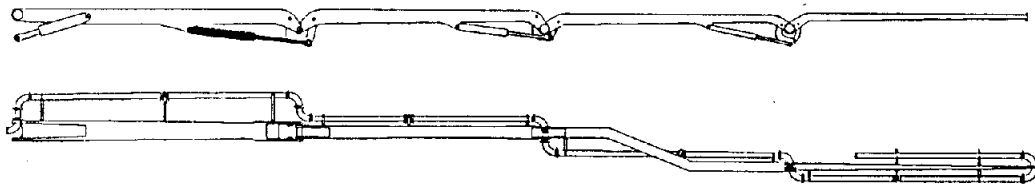

**REED**CONCRETE PLACING  
EQUIPMENT**SECOND BOOM PISTON ASSEMBLY****PARTS****GROUP 90****FIGURE 07****PAGE 02**

ITEM NO.	REED'S PARTS NO.	DESCRIPTION					QTY
		1	2	3	4	5	
-1	C-3B2	Assembly, Second Boom Piston (See Group 90, Figure 01 for NHA)					Ref
2	C-CT213.080	• Joint, Ball					2
3	C-AA100.130	• Ring, Clamping					4
4	C-4B108	• Cap, Rod					1
5	C-VG122.101215	• Screw					1
6	C-BR310.120	• Gasket, Seal					1
7	C-BT110.120	• Gasket, Seal					1
8	C-3B201	• Head, Slide Rod					1
9	C-AG123.120	• Ring, Slide Rod					2
10	C-AO120.368	• Ring, Sealing					1
11	C-CS200.007	• Ball, Steel					2
12	C-WPVS1	• Valve, Air Hole					2
13	C-3B207	• Rod					1
14	C-3B202	• Cylinder					1
15	C-3B212	• Piston					1
16	C-AO420.6325	• Ring, Sealing					1
17	C-BS228267281A	• Ring, Sealing					1
18	C-4B116	• Ring, Piston					1
19	C-4B109	• Nut, Rod					1
20	C-VG121.101212	• Screw					1
21	C-VI110.1010	• Nipple, Grease					2
-22	C-API110.368	• Gasket, Seal					1

DASH (-) ITEM NOT ILLUSTRATED

REVISION:

# THIRD BOOM PISTON ASSEMBLY

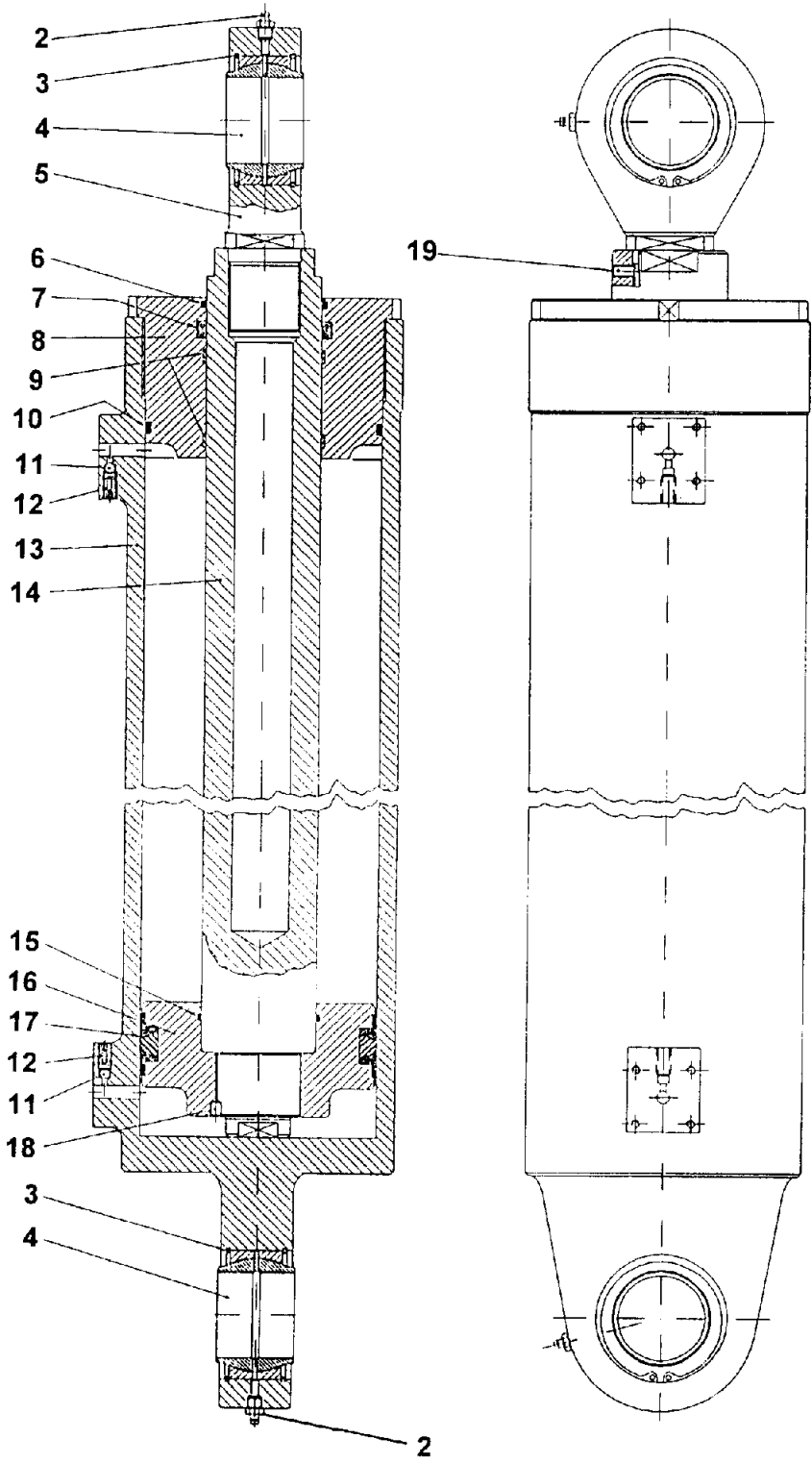
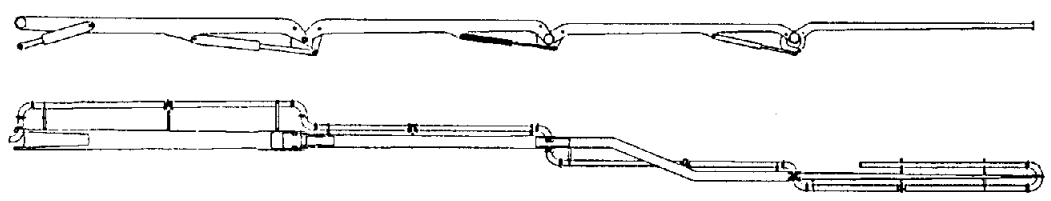

REVISION:

**THIRD BOOM PISTON ASSEMBLY**

ITEM NO.	REED'S PARTS NO.	DESCRIPTION					QTY
		1	2	3	4	5	
-1	C-3B3	Assembly, Third Boom Piston (See Group 90, Figure 01 for NHA)					Ref
2	C-VI110.1010	• Nipple, Grease					2
3	C-AA100.090	• Ring, Clamping					4
4	C-CT223.060	• Joint, Ball					2
5	C-4B408	• Cap, Rod					1
6	C-BR310.080	• Gasket, Seal					1
7	C-BT110.080	• Gasket, Seal					1
8	C-3B301	• Head, Slide Rod					1
9	C-AG122.080	• Ring, Slide Rod					2
10	C-AO120.361	• Ring, Sealing					1
11	C-CS200.007	• Ball, Steel					2
12	C-WPVS1	• Valve, Air Hole					2
13	C-3B302	• Cylinder					1
14	C-3B307	• Rod					1
15	C-AO420.4312	• Ring, Seal					1
16	C-3B312	• Piston					1
17	C-BS23649551	• Gasket, Seal					1
18	C-VG121.081010	• Screw					1
19	C-VG122.081015	• Screw					1
-20	C-AP110.361	• Gasket, Seal					1

DASH (-) ITEM NOT ILLUSTRATED





**REED**CONCRETE PLACING  
EQUIPMENT**FOURTH BOOM PISTON ASSEMBLY****PARTS**

GROUP 90

FIGURE 09

PAGE 02

ITEM NO.	REED'S PARTS NO.	DESCRIPTION					QTY
		1	2	3	4	5	
-1	C-3B4	Assembly, Fourth Boom Piston (See Group 90, Figure 01 for NHA)					Ref
2	C-AA100.075	• Ring, Clamping					4
3	C-CT223.050	• Joint, Ball					2
4	C-4B408	• Cap, Rod					4
5	C-VG122.060012	• Screw					1
6	C-BR310.070	• Gasket, Seal					1
7	C-BT110.070	• Gasket, Seal					1
8	C-3B401	• Head, Slide Rod					1
9	C-AG122.070	• Ring, Slide Rod					1
10	C-AO120.348	• Ring, Sealing					1
11	C-CS200.007	• Ball, Steel					1
12	C-WPVS1	• Valve, Air Hole					1
13	C-3B407	• Rod					1
14	C-3B402	• Cylinder					1
15	C-AO420.348	• Ring, Sealing					1
16	C-BS23472374	• Gasket, Seal					1
17	C-3B412	• Piston					1
18	C-VG121.081010	• Screw					1
19	C-VI110.1010	• Nipple, Grease					2
-20	C-API110.348	• Gasket, Seal					1

DASH (-) ITEM NOT ILLUSTRATED

REVISION:

**CONCRETE PIPE LINE ASSEMBLY**

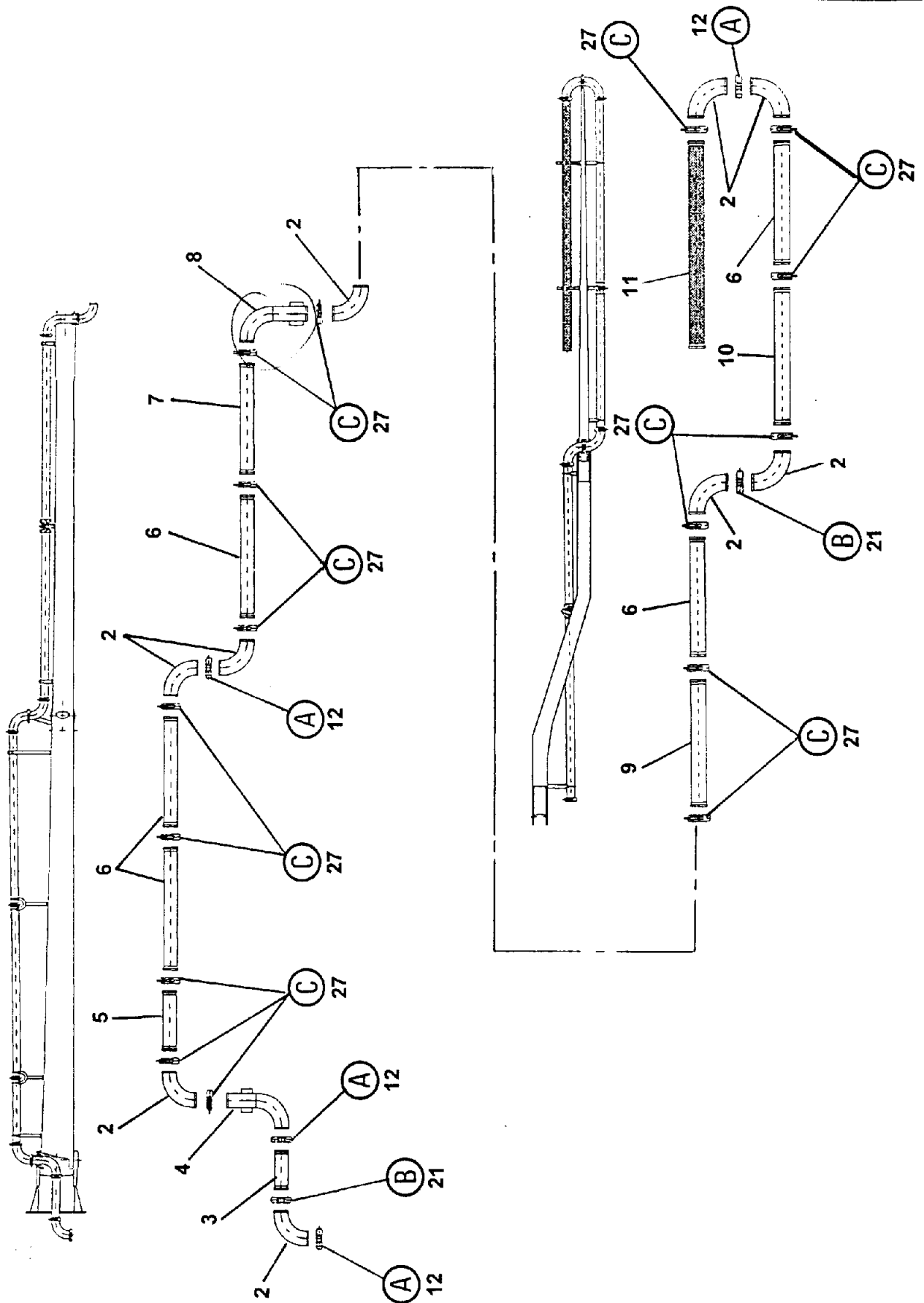

REVISION:

**REED**CONCRETE PLACING  
EQUIPMENT**CONCRETE PIPE LINE ASSEMBLY****PARTS**

GROUP 90

FIGURE 10

PAGE 02

ITEM NO.	REED'S PARTS NO.	DESCRIPTION					QTY
		1	2	3	4	5	
-1	C-3T	Assembly, Concrete Pipeline (See Group 90, Figure 01 for NHA)					Ref
2	C-TC125.1	• Bend 801100					9
3	C-TT206.70	• Pipe					1
4	C-TM204.53	• Pipe with Bend 801102					1
5	C-TT211.50	• Pipe					1
6	C-TT230.00	• Pipe					5
7	C-TT232.90	• Pipe					1
8	C-TM205.58	• Pipe with Bend 801103					1
9	C-TT232.90	• Pipe					1
10	C-TT232.90	• Pipe					1
11		• Hose, Flexible Max 4m					1
12	C-TG222	• Coupling, Bracket 2 Bolts					4
21	C-TG221	• Coupling, 2 Bolts					2
27	C-TG211	• Coupling, Lever					16

DASH (-) ITEM NOT ILLUSTRATED

REVISION:

**CONCRETE PIPE LINE ASSEMBLY**

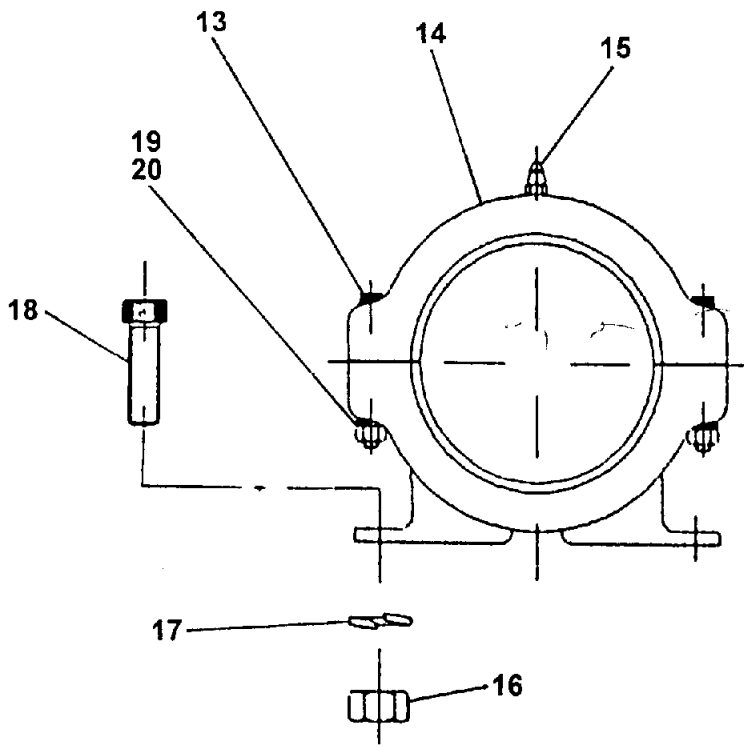

(A)

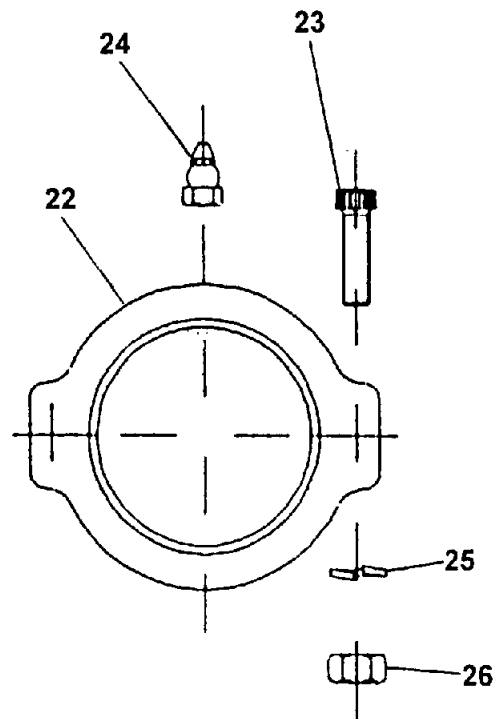

(B)

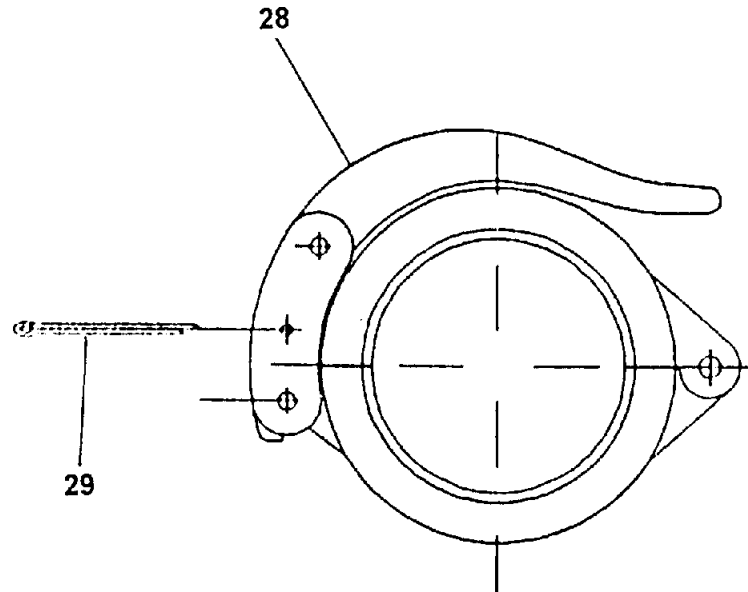

(C)

**REED**CONCRETE PLACING  
EQUIPMENT**CONCRETE PIPE LINE ASSEMBLY****PARTS****GROUP 90****FIGURE 10****PAGE 04**

ITEM NO.	REED'S PARTS NO.	DESCRIPTION	QTY
		1 2 3 4 5	
12	C-TG222	• Coupling, Bracket 2 Bolts	4
13	C-VC112.121755	• • Screw	2
14		• • Coupling	1
15	C-VI110.1010	• • Nipple, Grease	1
16	C-VD111.1420	• • Nut	2
17	C-UE110.14	• • Washer, Elastic	2
18	C-VC111.142035	• • Screw	2
19	C-UE110.12	• • Washer, Elastic	2
20	C-VD111.1217	• • Nut	2
21	C-TG221	• Coupling, 2 Bolts	2
22		• • Coupling	1
23	C-VC112.121755	• • Screw	2
24	C-VI110.1010	• • Nipple, Grease	1
25	C-UE110.12	• • Washer, Elastic	2
26	C-VD111.1217	• • Nut	2
27	C-TG211	• Coupling, Lever	16
28		• • Coupling	1
29	C-VS110.08040	• • Pin, Split	1

DASH (-) ITEM NOT ILLUSTRATED

REVISION:

**REED**

CONCRETE PLACING  
EQUIPMENT

**PARTS MANUAL**

**PARTS**  
**GROUP 90**  
**FIGURE 11**  
**PAGE 01**

THIS PAGE INTENTIONALLY LEFT BLANK.

REVISION: